

Service guide

# Solenoid valve

Types EVR 2 - EVR 22 (version 2)

032R9605

032R9605

NC solder

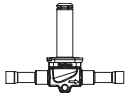

NC flare



NC flange

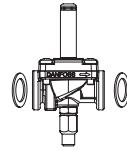

NO solder

**Note:**  
tube design

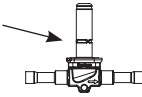

## Disassembly and assembly of 032Lxxxx only

### Mounting / dismounting of top part EVR 2 - EVR 8

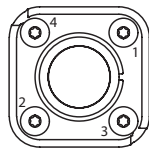
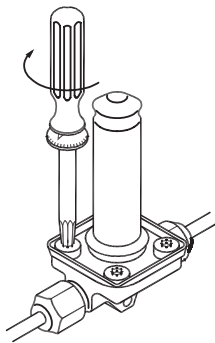

**Note!**  
Always use  
cross-tightening

Type	[Nm]	[kpm]	[ft-lbs]	Torx size
EVR 2, EVR 3, EVR 4, EVR 6, EVR 8	3.0	0.3	2.2	T15

### Mounting / dismounting of top part EVR 10 - EVR 22

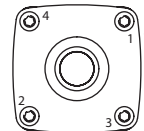
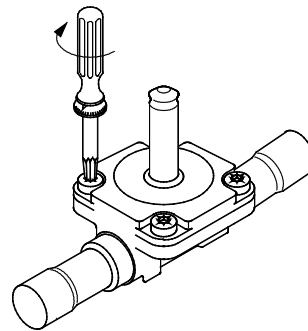

**Note!**  
Always use  
cross-tightening

Type	[Nm]	[kpm]	[ft-lbs]	Torx size
EVR 10, EVR 15, EVR 18	10	1	7.4	T30
EVR 20, EVR 22	30	3	22.1	T45

### Mounting of support washer

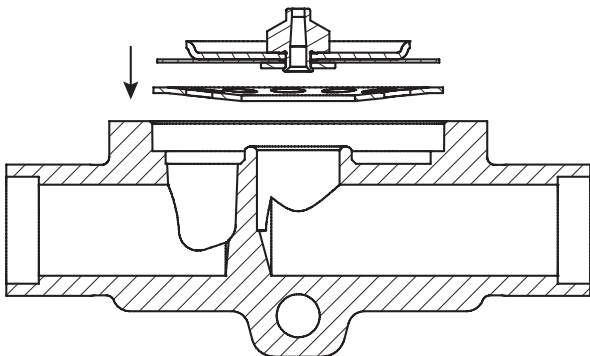

### Special for EVR 4 - EVR 8: Dismounting gasket and supporting ring

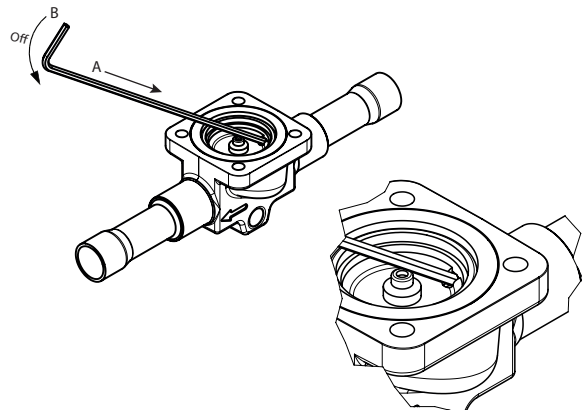

**Caution!**  
For EVR 2 - EVR 3, and EVR 10 - EVR 22, a screwdriver might be needed for removal of the gasket. Be careful not to scratch the gasket surface.

EVR 2 – EVR 3 (NC)

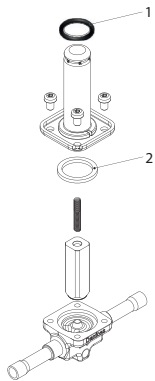

EVR 4 – EVR 8 (NC)

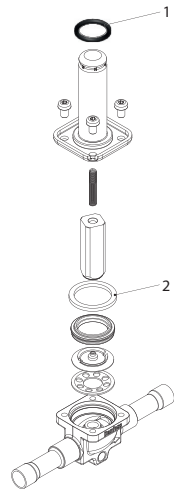

EVR 10 – EVR 22 (NC)

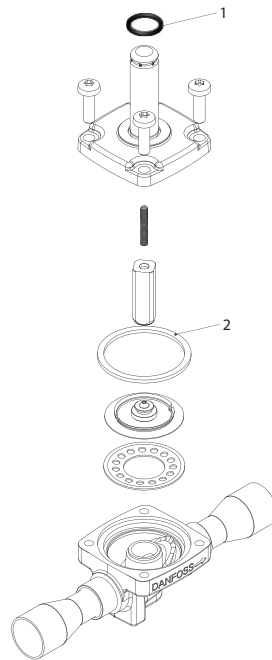

EVR 4 – EVR 8 (NO)

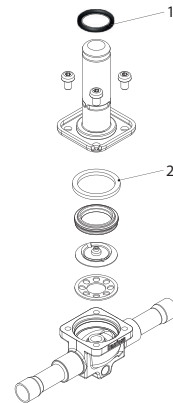

EVR 10 – EVR 20 (NO)

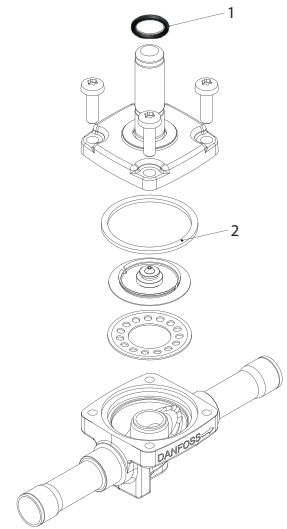

Pos. no.	Description	Dimension		Material
1	O-ring	ID 14.30 x H 2.40		Chloroprene
2	Gasket	EVR 2 - EVR 3	OD 22.2 x ID 18.0 x H 2.5	Chloroprene
		EVR 4 - EVR 8	OD 26.1 x ID 21.1 x H 2.5	Chloroprene
		EVR 10	OD 40.7 x ID 35.5 x H 2.6	Chloroprene
		EVR 15 - EVR 18	OD 48.7 x ID 43.5 x H 2.6	Chloroprene
		EVR 20 - EVR 22	OD 64.2 x ID 59.0 x H 2.6	Chloroprene