

Data sheet

Butterfly valves with gear box VFY-WG, VFY-LG

Description



Features:

- Spline driven one piece shaft connected to spherically machined disc allows high torque transmission i.e. quick response and minimum back-lash
- Long term reliability due to upper and lower anti-friction bearings
- Safe maintenance: shaft blow out protection with circlip
- Position indicator

Main Data*:

- DN 50-200
- k_{vs} 79-2500 m³/h
- PN 16
- EPDM Liner
- Stainless steel or Ductile iron Epoxy Coated disc
- Medium:
 - Circulation water or chilled glycolic water up to 50 %
- Medium Temperature:
 - 10 ... 120 °C (EP disc)
 - 10 ... 130 °C (SS disc)
- Wafer or Lug connection
- Approvals: **CE EAC**

** please check the Directive 2014/68/UE table at the end of the data sheet for appropriate product selection*

Ordering

Wafer type **VFY-WG**

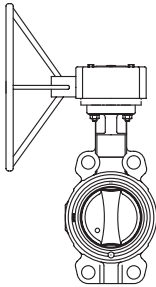
	DN	k_{vs} (m ³ /h)	PN	T _{max} (°C)	Disc	Code No.
	Stainless Steel	50	79	16	130	
65		174	065B7441			
80		275	065B7442			
100		496	065B7443			
125		883	065B7444			
150		1212	065B7445			
200		2500	065B7446			
Ductile iron Epoxy Coated	50	79	16	120		065B8420
	65	174				065B8421
	80	275				065B8422
	100	496				065B8423
	125	883				065B8424
	150	1212				065B8425
	200	2500				065B8426

Ordering

Lug type **VFY-LG**

	DN	k_{vs} (m ³ /h)	PN	T_{max} (°C)	Disc	Code No.
	50	79	16	130	Stainless Steel	065B7460
	65	174				065B7461
	80	275				065B7462
	100	496				065B7463
	125	883				065B7464
	150	1212				065B7465
	200	2500				065B7406
	50	79	16	120	Ductile iron Epoxy Coated	065B8430
	65	174				065B8431
	80	275				065B8432
	100	496				065B8433
	125	883				065B8434
	150	1212				065B8435
200	2500	065B8436				

Spare parts

Replacement Liner **VFY-W Liner**

DN	PN	Liner	Code No.
50	16	EPDM	065B7582
65			065B7583
80			065B7584
100			065B7585
125			065B7578
150			065B7579
200			065B7592

Replacement gearbox **VFY-Gearbox**

for DN	Code No.
50/65/80/100	065B7595
125/150/200	065B7596

Technical data

Type	VFY-WG		VFY-LG	
Nominal diameter	DN	50-200		
k_{vs} value	m ³ /h	79-2500		
Rotation angle	90 °			
Leakage rate	Acc. to PED 2014/68/EU, EN 12266-1, Rate A ¹⁾			
Nominal pressure	PN	16		
Medium	Circulation water, Glycolic water up to 50 %			
Medium temperature	EP disc	°C	-10 ... 120 (see p-T diagram)	
	SS disc		-10 ... 130 (see p-T diagram)	
Connection	Wafer (centering lugs)		Lug (Tapped lugs)	
Mounting	mounting between flanges		mounting deadline	
Material				
Body	Cast iron EN GJL 250 (DIN GG25) DN 50-200		Cast iron EN GJL 250 (DIN GG25) DN 50-150 Ductile iron (DIN GGG40) DN 200	
Disc	Ductile iron EN GJS 400-15 (DIN GGG 40) with Epoxy coating or Stainless Steel			
Shaft	Stainless steel AISI 420			
Liner	EPDM			
Circlip	Steel XC 75 / Stainless steel			
O-ring	Nitrile/Viton			
Upper guide bush	Zinc coated S. + PTFE			
Lower guide bush	Zinc coated S. + PTFE			
Gear box	Aluminium			

¹⁾ No visible detectable leakage during the testing procedure

Installation positions

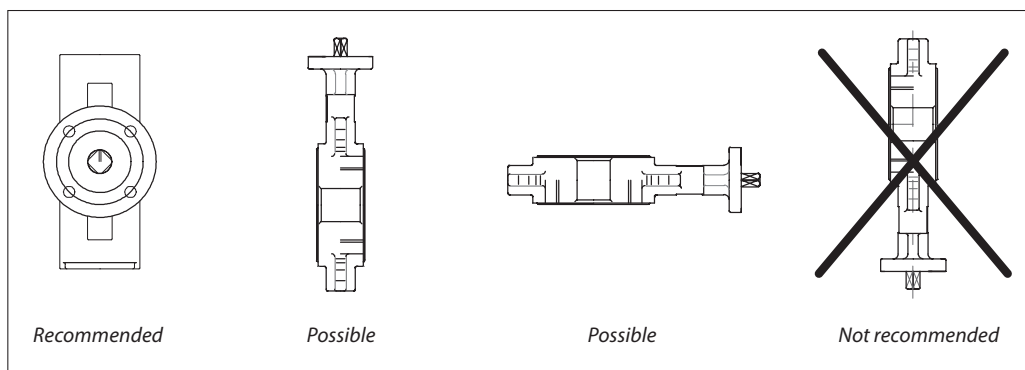

Installation conditions

It is recommended that distances indicated below are respected in order to prolong lifetime of the valve. Mounting the valve close to pipework junctions (turbulent zones) increases wear.

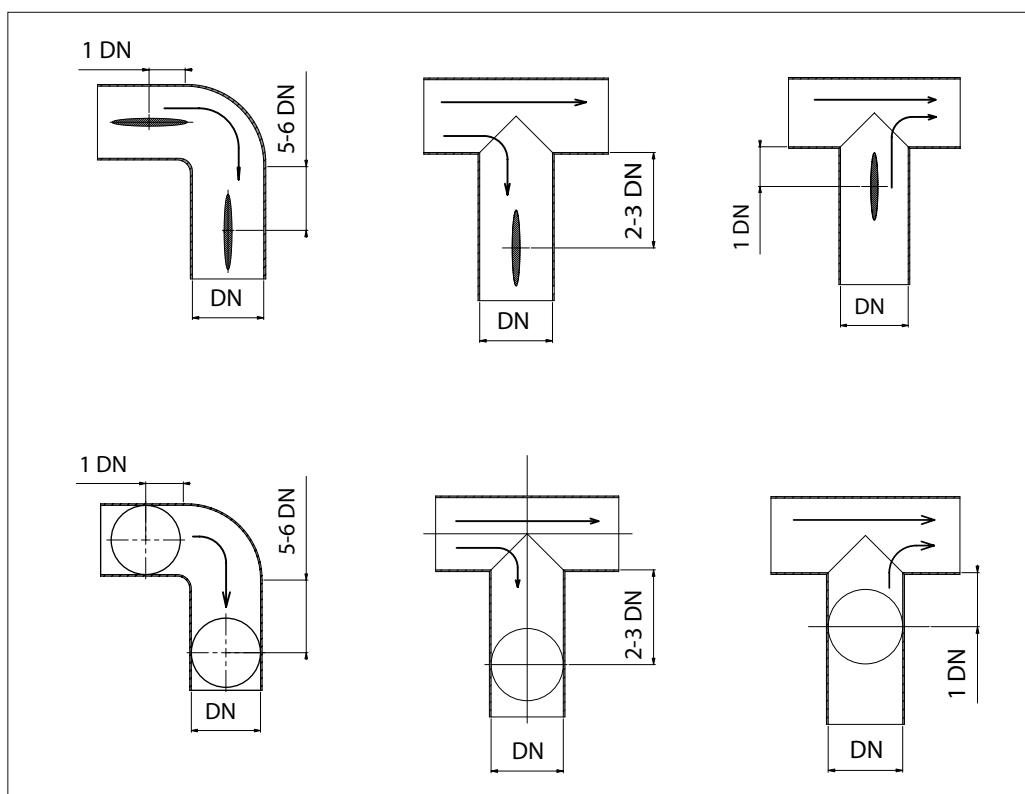

P-T diagram

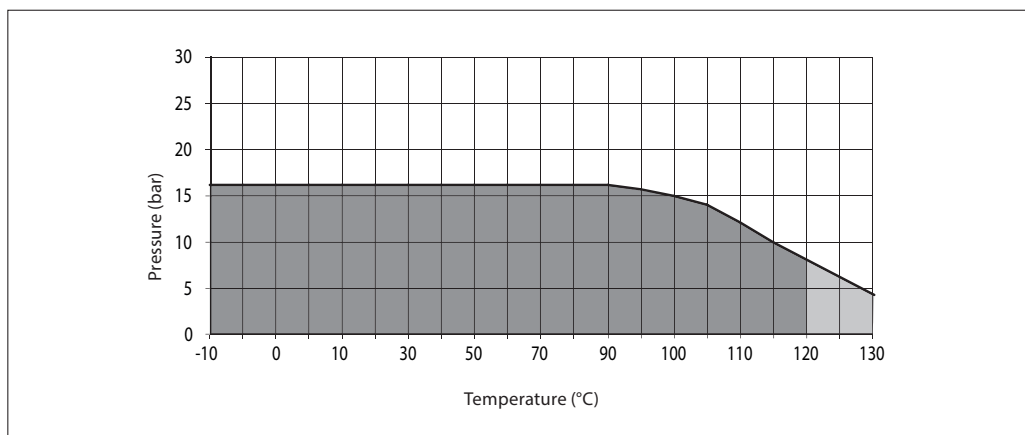

Headloss diagram
For water at 20 °C

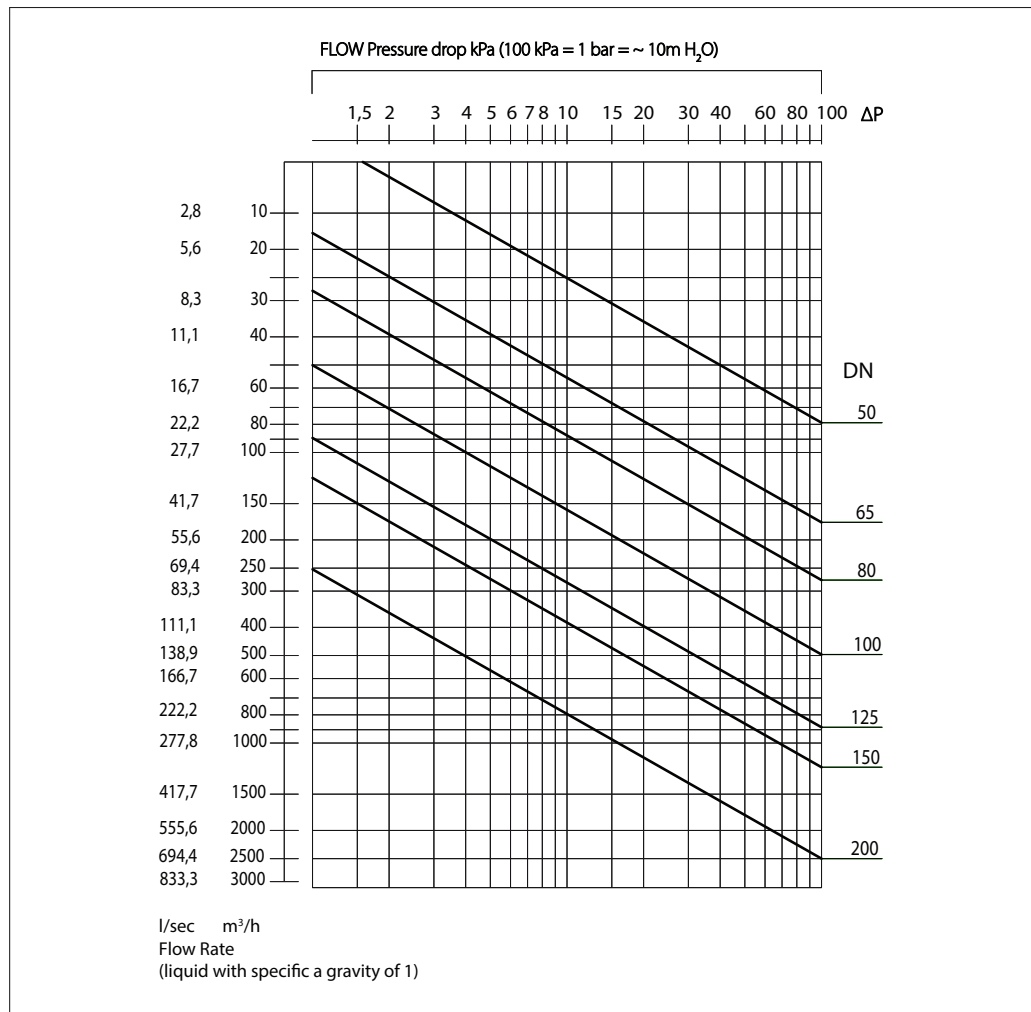

Design

1. Body
2. Disc
3. Shaft
4. Liner
5. Circlip
6. O-ring
7. Upper guide bush
8. Lower guide bush
9. Gear box

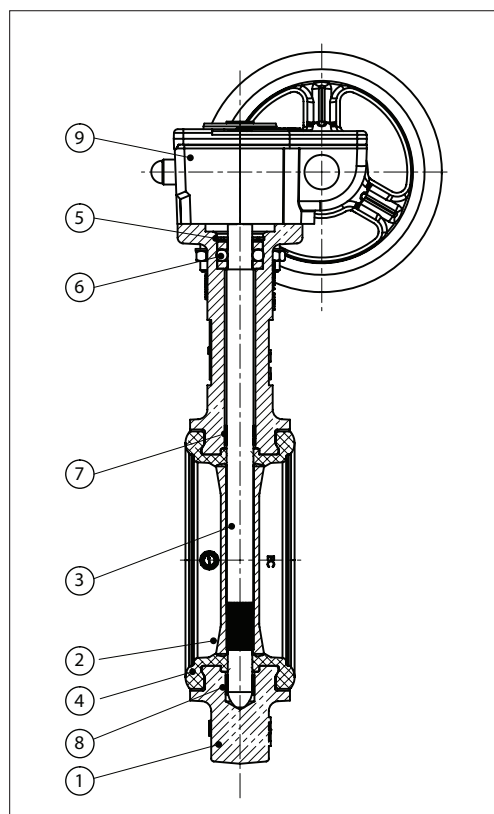

Dimensions

Waffer type VFY-WG

DN	Ø	A	B	C	D	ØE	Weight (kg)
50	54	62	225.5	120	43	125	3.6
65	70	70	234.5	120	46	125	4
80	85	89	240.5	120	46	125	4.3
100	100	106	264.5	120	52	125	6.3
125	125	120	279.5	120	56	125	7.4
150	150	131	292.5	120	56	125	8.5
200	200	166	315	120	60	125	12.3

Lug type VFY-LG

DN	Ø	A	B	C	D	ØE	Weight (kg)
50	54	62	225.5	120	43	125	4
65	70	70	234.5	120	46	125	4.5

Lug type VFY-LG

DN	Ø	A	B	C	D	ØE	Weight (kg)
80	85	89	240.5	120	46	125	5.4
100	100	103	264.5	120	52	125	7.9
125	125	119	279.5	120	56	125	9.9
150	150	133	292.5	120	56	125	11.9

Lug type VFY-LG

DN	Ø	A	B	C	D	ØE	Weight (kg)
200	200	162	315	120	60	125	17



Data sheet

VFY-WG, VFY-LG

Directive 2014/68/UE
Equipments under pressure

Products manufactured in conformity with the requirements of the directive, according to pressure, DN and fluid. Relevant for countries following this Directive (ie, PED)

Family	DN (mm)	Cat.	Mounting	PFA	PS				
				water	L1	L2	G1	G2	
VFY DN25 to 350 mm with EPDM liner	10 bar	25 to 100	4§3	Flanges	10	10	10	-	10
				End of line	6	6	6	-	6
		125 to 350	I	Flanges	10	10	10	-	10
				End of line	6	6	6	-	6
	16 bar	32 to 100	4§3	Flanges	16	16	16	-	10
				End of line	12	12	12	-	10
		125	I	Flanges	16	16	16	-	10
				End of line	12	12	12	-	10
		150	I	Flanges	16	10	16	-	10
				End of line	12	6	12	-	10
		200 to 300	I	Flanges	16	10	16	-	10
				End of line	10	6	10	-	10
	350	I	Flanges	16	10	16	-	10	
			End of line	8	6	8	-	8	
	20 bar	32 to 250	4§3	Flanges	20	-	20	-	-
				End of line	12	-	12	-	-
		300 to 350	I	Flanges	20	-	20	-	-
				End of line	12	-	12	-	-
25 bar	32 to 150	4§3	Flanges	25	-	25	-	-	
			End of line	16	-	16	-	-	
VFY DN400 to 1200 mm with EPDM liner	10 bar	400 to 1200	I	Flanges	10	10	10	-	-
				End of line	6	6	6	-	-
	16 bar	400 to 1200	I	Flanges	16	-	16	-	-
				End of line	8	-	8	-	-
	20 bar	400 to 600	I	Flanges	20	-	20	-	-
				End of line	10	-	10	-	-
PS: Maximum allowable pressure (bars) in accordance with directive 2014/68/EC PFA: Allowable operating pressure (bars) for supply, distribution and disposal of water				L1: Group 1 liquid - Hazardous fluid category L2: Group 2 liquid - Other fluids G1: Group 1 gas - Hazardous gas category G2: Group 2 gas - Other gasses					

Danfoss A/S

Climate Solutions • danfoss.com • +45 7488 2222

Any information, including, but not limited to information on selection of product, its application or use, product design, weight, dimensions, capacity or any other technical data in product manuals, catalogues descriptions, advertisements, etc. and whether made available in writing, orally, electronically, online or via download, shall be considered informative, and is only binding if and to the extent, explicit reference is made in a quotation or order confirmation. Danfoss cannot accept any responsibility for possible errors in catalogues, brochures, videos and other material. Danfoss reserves the right to alter its products without notice. This also applies to products ordered but not delivered provided that such alterations can be made without changes to form, fit or function of the product.
All trademarks in this material are property of Danfoss A/S or Danfoss group companies. Danfoss and the Danfoss logo are trademarks of Danfoss A/S. All rights reserved.