

Data Sheet

Hot gas bypass regulator
Type **KVC**

Adapts compressor capacity to actual evaporator load



KVC is a hot gas bypass regulator applied for the adaption of the compressor capacity to the actual evaporator load.

Placed in a bypass between high and low pressure sides of the refrigeration system, KVC imposes a lower limit on the compressor suction pressure by supplying the low pressure side with replacement capacity in the form of hot gas / cool gas from the high pressure side.

Features

- Accurate, adjustable pressure regulation
- Wide capacity and operating ranges
- Pulsation damping design
- Stainless steel bellows
- Compact angle design for easy installation
- "Hermetic" brazed construction
- Available with flare and ODF solder connections
- May be used in the following EX range: Category 3 (Zone 2)

Functions

Figure 1: Design/Function for KVC

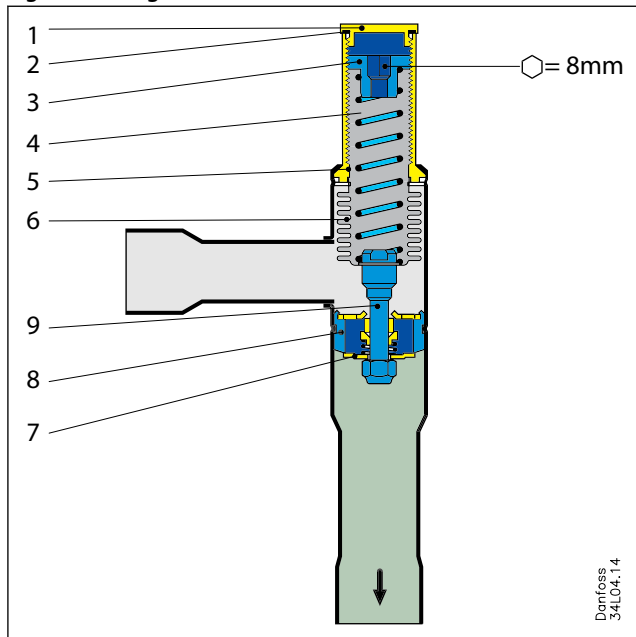

1	Protective cap
2	Gasket
3	Setting screw
4	Main spring
5	Valve body
6	Equalization bellows
7	Valve plate
8	Valve seat
9	Damping device

The hot gas bypass regulator KVC opens at a fall in pressure on the outlet side, i.e. when the pressure in the evaporator is beyond the set value.

KVC regulates only in dependence on the outlet pressure. Pressure variations on the inlet side of the regulator do not affect the degree of opening since KVC is equipped with an equalization bellows (6). This bellows has an effective area corresponding to that of the valve seat.

The hot gas bypass regulator is also equipped with an effective damping device (9) against pulsations which can normally arise in a refrigeration plant.

The damping device helps to ensure long life for the regulator without impairing regulation accuracy.

Figure 2: P-band and Offset

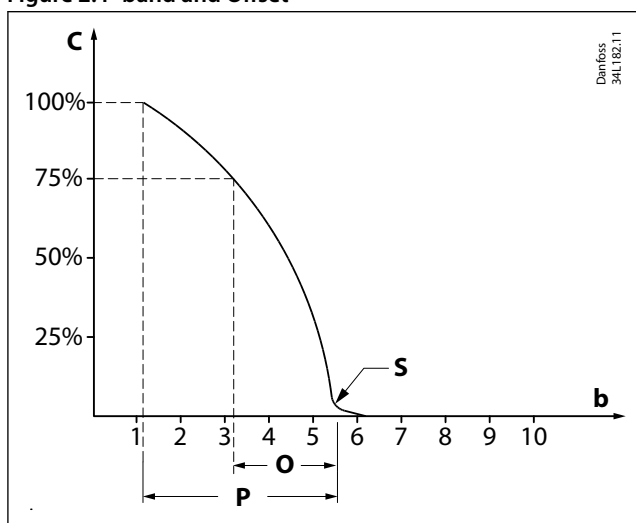

C	Capacity
b	bar
S	Set point
O	offset
P	P- band

Proportional band

The proportional band or P-band is defined as the amount of pressure required to move the valve plate from closed to full open position.

Example

If the valve is set to open at 4 bar and the valve p-band is 2, the valve will give maximum capacity when the discharge pressure reaches 2 bar.

Offset

The offset is defined as the permissible pressure variation in suction line pressure (temperature). It is calculated as the difference between the required working pressure and the minimum allowable pressure. The offset is always a part of the P-band.

Example with R404A

A suction temperature ahead of the compressor of 5 °C ~ 6 bar is required, and the temperature must not drop below 0 °C ~ 5 bar. The offset will then be 1 bar.

Product specification

Technical data

Table 1: Technical data for KVC

Features	Description
Refrigerants	R22, R134a, R290, R404A, R407A, R407C, R407F, R407H, R448A, R449A, R449B, R450A, R452A, R454A, R454C, R455A, R507A, R513A, R515B, R516A, R600, R600a, R1234ze(E), R1234yf, R1270
Regulating range	0.2 – 6.0 bar Factory setting = 2 bar
Maximum working pressure	PS/MWP PS = 28 bar
Maximum test pressure	Pe = 31 bar
Medium temperature range	-45 – 130 °C
Maximum P-band	2.0 bar
K _v -value ⁽¹⁾ with maximum P-band	KVC 12 = 0.68 m ³ / h
	KVC 15 = 1.25 m ³ / h
	KVC 20 = 1.85 m ³ / h

⁽¹⁾ The K_v value is the flow of water in [m³ / h] at a pressure drop across valve of 1 bar, ρ = 1000 kg / m³.

This product is evaluated for R290, R454A, R454C, R455A, R600, R600a, R1234ze(E), R1234yf, R1270 by ignition source assessment in accordance with standard EN ISO80079-36. Flare connections are only approved for A1 and A2L refrigerants.

For complete list of approved refrigerants, visit store.danfoss.com and search for individual code numbers, where refrigerants are listed as part of technical data.

Replacement capacity

Table 2: Replacement capacity for R22

Type	Offset Δp [bar]	Q ⁽¹⁾ [kW] suction gas temperature ts after pressure / temperature reduction [°C]						
		-45	-40	-30	-20	-10	0	10
KVC 12	0.10	–	2.3	2.4	2.5	2.5	2.6	2.6
	0.15	–	3.5	3.6	3.7	3.8	3.9	4.0
	0.20	–	4.5	4.7	4.8	4.9	5.0	5.1
	0.30	–	5.9	6.1	6.3	6.4	6.5	6.7
	0.50	–	6.6	6.8	7.1	7.2	7.3	7.5
	0.70	–	7.0	7.2	7.4	7.6	7.8	7.9
	1.00	–	7.6	7.9	8.1	8.3	8.5	8.6
KVC 15	0.10	–	3.5	3.6	3.7	3.8	3.9	4.0
	0.15	–	4.5	4.7	4.8	4.9	5.0	5.1
	0.20	–	5.9	6.1	6.3	6.4	6.5	6.7
	0.30	–	8.2	8.5	8.7	8.9	9.1	9.3
	0.50	–	11.7	12.1	12.4	12.7	13	13.2
	0.70	–	13.7	14.2	14.6	14.9	15.2	15.5
	1.00	–	15.6	16.2	16.7	17.0	17.3	17.7
KVC 22	0.10	–	3.7	3.8	3.9	4.0	4.1	4.2
	0.15	–	5.1	5.2	5.4	5.5	5.6	5.7
	0.20	–	6.8	7.0	7.3	7.4	7.5	7.7
	0.30	–	8.4	8.6	8.9	9.1	9.3	9.5
	0.50	–	14.1	14.5	15.0	15.3	15.6	15.9
	0.70	–	17.6	18.1	18.7	19.1	19.5	19.9
	1.00	–	21.4	22.4	23.1	23.6	24.1	24.5
	1.20	–	23.8	24.6	25.4	25.9	26.4	26.9

⁽¹⁾ The capacities are based on: condensing temperature t_c = 25 °C.

Table 3: Replacement capacity for R134a

Type	Offset Δp	$Q^{(1)}$ [kW] suction gas temperature t_s after pressure / temperature reduction [°C]						
	[bar]	-45	-40	-30	-20	-10	0	10
KVC 12	0.10	–	–	1.4	1.4	1.5	1.7	1.7
	0.15	–	–	2.1	2.3	2.4	2.5	2.6
	0.20	–	–	2.9	3.0	3.1	3.2	3.4
	0.30	–	–	3.7	3.9	4.1	4.3	4.5
	0.50	–	–	4.2	4.3	4.5	4.8	4.9
	0.70	–	–	4.4	4.5	4.8	5.0	5.2
	1.00	–	–	4.8	5.0	5.2	5.5	5.8
	1.20	–	–	5.1	5.4	5.6	5.8	6.1
KVC 15	0.10	–	–	2.1	2.3	2.4	2.5	2.6
	0.15	–	–	2.9	3.0	3.1	3.2	3.4
	0.20	–	–	3.7	3.9	4.1	4.3	4.5
	0.30	–	–	5.1	5.4	5.6	5.8	6.1
	0.50	–	–	7.4	7.7	8.0	8.4	8.7
	0.70	–	–	8.7	9.1	9.4	9.9	10.2
	1.00	–	–	9.9	10.2	10.7	11.3	11.7
	1.20	–	–	10.6	11.1	11.6	12.2	12.6
KVC 22	0.10	–	–	2.3	2.4	2.5	2.6	2.8
	0.15	–	–	3.2	3.3	3.5	3.6	3.7
	0.20	–	–	4.3	4.4	4.6	4.9	5.1
	0.30	–	–	5.2	5.5	5.7	6.0	6.3
	0.50	–	–	8.9	9.3	9.7	10.1	10.5
	0.70	–	–	11	11.6	12.0	12.6	13.1
	1.00	–	–	13.7	14.3	14.9	15.6	16.3
	1.20	–	–	15.0	15.7	16.3	17.2	17.8

⁽¹⁾ The capacities are based on: condensing temperature $t_c = 25$ °C.

Table 4: Replacement capacity for R404A/R507

Type	Offset Δp	$Q^{(1)}$ [kW] suction gas temperature t_s after pressure / temperature reduction [°C]						
	[bar]	-45	-40	-30	-20	-10	0	10
KVC 12	0.10	–	1.9	2.0	2.1	2.2	2.3	2.4
	0.15	–	3.0	3.1	3.3	3.4	3.5	3.6
	0.20	–	3.9	4.1	4.2	4.5	4.7	4.7
	0.30	–	5.1	5.4	5.6	5.8	6.0	6.1
	0.50	–	5.7	6.0	6.4	6.6	6.8	7.0
	0.70	–	6.0	6.4	6.6	6.9	7.2	7.3
	1.00	–	6.6	6.9	7.2	7.5	7.8	8.0
	1.20	–	7.0	7.4	7.7	8.0	8.4	8.5
KVC 15	0.10	–	3.0	3.1	3.3	3.4	3.5	3.6
	0.15	–	3.9	4.1	4.2	4.5	4.7	4.7
	0.20	–	5.1	5.4	5.6	5.8	6.0	6.1
	0.30	–	7.0	7.4	7.7	8.0	8.4	8.5
	0.50	–	10.1	10.6	11.1	11.6	12.0	12.3
	0.7	–	11.8	12.5	13.0	13.6	14.1	14.4
	1.00	–	13.5	14.2	14.8	15.5	16.1	16.4
	1.20	–	14.5	15.3	16.0	16.6	17.3	17.7
KVC 22	0.10	–	3.2	3.3	3.5	3.6	3.7	3.8
	0.15	–	4.3	4.6	4.8	5.0	5.2	5.3
	0.20	–	5.8	6.1	6.4	6.7	7.0	7.1
	0.30	–	8.2	8.6	8.9	9.3	9.8	9.9
	0.50	–	12.1	12.8	13.4	13.9	14.4	14.7
	0.70	–	15.2	16.0	16.6	17.4	18.1	18.4
	1.00	–	18.8	19.8	20.7	21.5	22.4	22.8
	1.20	–	20.5	21.6	22.6	23.5	24.5	25.0

⁽¹⁾ The capacities are based on: condensing temperature $t_c = 25$ °C.

Table 5: Replacement capacity for R407C

Type	Offset Δp	$Q^{(1)}$ [kW] suction gas temperature t_s after pressure / temperature reduction [°C]						
	[bar]	-45	-40	-30	-20	-10	0	10
KVC 12	0.10	–	2.4	2.6	2.7	2.8	2.9	3.0
	0.15	–	3.7	3.9	4.0	4.2	4.3	4.6
	0.20	–	4.8	5.0	5.2	5.4	5.6	5.8
	0.30	–	6.3	6.5	6.9	7.0	7.2	7.6
	0.50	–	7.0	7.3	7.7	7.9	8.1	8.6
	0.70	–	7.4	7.7	8.1	8.4	8.7	9.0
	1.00	–	8.1	8.5	8.8	9.1	9.4	9.8
	1.20	–	8.7	9.1	9.5	9.8	10.1	10.6
KVC 15	0.10	–	3.7	3.9	4.0	4.2	4.3	4.6
	0.15	–	4.8	5.0	5.2	5.4	5.6	5.8
	0.20	–	6.3	6.5	6.9	7.0	7.2	7.6
	0.30	–	8.7	9.1	9.5	9.8	10.1	10.6
	0.50	–	12.4	12.9	13.5	14.0	14.4	15
	0.70	–	14.5	15.2	15.9	16.4	16.9	17.7
	1.00	–	16.5	17.3	18.2	18.7	19.2	20.2
	1.2	–	17.8	18.6	19.5	20.1	20.8	21.7
KVC 22	0.10	–	3.9	4.1	4.3	4.4	4.6	4.8
	0.15	–	5.4	5.6	5.9	6.1	6.2	6.5
	0.20	–	7.2	7.5	8.0	8.1	8.3	8.8
	0.30	–	8.9	9.2	9.7	10.0	10.3	10.8
	0.50	–	14.9	15.5	16.4	16.8	17.3	18.1
	0.70	–	18.7	19.4	20.4	21.0	21.6	22.7
	1.00	–	22.7	24.0	25.2	26.0	26.8	27.9
	1.20	–	25.2	26.3	27.7	28.5	29.3	30.7

⁽¹⁾ The capacities are based on: condensing temperature $t_c = 25$ °C.

Correction factors

When selecting, the required regulator capacity is to be multiplied by a correction factor dependent on the condensing temperature.

System capacity \times correction factor = table capacity

The corrected capacity can then be found from the table. Correction factors for condensing temperature can be found in section "selection".

Sizing

For optimum performance, it is important to select a KVC valve according to system conditions and application.

The following data must be used when sizing a KVC valve:

- Refrigerant
- Minimum suction temperature: T_s in [°C] / [bar]
- Condensing temperature: t_c in [°C]
- Compressor load in [kW]
- Evaporator load in [kW]
- Connection type: flare or solder
- Connection size in [in.]

Valve selection

Example

When selecting the appropriate valve it may be necessary to convert the actual evaporator capacity using a correction factor. This is required when your system conditions are different than the table conditions. The selection is also dependant on the acceptable pressure drop across the valve.

The following example illustrates how this is done:

Hot gas bypass regulator, Type KVC

- Refrigerant: R134a
- Minimum suction temperature: $t_s = -12\text{ °C} \sim 0.9\text{ bar}$
- Compressor capacity at $-12\text{ °C} = 15.4\text{ kW}$
- Evaporator load at $-12\text{ °C} = 10.0\text{ kW}$
- Condensing temperature: $t_l = 35\text{ °C}$
- Connection type: Solder
- Connection size: $\frac{5}{8}\text{ in.}$

Step 1

Determine the correction factor for condensing temperature t_l .

Table 6: Correction factors for liquid temperature t_l

t_l [°C]	10	15	20	25	30	35	40	45	50
R134a	0.88	0.92	0.96	1.0	1.05	1.10	1.16	1.23	1.31
R22	0.9	0.93	0.96	1.0	1.05	1.10	1.13	1.18	1.24
R404A/R507	0.84	0.89	0.94	1.0	1.07	1.16	1.26	1.4	1.57
R407C	0.88	0.91	0.95	1.0	1.05	1.11	1.18	1.26	1.35

Step 2

The required replacement capacity is defined as the (compressor capacity – the evaporator load) divided by the correction factor = $(15.4 - 10.0) / 1.10 = 4.9\text{ kW}$

Step 3

Now select the appropriate capacity table and choose the column for minimum suction temperature $t_s = -20\text{ °C}$.

Using the corrected replacement capacity, select a valve that provides an equivalent or greater capacity than required.

KVC 15 delivers 5.4 kW at an offset of 0.3 bar. Based on the required connection size of $\frac{5}{8}\text{ in. ODF}$, the KVC 15 is the proper selection for this example.

Step 4

KVC 15, $\frac{5}{8}\text{ in.}$ solder connection: code no. 034L0147, see [Table 8: Ordering for type KVC](#).

Valve selection based on capacity calculation

As for extended capacity calculations and valve selection based on capacities and refrigerants, please refer to Coolselector®2. Rated and extended capacities are calculated with the Coolselector®2 calculation engine to ARI standards with the ASEREP equations based on laboratory measurements of selected valves.

Dimensions and Weight

Figure 3: Dimensions for KVC

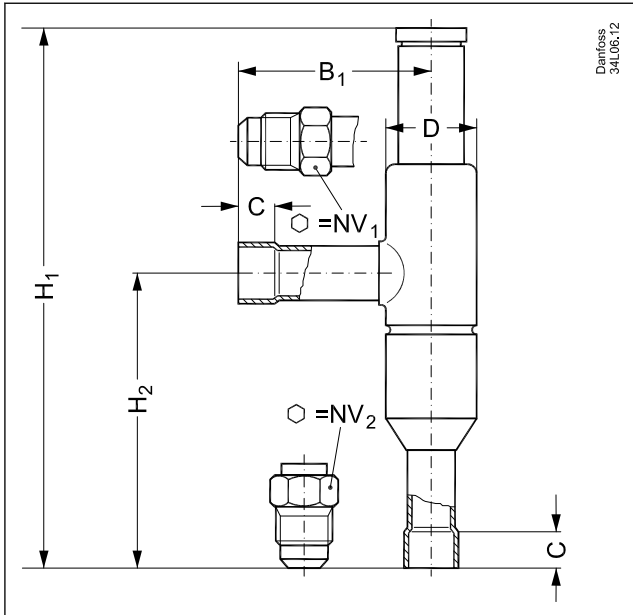

Table 7: Dimensions and Weight for KVP

Type	Connection				NV ₁ [mm]	NV ₂ [mm]	H ₁ [mm]	H ₂ [mm]	B ₁ [mm]	C solder [mm]	øD [mm]	Net weight [Kg]
	Flare		Solder ODF									
	[in.]	[mm]	[in.]	[mm]								
KVC 12	1/2	12	1/2	12	19	24	179	99	64	10	30	0.4
KVC 15	5/8	16	5/8	16	24	24	179	99	64	12	30	0.4
KVC 22	-	-	5/8	22	-	-	179	99	64	17	30	0.4

Ordering

Figure 4: Flare connection Figure 5: Solder connection

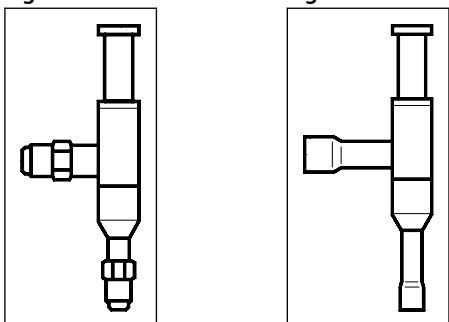

Table 8: Ordering for type KVC

Type	Rated capacity ⁽¹⁾ [kW]				Flare connection ⁽²⁾		Code no.	Solder connection		Code no.
	R22	R134a	R404A/R507	R407C	[in]	[mm]		[in]	[mm]	
KVC 12	7.6	4.8	6.9	8.4	1/2	12	034L0141	1/2	–	034L0143
	7.6	4.8	6.9	8.4	–	–	–	–	12	034L0146
KVC 15	14.9	9.4	13.6	16.4	5/8	16	034L0142	5/8	16	034L0147
KVC 22	19.1	12.0	17.4	21.0	–	–	–	7/8	22	034L0144

⁽¹⁾ Rated capacity is the regulator capacity at

- evaporating temperature $t_e = -10\text{ °C}$
- condensing temperature $t_c = 25\text{ °C}$
- offset = 0.7 bar

⁽²⁾ KVC supplied without flare nuts. Separate flare nuts can be supplied:

- 1/2 in / 12 mm, code no. 011L1103
- 5/8 in / 16 mm, code no. 011L1167

The connection dimensions chosen must not be too small, since gas velocities in excess of 40 m/s at the inlet of the regulator can give flow noise.

If the discharge tube temperature becomes too high in relation to the compressor specification, the installation of an injection valve in a bypass between liquid line and compressor suction line is recommended.

Certificates, declarations, and approvals

The list contains all certificates, declarations, and approvals for this product type. Individual code number may have some or all of these approvals, and certain local approvals may not appear on the list.

Some approvals may change over time. You can check the most current status at danfoss.com or contact your local Danfoss representative if you have any questions.

Table 9: Certificates, declarations, and approvals

Document name	Document type	Document topic	Approval authority
UL SA7200	Mechanical - Safety Certificate		UL
034R9541.AA	Manufacturers Declaration	China RoHS	Danfoss
034L9630.AA	Manufacturers Declaration	ATEX	Danfoss

Online support

Danfoss offers a wide range of support along with our products, including digital product information, software, mobile apps, and expert guidance. See the possibilities below.

The Danfoss Product Store



The Danfoss Product Store is your one-stop shop for everything product related—no matter where you are in the world or what area of the cooling industry you work in. Get quick access to essential information like product specs, code numbers, technical documentation, certifications, accessories, and more.

Start browsing at store.danfoss.com.

Find technical documentation



Find the technical documentation you need to get your project up and running. Get direct access to our official collection of data sheets, certificates and declarations, manuals and guides, 3D models and drawings, case stories, brochures, and much more.

Start searching now at www.danfoss.com/en/service-and-support/documentation.

Danfoss Learning



Danfoss Learning is a free online learning platform. It features courses and materials specifically designed to help engineers, installers, service technicians, and wholesalers better understand the products, applications, industry topics, and trends that will help you do your job better.

Create your Danfoss Learning account for free at www.danfoss.com/en/service-and-support/learning.

Get local information and support



Local Danfoss websites are the main sources for help and information about our company and products. Find product availability, get the latest regional news, or connect with a nearby expert—all in your own language.

Find your local Danfoss website here: www.danfoss.com/en/choose-region.

Coolselector®2 - find the best components for you HVAC/R system



Coolselector®2 makes it easy for engineers, consultants, and designers to find and order the best components for refrigeration and air conditioning systems. Run calculations based on your operating conditions and then choose the best setup for your system design.

Download Coolselector®2 for free at coolselector.danfoss.com.

Danfoss A/S

Climate Solutions • danfoss.com • +45 7488 2222

Any information, including, but not limited to information on selection of product, its application or use, product design, weight, dimensions, capacity or any other technical data in product manuals, catalogues descriptions, advertisements, etc. and whether made available in writing, orally, electronically, online or via download, shall be considered informative, and is only binding if and to the extent, explicit reference is made in a quotation or order confirmation. Danfoss cannot accept any responsibility for possible errors in catalogues, brochures, videos and other material. Danfoss reserves the right to alter its products without notice. This also applies to products ordered but not delivered provided that such alterations can be made without changes to form, fit or function of the product.

All trademarks in this material are property of Danfoss A/S or Danfoss group companies. Danfoss and the Danfoss logo are trademarks of Danfoss A/S. All rights reserved.