

Read all instructions thoroughly

INSTRUCTIONS

EC FAN SPEED CONTROLLER

Type XGE



IMPORTANT

Failure to read and follow all instructions carefully before installing or operating this Fan Speed Controller could cause personal injury and/or property damage. Save these instructions for future use.

NOTES FOR SAFETY

⚠ WARNING

- Before wiring and service, be sure to turn off power supply. Otherwise, may cause electrical shock.
- Before F.V.S. adjusting, connection of a plug and disassembly of a plug, be sure to turn off power supply as it may cause electrical shock.
- Do not touch the main body during driving. Otherwise, it may burn a hands.

OUTLINE

The XGE-*SE fan speed controllers are designed for speed control of electronically commutated (EC) fan motors. The XGE controls Fan Motor Speed of air cooled condenser of general purpose cold/cooling unit, and keeps a definite condensing pressure and makes it to drive stably.

MOUNTING

Directly mount onto the pressure line (see Fig.1a) in a location where pressure can be detected accurately (e. g. After the condenser) Alternatively it is possible to remote mount to a side panel using the optional fixing bracket (see Fig.8) and connect to the pressure line with a refrigeration pipe (not supplied).

⚠ CAUTION

- Don't install at the place to require degrees of protection over IP65 Category 2 enclosures.
- Don't tighten with excessive force whilst holding the unit, since this can result in deformation of the controller. For direct mounting, tighten the connection using an appropriately sized spanner and a torque of 12.7-15Nm (see Fig.2).
- The mounting position should be in the vertical axis and should not be fitted more than 45° from the vertical (see Fig.1b).
- Failure to install the Copper Packing at the connection portion cause leak of refrigerant gas.
- Provide adequate ventilation space so that heat doesn't build up. At least 50mm clearance above the top and below the bottom of XGE is necessary. Don't mount this instrument directly above equipment that generates large amount of heat. (heaters, transformers, large-wattage resistors.)
- Don't give strong impact over 100G. This may result changing in properties and breakage.

WIRING

Please refer wiring diagram (Fig.6) to connect the plug (supplied). When the plug has wired, refer Fig.5 to mount the plug, and fix by screw (supplied). The plug can wire so that orientation is possible in 4 directions as desired. (see Fig. 7)

⚠ CAUTION

- For connecting motor, use Fan Motor (SELV circuit) that isolated the primary circuit(Fan Motor main AC) and the secondary circuit(Fan Speed Controller).
- Cable length for connecting the Fan Speed Controller and Fan Motor should be less than 10m.
- Fix the plug onto the XGE, using the gasket provided and securely tighten with the screw (also provided) using a torque of 0.4-0.6Nm (see Fig.5).

CAUTION: It is important to use the gasket (DIN 43650) between the plug and controller as well as tightening the screw sufficiently to avoid the risk of electrical shock or short circuit.

ADJUSTING (see Fig. 4)

Turn the Range Adjusting Screw to clockwise (+) for increasing the setting value, and to counterclockwise (-) for decreasing the setting value.

⚠ CAUTION

- Do not move the screw other than the Range Adjusting Screw.
- Please do not apply more than 0.35Nm torque to the range adjusting screw. If applied torque excess over 0.35Nm, a part of resin-made case may be broken and it may be impossible to adjust the range.

CONFIRMATION OF OPERATION

All customers using this Product (hereinafter referred to as "Customers") are requested to, after properly installing this Product, test the operation of this Product to confirm that all the systems in connection with this Product fully function. In order to prevent the occurrence of bodily injury, fire accidents, serious damage, etc., in connection with the Customers' machinery or equipment due to improper installation of this Product, Saginomiya kindly requests the Customers to take the necessary safety measures by preparing safe designs such as a fail-safe design (*1) and a fire spread prevention design, as well as to make the proper adjustments for product reliability necessary for fault-tolerance (*2).

(*1) Fail-safe design: Design to ensure safety in the event of any mechanical failure

(*2) Fault-tolerance: Utilization of redundancy technology

Periodic Inspection of this Product

Be sure to confirm the proper operation of this Product and keep records of such operation at least once a year. Saginomiya shall be held harmless and be indemnified by the Customers from any damages incurred due to the Customers failing to conduct the above operational procedures, provided, however, that, this shall not apply if the damages which the Customer incurred due to the defect of this Product caused by Saginomiya.

⚠ CAUTION

- It can not be used for ammonia refrigeration system.
- This product is not available for the system which apply pressure more than 4.7MPa [47bar] because the rated maximum working pressure of this product is 4.7MPa [47bar] if the pressure more than the rated maximum working pressure is applied to this product, it causes transformation of characteristics or the destruction. Operation will become unstable when using other than sine waves for the power supply. In this case, proper control may be achieved.

RESTRICTIONS OF USE

This Product is designed and manufactured for the purpose of using them for cooling and heating and refrigerating appliances and air conditioning equipment or various industrial equipment, but is not designed and manufactured for the purpose of using this Product for any instrument or system related to human life or health purposes. Therefore, the use of this Product in fields related to items (1) through (3) below is not intended whatsoever. Saginomiya shall be held harmless and be indemnified from any and all damages incurred by use of this Product under item (3).

- (1) In any field related to nuclear power and radiation;
- (2) In any field related to space or seafloor equipment;
- (3) In any equipment or device requiring a high degree of reliance on such equipment or device with respect to which it is reasonably foreseeable that failure or malfunction of the equipment or device would either directly or indirectly cause serious damage to human life, health or property;

Also, when using this Product under the fields related to items (1) through (9), (except for item (3), in relation to which this Product must never be used), please be sure to notify our Saginomiya's contact desk in charge of sales and obtain Saginomiya's prior written approval for such use. Saginomiya shall be held harmless and be indemnified from any and all damages incurred by use of this Product in relation to these fields if the Customers do not notify Saginomiya's contact desk and obtain Saginomiya's prior written approval.

- (4) Transportation device (railroad, aviation, ship or vessel, vehicle equipment, etc.);
- (5) Disaster-prevention or crime-prevention device;
- (6) Facility or application directly related to medical equipment, burning appliances, electro thermal equipment, amusement rides and devices, facilities/applications associated directly with billing, or device using flammable fluid;
- (7) Equipment requiring high reliance on supply systems such as electricity, gas, water, etc., in large-scale communication system, or in transportation or air traffic control system;
- (8) Facilities that are to comply with regulations of governmental / public agencies or specific industries or
- (9) Other machineries or equipment equivalent to those set forth in the above items (4) to (8) which require for high reliability and safety.

It is recommended to replace this Product within 5 to 10 years of delivery if no other duration of use is provided in the applicable specifications or instruction manual because the conditions and environment of use also have an impact on this Product.

SCOPE OF WARRANTY

SAGINOMIYA WILL PROVIDE THE CUSTOMERS WITH REPLACEMENT OR REPAIRED THIS PRODUCT DELIVERED, FREE OF COST, ONLY WITHIN ONE YEAR OF DELIVERY TO THE CUSTOMER, IF FAILURE OCCURS IN THE CUSTOMERS' EQUIPMENT USING THIS PRODUCT DUE TO A DEFECT OF THIS PRODUCT; PROVIDED, HOWEVER, THAT IN ANY EVENT THE RATIO OF THE AMOUNT THAT SAGINOMIYA BEARS FOR THE DAMAGES INCURRED BY THE FAILURE OF THIS PRODUCT OR CUSTOMERS' EQUIPMENT SHALL NOT EXCEED THE PRICE OF THIS PRODUCT WE DELIVERED. IN ADDITION, SAGINOMIYA SHALL BE HELD HARMLESS AND BE INDEMNIFIED FROM ANY AND ALL DAMAGES INCURRED WHEN THE FAILURE OF THE CUSTOMERS' EQUIPMENT OCCURRED DUE TO ANY CAUSE SET FORTH BELOW.

- (1) WHEN CAUSED BY INAPPROPRIATE HANDLING OR USE OF THIS PRODUCT BY THE CUSTOMERS (SUCH AS NOT COMPLYING WITH THE CONDITIONS, ENVIRONMENTAL SPECIFICATIONS OR CAUTIONS INDICATED IN ANY APPLICABLE CATALOGUE, SPECIFICATIONS, INSTRUCTION MANUAL, ETC.);
- (2) WHEN FAILURE OCCURRED DUE TO ANY REASON OTHER THAN THIS PRODUCT;
- (3) WHEN CAUSED BY MODIFICATION OR REPAIR OF THIS PRODUCT MADE BY ANYONE OTHER THAN SAGINOMIYA OR DESIGNEE OF SAGINOMIYA;
- (4) WHEN CAUSED BY THE USE OF THIS PRODUCT IN VIOLATION OF THE ABOVE "RESTRICTIONS OF USE" OR "CONFIRMATION OF OPERATION";
- (5) WHEN SUCH FAILURE WAS NOT REASONABLY FORESEEABLE AT THE TIME OF SAGINOMIYA'S SHIPMENT; OR
- (6) BY ANY OTHER CAUSE NOT ATTRIBUTABLE TO SAGINOMIYA, SUCH AS AN ACT OF GOD, DISASTER, OR ACT OF ANY THIRD PARTY.

PLEASE NOTE THAT THE CUSTOMERS WILL NOT BE ENTITLED TO ANY OF THE ABOVE WARRANTY IF THE CUSTOMERS PURCHASED THIS PRODUCT FROM INTERNET AUCTION, ETC.

SPECIFICATIONS

Catalog No.	F.V.S. Setting bar [Psi]		E. P. B. bar [Psi]	Refrigerants	Supply Voltage [VDC]	Output Voltage [VDC]	Pressure Connections	Mass of the Equipment [g]
	Factory Set	Adjusting Range Min. Max.						
XGE-2SE**	8 [116]	8 [116] 18 [261]	Fixed 4.5 [65]	R134a	10 (Supplied Voltage from EC Fan Motor)	0 to 10	7/16-20UNF Female Flare Fitting with Schraeder or 7/16-20UNF male Flare Fitting	140
XGE-4SE**	19 [276]	10 [145] 25 [362]	Fixed 6 [87]	R22, R404A, R407C				
XGE-6SE**	28 [406]	22 [319] 39 [566]	Fixed 7 [101]	R410A				

F.V.S. : Full Voltage Set point
This is pressure that output voltage output 95% of supply voltage.

E.P.B. : Effective Proportional Band
This is difference of pressure between output voltage output 5% and 95% of supply voltage.

Ambient Temperature of Fan Speed Controller Housing:-20 to 55°C / Vibration:2G or less in normal use. / Shock:100G or less / Altitude:2000m / Humidity:0 to 90%RH
Special specification: F.V.S. Factory setting can be set the different points within the Adjusting Range on demand.
These model were approved UL Recognition (US):File E43867, CGN SDFY2
UL Recognition (Canada):File E43867, CGN SDFY8

[Selection of Catalog number] Example: XGE-2SEBI-US

① ② ③④ ⑤

①Refrigerants select	2: R134a, 4: R22, R407C, R404A, 6: R410A
②EC Fan Model	Fixed.
③Pressure connections	No symbol: 7/16-20UNF Female Flare Fitting with Schroeder B: 7/16-20UNF Male Flare Fitting
④Type of packing	No symbol: Packed by small box, 1: Packed by Big box
⑤Standard	US: UL Standard

DIMENSIONS

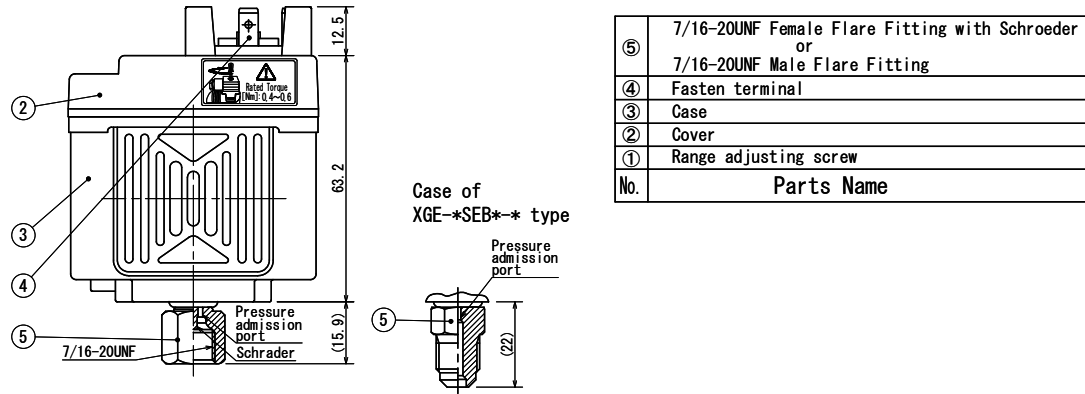
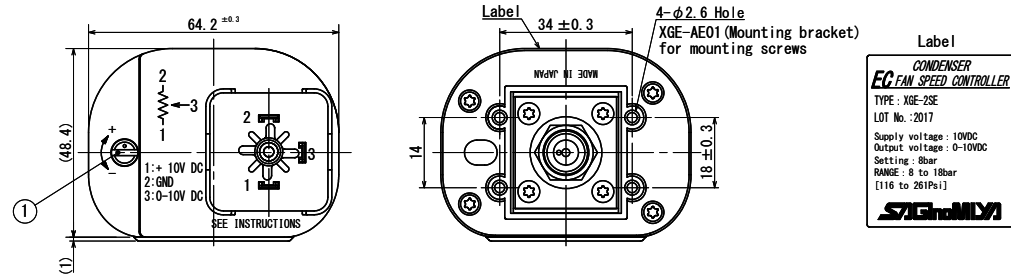

Option

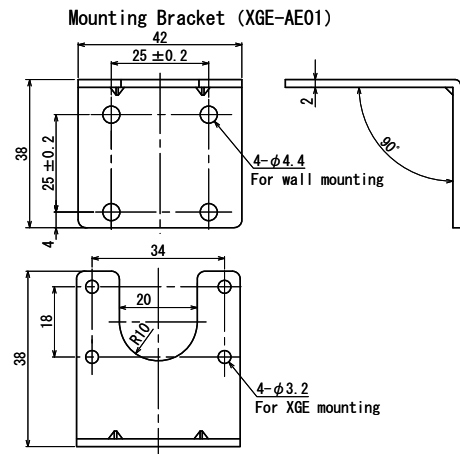

Accessory (Furnished)

