

Data Sheet

Shut-off valve Type **SVA-S** and **SVA-L**

Assures favorable flow characteristics in industrial refrigeration applications



SVA shut-off valves are available in angleway and straightway versions and with Standard neck (SVA-S) and Long neck (SVA-L)

The shut-off valves are designed to meet all industrial refrigeration application requirements and are designed to give favourable flow characteristics and are easy to dismantle and repair when necessary.

The valve cone is designed to ensure perfect closing and withstand a high system pulsation and vibration, which can be present specifically in the discharge line.

Features

- Applicable to HCFC, HFC, R717 (Ammonia), R744 (CO₂) and all flammable refrigerants.
- Modular Concept:
 - Each valve housing is available with several different connection types and sizes
 - Possible to convert SVA-S or SVA-L to any other product in the Flexline™ SVL family (hand operated regulating valve, check & stop valve, check valve or strainer) just by replacing the complete top part
- Fast and easy valve overhaul service. It is easy to replace the top part and no welding is needed
- Optional accessories:
 - Heavy duty industrial hand wheel for frequent operation
 - Cap for infrequent operation
- Available in angleway and straightway versions with Standard neck or Long neck (DN 15 to DN 40) for insulated systems
- Each valve type is clearly marked with type, size and performance range
- The valves and caps are prepared for sealing, to prevent operation by unauthorized persons, using a seal wire
- Internal metal backseating: – DN 6 - 65 (¼ - 2½ in.)
- Internal PTFE backseating: – DN 80 - 200 (3 - 8 in.)
- Can accept flow in both directions
- Housing and bonnet material is low temperature steel according to requirements of the Pressure Equipment Directive and other international classification authorities
- Equipped with stainless steel bolts
- Max. working pressure: 52 bar / 754 psig
- Temperature range: -60/+150 °C (-76/+302 °F)
- Classification: DNV, CRN, BV, EAC etc. To get an updated list of certification on the products please contact your local Danfoss Sales Company.

Media

Refrigerants

Applicable to HCFC, HFC, R717 (Ammonia), R744 (CO₂) and all flammable refrigerants.

New refrigerants

Danfoss products are continually evaluated for use with new refrigerants depending on market requirements.

When a refrigerant is approved for use by Danfoss, it is added to the relevant portfolio, and the R number of the refrigerant (e.g. R513A) will be added to the technical data of the code number. Therefore, products for specific refrigerants are best checked at store.danfoss.com/en/, or by contacting your local Danfoss representative.

Product specification

Design

Housing

Made of special, cold resistant steel.

Valve cone

The valve cone can be turned on the spindle, thus there will be no friction between the cone and the seat when the valve is opened and closed and the special design will avoid cone spin due to pulsation and vibration when the valve is in open position. A teflon tightening ring provides perfect sealing with minimum closing force.

Spindle

Made of polished stainless steel, ideal for leap seal sealing.

Packing gland

The low temperature packing gland ensures a perfect tightness in the range: $-60/+150\text{ }^{\circ}\text{C}$ ($-76/+302\text{ }^{\circ}\text{F}$). The packing glands are equipped with a scraper ring to prevent penetration of dirt and ice into the packing gland.

For special and/or high demanding applications/conditions which run with high constant temperatures, it is recommended to replace the packing gland with "HL Packing Gland" as spare part. For more information, please, contact your local Danfoss sales representative.

Installation

It is recommended that the valves be installed in the direction of flow indicated by the arrow on the valve body. The valve can be installed in the opposite direction but this slightly reduces the k_v -value (C_v -value).

The valve is designed to withstand high internal pressure. However, the piping system in general should be designed to avoid liquid traps and reduce the risk of hydraulic pressure caused by thermal expansion.

For further information refer to installation instructions for SVA.

Figure 1: Example of Marking Ring

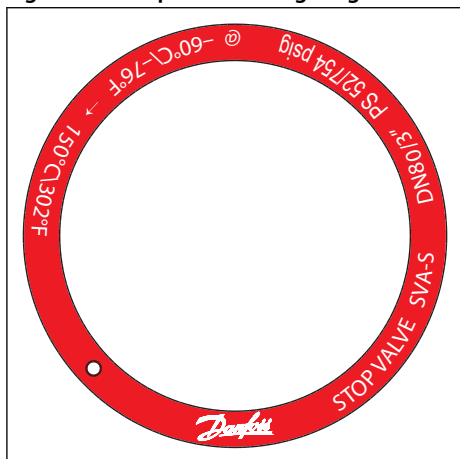

Pressure and temperature data

Table 1: Pressure and temperature

Description	Values
Temperature range	-60/+150 °C (-76/+302 °F)
Max. working pressure	52 bar / 754 psig

Maximum opening and closing pressure differential (for sizes 100 to 200)

Figure 2: Flow direction

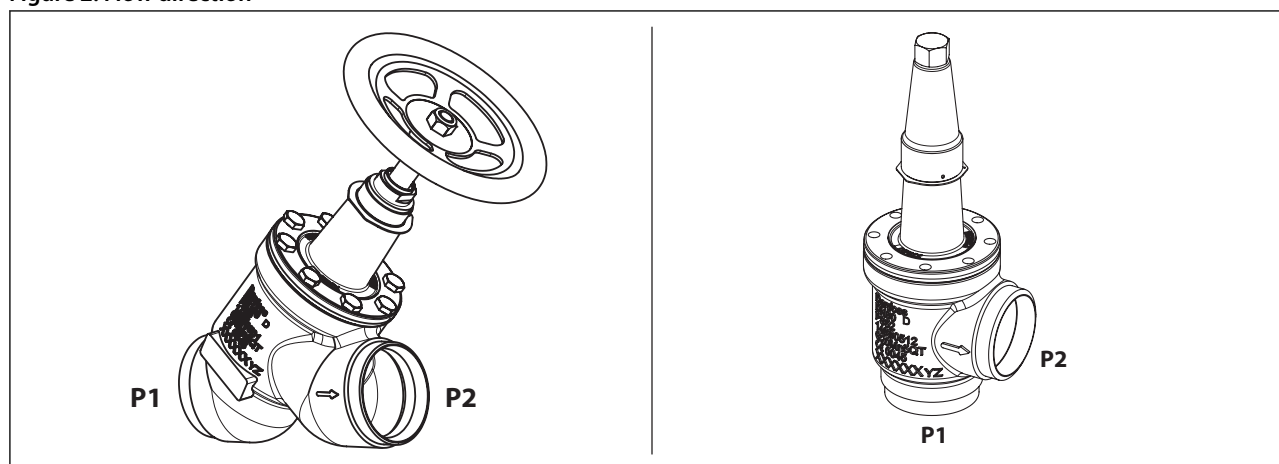

The maximum opening pressure differential is equal to the maximum pressure difference between inlet and outlet in the flow direction where the valve can be opened using normal hand force without damaging the valve.

The maximum closing pressure differential is equal to the maximum pressure difference between inlet and outlet in the flow direction where the valve is sealing according to specifications.

The maximum opening and closing pressure differentials are as default equal to the maximum operating pressure (PS or MWP) for valve sizes up to and including DN 80.

For valve sizes of DN 100 or larger than DN 100 the opening and closing pressure differential depends on the flow direction as shown below. Note that the default flow direction indicated by the flow arrow is P1 -> P2.

Table 2: Flow direction

Valve size [DN]	Flow direction		
	P1 → P2	P2 → P1	P2 → P1
	Maximum opening and closing pressure differential	Maximum closing pressure differential	Maximum opening pressure differential
100	44 bar / 638 psi	52 bar / 754 psi	44 bar / 638 psi
125	33 bar / 478 psi	52 bar / 754 psi	33 bar / 478 psi
150	21 bar / 304 psi	52 bar / 754 psi	21 bar / 304 psi
200	14 bar / 203 psi	52 bar / 754 psi	14 bar / 203 psi

Connections

Available with the following connections:

- Butt-weld DIN (EN 10220)
- Butt-weld ANSI (B 36.10 Schedule 80), DN 6 - 40 (¼ - 1½ in.)
- Butt-weld ANSI (B 36.10 Schedule 40), DN 50 - 200 (2 - 8 in.)
- Butt-weld GOST, (8734-75 and 8732-78) DN 10 - 150 (¾ - 6 in.)
- Socket Weld (ANSI B 16.11), DN 15 - DN 50 (½ - 2 in.)
- Outside pipe thread G ½ in. - G ¾ in. (ISO 228/1)
- FPT Female Pipe Thread, NPT (ANSI/ASME B 1.20.1), DN 15 - 32 (½ - 1¼ in.)
- Special combination (DN 20 only), Socket weld inlet, FPT ¾ in. outlet
- Special connections Butt-weld F, see (link to [AI174086419766_SVL](#))
- Butt-weld JIS (G 3454/3455 Schedule 80), DN 15 - 40 (½ - 1½ in.)
- Butt-weld JIS (G 3454/3455 Schedule 40), DN 50 - 150 (2 - 6 in.)

Shut-off valve, type SVA-S and SVA-L

Figure 3: DIN

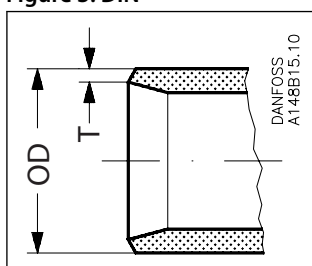

Table 3: Butt-weld DIN (EN 10220)

Size mm	Size in.	OD mm	T mm	OD in.	T in.	k_v -angle m ³ /h	k_v -straight m ³ /h	C_v -angle USgal/min	C_v -straight USgal/min
6	¼	13.5	2.3	0.531	0.091	2.9	2.0	3.4	2.4
10	⅜	17.2	2.3	0.677	0.091	4.5	3.2	5.2	3.6
15	½	21.3	2.3	0.839	0.091	7.0	4.9	8.1	5.7
20	¾	26.9	2.3	1.059	0.091	14.6	10.2	16.9	11.8
25	1	33.7	2.6	1.327	0.103	24.8	17.4	28.8	20.2
32	1¼	42.4	2.6	1.669	0.102	42.6	29.8	49.4	34.6
40	1½	48.3	2.6	1.902	0.103	45.2	31.6	52.4	36.7
50	2	60.3	2.9	2.37	0.11	80	65	93	76
65	2½	76.1	2.9	3	0.11	120	97	140	113
80	3	88.9	3.2	3.50	0.13	182	152	211	176
100	4	114.3	3.6	4.50	0.14	313	278	363	323
125	5	139.7	4.0	5.50	0.16	514	470	596	545
150	6	168.3	4.5	6.63	0.18	785	597	911	693
200	8	219.1	6.3	8.63	0.25	1168	1024	1355	1188

Figure 4: ANSI

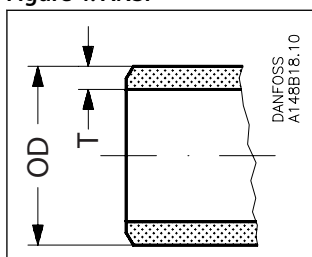

Table 4: Butt-weld ANSI (B 36.10 Schedule 80)

Size mm	Size in.	OD mm	T mm	OD in.	T in.	k_v -angle m ³ /h	k_v -straight m ³ /h	C_v -angle USgal/min	C_v -straight USgal/min
6	¼	13.5	3.0	0.531	0.118	2.9	2.03	3.4	2.4
10	⅜	17.2	3.2	0.677	0.126	4.5	3.15	5.2	3.6
15	½	21.3	3.7	0.839	0.146	7.0	4.9	8.1	5.7
20	¾	26.9	4.0	1.059	0.158	14.6	10.2	16.9	11.8
25	1	33.7	4.6	1.327	0.181	24.8	17.4	28.8	20.2
32	1¼	42.4	4.9	1.669	0.193	42.6	29.8	49.4	34.6
40	1½	48.3	5.1	1.902	0.201	45.2	31.6	52.4	36.7

Table 5: Butt-weld ANSI (B 36.10 Schedule 40)

Size mm	Size in.	OD mm	T mm	OD in.	T in.	k_v -angle m ³ /h	k_v -straight m ³ /h	C_v -angle USgal/min	C_v -straight USgal/min
50	2	60.3	3.9	2.37	0.15	80	65	93	76
65	2½	73.0	5.2	2.87	0.20	120	97	140	113
80	3	88.9	5.5	3.50	0.22	182	152	211	176
100	4	114.3	6.0	4.50	0.24	313	278	363	323
125	5	141.3	6.6	5.56	0.26	514	470	596	545
150	6	168.3	7.1	6.63	0.28	785	597	911	693
200	8	219.1	8.2	8.63	0.32	1168	1024	1355	1188

Shut-off valve, type SVA-S and SVA-L

Figure 5: GOST

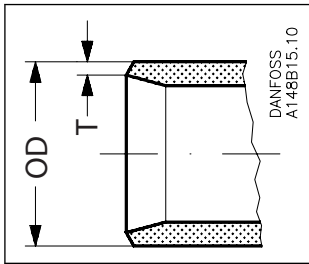

Table 6: Butt-weld GOST (8734-75 and 8732-78)

Size mm	Size in.	OD mm	T mm	OD in.	T in.	k_v -angle m ³ /h	k_v -straight m ³ /h	C_v -angle USgal/min	C_v -straight USgal/min
10	3/8	14	2	0.551	0.079	4.5	3.2	5.2	3.6
15	1/2	18	2	0.709	0.079	7	4.9	8.1	5.7
20	3/4	25	2.5	0.984	0.098	14.6	10.2	16.9	11.8
25	1	32	3	1.260	0.118	24.8	17.4	28.8	20.2
32	1 1/4	38	3	1.496	0.118	42.6	29.8	49.4	34.6
40	1 1/2	45	3	1.772	0.118	45.2	31.6	52.4	36.7
50	2	57	3.5	2.244	0.138	80	65	93	76
65	2 1/2	76.1	2.9	3	0.11	120	97	140	113
80	3	88.9	3.2	3.50	0.13	182	152	211	176
100	4	108	4	4.252	0.157	313	278	363	323
125	5	133	4	5.236	0.157	514	470	596	545
150	6	159	4.5	6.260	0.177	785	597	911	693

Figure 6: SOC

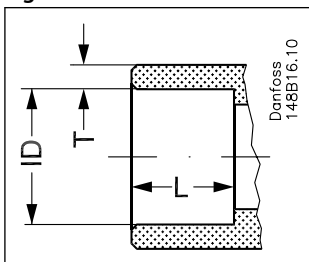
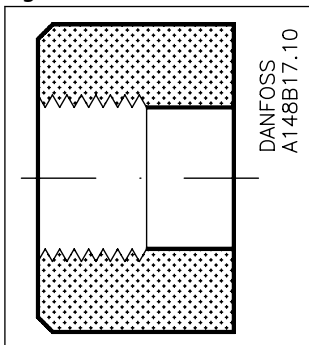

Table 7: Socket welding ANSI (B 16.11)

Size mm	Size in.	OD mm	T mm	OD in.	T in.	L mm	L in.	k_v -angle m ³ /h	k_v -straight m ³ /h	C_v -angle USgal/min	C_v -straight USgal/min
15	1/2	21.8	6.0	0.858	0.235	10	0.39	7.0	4.9	8.1	5.7
20	3/4	27.2	4.6	1.071	0.181	13	0.51	14.6	10.9	16.9	11.8
25	1	33.9	7.2	1.335	0.284	13	0.51	24.8	17.4	28.8	20.2
32	1 1/4	42.7	6.1	1.743	0.240	13	0.51	42.6	29.8	49.4	34.6
40	1 1/2	48.8	6.6	1.921	0.260	13	0.51	45.2	31.6	52.4	36.7
50	2	61.2	6.2	2.41	0.24	16	0.63	80	65	93	76

Figure 7: FPT



Shut-off valve, type SVA-S and SVA-L

Table 8: FPT inside pipe thread, NPT (ANSI/ASME B 1.20.1)

Size mm	Size in.	Inside pipe thread	k_v -angle m ³ /h	k_v -straight m ³ /h	C_v -angle USgal/min	C_v -straight USgal/min
15	½	(½ × 14 NPT)	8.5	6.0	9.9	7.0
20	¾	(¾ × 14 NPT)	10	7.0	11.6	8.1
25	1	(1 × 11.5 NPT)	32	22.4	37.1	26.0
32	1¼	(1¼ × 11.5 NPT)	36	25.2	41.8	29.3

Figure 8: JIS

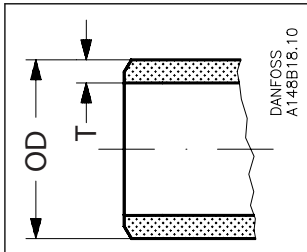

Table 9: Butt-weld JS (G 3454 / 3455 Schedule 80)

Size mm	Size in.	OD mm	T mm	OD in.	T in.	k_v -angle m ³ /h	k_v -straight m ³ /h	C_v -angle USgal/min	C_v -straight USgal/min
15	½	21.3	3.7	0.839	0.146	7	4.9	8.1	5.7
20	¾	26.9	4	1.059	0.158	14.6	10.2	16.9	11.8
25	1	33.7	4.6	1.327	0.181	24.8	17.4	28.8	20.2
32	1¼	42.4	4.9	1.669	0.193	42.6	29.8	49.4	34.6
40	1½	48.3	5.1	1.902	0.201	45.2	31.6	52.4	36.7

Figure 9: JIS

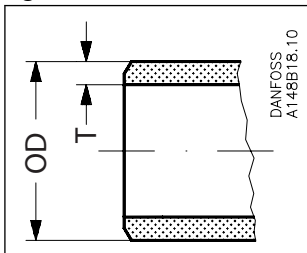
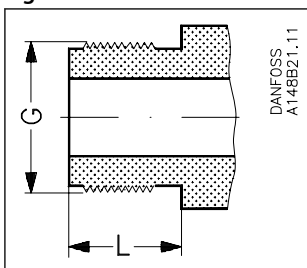

Table 10: Butt-weld JIS (G 3454/3455 Schedule 40)

Size mm	Size in.	OD mm	T mm	OD in.	T in.	k_v -angle m ³ /h	k_v -straight m ³ /h	C_v -angle USgal/min	C_v -straight USgal/min
50	2	60.3	3.9	2.37	0.15	80	65	93	76
65	2½	76.3	5.2	3	0.2	120	97	140	113
80	3	88.9	5.5	3.5	0.22	182	152	211	176
100	4	114.3	6	4.5	0.24	313	278	363	323
125	5	141.3	6.6	5.56	0.26	514	470	596	545
150	6	168.3	7.1	6.63	0.28	785	597	911	693

Connections - SVA 6

Figure 10: T



Shut-off valve, type SVA-S and SVA-L

Table 11: T outside pipe thread, (ISO 228/1)

Size mm	Size in.	Outside pipe thread	L mm	L in.	k_v -angle m ³ /h	k_v -straight m ³ /h	C_v -angle USgal/min	C_v -straight USgal/min
6	¼	G 1/2	16	0.63	2.5	2.0	2.9	2.0

Figure 11: ND

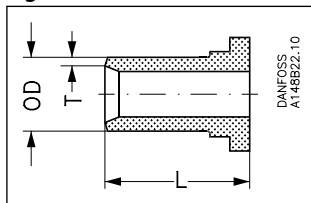

Table 12: Nipples for T outside pipe thread, (ISO 228/1)

Size mm	Size in.	OD mm	T mm	OD in.	T in.	L mm	L in.	Inside pipe thread
6	¼	13.5	2.3	0.531	0.091	60	2.36	G½

Figure 12: NA

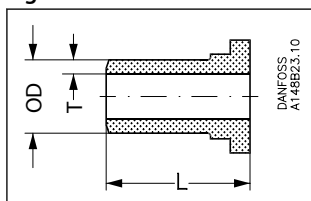

Table 13: NA welding nipples, ANSI (B 36.10 Schedule 80)

Size mm	Size in.	OD mm	T mm	OD in.	T in.	L mm	L in.	Inside pipe thread
6	¼	13.5	3.0	0.531	0.118	60	2.36	G½

Material specification

Figure 13: SVA-S 6-10 and SVA-S 15-20

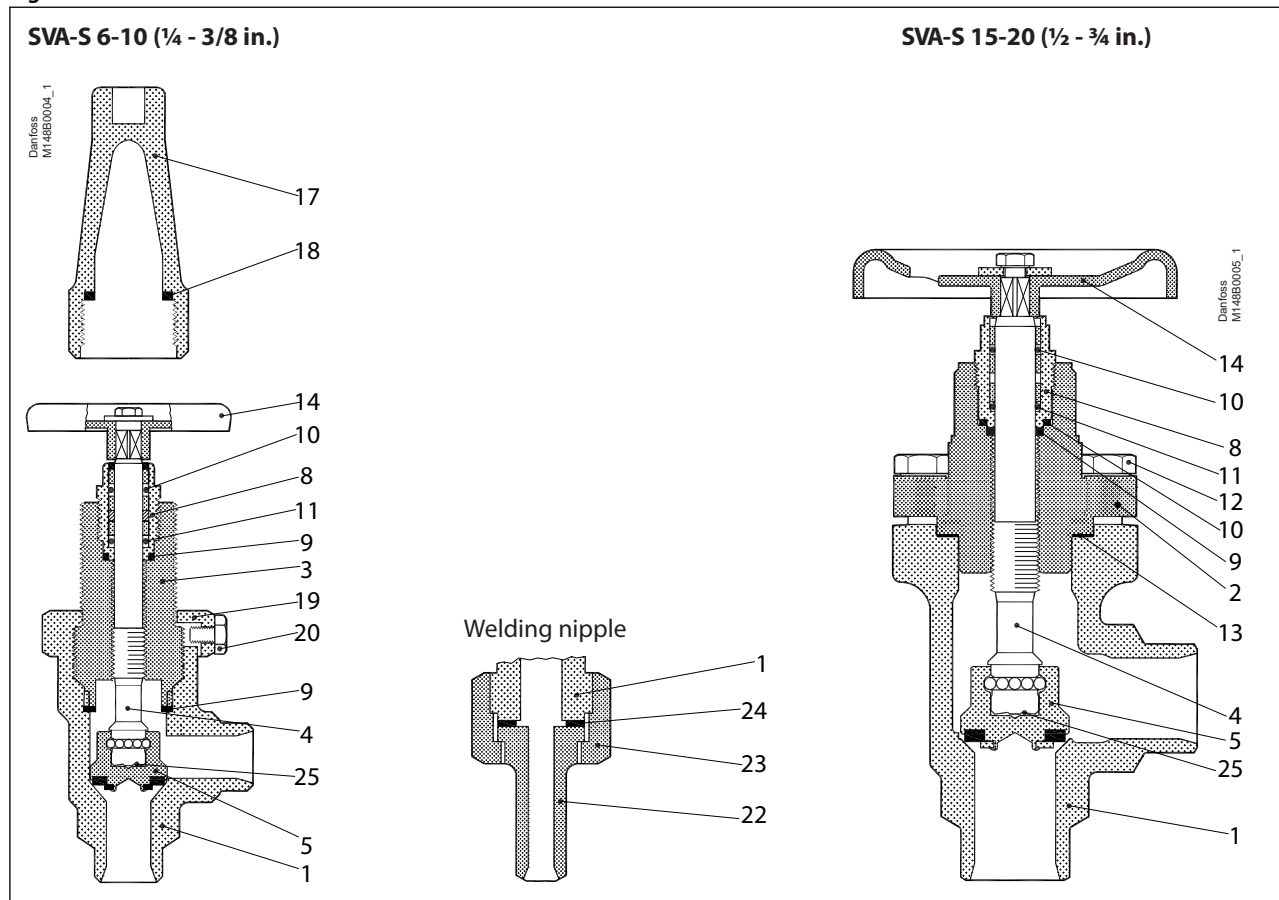

Table 14: Material and parts list

No.	Part	Material	EN	ISO	ASTM
1	Housing	Steel	P285QH+QT, 10222-4		LF2, A350
2	Bonnet	Steel	P285QH+QT, 10222-4		LF2, A350
3	Bonnet, Insert	Steel	11SMn30 10087	Type 2 R 683/9	AISI 1213
4	Spindle	Stainless steel	X8CrNiS18-9 10088	Type 17 683/13	AISI 303
5	Cone	Steel	11SMn30 10087	Type 2 R 683/9	AISI 1213
8	Packing Gland	Stainless steel	X8CrNiS18-9 10088	Type 17 683/13	AISI 303
9	Packing washer	Aluminium			
10	O-ring	Cloroprene (Neoprene)			
11	Spring loaded Teflon ring	PTFE			
12	Bolts	Stainless steel	A2-70	A2-70	Type 308
14	Handwheel	Steel			
17	Cap	Aluminium			
18	Gasket for cap	Nylon			
19	Locking nut	Steel			
20	Screw	Steel			
22	Welding nipple	Steel	S235JRG2 10025	Fe260B, 630	Grade C, A 283
23	Nut	Steel	11SMn30 10087	Type 2 R 683/9	AISI 1213
24	Packing washer	Non-asbestos			
25	Disk spring	Steel			

Shut-off valve, type SVA-S and SVA-L

Figure 14: SVA-S 25-40 (1 - 1½ in.)

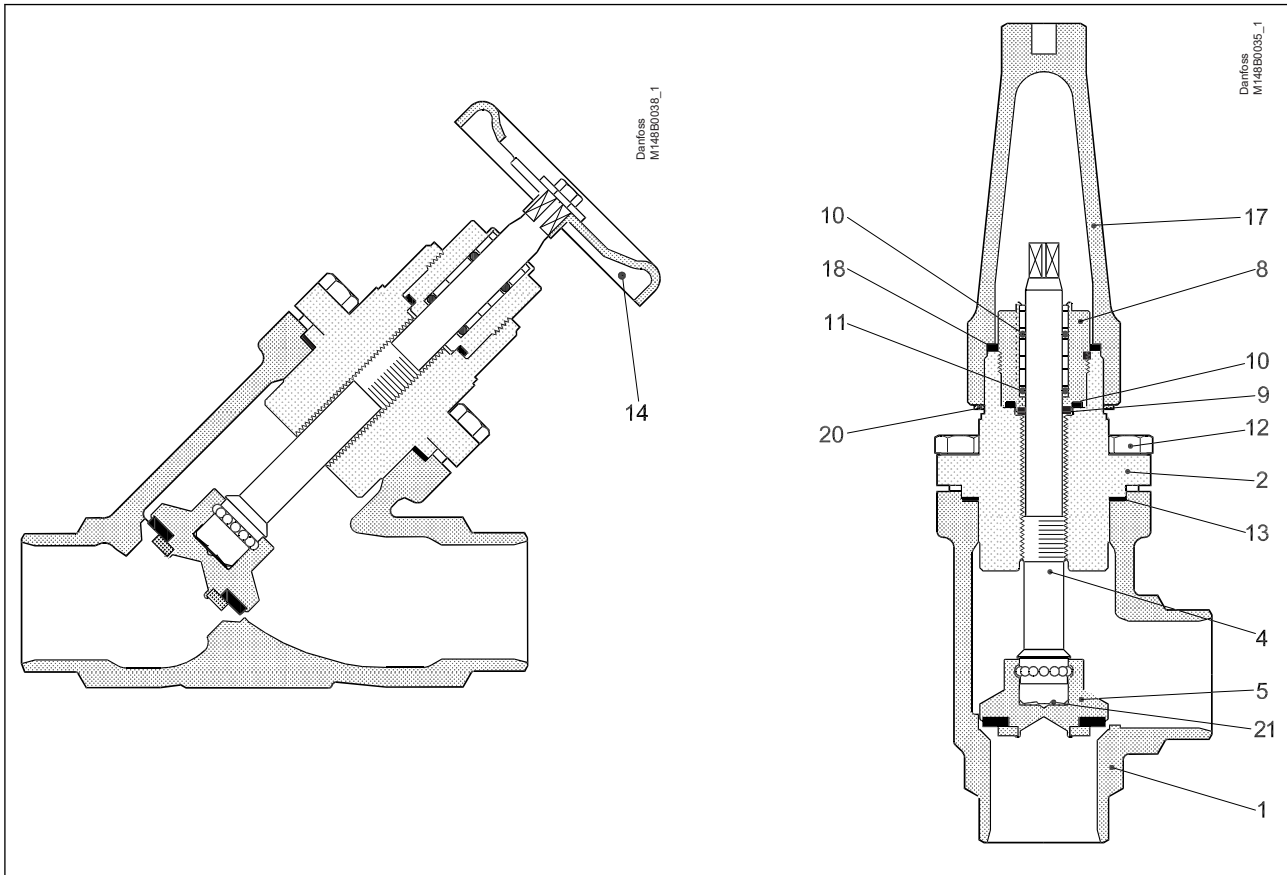

Table 15: Material and parts list

No.	Part	Material	EN	ISO	ASTM
1	Housing	Steel	P285QH+QT, 10222-4		LF2, A350
2	Bonnet	Steel	P285QH+QT, 10222-4		LF2, A350
4	Spindle	Stainless steel	X8CrNiS18-9 10088	Type 17 683/13	AISI 303
5	Cone	Steel	115Mn30 10087	Type 2 R 683/9	AISI 1213
8	Packing Gland	Stainless steel	X8CrNiS18-9 10088	Type 17 683/13	AISI 303
9	Packing washer	Aluminium			
10	O-ring	Cloroprene (Neoprene)			
11	Spring loaded Teflon ring	PTFE			
12	Bolts	Stainless steel	A2-70	A2-70	Type 308
13	Gasket	Fiber, Non-asbestos			
14	Handwheel	Steel			
17	Cap	Aluminium			
18	Gasket for cap	Nylon			
20	Identification ring	Stainless steel			
21	Disk spring	Steel			

Shut-off valve, type SVA-S and SVA-L

Figure 15: SVA-L 15 - 40 (½ - 1½ in.)

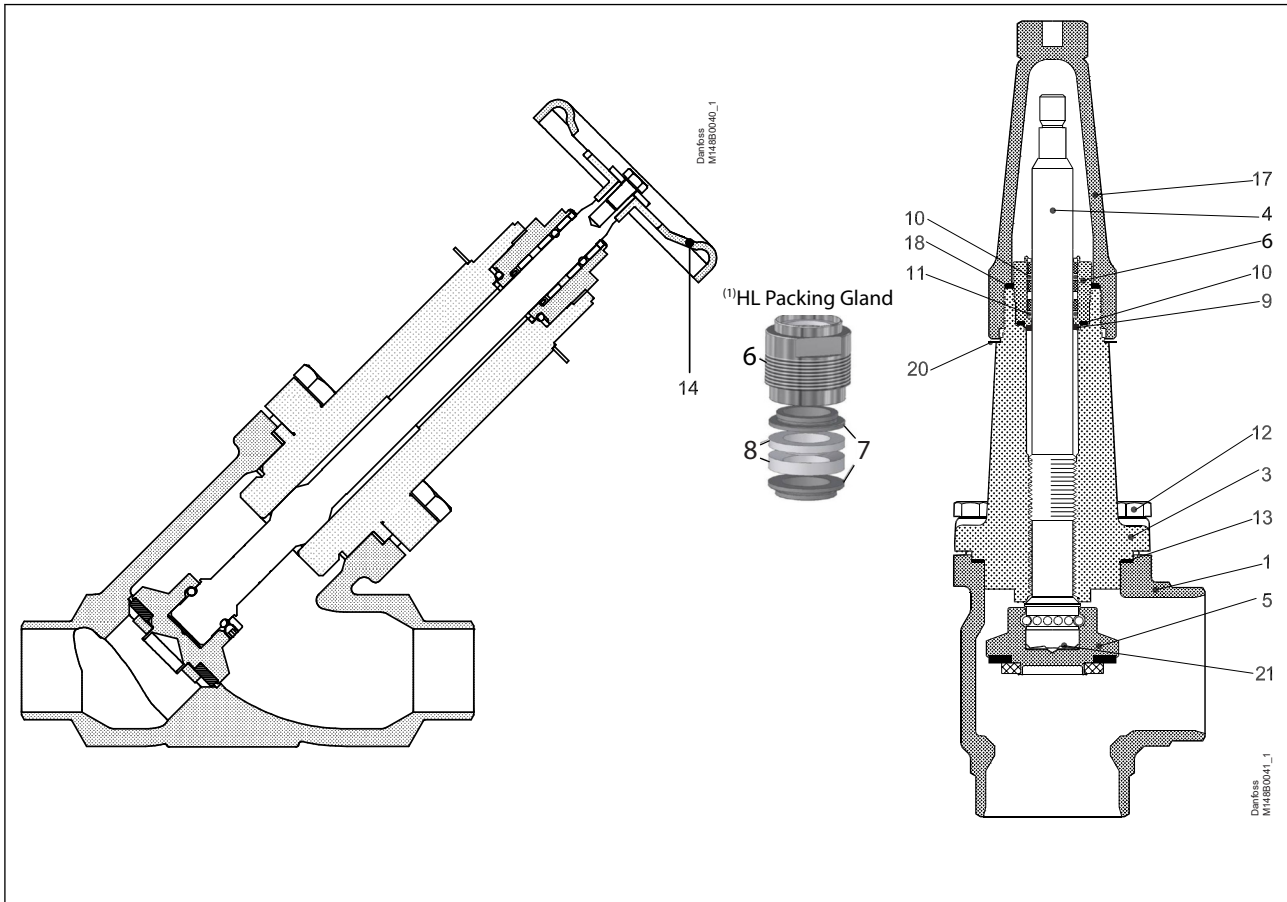

Table 16: Material and parts list

No.	Part	Material	EN	ISO	ASTM
1	Housing	Steel	P285QH+QT, 10222-4		LF2, A350
3	Bonnet	Steel	P285QH+QT, 10222-4		LF2, A350
4	Spindle	Stainless steel	X8CrNiS18-9 10088	Type 17 683/13	AISI 303
5	Cone	Steel	11SMn30 10087	Type 2 R 683/9	AISI 1213
6	Packing Gland	Stainless steel	X8CrNiS18-9 10088	Type 17 683/13	AISI 303
7	Bushing	⁽¹⁾ Cast iron			
8	Gasket	⁽¹⁾ PTFE			
9	Packing washer	Aluminium ⁽¹⁾ None			
10	O-ring	Chloroprene ⁽¹⁾ None			
11	Spring loaded Teflon ring	PTFE ⁽¹⁾ None			
12	Bolts	Stainless steel	A2-70	A2-70	Type 308
13	Gasket	Fiber, Non-asbestos			
14	Hand wheel	Steel			
17	Cap	Aluminium			
18	Gasket for cap	Nylon (PA6)			
20	Identification ring	Stainless steel			
21	Disk spring	Steel			

⁽¹⁾ SVA-HL with HL Packing gland only (see Table 65 and Table 66)

Shut-off valve, type SVA-S and SVA-L

Figure 16: SVA-S 50-65 (2 - 2½ in.)

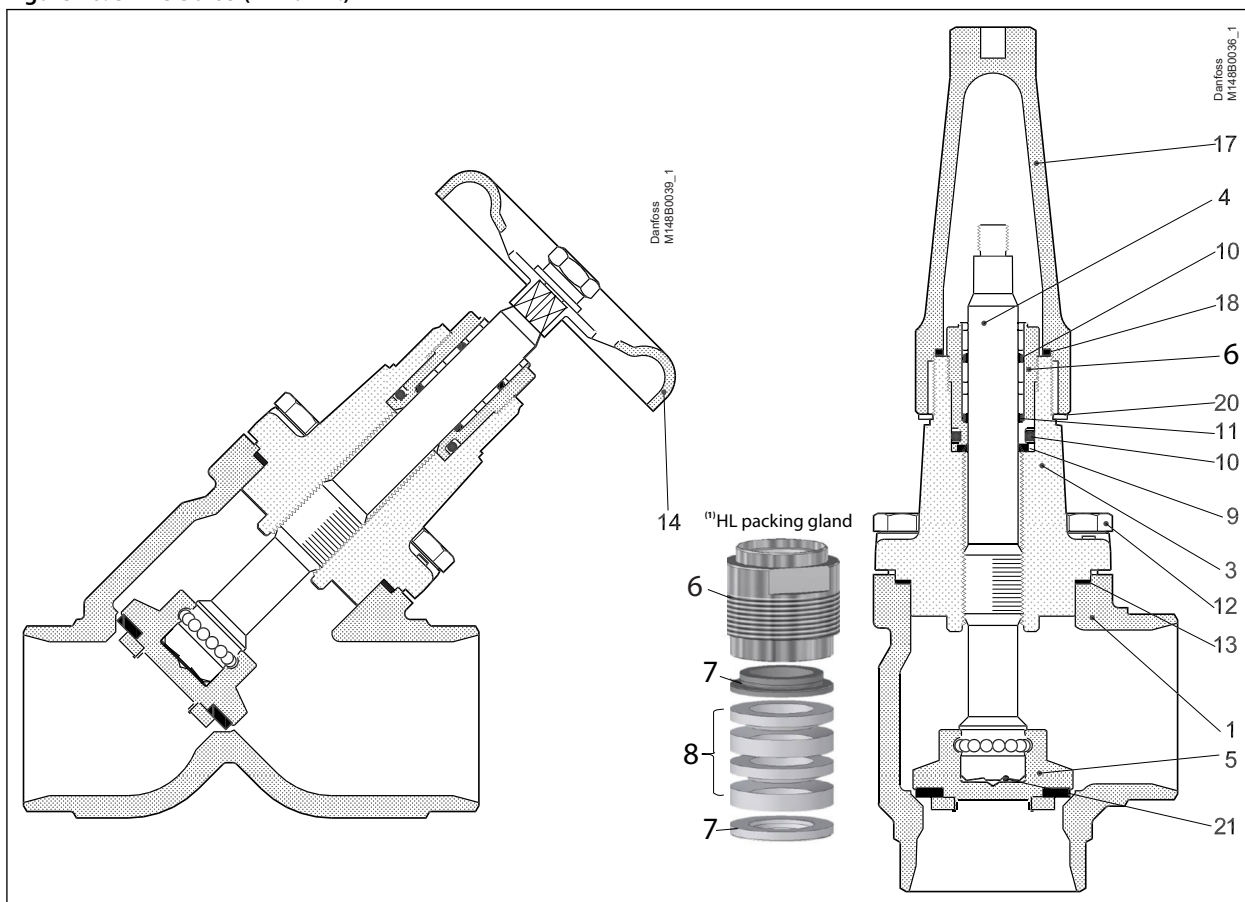

Table 17: Material and parts list

No.	Part	Material	EN	ISO	ASTM
1	Housing	Steel	P285QH+QT, 10222-4		LF2, A350
3	Bonnet	Steel	P285QH+QT, 10222-4		LF2, A350
4	Spindle	Stainless steel	X8CrNiS18-9 10088 DIN 17440 (SVA-SS only)	Type 17 683/13	AISI 303
5	Cone	Steel	11SMn30 10087	Type 2 R 683/9	AISI 1213
6	Packing Gland	Stainless steel	X8CrNiS18-9 10088	Type 17 683/13	AISI 303
7	Bushing + washer	⁽¹⁾ Cast iron			
8	Gasket	⁽¹⁾ PTFE			
9	Packing washer	Aluminium ⁽¹⁾ None			
10	O-ring	Chloroprene ⁽¹⁾ None			
11	Spring loaded Teflon ring	PTFE ⁽¹⁾ None			
12	Bolts	Stainless steel	A2-70	A2-70	Type 308
13	Gasket	Fiber, Non-asbestos			
14	Handwheel	Steel			
17	Cap	Aluminium			
18	Gasket for cap	Nylon			
19	Locking nut	Steel			
20	Identification ring	Stainless steel			
21	Disk spring	Steel			

⁽¹⁾ SVA-HL with HL Packing gland only (see Table 55 and Table 56)

Shut-off valve, type SVA-S and SVA-L

Figure 17: SVA-S 80 - 150 (3 - 6 in.)

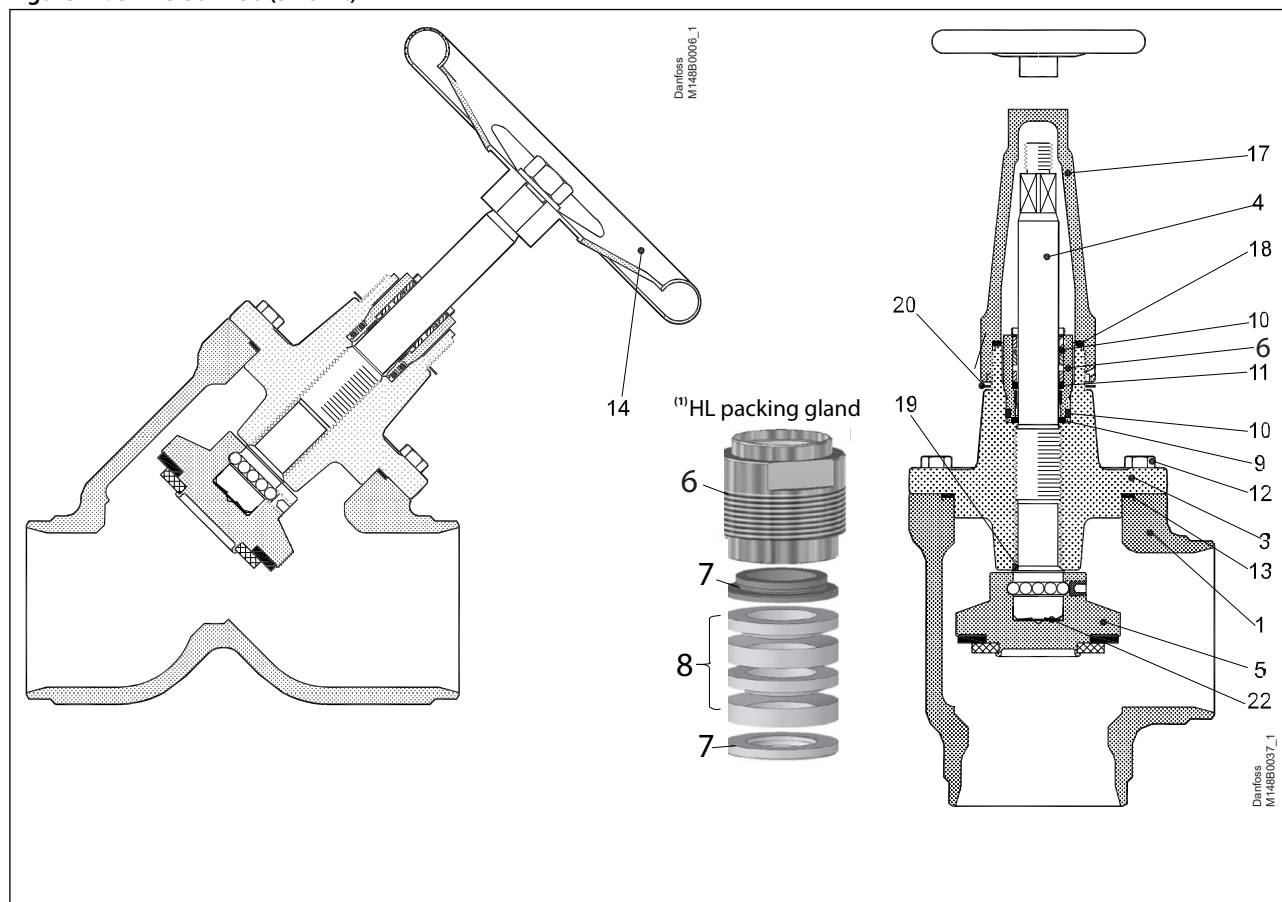

Table 18: Material and parts list

No.	Part	Material	EN	ISO	ASTM
1	Housing	Steel	G20Mn5QT, 10213-3		LCC, A352
3	Bonnet	Steel	P285QH+QT, 10222-4		LF2, A350
4	Spindle	Stainless steel	X5CrNi18-10, 10088	Type 11, R 683/13	AISI 304, A276
5	Cone Cone seal	Steel Teflon (PTFE)	115Mn30, 10087	Type 2, R 683/9	AISI 1213
6	Packing Gland	Stainless steel	X8CrNiS18-9, 10088	Type 17, R 683/13	AISI 303
7	Bushing + Washer	⁽¹⁾ Cast iron			
8	Gasket	⁽¹⁾ PTFE			
9	Packing washer	Aluminium ⁽¹⁾ None			
10	O-ring	Chloroprene ⁽¹⁾ None			
11	Spring loaded Teflon ring	PTFE ⁽¹⁾ None			
12	Bolts	Stainless steel	A2-70	A2-70	Type 308
13	Gasket	Fiber, Non-asbestos			
14	Hand wheel	Steel			
17	Cap	Aluminium			
18	Gasket for cap	Nylon (PA 6)			
19	Soft backseat	Teflon (PTFE)			
20	Identification ring	Stainless steel			
22	Disk spring	Steel			

⁽¹⁾ SVA-HL with HL Packing gland only (see Table 55 and Table 56)

Shut-off valve, type SVA-S and SVA-L

Figure 18: SVA-S 200 (8 in.)

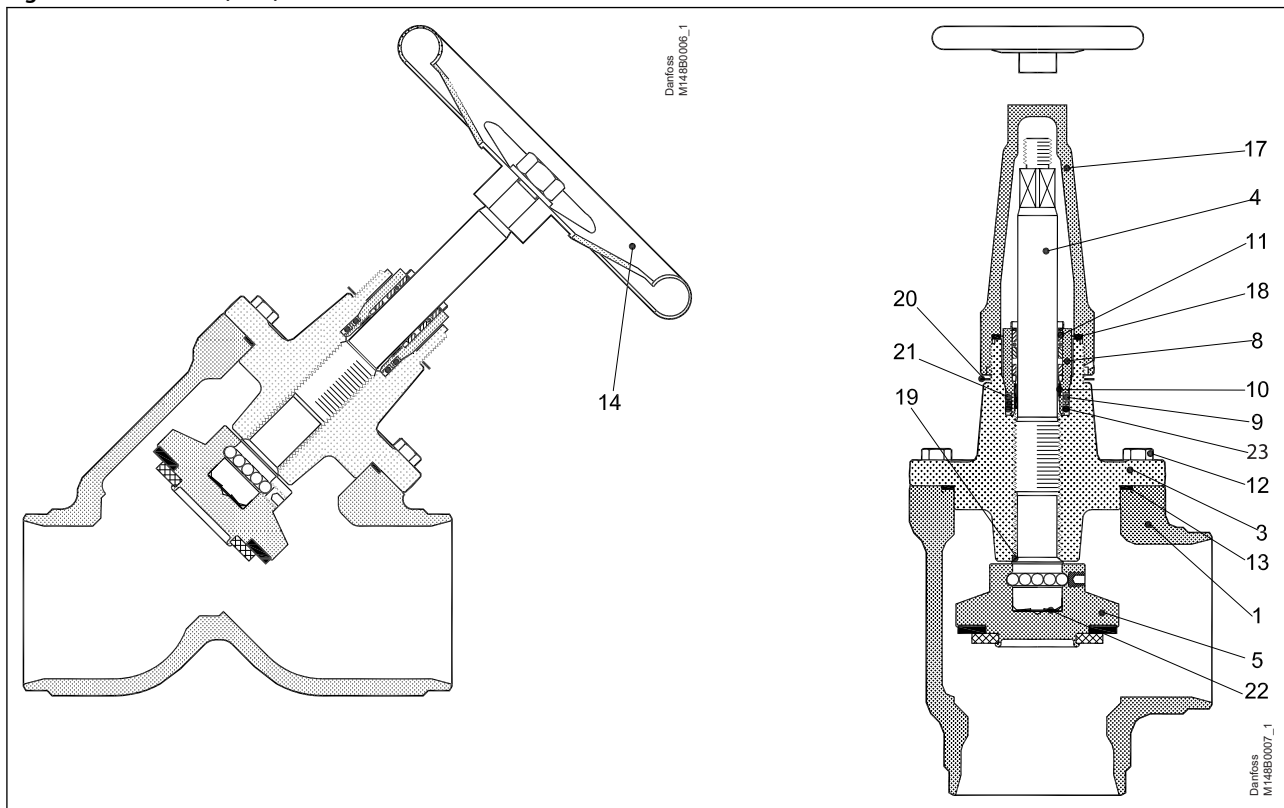

Table 19: Material and parts list

No.	Part	Material	EN	ISO	ASTM
1	Housing	Steel	G20Mn5QT, 10213-3		LCC, A352
3	Bonnet	Steel	P285QH+QT, 10222-4		LF2, A350
4	Spindle	Stainless steel	X5CrNi18-10 10088	Type 11, R 683/13	AISI 304, A276
5	Cone Cone seal	Steel Teflon (PTFE)	11SMn30 10087	Type 2, R 683/9	AISI 1213
8	Packing gland	Stainless steel	X8CrNiS18-9 10088	Type 17 R 683/13	AISI 303
9	O-ring	Cloroprene (Neoprene)			
10	Spring loaded Teflon ring	PTFE			
11	O-ring	Cloroprene (Neoprene)			
12	Bolts	Stainless steel	A2-70	A2-70	Type 308
13	Gasket	Fiber, Non-asbestos			
14	Hand wheel	Steel			
15	Washer	Stainless steel			
16	Nut	Stainless steel			
17	Cap	Aluminium			
18	Gasket for cap	Nylon (PA 6)			
19	Soft backseat	Teflon (PTFE)			
20	Identification ring	Stainless steel			
21	Wear ring	Teflon (PTFE)			
22	Disk spring	Steel			
23	O-ring	PTFE/Cloroprene (Neoprene)			

Dimensions and weights

SVA 6 -10 in angle execution with handwheel

Figure 19: SVA 6 -10 in angle execution with handwheel

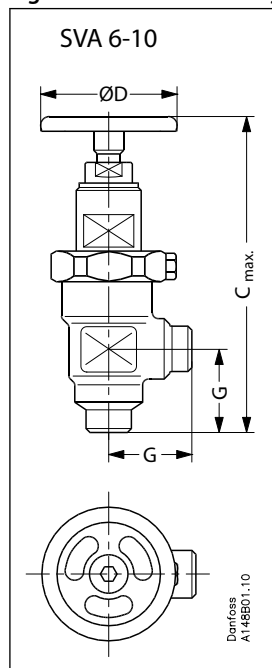

Table 20: SVA 6 -10

Valve size		$C_{max.}$	G	$\varnothing D$	Weight
SVA 6	mm	128	30	50	0.7 kg
	in.	5.04	1.18	1.97	1.54 lb
SVA 10	mm	173	45	60	1.4 kg
	in.	6.81	1.77	2.36	3.08 lb

NOTE:

Specified weights are approximate values only.

SVA 6 - 10 in angle execution with cap

Figure 20: SVA 6 - 10 in angle execution with cap

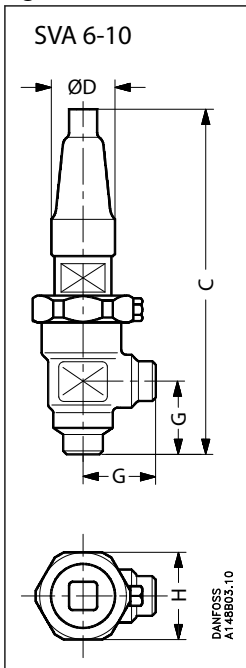

Table 21: SVA 6 - 10

Valve size		C	G	ØD	H	Weight
SVA 6	mm	139	30	30	48	0.8 kg
	in.	5.47	1.18	1.18	1.89	1.76 lb
SVA 10	mm	182	45	38	60	1.4 kg
	in.	7.17	1.77	1.50	2.36	3.08 lb

NOTE:

Specified weights are approximate values only.

SVA 6 - 10 in straight-way execution with handwheel / cap

Figure 21: SVA 6 - 10 with handwheel

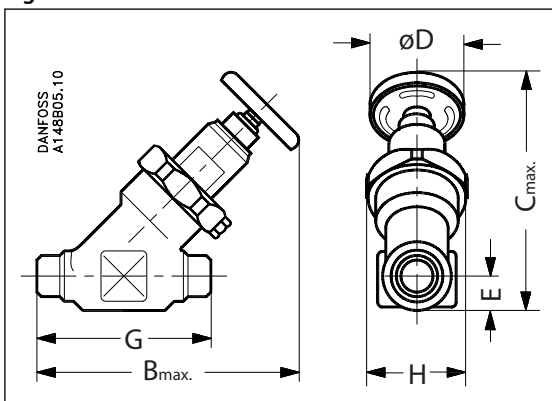

Figure 22: SVA 6 - 10 with cap

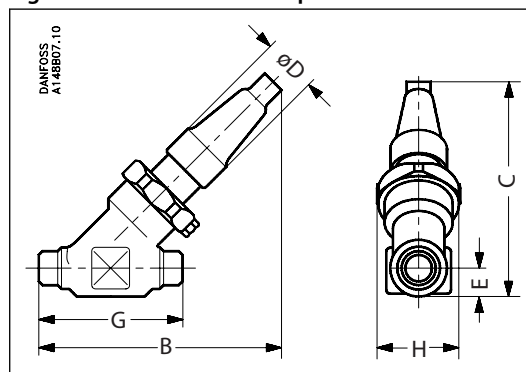

Table 22: SVA 6 - 10 in straight-way execution with handwheel

Valve size		C _{max.}	B _{max.}	E	G	ØD	H	Weight
SVA 6	mm	110	120	13	70	50	48	0.7 kg
	in.	4.33	4.72	0.49	2.76	1.97	1.89	1.54 lb
SVA 10	mm	145	160	20	120	60	60	2.0 kg
	in.	5.71	6.30	0.79	4.72	2.36	2.36	4.4 lb

Shut-off valve, type SVA-S and SVA-L

Table 23: SVA 6 - 10 in straight-way execution with cap

Valve size		C	B	E	G	ØD	H	Weight
SVA 6	mm	110	120	13	70	30	48	0.8 kg
	in.	4.33	4.72	0.49	2.76	1.16	1.89	1.76 lb
SVA 10	mm	145	155	20	120	38	60	2.0 kg
	in.	5.71	6.10	0.79	4.72	1.50	2.36	4.4 lb

NOTE:

Specified weights are approximate values only.

SVA 15 - 40 (½ - 1½ in.) in angleway version with cap / hand wheel

Figure 23: SVA 15 - 40 (½ - 1½ in.) in angleway version with cap / hand wheel

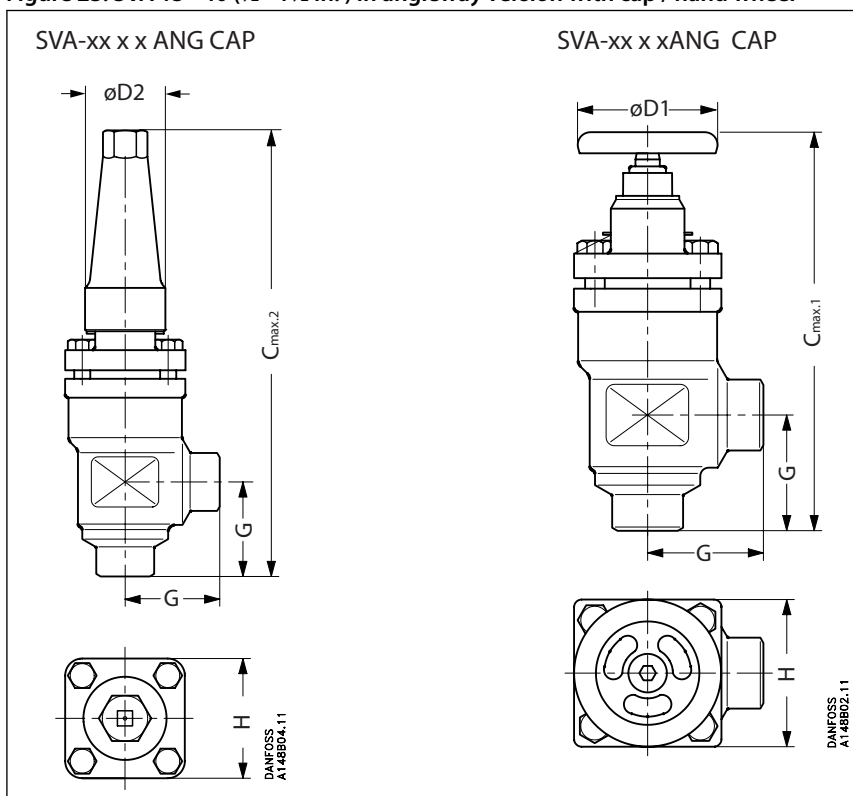

Table 24: SVA-S

Valve size		C _{max.1}	C _{max.2}	G	ØD ₁	ØD ₂	H	Weight
SVA 15 - 20	mm	178	189	45	60	38	60	1.4 kg
	in.	7.00	7.44	1.77	2.36	1.5	2.36	3.1 lb
SVA 25 - 40	mm	234	268	55	80	50	70	2.4 kg
	in.	9.21	10.55	2.17	3.15	1.97	2.76	5.3 lb

Table 25: SVA-S, Socket weld

Valve size		C _{max.1}	C _{max.2}	G	ØD ₁	ØD ₂	H	Weight
SVA 32 - 40	mm	241	275	62	80	50	70	2.9 kg
	in.	9.49	10.83	2.44	3.15	1.97	2.76	6.4 lb

Table 26: SVA-L

Valve size		C _{max.1}	C _{max.2}	G	ØD ₁	ØD ₂	H	Weight
SVA 15 - 20	mm	237	248	45	60	38	60	1.4 kg
	in.	9.33	9.76	1.77	2.36	1.5	2.36	3.1 lb
SVA 25 - 40	mm	296	330	55	80	50	70	2.4 kg
	in.	11.65	12.99	2.17	3.15	1.97	2.76	5.3 lb

Table 27: SVA-L, Socket weld

Valve size		C _{max.1}	C _{max.2}	G	ØD ₁	ØD ₂	H	Weight
SVA 32 - 40	mm	303	337	62	80	50	70	2.9 kg
	in.	11.93	13.27	2.44	3.15	1.97	2.76	6.4 lb

Shut-off valve, type SVA-S and SVA-L

NOTE:

Specified weights are approximate values only.

SVA 15 - 40 (½ - 1½ in.) straightway version with cap / hand wheel

Figure 24: SVA-xx x x STR CAP

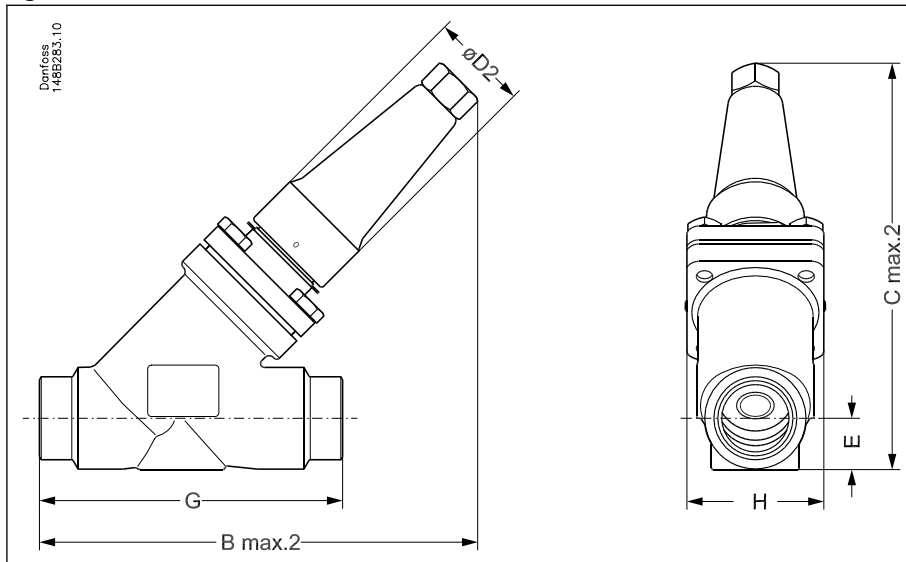

Figure 25: SVA-xx x x STR H-WHEEL

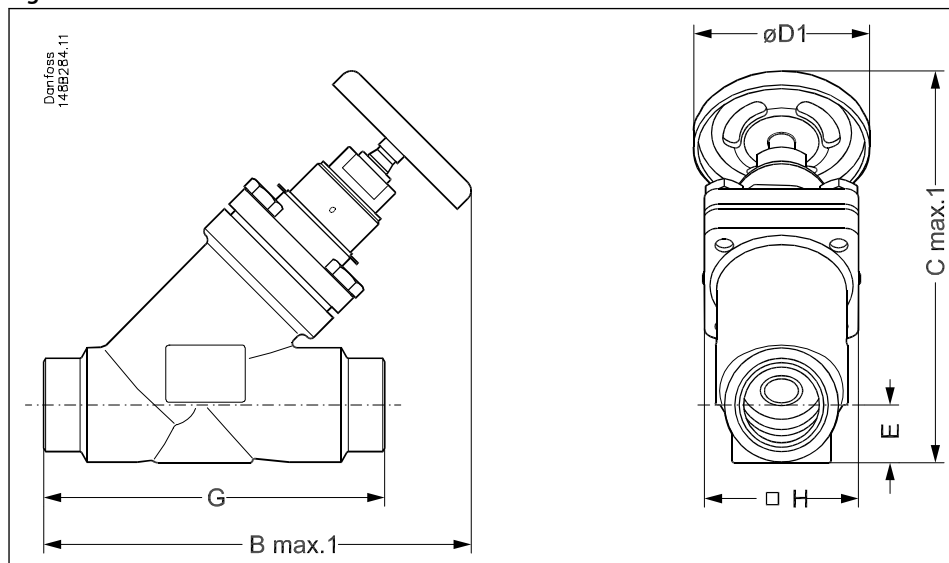

Table 28: SVA-S

Valve size		C _{max.1}	C _{max.2}	B _{max.1}	B _{max.2}	E	G	ØD ₁	ØD ₂	H	Weight
SVA 15 - 20	mm	146	141	160	156	20	120	60	38	60	2.0 kg
SVA (½ - ¾)	in.	5.74	5.55	6.30	6.14	0.79	4.72	2.36	1.5	2.36	4.4 lb
SVA 25 - 40	mm	199	208	212	222	26	155	80	50	70	3.0 kg
SVA (1 - 1½)	in.	7.83	8.19	8.35	8.74	1.02	6.10	3.15	1.97	2.76	6.6 lb

Table 29: SVA-S, Socket weld

Valve size		C _{max.1}	C _{max.2}	B _{max.1}	B _{max.2}	E	G	ØD ₁	ØD ₂	H	Weight
SVA 32	mm	200	209	212	222	27.4	155	80	50	70	3.0 kg
SVA (1¼)	in.	7.87	8.23	8.35	8.74	1.08	6.10	3.15	1.97	2.76	6.6 lb
SVA 40	mm	204	213	212	222	31.0	155	80	50	70	3.0 kg
SVA (1½)	in.	8.03	8.39	8.35	8.74	1.22	6.10	3.15	1.97	2.76	6.6 lb

Shut-off valve, type SVA-S and SVA-L

Table 30: SVA-L

Valve size		C _{max.1}	C _{max.2}	B _{max.1}	B _{max.2}	E	G	ØD ₁	ØD ₂	H	Weight
SVA 15 - 20	mm	188	184	202	198	20	120	60	38	60	2.0 kg
SVA (½ - ¾)	in.	7.40	7.24	7.95	7.80	0.79	4.72	2.36	1.5	2.36	4.4 lb
SVA 25 - 40	mm	243	252	256	265	26	155	80	50	70	3.0 kg
SVA (1 - 1½)	in.	9.57	9.92	10.08	10.43	1.02	6.10	3.15	1.97	2.76	6.6 lb

Table 31: SVA-L, Socket weld

Valve size		C _{max.1}	C _{max.2}	B _{max.1}	B _{max.2}	E	G	ØD ₁	ØD ₂	H	Weight
SVA 32	mm	244	253	256	265	27.4	155	80	50	70	3.0 kg
SVA (1¼)	in.	9.61	9.96	10.08	10.43	1.08	6.10	3.15	1.97	2.76	6.6 lb
SVA 40	mm	248	257	256	265	31.0	155	80	50	70	3.0 kg
SVA (1½)	in.	9.76	10.12	10.08	10.43	1.22	6.10	3.15	1.97	2.76	6.6 lb

NOTE:

Specified weights are approximate values only.

SVA 50 - 65 (2 - 2½ in.) in angleway version with cap / hand wheel

Figure 26: SVA-xx x x ANG CAP

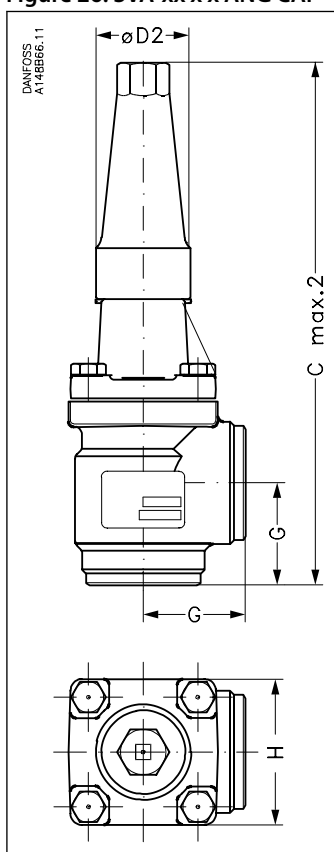

Figure 27: SVA-xx x x ANG H-WHEEL

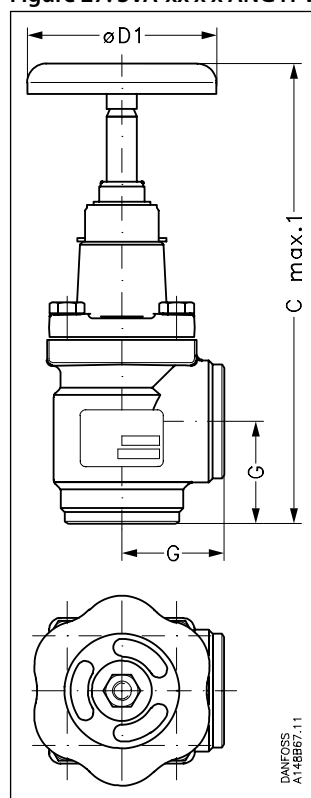

Table 32: SVA-S

Valve size		C _{max.1}	C _{max.2}	G	ØD ₁	ØD ₂	H	Weight
SVA 50	mm	284	315	60	100	50	77	3.2 kg
SVA (2)	in.	11.18	12.40	2.36	3.94	1.97	3.03	7.1 lb
SVA 65	mm	310	335	70	100	50	90	4.8 kg
SVA (2½)	in.	12.20	13.19	2.76	3.94	1.97	3.54	10.6 lb

Table 33: SVA-S, Socket weld

Valve size		C _{max.1}	C _{max.2}	G	ØD ₁	ØD ₂	H	Weight
SVA 50	mm	289	320	65	100	50	77	4.1 kg
SVA (2)	in.	11.38	12.60	2.56	3.94	1.97	3.03	9.0 lb

NOTE:

Specified weights are approximate values only.

SVA 50 - 65 (2 - 2½ in.) in straightway version with cap / hand wheel

Figure 28: SVA-xx x x STR CAP

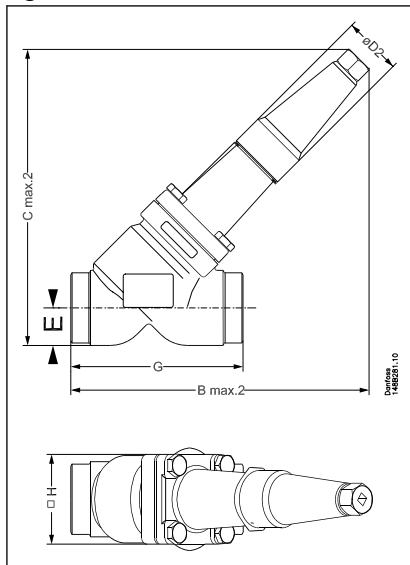

Figure 29: SVA-xx x x STR H-WHEEL

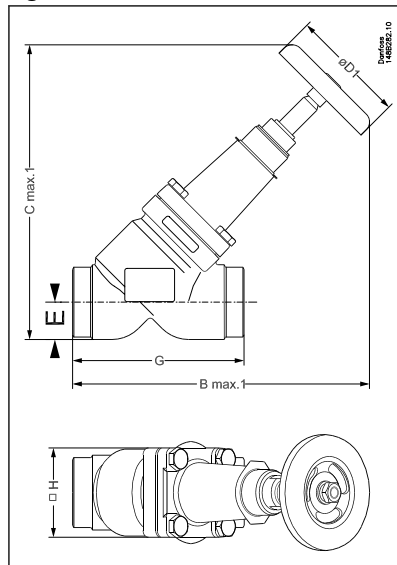

Table 34: SVA-S

Valve size		B _{max.1}	B _{max.2}	C _{max.1}	C _{max.2}	E	G	ØD ₁	ØD ₂	H	Weight
SVA 50	mm	259	259	257	257	32	148	100	50	77	4.2 kg
SVA (2)	in.	10.20	10.20	10.12	10.12	1.26	5.83	3.94	1.97	3.03	9.3 lb
SVA 65	mm	284	280	284	280	40	176	100	50	90	6.3 kg
SVA (2½)	in.	11.18	11.02	11.18	11.02	1.57	6.93	3.94	1.97	3.54	13.9 lb

Table 35: SVA-S, Socket weld

Valve size		B _{max.1}	B _{max.2}	C _{max.1}	C _{max.2}	E	G	ØD ₁	ØD ₂	H	Weight
SVA 50	mm	266	266	261	261	37	162	100	50	77	5.1 kg
SVA (2)	in.	10.47	10.47	10.28	10.28	1.26	6.38	3.94	1.97	3.03	11.2 lb

NOTE:

Specified weights are approximate values only.

SVA 80 - 200 (3 - 8 in.) angleway version with cap / hand wheel

Figure 30: SVA-xx x x ANG CAP Figure 31: SVA-xx x x ANG H-WHEEL

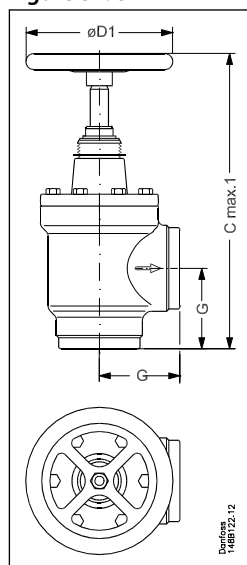
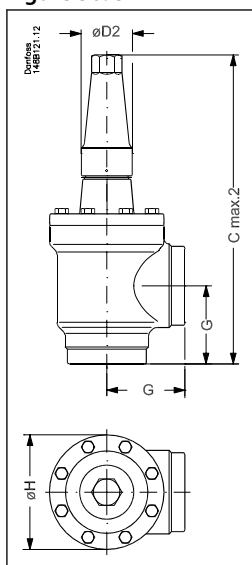

Shut-off valve, type SVA-S and SVA-L

Table 36: SVA-S

Valve size		$C_{max.1}$	$C_{max.2}$	G	$\varnothing D_1$	$\varnothing D_2$	$\varnothing H$	Weight
SVA 80	mm	373	388	90	200	58	129	9.7 kg
SVA (3)	in.	14.69	15.28	3.54	7.87	2.28	5.08	21.4 lb
SVA 100	mm	432	437	106	250	58	156	15.3 kg
SVA (4)	in.	17.00	17.20	4.17	9.84	2.28	6.14	33.7 lb
SVA 125	mm	517	533	128	315	74	193	28.1 kg
SVA (5)	in.	20.35	20.98	5.04	12.40	2.91	7.60	61.9 lb
SVA 150	mm	564	568	145	315	74	219	39.7 kg
SVA (6)	in.	22.20	22.36	5.71	12.40	2.91	8.62	87.5 lb
SVA 200	mm	677	678	180	400	86	276	79.5 kg
SVA (8)	in.	26.63	26.69	7.09	15.75	3.39	10.87	175.3 lb

NOTE:

Specified weights are approximate values only.

SVA 80 - 200 (3 - 8 in.) straightway version with cap / hand wheel

Figure 32: SVA-xx x x STR CAP

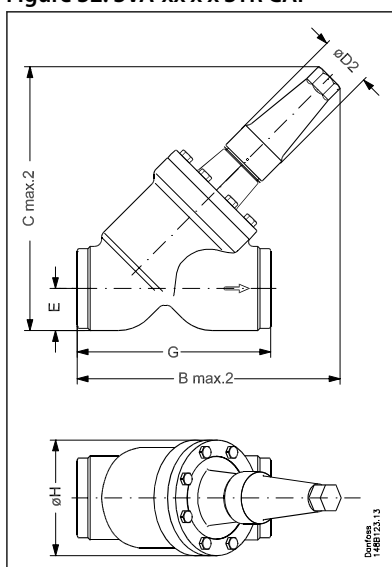

Figure 33: SVA-xx x x STR H-WHEEL

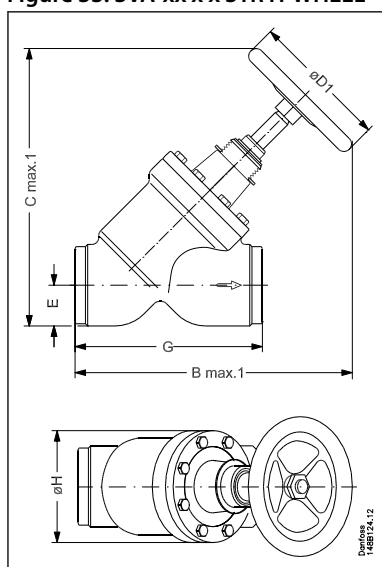

Table 37: SVA-S

Valve size		$B_{max.1}$	$B_{max.2}$	$C_{max.1}$	$C_{max.2}$	E	G	$\varnothing D_1$	$\varnothing D_2$	$\varnothing H$	Weight
SVA 80	mm	365	321	367	322	48	216	200	58	129	10.9 kg
SVA (3)	in.	14.37	12.64	14.45	12.72	1.89	8.50	7.87	2.28	5.08	24.0 lb
SVA 100	mm	435	367	443	375	60	264	250	58	156	18.2 kg
SVA (4)	in.	17.13	14.45	17.44	14.76	2.36	10.39	9.84	2.28	6.14	40.1 lb
SVA 125	mm	526	444	538	456	74	322	315	74	193	32.8 kg
SVA (5)	in.	20.71	17.48	21.18	17.95	2.91	12.68	12.40	2.91	7.60	72.3 lb
SVA 150	mm	572	483	594	505	91	370	315	74	219	60.0 kg
SVA (6)	in.	22.52	19.02	23.39	19.88	3.58	14.57	12.40	2.91	8.62	132.3 lb
SVA 200	mm	692	579	726	613	117	464	400	86	276	111.5 kg
SVA (8)	in.	27.24	22.80	28.58	24.13	4.61	18.27	15.75	3.39	10.87	245.8 lb

NOTE:

Specified weights are approximate values only.

Ordering

Available connection sizes

SVA-S:

The **S** means Standard bonnet length (sizes from DN50 to DN200 are insulation friendly)

SVA-L:

The **L** means Long bonnet length (insulation friendly)

NOTE:

HL from SVA-HL means HL packing gland. SVA-HL 15-40 with the same bonnet length as SVA-L, SVA-HL 50-150 with the same bonnet length as SVA-S.

Table 38: Connection sizes

Size	SVA-S	SVA-L
6	x	
10	x	
15	x	x
20	x	x
25	x	x
32	x	x
40	x	x
50	x	
65	x	
80	x	
100	x	
125	x	
150	x	
200	x	

Please note that the type codes only serve to identify the valves, some of which may not form part of the standard product range. For further information please contact your local Danfoss Sales Company.

Table 39: Type codes

Valve type	SVA	Shut-off valve							
		Available connections							
Nominal size in mm (valve size measured on the connection diameter)		A/D	G	SOC		FPT	T	JIS	
	6	DN 6 (¼)	x					x	
	10	DN 10 (¾)	x	x					
	15	DN 15 (½)	x	x	x		x		x
	20	DN 20 (¾)	x	x	x	x ⁽¹⁾	x		x
	25	DN 25 (1)	x	x	x		x		x
	32	DN 32 (1¼)	x	x	x		x		x
	40	DN 40 (1½)	x	x	x				x
	50	DN 50 (2)	x	x	x				x
	65	DN 65 (2½)	x						x
	80	DN 80 (3)	x						x
	100	DN 100 (4)	x	x					x
	125	DN 125 (5)	x	x					x
	150	DN 150 (6)	x	x					x
200	DN 200 (8)	x							

Shut-off valve, type SVA-S and SVA-L

Valve type	SVA	Shut-off valve
Connections	A	Butt-weld ANSI (B 36.10 Schedule 80), DN 6 - 40 (¼ - 1½ in.) Butt-weld ANSI (B 36.10 Schedule 40), DN 50 - 200 (2 - 8 in.)
	D	Butt-weld connection: DIN EN 10220
	G	Butt-weld connection: GOST (8734-75 and 8732-78)
	SOC	Socket weld: ANSI B 16.11
	FPT	Female Pipe Thread NPT: ANSI/ASME B 1.20.1
	T	Outside threaded connections ISO 228/1 Pipe thread
	JIS	Butt-weld JIS (G 3454/3455 Schedule 80), DN 15 - 40 (½ - 1½ in.) Butt-weld JIS (G 3454/3455 Schedule 40), DN 50 - 150 (2 - 6 in.)
Valve housing	ANG STR	Angle flow Straight flow
Other equipment	H-WHEEL CAP	Hand wheel Cap

⁽¹⁾ Special combination SOC-inlet, FPT outlet

❗ IMPORTANT:

Where products need to be certified according to specific certification societies or where higher pressures are required, the relevant information should be included at the time of order.

Ordering SVA-S complete valves

Example:

SVA-S 20 DIN angleway with hand wheel = 148B5300

❗ IMPORTANT:

Where products need to be certified according to specific certification societies or where higher pressures are required, the relevant information should be included at the time of order.

Table 40: SVA-S Angleway - Butt-weld DIN (EN 10220)

Size		Type	MWP		Code number
mm	in.		bar	psi	
6	¼	SVA-S 6 D ANG H-WHEEL	52	754	148B5000
6	¼	SVA-S 6 D ANG CAP	52	754	148B5001
10	¾	SVA-S 10 D ANG H-WHEEL	52	754	148B5100
10	¾	SVA-S 10 D ANG CAP	52	754	148B5101
15	½	SVA-S 15 D ANG H-WHEEL	52	754	148B5200
15	½	SVA-S 15 D ANG CAP	52	754	148B5201
20	¾	SVA-S 20 D ANG H-WHEEL	52	754	148B5300
20	¾	SVA-S 20 D ANG CAP	52	754	148B5301
25	1	SVA-S 25 D ANG H-WHEEL	52	754	148B5400
25	1	SVA-S 25 D ANG CAP	52	754	148B5401
32	1¼	SVA-S 32 D ANG H-WHEEL	52	754	148B5500
32	1¼	SVA-S 32 D ANG CAP	52	754	148B5501
40	1½	SVA-S 40 D ANG H-WHEEL	52	754	148B5600
40	1½	SVA-S 40 D ANG CAP	52	754	148B5601
50	2	SVA-S 50 D ANG H-WHEEL	52	754	148B5700
50	2	SVA-S 50 D ANG CAP	52	754	148B5701
65	2½	SVA-S 65 D ANG H-WHEEL	52	754	148B5800
65	2½	SVA-S 65 D ANG CAP	52	754	148B5801
80	3	SVA-S 80 D ANG H-WHEEL	52	754	148B5900
80	3	SVA-S 80 D ANG CAP	52	754	148B5901
100	4	SVA-S 100 D ANG H-WHEEL	52	754	148B6000
100	4	SVA-S 100 D ANG CAP	52	754	148B6001
125	5	SVA-S 125 D ANG H-WHEEL	52	754	148B6100
125	5	SVA-S 125 D ANG CAP	52	754	148B6101
150	6	SVA-S 150 D ANG H-WHEEL	52	754	148B6200
150	6	SVA-S 150 D ANG CAP	52	754	148B6201
200	8	SVA-S 200 D ANG H-WHEEL	52	754	148B6300
200	8	SVA-S 200 D ANG CAP	52	754	148B6301

Shut-off valve, type SVA-S and SVA-L

Table 41: SVA-S Straightway - Butt-weld DIN (EN 10220)

Size		Type	MWP		Code number
mm	in.		bar	psi	
6	¼	SVA-S 6 D STR H-WHEEL	52	754	14885010
6	¼	SVA-S 6 D STR CAP	52	754	14885011
10	⅜	SVA-S 10 D STR H-WHEEL	52	754	14885110
10	⅜	SVA-S 10 D STR CAP	52	754	14885111
15	½	SVA-S 15 D STR H-WHEEL	52	754	14885210
15	½	SVA-S 15 D STR CAP	52	754	14885211
20	¾	SVA-S 20 D STR H-WHEEL	52	754	14885310
20	¾	SVA-S 20 D STR CAP	52	754	14885311
25	1	SVA-S 25 D STR H-WHEEL	52	754	14885410
25	1	SVA-S 25 D STR CAP	52	754	14885411
32	1¼	SVA-S 32 D STR H-WHEEL	52	754	14885510
32	1¼	SVA-S 32 D STR CAP	52	754	14885511
40	1½	SVA-S 40 D STR H-WHEEL	52	754	14885610
40	1½	SVA-S 40 D STR CAP	52	754	14885611
50	2	SVA-S 50 D STR H-WHEEL	52	754	14885710
50	2	SVA-S 50 D STR CAP	52	754	14885711
65	2½	SVA-S 65 D STR H-WHEEL	52	754	14885810
65	2½	SVA-S 65 D STR CAP	52	754	14885811
80	3	SVA-S 80 D STR H-WHEEL	52	754	14885910
80	3	SVA-S 80 D STR CAP	52	754	14885911
100	4	SVA-S 100 D STR H-WHEEL	52	754	14886010
100	4	SVA-S 100 D STR CAP	52	754	14886011
125	5	SVA-S 125 D STR H-WHEEL	52	754	14886110
125	5	SVA-S 125 D STR CAP	52	754	14886111
150	6	SVA-S 150 D STR H-WHEEL	52	754	14886210
150	6	SVA-S 150 D STR CAP	52	754	14886211
200	8	SVA-S 200 D STR H-WHEEL	52	754	14886310
200	8	SVA-S 200 D STR CAP	52	754	14886311

Table 42: SVA-S Angleway - Butt-weld ANSI (B 36.10 Schedule 80)

Size		Type	MWP		Code number
mm	in.		bar	psi	
6	¼	SVA-S 6 A ANG H-WHEEL	52	754	14885020
6	¼	SVA-S 6 A ANG CAP	52	754	14885021
10	⅜	SVA-S 10 A ANG H-WHEEL	52	754	14885120
10	⅜	SVA-S 10 A ANG CAP	52	754	14885121
15	½	SVA-S 15 A ANG H-WHEEL	52	754	14885220
15	½	SVA-S 15 A ANG CAP	52	754	14885221
20	¾	SVA-S 20 A ANG H-WHEEL	52	754	14885320
20	¾	SVA-S 20 A ANG CAP	52	754	14885321
25	1	SVA-S 25 A ANG H-WHEEL	52	754	14885420
25	1	SVA-S 25 A ANG CAP	52	754	14885421
32	1¼	SVA-S 32 A ANG H-WHEEL	52	754	14885520
32	1¼	SVA-S 32 A ANG CAP	52	754	14885521
40	1½	SVA-S 40 A ANG H-WHEEL	52	754	14885620
40	1½	SVA-S 40 A ANG CAP	52	754	14885621

Table 43: SVA-S Straightway - Butt-weld ANSI (B 36.10 Schedule 80)

Size		Type	MWP		Code number
mm	in.		bar	psi	
6	¼	SVA-S 6 A STR H-WHEEL	52	754	14885030
6	¼	SVA-S 6 A STR CAP	52	754	14885031
10	⅜	SVA-S 10 A STR H-WHEEL	52	754	14885130
10	⅜	SVA-S 10 A STR CAP	52	754	14885131
15	½	SVA-S 15 A STR H-WHEEL	52	754	14885230
15	½	SVA-S 15 A STR CAP	52	754	14885231

Shut-off valve, type SVA-S and SVA-L

Size		Type	MWP		Code number
mm	in.		bar	psi	
20	¾	SVA-S 20 A STR H-WHEEL	52	754	148B5330
20	¾	SVA-S 20 A STR CAP	52	754	148B5331
25	1	SVA-S 25 A STR H-WHEEL	52	754	148B5430
25	1	SVA-S 25 A STR CAP	52	754	148B5431
32	1¼	SVA-S 32 A STR H-WHEEL	52	754	148B5530
32	1¼	SVA-S 32 A STR CAP	52	754	148B5531
40	1½	SVA-S 40 A STR H-WHEEL	52	754	148B5630
40	1½	SVA-S 40 A STR CAP	52	754	148B5631

Table 44: SVA-S Angleway - Butt-weld ANSI (B 36.10 Schedule 40)

Size		Type	MWP		Code number
mm	in.		bar	psi	
50	2	SVA-S 50 A ANG H-WHEEL	52	754	148B5720
50	2	SVA-S 50 A ANG CAP	52	754	148B5721
65	2½	SVA-S 65 A ANG H-WHEEL	52	754	148B5820
65	2½	SVA-S 65 A ANG CAP	52	754	148B5821
80	3	SVA-S 80 A ANG H-WHEEL	52	754	148B5920
80	3	SVA-S 80 A ANG CAP	52	754	148B5921
100	4	SVA-S 100 A ANG H-WHEEL	52	754	148B6020
100	4	SVA-S 100 A ANG CAP	52	754	148B6021
125	5	SVA-S 125 A ANG H-WHEEL	52	754	148B6120
125	5	SVA-S 125 A ANG CAP	52	754	148B6121
150	6	SVA-S 150 A ANG H-WHEEL	52	754	148B6220
150	6	SVA-S 150 A ANG CAP	52	754	148B6221
200	8	SVA-S 200 A ANG H-WHEEL	52	754	148B6320
200	8	SVA-S 200 A ANG CAP	52	754	148B6321

Table 45: SVA-S Straightway - Butt-weld ANSI (B 36.10 Schedule 40)

Size		Type	MWP		Code number
mm	in.		bar	psi	
50	2	SVA-S 50 A STR H-WHEEL	52	754	148B5730
50	2	SVA-S 50 A STR CAP	52	754	148B5731
65	2½	SVA-S 65 A STR H-WHEEL	52	754	148B5830
65	2½	SVA-S 65 A STR CAP	52	754	148B5831
80	3	SVA-S 80 A STR H-WHEEL	52	754	148B5930
80	3	SVA-S 80 A STR CAP	52	754	148B5931
100	4	SVA-S 100 A STR H-WHEEL	52	754	148B6030
100	4	SVA-S 100 A STR CAP	52	754	148B6031
125	5	SVA-S 125 A STR H-WHEEL	52	754	148B6130
125	5	SVA-S 125 A STR CAP	52	754	148B6131
150	6	SVA-S 150 A STR H-WHEEL	52	754	148B6230
150	6	SVA-S 150 A STR CAP	52	754	148B6231
200	8	SVA-S 200 A STR H-WHEEL	52	754	148B6330
200	8	SVA-S 200 A STR CAP	52	754	148B6331

Table 46: SVA-S Angleway - Butt-weld, GOST

Size		Type	MWP		Code number
mm	in.		bar	psi	
150	6	SVA-S 150 G ANG H-WHEEL	52	754	148B6240
150	6	SVA-S 150 G ANG CAP	52	754	148B6241

Table 47: SVA-S Straightway - Butt-weld, GOST

Size		Type	MWP		Code number
mm	in.		bar	psi	
150	6	SVA-S 150 G STR H-WHEEL	52	754	148B6250
150	6	SVA-S 150 G STR CAP	52	754	148B6251

Shut-off valve, type SVA-S and SVA-L

Table 48: SVA-S Angleway - Socket welding ANSI (B 16.11)

Size		Type	MWP		Code number
mm	in.		bar	psi	
15	½	SVA-S 15 SOC ANG H-WHEEL	52	754	14885222
15	½	SVA-S 15 SOC ANG CAP	52	754	14885223
20	¾	SVA-S 20 SOC ANG H-WHEEL	52	754	14885322
20	¾	SVA-S 20 SOC ANG CAP	52	754	14885323
25	1	SVA-S 25 SOC ANG H-WHEEL	52	754	14885422
25	1	SVA-S 25 SOC ANG CAP	52	754	14885423
32	1¼	SVA-S 32 SOC ANG H-WHEEL	52	754	14885522
32	1¼	SVA-S 32 SOC ANG CAP	52	754	14885523
40	1½	SVA-S 40 SOC ANG H-WHEEL	52	754	14885622
40	1½	SVA-S 40 SOC ANG CAP	52	754	14885623
50	2	SVA-S 50 SOC ANG H-WHEEL	52	754	14885722
50	2	SVA-S 50 SOC ANG CAP	52	754	14885723

Table 49: SVA-S Straightway - Socket welding ANSI (B 16.11)

Size		Type	MWP		Code number
mm	in.		bar	psi	
15	½	SVA-S 15 SOC STR H-WHEEL	52	754	14885232
15	½	SVA-S 15 SOC STR CAP	52	754	14885233
20	¾	SVA-S 20 SOC STR H-WHEEL	52	754	14885332
20	¾	SVA-S 20 SOC STR CAP	52	754	14885333
25	1	SVA-S 25 SOC STR H-WHEEL	52	754	14885432
25	1	SVA-S 25 SOC STR CAP	52	754	14885433
32	1¼	SVA-S 32 SOC STR H-WHEEL	52	754	14885532
32	1¼	SVA-S 32 SOC STR CAP	52	754	14885533
40	1½	SVA-S 40 SOC STR H-WHEEL	52	754	14885632
40	1½	SVA-S 40 SOC STR CAP	52	754	14885633
50	2	SVA-S 50 SOC STR H-WHEEL	52	754	14885732
50	2	SVA-S 50 SOC STR CAP	52	754	14885733

Table 50: SVA-S Angleway - FPT inside pipe thread, NPT (ANSI/ASME B 1.20.1)

Size		Type	MWP		Code number
mm	in.		bar	psi	
15	½	SVA-S 15 FPT ANG H-WHEEL	52	754	14885224
15	½	SVA-S 15 FPT ANG CAP	52	754	14885225
20	¾	SVA-S 20 FPT ANG H-WHEEL	52	754	14885324
20	¾	SVA-S 20 FPT ANG CAP	52	754	14885325
25	1	SVA-S 25 FPT ANG H-WHEEL	52	754	14885424
25	1	SVA-S 25 FPT ANG CAP	52	754	14885425
32	1¼	SVA-S 32 FPT ANG H-WHEEL	52	754	14885524
32	1¼	SVA-S 32 FPT ANG CAP	52	754	14885525

Table 51: SVA-S Straightway - FPT inside pipe thread, NPT (ANSI/ASME B 1.20.1)

Size		Type	MWP		Code number
mm	in.		bar	psi	
15	½	SVA-S 15 FPT STR H-WHEEL	52	754	14885234
15	½	SVA-S 15 FPT STR CAP	52	754	14885235
20	¾	SVA-S 20 FPT STR H-WHEEL	52	754	14885334
20	¾	SVA-S 20 FPT STR CAP	52	754	14885335
25	1	SVA-S 25 FPT STR H-WHEEL	52	754	14885434
25	1	SVA-S 25 FPT STR CAP	52	754	14885435
32	1¼	SVA-S 32 FPT STR H-WHEEL	52	754	14885534
32	1¼	SVA-S 32 FPT STR CAP	52	754	14885535

Table 52: SVA-S Angleway - T outside pipe thread, (ISO 228/1)

Size		Type	MWP		Code number
mm	in.		bar	psi	
6	¼	SVA-S 6 T ANG CAP	52	754	14885032

Shut-off valve, type SVA-S and SVA-L

Table 53: SVA-S Straightway - Socket welding ANSI (B 16.11) inlet, FPT inside pipe thread, NPT (ANSI/ASME B 1.20.1) outlet

Size		Type	MWP		Code number
mm	in.		bar	psi	
20	¾	SVA-S 20 SOC/FPT STR H-WHEEL	52	754	148B6790
20	¾	SVA-S 20 SOC/FPT STR CAP	52	754	148B6792

Table 54: SVA-S Angleway - Socket welding ANSI (B 16.11) inlet, FPT inside pipe thread, NPT (ANSI/ASME B 1.20.1) outlet

Size		Type	MWP		Code number
mm	in.		bar	psi	
20	¾	SVA-S 20 SOC/FPT ANG H-WHEEL	52	754	148B6789
20	¾	SVA-S 20 SOC/FPT ANG CAP	52	754	148B6791

Table 55: SVA-HL Angleway -Butt-weld connection JIS (G3454/3455 Schedule 40)

Size		Type	MWP		Code Number
mm	in.		bar	psi	
50	2	SVA-HL 50 JIS ANG STOP VALVE CAP PS52	52	754	148B6527
65	2½	SVA-HL 65 JIS ANG STOP VALVE CAP PS52	52	754	148B6528
80	3	SVA-HL 80 JIS ANG STOP VALVE CAP PS52	52	754	148B6529
100	4	SVA-HL 100 JIS ANG STOP VALVE CAP PS52	52	754	148B6530
125	5	SVA-HL 125 JIS ANG STOP VALVE CAP PS52	52	754	148B6531
150	6	SVA-HL 150 JIS ANG STOP VALVE CAP PS52	52	754	148B6532

Table 56: SVA-HL Straightway -Butt-weld connection JIS (G3454/3455 Schedule 40)

Size		Type	MWP		Code Number
mm	in.		bar	psi	
50	2	SVA-HL 50 JIS STR STOP VALVE CAP PS52	52	754	148B6538
65	2½	SVA-HL 65 JIS STR STOP VALVE CAP PS52	52	754	148B6539
80	3	SVA-HL 80 JIS STR STOP VALVE CAP PS52	52	754	148B6540
100	4	SVA-HL 100 JIS STR STOP VALVE CAP PS52	52	754	148B6541
125	5	SVA-HL 125 JIS STR STOP VALVE CAP PS52	52	754	148B6542
150	6	SVA-HL 150 JIS STR STOP VALVE CAP PS52	52	754	148B6543

ANG = Angleway
STR = Straightway
CAP = Cap
H-WHEEL = Hand wheel

Ordering SVA-L complete valves

Example:

SVA-L 20 DIN angleway with hand wheel = 148B5340

IMPORTANT:

Where products need to be certified according to specific certification societies or where higher pressures are required, the relevant information should be included at the time of order.

Table 57: SVA-L Angleway - Butt-weld DIN (EN 10220)

Size		Type	MWP		Code number
mm	in.		bar	psi	
15	½	SVA-L 15 D ANG H-WHEEL	52	754	148B5240
15	½	SVA-L 15 D ANG CAP	52	754	148B5241
20	¾	SVA-L 20 D ANG H-WHEEL	52	754	148B5340
20	¾	SVA-L 20 D ANG CAP	52	754	148B5341
25	1	SVA-L 25 D ANG H-WHEEL	52	754	148B5440
25	1	SVA-L 25 D ANG CAP	52	754	148B5441
32	1¼	SVA-L 32 D ANG H-WHEEL	52	754	148B5540
32	1¼	SVA-L 32 D ANG CAP	52	754	148B5541
40	1½	SVA-L 40 D ANG H-WHEEL	52	754	148B5640
40	1½	SVA-L 40 D ANG CAP	52	754	148B5641

Shut-off valve, type SVA-S and SVA-L

Table 58: SVA-L Straightway - Butt-weld DIN (EN 10220)

Size		Type	MWP		Code number
mm	in.		bar	psi	
15	½	SVA-L 15 D STR H-WHEEL	52	754	14885250
15	½	SVA-L 15 D STR CAP	52	754	14885251
20	¾	SVA-L 20 D STR H-WHEEL	52	754	14885350
20	¾	SVA-L 20 D STR CAP	52	754	14885351
25	1	SVA-L 25 D STR H-WHEEL	52	754	14885450
25	1	SVA-L 25 D STR CAP	52	754	14885451
32	1¼	SVA-L 32 D STR H-WHEEL	52	754	14885550
32	1¼	SVA-L 32 D STR CAP	52	754	14885551
40	1½	SVA-L 40 D STR H-WHEEL	52	754	14885650
40	1½	SVA-L 40 D STR CAP	52	754	14885651

Table 59: SVA-L Angleway - Butt-weld ANSI (B 36.10 Schedule 80)

Size		Type	MWP		Code number
mm	in.		bar	psi	
15	½	SVA-L 15 A ANG H-WHEEL	52	754	14885260
15	½	SVA-L 15 A ANG CAP	52	754	14885261
20	¾	SVA-L 20 A ANG H-WHEEL	52	754	14885360
20	¾	SVA-L 20 A ANG CAP	52	754	14885361
25	1	SVA-L 25 A ANG H-WHEEL	52	754	14885460
25	1	SVA-L 25 A ANG CAP	52	754	14885461
32	1¼	SVA-L 32 A ANG H-WHEEL	52	754	14885560
32	1¼	SVA-L 32 A ANG CAP	52	754	14885561
40	1½	SVA-L 40 A ANG H-WHEEL	52	754	14885660
40	1½	SVA-L 40 A ANG CAP	52	754	14885661

Table 60: SVA-L Straightway - Butt-weld ANSI (B 36.10 Schedule 80)

Size		Type	MWP		Code number
mm	in.		bar	psi	
15	½	SVA-L 15 A STR H-WHEEL	52	754	14885270
15	½	SVA-L 15 A STR CAP	52	754	14885271
20	¾	SVA-L 20 A STR H-WHEEL	52	754	14885370
20	¾	SVA-L 20 A STR CAP	52	754	14885371
25	1	SVA-L 25 A STR H-WHEEL	52	754	14885470
25	1	SVA-L 25 A STR CAP	52	754	14885471
32	1¼	SVA-L 32 A STR H-WHEEL	52	754	14885570
32	1¼	SVA-L 32 A STR CAP	52	754	14885571
40	1½	SVA-L 40 A STR H-WHEEL	52	754	14885670
40	1½	SVA-L 40 A STR CAP	52	754	14885671

Table 61: SVA-L Angleway - Socket welding ANSI (B 16.11)

Size		Type	MWP		Code number
mm	in.		bar	psi	
15	½	SVA-L 15 SOC ANG H-WHEEL	52	754	14885262
15	½	SVA-L 15 SOC ANG CAP	52	754	14885263
20	¾	SVA-L 20 SOC ANG H-WHEEL	52	754	14885362
20	¾	SVA-L 20 SOC ANG CAP	52	754	14885363
25	1	SVA-L 25 SOC ANG H-WHEEL	52	754	14885462
25	1	SVA-L 25 SOC ANG CAP	52	754	14885463
32	1¼	SVA-L 32 SOC ANG H-WHEEL	52	754	14885562
32	1¼	SVA-L 32 SOC ANG CAP	52	754	14885563
40	1½	SVA-L 40 SOC ANG H-WHEEL	52	754	14885662
40	1½	SVA-L 40 SOC ANG CAP	52	754	14885663

Shut-off valve, type SVA-S and SVA-L

Table 62: SVA-L Straightway - Socket welding ANSI (B 16.11)

Size		Type	MWP		Code number
mm	in.		bar	psi	
15	½	SVA-L 15 SOC STR H-WHEEL	52	754	14885272
15	½	SVA-L 15 SOC STR CAP	52	754	14885273
20	¾	SVA-L 20 SOC STR H-WHEEL	52	754	14885372
20	¾	SVA-L 20 SOC STR CAP	52	754	14885373
25	1	SVA-L 25 SOC STR H-WHEEL	52	754	14885472
25	1	SVA-L 25 SOC STR CAP	52	754	14885473
32	1¼	SVA-L 32 SOC STR H-WHEEL	52	754	14885572
32	1¼	SVA-L 32 SOC STR CAP	52	754	14885573
40	1½	SVA-L 40 SOC STR H-WHEEL	52	754	14885672
40	1½	SVA-L 40 SOC STR CAP	52	754	14885673

Table 63: SVA-L Angleway - FPT inside pipe thread, NPT (ANSI/ASME B 1.20.1)

Size		Type	MWP		Code number
mm	in.		bar	psi	
15	½	SVA-L 15 FPT ANG H-WHEEL	52	754	14885264
15	½	SVA-L 15 FPT ANG CAP	52	754	14885265
20	¾	SVA-L 20 FPT ANG H-WHEEL	52	754	14885364
20	¾	SVA-L 20 FPT ANG CAP	52	754	14885365
25	1	SVA-L 25 FPT ANG H-WHEEL	52	754	14885464
25	1	SVA-L 25 FPT ANG CAP	52	754	14885465
32	1¼	SVA-L 32 FPT ANG H-WHEEL	52	754	14885564
32	1¼	SVA-L 32 FPT ANG CAP	52	754	14885565

Table 64: SVA-L Straightway - FPT inside pipe thread, NPT (ANSI/ASME B 1.20.1)

Size		Type	MWP		Code number
mm	in.		bar	psi	
15	½	SVA-L 15 FPT STR H-WHEEL	52	754	14885274
15	½	SVA-L 15 FPT STR CAP	52	754	14885275
20	¾	SVA-L 20 FPT STR H-WHEEL	52	754	14885374
20	¾	SVA-L 20 FPT STR CAP	52	754	14885375
25	1	SVA-L 25 FPT STR H-WHEEL	52	754	14885474
25	1	SVA-L 25 FPT STR CAP	52	754	14885475
32	1¼	SVA-L 32 FPT STR H-WHEEL	52	754	14885574
32	1¼	SVA-L 32 FPT STR CAP	52	754	14885575

Table 65: SVA-HL Angleway -Butt-weld connection JIS (G3454/3455 Schedule 80)

Size		Type	MWP		Code Number
mm	in.		bar	psi	
15	½	SVA-HL 15 JIS ANG STOP VALVE CAP PS52	52	754	14886522
20	¾	SVA-HL 20 JIS ANG STOP VALVE CAP PS52	52	754	14886523
25	1	SVA-HL 25 JIS ANG STOP VALVE CAP PS52	52	754	14886524
32	1¼	SVA-HL 32 JIS ANG STOP VALVE CAP PS52	52	754	14886525
40	1½	SVA-HL 40 JIS ANG STOP VALVE CAP PS52	52	754	14886526

Table 66: SVA-HL Straightway -Butt-weld connection JIS (G3454/3455 Schedule 80)

Size		Type	MWP		Code Number
mm	in.		bar	psi	
15	½	SVA-HL 15 JIS STR STOP VALVE CAP PS52	52	754	14886533
20	¾	SVA-HL 20 JIS STR STOP VALVE CAP PS52	52	754	14886534
25	1	SVA-HL 25 JIS STR STOP VALVE CAP PS52	52	754	14886535
32	1¼	SVA-HL 32 JIS STR STOP VALVE CAP PS52	52	754	14886536
40	1½	SVA-HL 40 JIS STR STOP VALVE CAP PS52	52	754	14886537

Shut-off valve, type SVA-S and SVA-L

ANG = Angleway
STR = Straightway
CAP = Cap
H-WHEEL = Hand wheel

Accessories

Table 67: 6T Nipple Kit solution

Code no.	Description
148B4245	ACCESSORY WELD.NIPPLE DN6 A + UNION NUT
148B4184	ACCESSORY WELD.NIPPLE DN6 D + UNION NUT

Ordering SVA-S from the parts programme

Example (select from below two tables)

Figure 34: SVA-S parts assembling

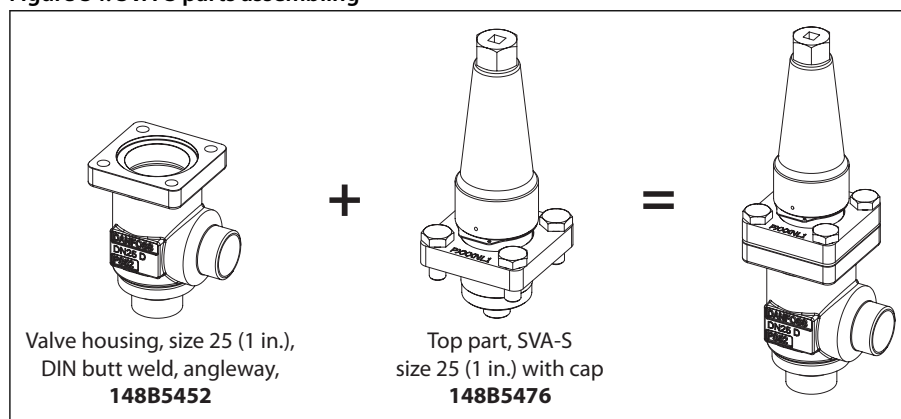

Figure 35: DN 6-10 mm (¼ - ⅜ in.)

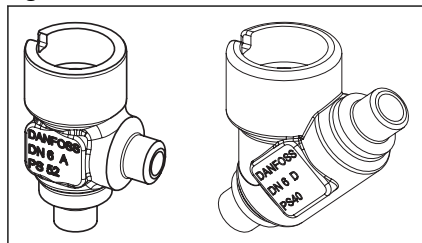

Figure 36: DN 15-65 mm (½ - 2½ in.)

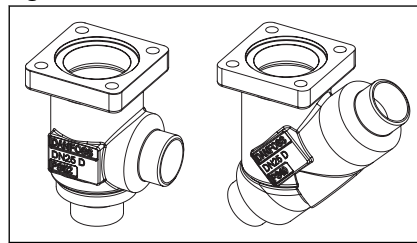

Figure 37: DN 80-125 mm (3 - 5 in.)

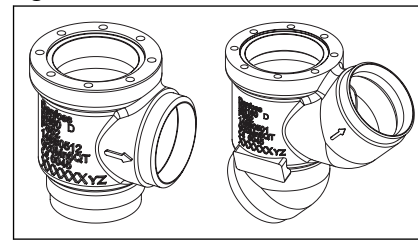

Table 68: SVL valve housings w/different connections

Sizes [DN]		Valve Housing SVL											
		DIN-Butt weld		ANSI-Butt weld		GOST-Butt-weld		SOC		FPT		T	
mm	in.	ANG	STR	ANG	STR	ANG	STR	ANG	STR	ANG	STR	ANG	
6	¼	148B5002	148B5003	148B5004	148B5005	-	-	-	-	-	-	-	148B5012
10	⅜	148B5122	148B5123	148B5124	148B5125	148B5134	148B5135	-	-	-	-	-	-
15	½	148B5252	148B5253	148B5254	148B5255	148B5391	148B5392	148B5256	148B5257	148B5258	148B5259	-	-
20	¾	148B5352	148B5353	148B5354	148B5355	148B5393	148B5394	148B5356	148B5357	148B5358	148B5359	-	-
25	1	148B5452	148B5453	148B5454	148B5455	148B5498	148B5499	148B5456	148B5457	148B5458	148B5459	-	-
32	1¼	148B5576	148B5577	148B5578	148B5579	148B5593	148B5594	148B5580	148B5581	148B5582	148B5583	-	-
40	1½	148B5652	148B5653	148B5654	148B5655	148B5681	148B5682	148B5656	148B5657	-	-	-	-
50	2	148B5741	148B5742	148B5743	148B5744	148B5759	148B5760	148B5745	148B5746	-	-	-	-
65	2½	148B5816	148B5817	148B5818	148B5819	148B5816	148B5817	-	-	-	-	-	-
80	3	148B5912	148B5913	148B5914	148B5915	148B5912	148B5913	-	-	-	-	-	-
100	4	148B6014	148B6015	148B6016	148B6017	148B6033	148B6034	-	-	-	-	-	-
125	5	148B6112	148B6113	148B6114	148B6115	148B6133	148B6134	-	-	-	-	-	-

NOTE:

Not all sizes available for SVA-L - see next following table

Shut-off valve, type SVA-S and SVA-L

Figure 38: SVA complete top parts

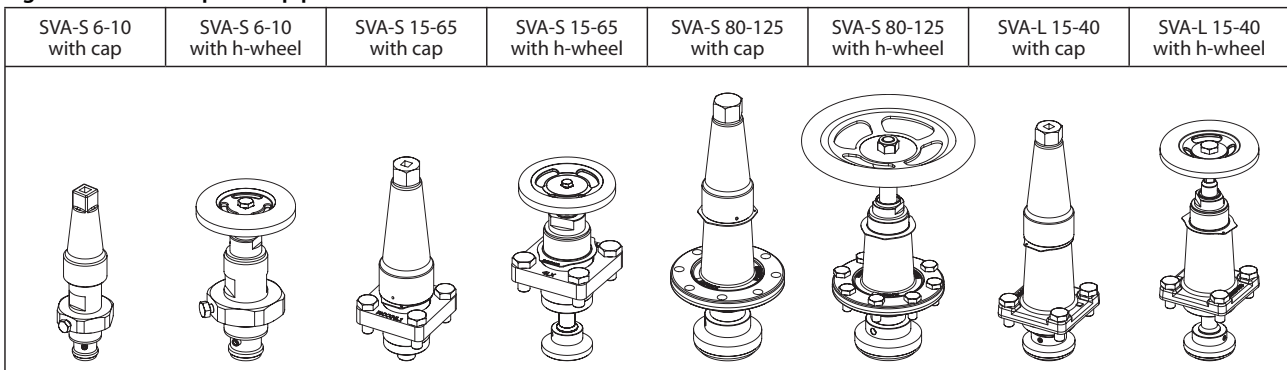

Table 69: SVA complete top part including gaskets and bolts

Sizes [DN]		Complete top part			
mm	in.	SVA-S CAP	SVA-S H-WHEEL	SVA-L CAP	SVA-L H-WHEEL
6	¼	148B5013	148B5014	-	-
10	⅜			-	-
15	½	148B5276	148B5277	148B5278	148B5279
20	¾				
25	1	148B5476	148B5477	148B5478	148B5479
32	1¼				
40	1½	148B5728	148B5729	-	-
50	2				
65	2½	148B5822	148B5823	-	-
80	3	148B5916	148B5917	-	-
100	4	148B6012	148B6018	-	-
125	5	148B6116	148B6117	-	-

Certificates, declarations, and approvals

The list contains all certificates, declarations, and approvals for this product type. Individual code number may have some or all of these approvals, and certain local approvals may not appear on the list.

Some approvals may change over time. You can check the most current status at danfoss.com or contact your local Danfoss representative if you have any questions.

Valid approvals

Table 70: Pressure Equipment Directive (PED)

	SVA valves are approved according to the European standard specified in the Pressure Equipment Directive and are CE marked.
---	---

For further details / restrictions - see Installation Instruction.

Table 71: SVA

Nominal bore	SVA		
	DN≤ 25 mm (1 in.)	DN32-80 mm (1¼ - 3 in.)	DN100 - 200 mm (4-8 in.)
Classified for	Fluid group I		
Category	Article 3, paragraph 3	II	III

Table 72: Certificates and declarations

File name	Document type	Document topic	Approval authority
03709-F0 BV	Marine - Safety Certificate	-	BV
TAP0000003 Rev. 1	Marine - Safety Certificate	-	DNV GL
033F0685.AK	EU Declaration	EMCD/PED	Danfoss
033F0691.AE	Manufacturers Declaration	RoHS	Danfoss
0045 202 1204 Z 00354 19 D 001(00)	Pressure - Safety Certificate	PED	TÜV
0045 202 1204 Z 00355 19 D 001(00)	Pressure - Safety Certificate	-	TÜV
033F0453.AD	Manufacturers Declaration	ATEX	Danfoss
19.10048.266	Marine - Safety Certificate	-	RMRS

Online support

Danfoss offers a wide range of support along with our products, including digital product information, software, mobile apps, and expert guidance. See the possibilities below.

The Danfoss Product Store



The Danfoss Product Store is your one-stop shop for everything product related—no matter where you are in the world or what area of the cooling industry you work in. Get quick access to essential information like product specs, code numbers, technical documentation, certifications, accessories, and more.

Start browsing at store.danfoss.com.

Find technical documentation



Find the technical documentation you need to get your project up and running. Get direct access to our official collection of data sheets, certificates and declarations, manuals and guides, 3D models and drawings, case stories, brochures, and much more.

Start searching now at www.danfoss.com/en/service-and-support/documentation.

Danfoss Learning



Danfoss Learning is a free online learning platform. It features courses and materials specifically designed to help engineers, installers, service technicians, and wholesalers better understand the products, applications, industry topics, and trends that will help you do your job better.

Create your Danfoss Learning account for free at www.danfoss.com/en/service-and-support/learning.

Get local information and support



Local Danfoss websites are the main sources for help and information about our company and products. Find product availability, get the latest regional news, or connect with a nearby expert—all in your own language.

Find your local Danfoss website here: www.danfoss.com/en/choose-region.

Spare Parts



Get access to the Danfoss spare parts and service kit catalog right from your smartphone. The app contains a wide range of components for air conditioning and refrigeration applications, such as valves, strainers, pressure switches, and sensors.

Download the Spare Parts app for free at www.danfoss.com/en/service-and-support/downloads.

Coolselector®2 - find the best components for you HVAC/R system



Coolselector®2 makes it easy for engineers, consultants, and designers to find and order the best components for refrigeration and air conditioning systems. Run calculations based on your operating conditions and then choose the best setup for your system design.

Download Coolselector®2 for free at coolselector.danfoss.com.

Danfoss A/S

Climate Solutions • danfoss.com • +45 7488 2222

Any information, including, but not limited to information on selection of product, its application or use, product design, weight, dimensions, capacity or any other technical data in product manuals, catalogues descriptions, advertisements, etc. and whether made available in writing, orally, electronically, online or via download, shall be considered informative, and is only binding if and to the extent, explicit reference is made in a quotation or order confirmation. Danfoss cannot accept any responsibility for possible errors in catalogues, brochures, videos and other material. Danfoss reserves the right to alter its products without notice. This also applies to products ordered but not delivered provided that such alterations can be made without changes to form, fit or function of the product.

All trademarks in this material are property of Danfoss A/S or Danfoss group companies. Danfoss and the Danfoss logo are trademarks of Danfoss A/S. All rights reserved.