

Directional Control Valves

CP710-8

Directional Control Valve, 2-Way, Spool Type, Hydraulic Pilot, External Drain

210 bar [3000 psi] • 40 l/min [11 US gpm]

DESCRIPTION AND OPERATION

This is a 2-way, spool type, hydraulically piloted directional control valve with external drain. It is available in normally open or normally closed configurations between ports 2 and 3 that shift when pilot pressure is applied to port 1. Due to the external drain, the pilot pressure required shift the valve is dependent on the pressure in port 4, which would normally be connected to tank.

SCHEMATIC

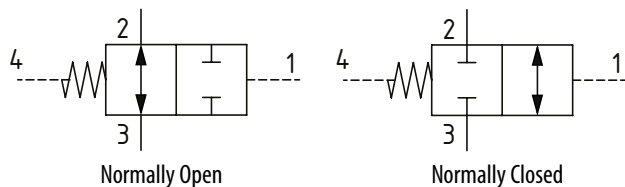

DIMENSIONS

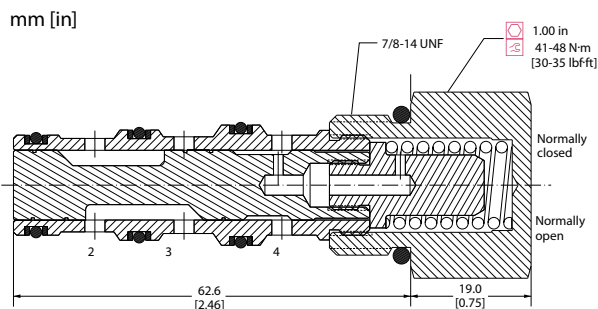

PERFORMANCE DATA

Rated pressure	210 bar [3000 psi]
Rated flow @ 7 bar [100 psi]	40 l/min [11 US gpm]
Weight	0.15 kg [0.33 lb]
Cavity	SDC10-4

PERFORMANCE CURVES

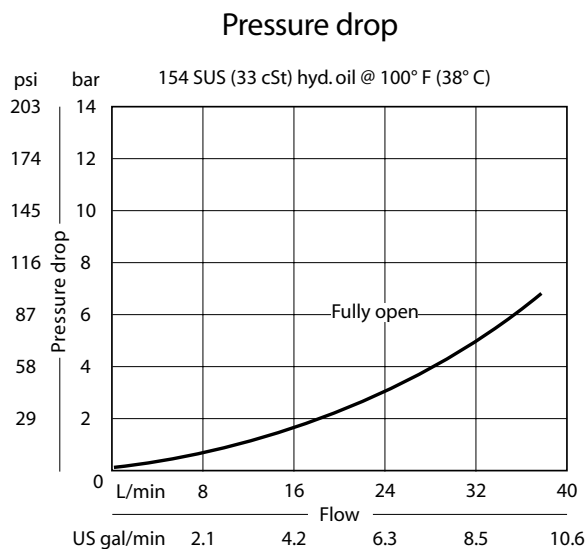

MODEL CODE

CP710 - 8 - B - 6S - C - 080

Seal Option

Code	Seal kit
B	Buna-N 120009
V	Viton 120010

Housing

Code	Ports & Material	Housing Model Code
0	No Housing	
L3B	AL, 3/8 BSP	SDC10-4-L-3B
L4B	AL, 1/2 BSP	SDC10-4-L-4B
6S	AL, #6 SAE	CP10-4-6S
8S	AL, #8 SAE	CP10-4-8S

* Aluminum bodies are to be used for pressures less than 210 bar [3000 psi].
* Additional housings available

Shift Pressure

Code	Bar	[Psi]
040	2.8	[40]
080	5.5	[80]
150	10.3	[150]

Spool Configuration

0-Normally Open
C-Normally Closed