

Motion Control Valves

1CE300

Overcenter Valve, Standard, Differential Area, Internal Drain, Port 3 Pilot

350 bar [5000 psi] • 300 l/min [80 US gpm]

DESCRIPTION AND OPERATION

This is a differential area overcenter valve, which is a pilot assisted relief with a free flow check. With the relief valve set at around 1.3 times the maximum load induced pressure, the valve will prevent flow from taking place between ports 1 and 2. When pilot pressure is applied to port 3, the valve will meter the flow from port 1 to 2, compensating for any change in pilot pressure due to over-running or unstable loads. Free flow takes place from port 2 to port 1 through the check portion of the valve. These valves are ideal in most applications bringing stability, load holding, and hose failure protection when the valve is mounted onto or into the actuator. The spring chamber is connected to the valve port 2 so any back pressure will increase the pilot pressure required to keep the valve open and the pressure at which the valve will open as a relief valve. This is also available in a dual housing for bi-directional control.

SCHEMATIC

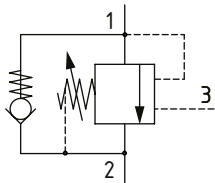

PERFORMANCE DATA

Rated pressure	350 bar [5000 psi]
Rated flow	300 l/min [80 US gpm]
Max total relief pressure	350 bar [5000 psi]
Max recommended load pressure at max setting	270 bar [3900 psi]
Pilot Ratio	3:1, 8:1
Leakage	4 ml/min nominal [60 drops/min]
Weight	0.91 kg [2.0 lb]
Cavity	A6935

DIMENSIONS

mm [in]

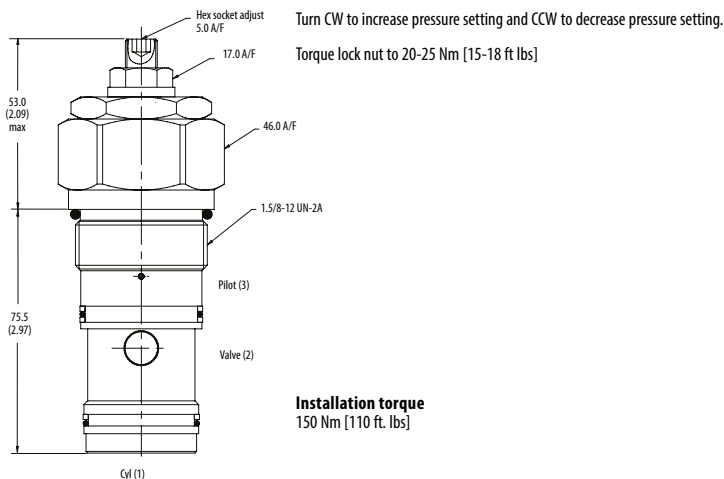

PERFORMANCE CURVES

Pressure Drop

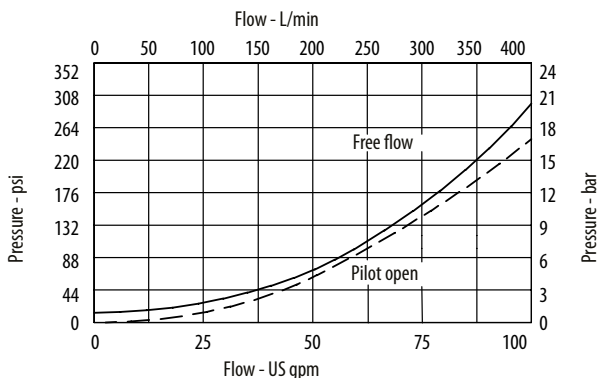

Motion Control Valves

1CE300

Overcenter Valve, Standard, Differential Area, Internal Drain, Port 3 Pilot

350 bar [5000 psi] • 300 l/min [80 US gpm]

■ SCHEMATIC

1CEE350 (dual)

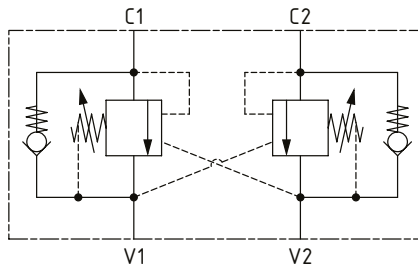

■ DIMENSIONS

mm [in]

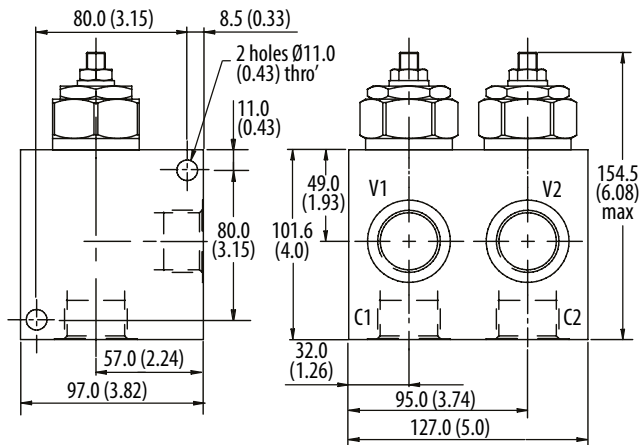

■ MODEL CODE

1CE350 - F - 10W - 35 - S - 3 - 377 - 210

Basic Code

- 1CE300 - No housing
- 1CE350 - Cartridge and housing
- 1CEE350 - Cartridges and dual housing

Adjustment Option

- F - External

Housing

Code	Ports	Aluminum single	Steel single	Aluminum dual	Steel dual
Omit	No housing				
10W	1 1/4" BSP Valve & Cyl Port 1/4" BSP Pilot Port	B6814	B8610	C8704	C8705
20T	1 1/4" SAE Valve & Cyl Port 1/4" SAE Pilot Port	B10630	B11474	C10811	C11564

* Aluminum bodies are to be used for pressures less than 210 bar [3000 psi].

* Additional housings available

Pressure Setting

Code Pressure setting in bar (10 bar increments within specified Pressure Range)
 XXX-Standard setting (see Pressure Range for value). Example:

Code	Bar	Psi
210	210	[3000]

Housing Material

- Omit - Aluminum/No housing
- 377 - Steel

Pilot Ratio

- 3 - 3:1
- 8 - 8:1

Seal Option

Code	Seal kit
S-Buna - N	SK437
SV-Viton	SK437V

Pressure Range

Code	Bar	Psi
35	70-350	[3015-5000]
Standard Setting	210	[3000]

Std setting made at 4.5 l/min