

Motion Control Valves

1SE30

Overcenter Valve, Standard, Direct Acting, Internal Drain, Port 3 Pilot

350 bar [5000 psi] • 30 l/min [8 US gpm]

DESCRIPTION AND OPERATION

This is a direct acting overcenter valve, which is a pilot assisted relief with a free flow check. With the relief valve set at approximately 1.3 times the maximum load induced pressure, the valve will prevent flow from port 1 to 2. When pilot pressure is applied to port 3, the valve will meter the flow from port 1 to 2, compensating for any change in pilot pressure due to over-running or unstable loads. Free flow takes place from port 2 to port 1 through the check portion of the valve. These valves are ideal in most applications bringing stability, load holding, and hose failure protection when the valve is mounted onto or into the actuator. The spring chamber is connected to the valve port 2, so any back pressure will increase the pilot pressure required to keep the valve open and the pressure at which the valve will open as a relief valve.

SCHEMATIC

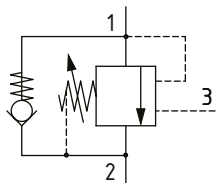

PERFORMANCE DATA

Rated pressure	350 bar [5000 psi]
Rated flow	30 l/min [8 US gpm]
Max total relief pressure	350 bar [5000 psi]
Max recommended load pressure at max setting	270 bar [3900 psi]
Pilot Ratio	2.5:1, 5:1, 10:1
Leakage	0.3 ml/min nominal [5 drops/min]
Weight	0.15 kg [0.33 lb]
Cavity	A20090-T11A

PERFORMANCE CURVES

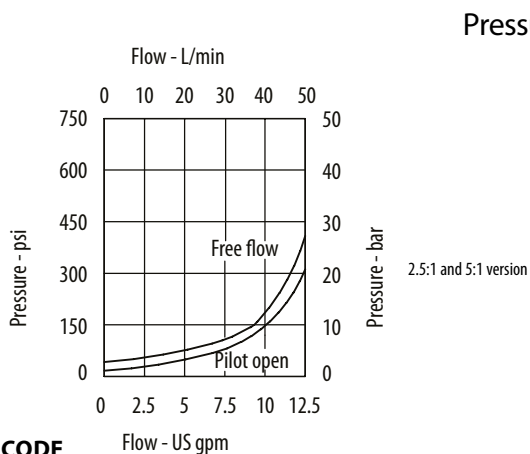

DIMENSIONS

mm [in]

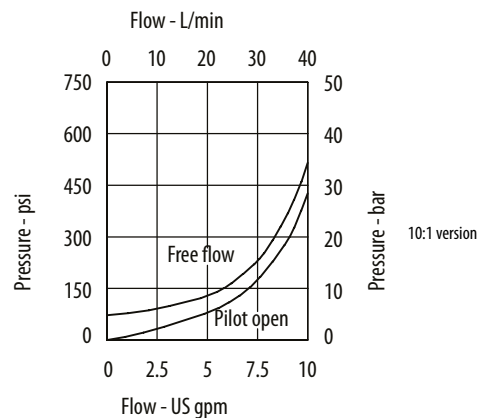
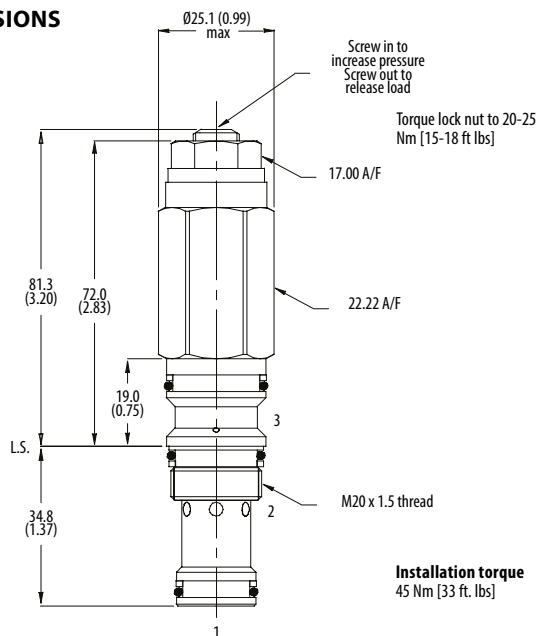

MODEL CODE

1SE30 - F - 35 - S - 5 - 210

Adjustment Option

F - External
N - Non-adjustable option, contact technical support

Pressure Range

Code	Pilot Ratio 2		Pilot Ratio 5		Pilot Ratio 10	
	Bar	Psi	Bar	Psi	Bar	Psi
20	70-225	[1015-3260]	70-225	[1015-3260]	70-225	[1015-3260]
Standard setting	100	[1450]	100	[1450]	100	[1450]
35	70-350	[1015-5000]	70-350	[1015-5000]	[120-350]	[1300-5000]
Standard setting	210	[3000]	210	[3000]	[210]	[3000]

Note: Std setting made at 4.5 l/min

Pressure Setting

Code Pressure setting in bar (10 bar increments within specified Pressure Range)
XXX - Standard setting (see Pressure Range for value)
Example:

Pilot Ratio

Pilot Ratio	Code	Bar	Psi
2 - 2.5:1			
5 - 5:1	210	210	[3000]
10 - 10:1			

Seal Option

Code	Seal kit
S-Buna-N	SK1079
SV-Viton	SK1079V