

# Motion Control Valves

## 1SEL140

Overcenter Valve, Two Stage Counterbalance, Direct Acting, Port 3 Pilot

380 bar [5500 psi] • 140 l/min [37 US gpm]

### DESCRIPTION AND OPERATION

This is a direct acting overcenter valve, which is a pilot assisted relief valve with a free flow check. With the total relief pressure setting (fixed pressure relief setting plus counterbalance pressure setting) set at around 1.3 times the maximum load induced pressure, the valve will prevent flow from taking place between ports 1 and 2. The relationship between the two settings will be application dependent. The more unstable the application, the higher the counterbalance pressure setting should be with the fixed pressure relief setting making up the remainder of the setting. When pilot pressure is applied to port 3, it acts on two separate areas, one gives a very low pilot ratio 0.4 to 1 and the other slightly higher 4.3 to 1. When piloted, the valve will meter the flow from port 1 to 2 compensating for any change in pilot pressure due to over-running or unstable loads. If the load pressure decays very quickly, then the lower pilot ratio poppet will return at a high pilot pressure preventing total loss of control and subsequent instability. As the pilot pressure increases, the counterbalance portion of the pressure will be removed allowing full cylinder force to ensue. Free flow from port 2 to port 1 can take place freely through the check portion of the valve. These valves are ideal in the most severe applications bringing stability, load holding, and hose failure protection to long slender booms and traditionally unstable applications.

### SCHEMATIC

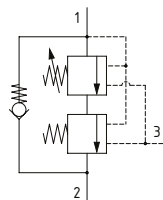

### PERFORMANCE DATA

Rated pressure	380 bar [5500 psi]
Rated flow	140 l/min [37 US gpm]
Max total relief pressure	380 bar [5500 psi]
Max recommended load pressure at max setting	280 bar [4000 psi]
Pilot Ratio	6.1:1 (Primary); 0.5:1 (Secondary)
Leakage	0.3 ml/min nominal [5 drops/min]
Weight	1.2 kg [2.5 lb]
Cavity	A20094-T17A

### MODEL CODE

1SEL140 - F - 30 - S - 220 - 60

#### Adjustment Option

F - External  
N - Non-adjustable option, contact technical support

#### Total Relief Pressure Range

Code	Fixed Pressure Range				Counterbalance Pressure Range	
	Bar	Psi	Bar	Psi	Bar	Psi
20	170-320	[2465-4640]	150-200	[2175-2900]	20-100	[290-1450]
Standard Setting	220	[3190]	160	[2320]	60	[870]
30	230-380	[3480-5500]	220-270	[3190-3900]	20-100	[290-1450]
Standard Setting	280	[4060]	220	[3190]	60	[870]
40	310-380	[4500-5500]	250-310	[3630-4500]	20-100	[290-1450]
Standard Setting	350	[5000]	290	[4200]	60	[870]

Std setting made at 4.5 l/min

#### Counterbalance Pressure Setting

Code - Pressure setting in bar (10 bar increments within specified Pressure Range)

Code	Bar	Psi
60	60	[870]

#### Fixed Pressure Setting

Code - Pressure setting in bar (10 bar increments within specified Pressure Range)

Code	Bar	Psi
220	220	[3190]

#### Seal Option

Code	Seal kit
S-Buna-N	SK1116
SV-Viton	SK1116V

### DIMENSIONS

mm [in]

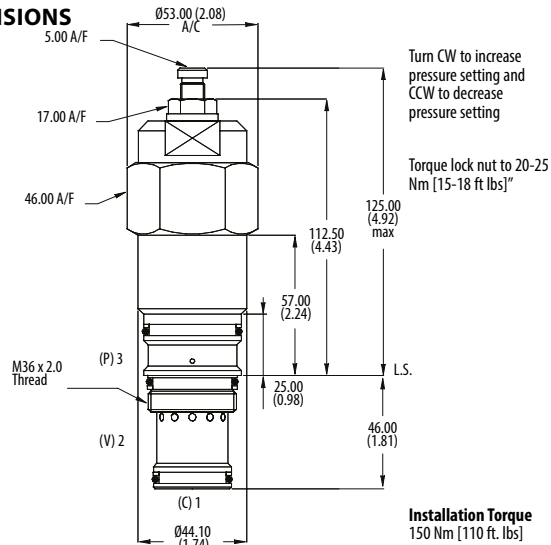

### PERFORMANCE CURVES

#### Pressure Drop

