

Sequence and Unloading Valves

1UL60

Unloading Valve, Pilot Operated, Spool Type, Hydraulic Pilot, Internal Drain

350 bar [5000 psi] • 60 l/min [16 US gpm]

DESCRIPTION AND OPERATION

This is a pilot operated, spool type unloading valve. Normally used in conjunction with a check valve, the valve remains closed from port 1 to 2 until the set pressure is reached. Pressure sensed downstream of the check valve at port 3 will pilot the valve open, allowing the pressure at port 1 unload to tank (port 2) at minimum pressure. When the pressure in port 3 falls to 85% of the setting, the valve will close and the pressure in port 1 will rise. This valve can be used to dump the pump flow at minimum pressure in an accumulator system or in a two-pump unloading circuit.

SCHEMATIC

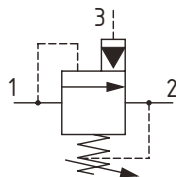

PERFORMANCE DATA

Rated pressure	350 bar [5000 psi]
Rated flow	60 l/min [16 US gpm]
Leakage	35ml/min nominal
Pressure Ratio	85-90%
Weight	0.46 kg [1.01 lb]
Cavity	A3146

DIMENSIONS

mm [in]

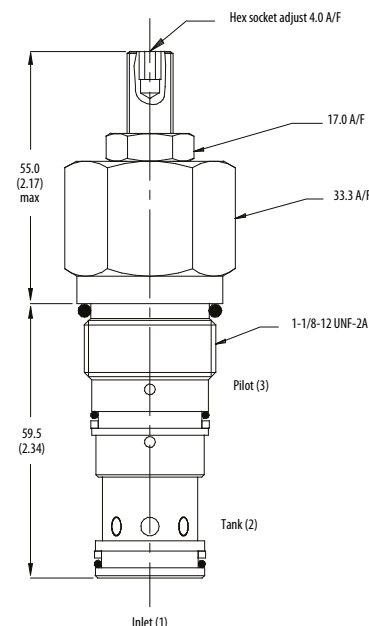

Installation torque
75 Nm [55 ft. lbs]

PERFORMANCE CURVES

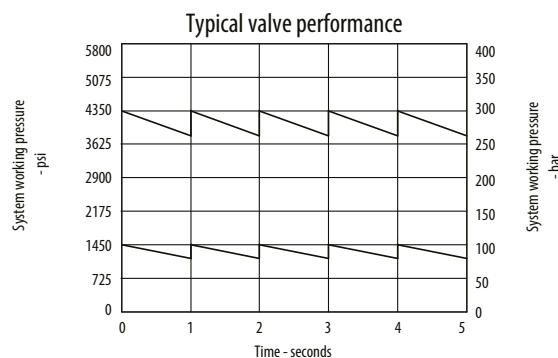

MODEL CODE

1UL65 - P - 4W - 35 - S - 377 - 60

Basic Code

1UL60 - No Housing
1UL65 - Cartridge and Housing

Adjustment Option

P - External
G - Tamper Resistant

Housing

Code	Ports	Housing Model Code	
		Aluminium	Steel
Omit	No Housing		
4W	1/2" BSP		BXP24103-4W-S-377
8T	1/2" SAE		BXP24103-8T-S

* Aluminium bodies are to be used for pressures less than 210 bar [3000 psi].

* Additional housings available

Pressure Setting

Code - Pressure setting in bar (5 bar increments within specified Pressure Range)
XXX - Standard setting (see Pressure Range for value)
Example:

Housing Material

Omit - Aluminum/No Housing
377 - Steel

Seal Option

Code	Seal Kit
S-Buna-N	SK451
SV-Viton	SK451V

Pressure Range

Code	Bar	Psi
10	40-100	[580-1450]
Standard Setting	75	[1090]
20	70-210	[1015-3000]
Standard Setting	100	[1450]
35	150-350	[2200-5000]
Standard Setting	200	[2900]

Setting made at 4.8 l/min