

Installation Guide

Electronic Heat Cost Allocator INDIV-X-10V, INDIV-X-10W Radio



0.0 Table of Contents

1. General	3	2.6 Error	21
1.1 Introduction.....	3	2.6.1 Description of the Function Control	21
1.2 Application.....	3	2.6.2 List of Errors	22
2. Specification	4	2.7 Radio Standby – Radio-HCA INDIV-X-10W	22
2.1 General Description	4	2.7.1 Sleeping Mode	22
2.1.1 Type	4	2.7.2 Installation Mode.....	22
2.1.2 Design	4	2.7.3 Operation Mode.....	23
2.1.3 Characteristics.....	4	3. Installation	24
2.1.4 Display.....	5	3.1 Introduction.....	24
2.1.5 Electronics	5	3.2 DIN Standard Requirements for the Installation.....	24
2.1.6 Versions.....	5	3.3 General Restrictions	25
2.1.7 Optical Interface.....	5	3.4 Operating Range	25
2.1.8 Radio Transmission	5	3.5 Installation to the Radiator.....	26
2.2 Operating mode.....	6	3.6 Wall-Mounting	27
2.2.1 Cycle Time.....	6	3.7 Installation of Fastening-Parts Kits.....	28
2.2.2 Single Sensor Version with Start Sensor.....	6	3.7.1 Installation to Sectional Radiator	28
2.2.3 Double Sensor Version.....	6	3.7.2 Wall-Mounting - Sectional Radiator	28
2.2.4 Comparison of the Measuring Principles.....	7	3.7.3 Installation to Folded Radiator	29
2.2.5 Temperature Measurement and Calculation	7	3.7.4 Wall-Mounting – Folded Radiator	30
2.2.6 Calculation of the Displayed Consumption Value	8	3.7.5 Installation to Panel-Type Radiator	31
2.2.7 Start of Counting	9	3.7.6 Wall-Mounting - Panel-Type Radiator.....	32
2.3 Display and Additional Functions	10	3.7.7 Installation to Panel-Type Radiator with Front Convection Plate.....	33
2.3.1 The Menu Sequences of the Digital Display.....	10	3.7.8 Bathroom radiator – Towel rails	34
2.3.2 The Digital Displays.....	12	3.7.9 Sectional radiator wide	35
2.3.3 Rolling Digital Display	15	3.8 Overview mounting accessories.....	36
2.3.4 Energy-Saving Night Mode between 20.00 and 6.00 h	16	3.9 Mounting and Sealing	37
2.3.5 Communication Indicator	16	4. Commissioning	38
2.3.6 Real Time Clock and Calendar.....	16	5. Readout	39
2.3.7 Readout.....	17	5.1 Manual Readout.....	39
2.3.8 Check Code	17	5.2 Readout over the Optical Interface	39
2.3.9 Change of Battery	18	5.2.1 Optical Probe.....	39
2.3.10 Protection against Outside Influences	18	5.2.2 Transmission Protocol	39
2.4 Special Functions.....	19	5.2.3 Timing of the Optical Interface	40
2.4.1 Suppression of Summer Counting.....	19	5.2.4 Frames of the Optical Readout	41
2.4.2 Programmable Start Temperature of Summer and Winter period	19	5.2.5 Remote Radio Readout	43
2.4.3 Annual Reset of the Values	19	5.2.6 Stationary Readout	44
2.4.4 Unit Scale and Product Scale	19		
2.5 Parameterisation	21		

Installation Guide Electronic Heat Cost Allocator INDIV-X-10V, INDIV-X-10W Radio

0.0 Table of Contents

5.2.7	Timing of Radio Transmission	44
5.2.8	Frame of the Radio Transmission	45
6.	Rating factors	46
6.1	Taking Measurements	46
6.1.1	Rating of Radiators of Over Length or High Nominal Output.....	46
6.1.2	Rating of Radiator	47
6.2	Table of Rating factors	48
7.	Technical Data	50
7.1	Dimensional Drawing.....	51
8.	Enclosure	52
8.1	Enclosure 1.....	52
8.2	Enclosure 2.....	53
8.3	Temperature Limits acc. to EN 834.....	54
8.4	Calculation of Temperature – Interpolation Table	55
8.5	Rating factors acc. to EN 834	56

Installation Guide Electronic Heat Cost Allocator INDIV-X-10V, INDIV-X-10W Radio

1. General

1.1 Introduction

This installation guide is used for the users and the service personnel of the Danfoss heat cost allocators. It describes the handling of the heat cost allocator INDIV-X-10V and the radio heat cost allocator INDIV-X-10W. Since the measuring functions are the same for both heat cost allocators the descriptions in this guide apply for both versions. In case of deviations, a special note is made to this end.

Primarily, the installation of the heat cost allocator to the most common radiator types is described. Apart from the information on the installation of the heat cost allocator, basic information (rating of heat cost allocators) is given and special features of our devices (design, function, installation) are described in this guide as well.

1.2 Application

The heat cost allocator is an accessory measuring device to record the heat output of radiators in units.

Units are apartments, office-, and business-, commercial or industrial premises where the heat is supplied by a conjoint central heating system or via a conjoint district heating station.

The entity of the units forms a billing unit.

If one billing unit consists of units with typical differences (e.g. technical differences such as different heating systems or different consumptions of e.g. industrial premises and apartments), a sub-division of the billing unit in unit groups may be necessary.

Each radiator is equipped with a heat cost allocator which records and assesses the heat output of the radiator and displays the consumption value. The consumption value is the basis for allocating the heating costs to each unit which is necessary for the annual billing of the heating costs.

Installation Guide Electronic Heat Cost Allocator INDIV-X-10V, INDIV-X-10W Radio

2. Specification

2.1 General Description

2.1.1 Type

The electronic heat cost allocators Danfoss INDIV-X-10V / INDIV-X-10W operate either according to the single sensor principle with start sensor or the double sensor principle. The device has been developed and approved in accordance with the European Standard EN 834:2013.

2.1.2 Design

The heat cost allocator consists of a microprocessor, a lithium battery, two temperature sensors, a heat conducting aluminium back plate, a multi-functional display and a plastic housing. The measuring circuit consists of the temperature sensors, the analogue-digital conversion, the reference resistance for standardising the measuring transformation and the microprocessor for accessing the radiator heat output. During each measuring the circuit tolerances are eliminated with a reference resistance and the heat cost allocator carries out an automatic self-test.

2.1.3 Characteristics

- Measuring by two temperature sensors, radiator and ambient temperature sensor (NTC-resistor)
- Optional measuring principle: 1 sensor mode with start sensor or two sensor mode
- Unit scale or product scale
- Recording of cumulated heat consumption on the annual set day
- Recording of 36 monthly values or 18 monthly and half monthly values
- Optical interface for the readout of the data and programming
- Readout via radio optional with a mobile radio modem or directly by the billing office over the radio central installed outside the unit
- User-friendly operation by push button
- 6-digit and high-contrast LCD display
- Check code for postcard mail-in method
- Remote sensor version with 1.5 m cable
- Standard aluminium back plate for nearly all existing bolts with common dimensions and installation possibilities – thus easy installation (no cutting and welding of bolts necessary)
- Snap-on blind to cover colour shadows for increased aesthetics
- Safe operation and fraud detection
- Factory seal protecting against unauthorized manipulation
- Possibility to use seal sticker as second seal for further protecting against manipulation
- Lithium battery with a capacity of up to 10+1 years
- Meets EN 834:2013.

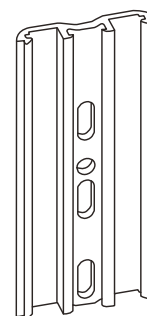
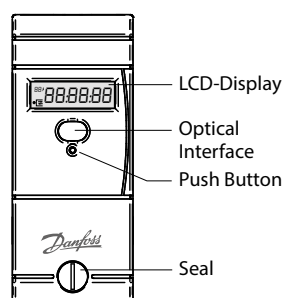

Standard aluminium back plate for nearly all existing bolts with common dimensions and mounting possibilities – thus easy installation.

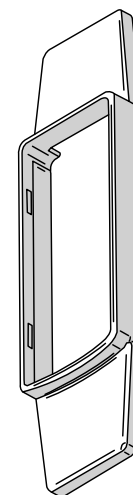

Snap-on blind to cover colour shadows for increased aesthetics.

Installation Guide Electronic Heat Cost Allocator INDIV-X-10V, INDIV-X-10W Radio

2. Specification

2.1.4 Display

The heat cost allocator has a LCD-display with 6 large main digits on the right and 2 smaller digits on the left as well as two special symbols and one communication indicator. The main digits are separated by four decimal points. Below, please find the display segments:



Display with all active segments

Normally, the heat cost allocators INDIV-X-10V / INDIV-X-10W are supplied with switched-off LCD-display. On request, the heat cost allocators can also be supplied with permanent LCD- display.

2.1.5 Electronics

The device has an electrical circuitry with an 8-Bit-CMOS-micro controller of the latest generation H8-300L with extremely low current consumption operating at a voltage as from 1.8 V. The temperature measuring circuit with automatic self-calibration measures the discharging time of a capacitor. The accuracy of the measuring circuit is independent of the supply voltage.

2.1.6 Versions

- Heat cost allocator INDIV-X-10V with optical interface, standard device
- Heat cost allocator INDIV-X-10VT with optical interface, remote sensor device with 1.5 m cable

- Radio heat cost allocator INDIV-X-10W with optical interface, standard device
- Radio heat cost allocator INDIV-X-10WT with optical interface, remote sensor device with 1.5 m cable.

2.1.7 Optical Interface

With a standardised optical probe the consumption and configuration values can be transferred directly to a computer. With the radio heat cost allocator INDIV-X-10W all consumption values can thus be readout over the optical interface and over radio. The data are transmitted in M-bus-format acc. to EN1434. Authorised personnel can alter the configuration of the device over the optical interface with an optical probe.

2.1.8 Radio Transmission

The radio heat cost allocator INDIV-X-10W features a transceiver circuit in the 433 MHz band with integrated antenna. With the radio system, proven since more than 10 years; it is possible to readout the consumption values via a mobile radio modem or via a radio central installed directly in the office. The radio system is a bidirectional system, i.e. the radio heat cost allocator is only called from a mobile PDA or a radio central upon request to send its data. It is a great advantage that this system allows the alteration of the parameters over radio.

Installation Guide Electronic Heat Cost Allocator INDIV-X-10V, INDIV-X-10W Radio

2. Specification

2.2 Operating mode

2.2.1 Cycle Time

The heat cost allocators INDIV-X-10V / INDIV-X-10W operate in a cycle of 4 minutes. Most of the time, the device is in sleeping mode. Every 4 minutes the device is set into operation and operates according to the adjoining diagram.

The clock-pulse generator is a counter which is completely independent from the rest of the programme. This counter is designed in a way so that it is impossible to stall the cycle or to skip one or more cycles.

Each cycle follows the adjoining diagram. The measuring and calculating processes are explained in detail later.

The tasks carried out during one cycle are taking approx. 200 ms. This means that the device is in sleeping mode more than 99.8 % of the time. It can be set into operation between two cycles over the optical probe or by pushing the button. In this case it carries out the requested task and then returns to sleeping mode.

In case an optical probe is connected or the button is pushed during the course of the cycle, the respective value is readout at the end of the cycle.

The button can be pushed for an indefinite period of time and the optical probe can be left in its position since the normal function of the device is not impaired by an influence from outside.

2.2.2 Single Sensor Version with Start Sensor

The start sensor of the single sensor version serves as an ambient temperature sensor which mainly functions during the heating up period.

The start temperature is the threshold temperature of the radiator at which the device always starts to carry out energy ratings. For these ratings, the measured radiator temperature and an assumed ambient temperature of 20° C are used as calculation basis.

2.2.3 Double Sensor Version

For the double sensor version basically the same specifications apply as for the single sensor version with start sensor. However, for calculating the room temperature the real temperature, measured by the ambient temperature sensor (corrected via the corresponding radiator-dependent „Kair-value“), is used as the basis.

2.2.3.1 Heat Accumulation Mode

In order to avoid faulty measuring due to heat accumulation (e.g. in case the radiator is hidden by panels), the device switches from a defined ambient temperature (e.g. 28°C) to the one sensor mode and calculates with an ambient temperature of 20° C.

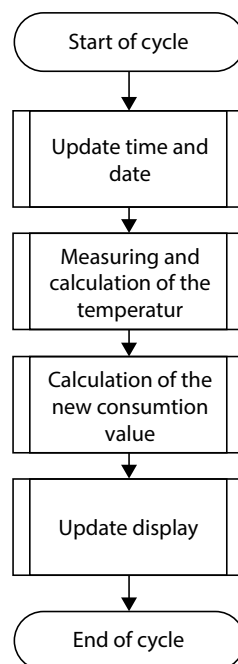

Installation Guide Electronic Heat Cost Allocator INDIV-X-10V, INDIV-X-10W Radio

2. Specification

2.2.4 Comparison of the Measuring Principles

Single sensor device with start sensor measuring principle

For heating systems with $t_{m_{min}} \geq 55 \text{ }^\circ\text{C}$

The heat cost allocator calculates with a set reference temperature of $20 \text{ }^\circ\text{C}$

Application:

Single sensor devices with start sensor are used in areas where normal ambient temperatures are given. For low temperature heating systems the double sensor device is recommended.

For radiators which are covered or blocked by fixtures, normally the single sensor devices are used because the double sensor device is not in a position to capture the current ambient temperature due to the heat accumulation.

The processes for determining the K-value for the single sensor device with start sensor and the double sensor device are identical. It is only the measuring principle that is different.

2.2.5 Temperature Measurement and Calculation

The temperature is measured with an NTC – resistor. For the resistance measurement the dis-charging time of the capacitor is measured. The measurement is carried out as follows:

2.2.5.1 Measuring of a Resistor, Principle

1. Charging of the capacitor
2. Discharging of the capacitor through the resistance which is to be measured. At the same time a 16-bit-timer starts with the discharge to measure the discharging time.
3. As soon as the voltage on the capacitor terminals reaches a certain value, an interrupt is in-duced and the timer stops. At the same time the discharging of the capacitor is stopped as well.

After the three mentioned stages, the timer provides a 16-bit-value which corresponds to the dis-charging time of the capacitor through the resistance which is to be measured. In case the resistance is known (reference resistance), the constant ratio between discharging time and resistance can be assessed.

Double sensor measuring principle

For heating systems with $t_{m_{min}} \geq 35 \text{ }^\circ\text{C}$

The heat cost allocator calculates with a variable reference temperature $T_{\text{air temperature}}$

Application:

Double sensor devices are used in areas where precise measuring of the ambient temperature is necessary and/or in low temperature heating systems.

Radiators which are covered or blocked by fixtures are detected automatically by the double sensor system which then switches over internally to the single sensor mode.

Within one billing unit, only one measuring principle (either single sensor measuring principle with start sensor or double sensor measuring principle) can be used. Mixed fitments or the use of different types of devices in the same billing unit is therefore also not allowed.

Installation Guide Electronic Heat Cost Allocator INDIV-X-10V, INDIV-X-10W Radio

2. Specification

2.2.5.2 Calculation of the Value of an Unknown Resistance (e.g. sensor resistance)

The capacitor C is loaded at constant current. The interrupt at the end of the discharge is triggered by the same threshold voltage (a fraction of the discharge voltage). If these two conditions are met, the discharge time is directly proportional to the resistance. With a reference resistance R_{ref} whose exact value is known, it is now possible to calculate the unknown resistance value R_x with the following equation:

$$\frac{t_{ref}}{R_{ref}} = \frac{t_x}{R_x} \quad R_x = \frac{t_x}{t_{ref}} R_{ref}$$

From this equation the self-calibration of the converter can be derived, which is given by measuring the discharging time through the reference resistance.

2.2.5.3 Measuring of the Radiator and Ambient Temperature

The following measurements are carried out during one cycle:

1. Measuring of the reference resistance R_{ref}
2. Measuring of the ambient temperature sensor NTC_A
3. Measuring of the radiator temperature sensor NTC_R

The measuring values are calculated with the following formula:

$$NTC_A = \frac{t_{NTC_A}}{t_{ref}} R_{ref} \quad NTC_R = \frac{t_{NTC_R}}{t_{ref}} R_{ref}$$

The reference resistance value is defined ex works with a tolerance of 0.5% with 50 ppm. The reference resistance features an excellent temperature and long-term stability.

The capacitor value and the threshold voltage have to remain stable over the whole cycle. However, they can vary at the medium- or long term without causing any failures because the self-calibration of the converter is repeated in every cycle while measuring the reference resistance.

2.2.6 Calculation of the Displayed Consumption Value

The value displayed on the heat cost allocator is calculated as follows:

Single sensor device

$$Q = K \int \left(\frac{T_H - 20}{60} \right)^{1.33} dt$$

Double sensor device

$$Q = K \int \left(\frac{T_H - T_A}{60} \right)^{1.33} dt$$

Explanation: T_H Temperature of the radiator surface in [°C]
 T_A Ambient temperature in [°C]
 Q Displayed consumption value, without unit
 K Correction factor

Unit scale: $K = 1$, set, transmitted via readout telegram 0.

Product scale: Acc. to entry $K = K_c * K_Q$

! see also in chapter 6.1.2 Rating of radiators !

Installation Guide Electronic Heat Cost Allocator INDIV-X-10V, INDIV-X-10W Radio

2. Specification

2.2.7 Start of Counting

The updating (increment) of the consumption value is carried out under the following conditions:

During winter period (heating period):

$$(T_R \geq 25\text{ °C})$$

OR

$$(T_R \geq 20\text{ °C}) \text{ AND } (T_R - T_A \geq \Delta T_{\text{MIN}})$$

During summer period (off heating period):

$$(T_R \geq 35\text{ °C})$$

OR

$$(T_R \geq 20\text{ °C}) \text{ AND } (T_R - T_A \geq \Delta T_{\text{MIN}})$$

Explanation: T_R Radiator temperature
 T_A Ambient temperature
 ΔT_{MIN} Minimum temperature difference between radiator and room
 3K for standard device (winter heating period standard setting)
 4K for remote sensor device (summer heating period standard setting)

Installation Guide Electronic Heat Cost Allocator INDIV-X-10V, INDIV-X-10W Radio

2. Specification

2.3 Display and Additional Functions

2.3.1 The Menu Sequences of the Digital Display

The menu sequences

Ex factory all menu sequences are activated. With the software INDIV-X-VISUAL-CONF the order of the menu sequences 1 - 7 can be changed in any order. However the order within the individual menu sequences 1 - 7 can-not be changed. It is also possible to hide individual menu sequences so that they are not visible to the end-user.

When reading out over the optical interface or via radio the complete set of data is always readout and transferred.

Operation of the Push Button

When pushing the button briefly the digital display always goes to the next menu sequence.

When pushing the button in one menu sequence for 2 seconds the individual values within the selected menu sequence can be accessed. When the last value within one menu sequence has been displayed, the next menu sequence can be reached by pushing the button again.

If the button is not pushed for 2 minutes, the digital display returns to the cumulated consumption value.

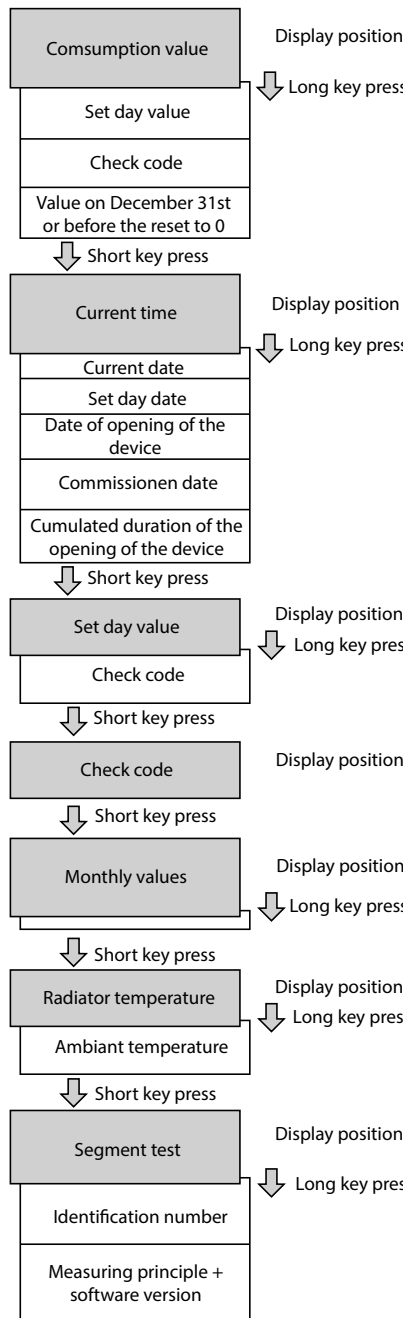
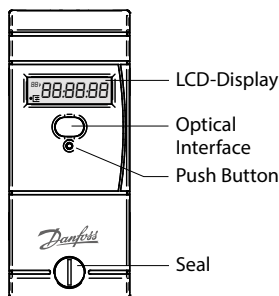

Installation Guide Electronic Heat Cost Allocator INDIV-X-10V, INDIV-X-10W Radio

2. Specification

Display loops and display menu sequences – example

The display loops and display menu sequences are customized, for example, the rolling display:

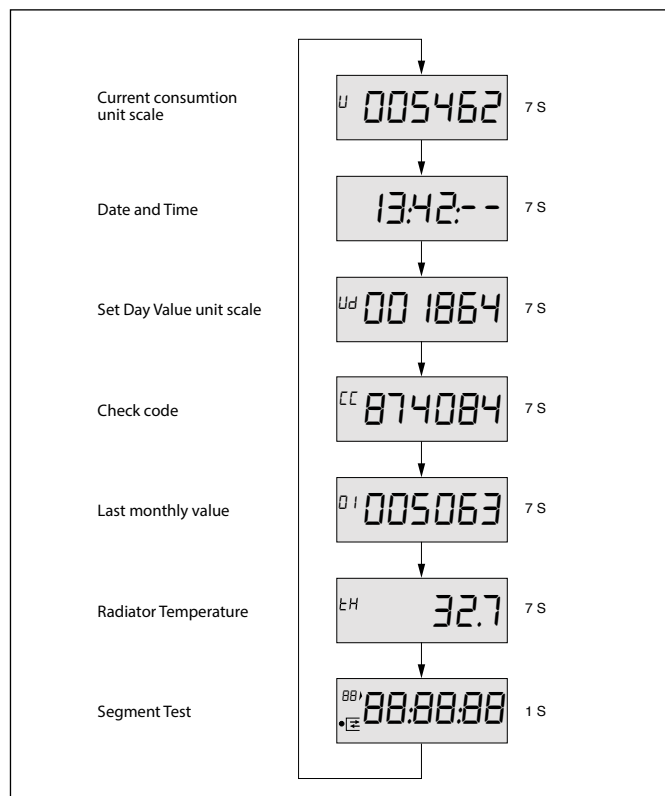

And the display menu sequences:

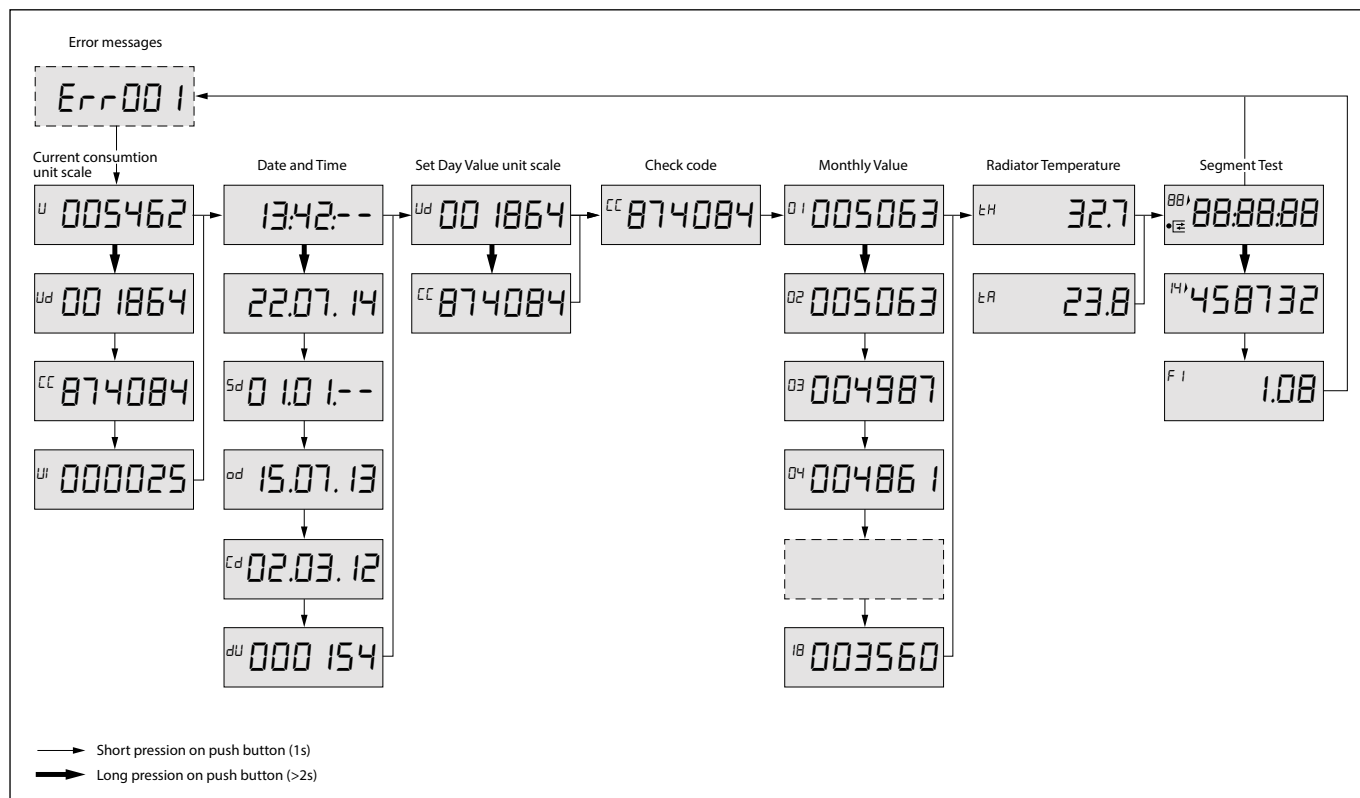

Installation Guide Electronic Heat Cost Allocator INDIV-X-10V, INDIV-X-10W Radio

2. Specification

2.3.2 The Digital Displays

During normal operation the display is deactivated and can be activated by pushing the button. On request, the heat cost allocator is also available with permanent display from 06:00 – 20:00 h or 24 hours a day. The consumption value is displayed. By pushing the button and depending on the configuration of the heat cost allocator more than 50 different values can be displayed. If the button is not pushed, the display will be active for 2 minutes only. Exception: permanent display mode.

Consumption Value Unit Scale

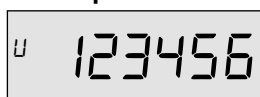

On the display of the heat cost allocator with unit scale an index **u** for unit is shown on the left side. If the index **u** is not displayed, the heat cost allocator is equipped with the product scale.

Consumption Value Product Scale

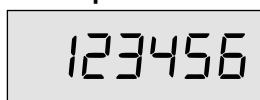

When commissioning the device this value is 000000. When reaching the value 999999, the counting restarts automatically at 000000.

Set Day Value

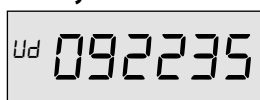

With the index **ud** the consumption value in unit scale recorded at midnight of the set day is displayed.



If a new device has not yet reached the programmed set day, 000000 is displayed.

Set day Value product scale

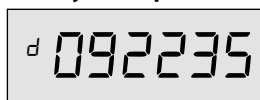

With the index **d** the consumption value in product scale recorded at midnight of the set day is displayed.



If a new device has not yet reached the programmed set day, 000000 is displayed.

Check Code

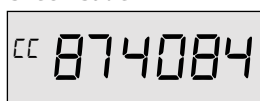

With the index **cc** the check code for the plausibility check of the manual readout is displayed.

Consumption Value of the Previous Heating Period

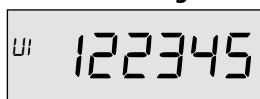

With the index **ui** the consumption value is displayed which was recorded on December 31st or before the reset to zero.



000000 is displayed on a new device as long as a reset has not been carried out.

Time

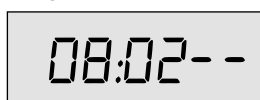

The current time (**always winter time**)

Installation Guide Electronic Heat Cost Allocator INDIV-X-10V, INDIV-X-10W Radio

2. Specification

Date



The current date of the heat cost allocator

Set Day



It is possible to program an annual set day on which the cumulated consumption value as well as the maximal radiator temperature are recorded. With the index **Sd** the programmed annual set day is displayed.

Date of Opening of the Device

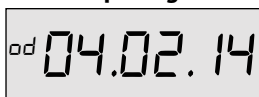

Each heat cost allocator is equipped with a manipulation protection which detects an unauthorised opening of the device after installation to the radiator. The date of the opening of the device is recorded and displayed with the index **od**.

Commissioning Date



With the index **cd** the commissioning date is displayed, i.e. the date on which the device has been activated by pushing the button or the date of commissioning programmed ex factory.

Cumulated Duration of the Opening of the Device



The cumulated duration in minutes during which the device was opened is detected. This display turns up only after commissioning in case the heat cost allocator was opened or removed.

Identification Number



With the index **7** an 8 digit identification number is displayed. Ex factory the serial number is identical with the identification number. The first two digits of the identification number are the two small digits on the left upper side of the digital display.

Monthly Values

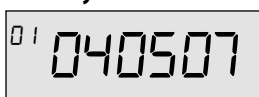

The cumulated consumption values are recorded automatically at midnight on the last day of each month. Number of monthly values: 18 or 36

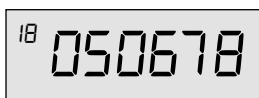

The small digits on the upper left side show the number of previous monthly values. Digit 01 stands for the recent full month and digit 18 or 36 stands for the least recent month. All monthly values are set to 000000 when the device is commissioned.

Note INDIV-X-10W radio:

The radio heat cost allocator INDIV-X-10W only transmits the first 16 monthly values via radio telegram.

Installation Guide Electronic Heat Cost Allocator INDIV-X-10V, INDIV-X-10W Radio

2. Specification

Half Monthly Values



The cumulated consumption values are recorded automatically at midnight on the 16th of each month.

The small digits on the upper left side indicate the number of half monthly values. Digit 41 stands for the recent half monthly value and digit 58 for the least recent half monthly value. All half monthly values are set to 000000 when the device is commissioned.

If the heat cost allocator INDIV-X-10V is programmed with 36 monthly values the menu sequences for the half monthly values are omitted.

Note INDIV-X-10W radio:
The heat cost allocator INDIV-X-10W does not transmit the half monthly values via radio telegram.

Radiator Temperature

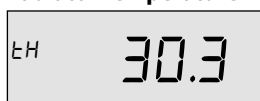

With the index **tH** the current radiator temperature is displayed.

Ambient Temperature

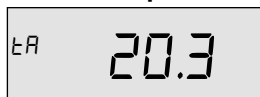

With the index **tA** the current ambient temperature is displayed.

Maximum Radiator Temperature of the Current Heating Period



With the index **P0** the maximum radiator temperature since the last reset or of the current heating period is displayed.

Maximum Radiator Temperature of the Previous Heating Period

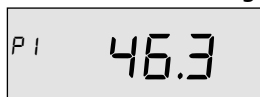

With the index **P1** the maximum radiator temperature before the last reset or of the previous heating period is displayed.

Measuring Principle and Software Version



With the index **F1** or **F2** the measuring principle is displayed.

F1 = single sensor device with start sensor

F2 = double sensor device

On the right side the software version x.xx of the heat cost allocator is displayed.

Segment Test



Segment test of the display.

Error Message



If an error is detected, **Err** is displayed in the first display sequence with the corresponding error message.

Installation Guide Electronic Heat Cost Allocator INDIV-X-10V, INDIV-X-10W Radio

2. Specification

2.3.3 Rolling Digital Display

The EHCA INDIV-X-10V and INDIV-X-10W also feature the possibility of a rolling display between 06:00 – 20:00 h. With the software INDIV-X-VISUAL-CONF it is possible to individualise the rolling display. Up to 7 parameters can be chosen optionally from the list below. These parameters can be combined in any order and are then shown on the rolling display.

- Consumption value
- Time
- Date
- Set day
- Set day value
- Last monthly value
- Last half monthly value
- Radiator temperature
- Ambient temperature
- Maximum radiator temperature of the current heating period or since the last reset
- Segment test

The duration of the display of the values can be chosen individually as follows:

- Short duration: 1 s (set, cannot be changed)
- Long duration: 2 - 7 s (only one value can be chosen)

Example:

Order and duration of display

- Pos. 0: Error (parameter ex factory, cannot be changed) [5 s]
(only displayed in case of an error message)
- Pos 1: Time [1 s]
- Pos 2: Segment test [1 s]
- Pos 3: Consumption value [4 s]
- Pos 4: Set day [1 s]
- Pos 5: Set day value [4 s]
- Pos 6: Last monthly value [1 s]
- Pos 7: Blank (therefore no display. It is not necessary to occupy all positions)

The rolling display can also be deactivated by the INDIV-X-VISUAL-CONF, i.e. the device operates as in standard menu mode except that only these values and the values of the corresponding sub-menus that have been defined in the rolling menu can be displayed by pushing the button. After 2 minutes during which the button has not been pushed, the display goes out.

Installation Guide Electronic Heat Cost Allocator INDIV-X-10V, INDIV-X-10W Radio

2. Specification

2.3.4 Energy-Saving Night Mode between 20.00 and 6.00 h

If the LCD-display is activated, the heat cost allocator switches automatically to the energy-saving night mode between 20.00 and 06.00 h (winter time). During this period the LCD-display is deactivated and switched off generally.

2.3.5 Communication Indicator

The communication indicator displays if the heat cost allocator is currently making a calculation and/or if it communicates internally or externally over the optical or wireless interface.

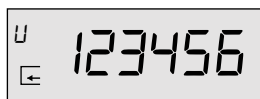

If the arrow of the communication indicator points inwardly internal communication takes place over the optical or wireless interface.

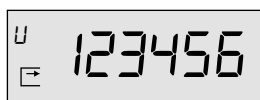

If the arrow of the communication indicator points outwards external communication takes place over the optical or wireless interface.

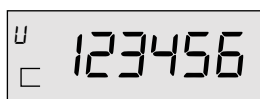

If the frame of the communication indicator appears the heat cost allocator is carrying out a measuring or a calculation.

2.3.6 Real Time Clock and Calendar

The device has a 24 h real time clock and a calendar. However, the change from summer to winter time is not taken into account. The calendar is programmed until December 31 2099, including all leap years. The real time clock as well as the date of the heat cost allocator can be readout over the optical interface or via radio and if necessary be updated.

If the current date and time have to be updated over the optical interface or via radio, it is necessary to check the date of the computer first. Date and time of the device aim at those of the computer. If the reading/programming device (computer/PDA/ Smart Phone) has a wrong time, this time will be programmed into the heat cost allocator and suddenly no longer be reached at the usual time, because the time of the heat cost allocator possibly is shifted by several hours.

Installation Guide Electronic Heat Cost Allocator INDIV-X-10V, INDIV-X-10W Radio

2. Specification

2.3.7 Readout

The current and monthly values recorded by the heat cost allocator INDIV-X-10V and INDIV-X-10W as well as several other parameters can be readout over the optical interface or also over radio with the heat cost allocator INDIV-X-10W (see description chapter 5).

The following parameters are transmitted:

- Identification number (information in header)
- Error
- Software version
- Date and time
- Consumption value
- K_c -value x K_Q -value
- Current radiator temperature
- Current ambient temperature
- Date of the opening of the housing
- Cumulated duration of the opening of the housing in minutes
- Date of commissioning
- Set day
- Set day value
- Value of previous heating period
- Maximum radiator temperature of current heating period
- Maximum radiator temperature of previous heating period
- Monthly values
- Half monthly values
- Serial number

2.3.8 Check Code

A special additional feature of the electronic heat cost allocator INDIV-X-10V is the check code function for the postcard mail-in method.

With especially developed algorithms a 6 digit check code is generated out of several device data. With this check code the values stated on the postcards mailed-in by tenants can be cross checked.

For this check

- the date
- the current consumption value
- the set day value and
- the check code

are required.

For the verification of the check code Danfoss places all necessary tools (programmes, formulas) at the disposal of the authorised personnel.

Installation Guide Electronic Heat Cost Allocator INDIV-X-10V, INDIV-X-10W Radio

2. Specification

2.3.9 Change of Battery

The battery of the heat cost allocator is soldered. The lithium battery is not rechargeable. A change of battery is not planned. Therefore the heat cost allocators have to be replaced after 10 years.

Disposal

It is mandatory to dispose of the heat cost allocator environmentally friendly or to return it after use to the manufacturer for appropriate disposal to ensure that the components are recycled in accordance with the battery and electronic scrap regulations. Should you do the disposal yourself please get information from your local authority on the recycling possibilities.



2.3.10 Protection against Outside Influences

2.3.10.1 Seal and seal sticker

The heat cost allocator is closed with a seal which cannot be removed without damaging it. Thus it is impossible to open the device unnoticed.

A seal sticker as second seal is used for further protecting against manipulation. After mounting, the seal sticker is fixed between housing of heat cost allocator and aluminium back plate. Heat cost allocator cannot be removed from aluminium back plate without damaging a sticker.

After installation, the electronic part of the device is no longer accessible. The digital display, the push button and the optical interface are covered by a sight glass. It is impossible to access the inside of the device through these openings without damaging the sight glass.

2.3.10.2 Electronic Detector in Case of an Opening of the Device

The electronic detector detects unauthorised opening, removing and closing of the heat cost allocator. As soon as the housing of the heat cost allocator is opened and/or removed, the electronic detector triggers an error message. The duration of each opening is counted, cumulated and only the last date of opening recorded.

Installation Guide Electronic Heat Cost Allocator INDIV-X-10V, INDIV-X-10W Radio

2. Specification

2.4 Special Functions

2.4.1 Suppression of Summer Counting

The period during which summer counting is suppressed can be programmed by the software.

If the heat cost allocator is in the period of summer counting suppression, consumption measuring is deactivated. If an automatic readout is carried out during this period the temperatures can be read anyway since the temperature measuring is still active.

If the special function „suppression of summer counting“ is activated, the homologation acc. to EN 834 is void. This special function is not included in the applicable standard.

2.4.2 Programmable Start Temperature of Summer and Winter period

The threshold values for the start temperature can be programmed separately for the summer and winter period within a temperature range of 25 - 40 °C in steps of 0.01°C. The respective change-over days (e.g. summer period as from May 15th and winter period as from October 15th) are also freely programmable. By separating the start temperature for the summer and winter period, it is possible to avoid a faulty energy rating due to sun exposure. If the value is below the start temperature, an energy calculation is carried out in accordance with the conditions mentioned in chapter 2.2.7.

2.4.3 Annual Reset of the Values

The function of the annual reset of the cumulated consumption value can be programmed by the software over the optical interface. One of the following dates can be chosen for the reset:

- December 31st
- Set day
- Start summer period
- Start winter period

Please note that only the cumulated consumption value is reset. All other values are not reset.

2.4.4 Unit Scale and Product Scale

For the heat cost allocators INDIV-X-10V and INDIV-X-10W, distinction is made between the unit scale and the product scale.

If heat cost allocators are used with the same scale on all radiators, this scale is called unit scale. The display values are the same on the different radiators if the heat cost allocators are exposed to the same temperature for the same period of time.

The evaluation of the display values is carried out arithmetically with the rating factors of the calculation software to receive the final consumption values.

Installation Guide Electronic Heat Cost Allocator INDIV-X-10V, INDIV-X-10W Radio

2. Specification

2.4.4.1 Advantages of the Unit Scale

- Easy and quick installation of the heat cost allocator, no programming necessary
- Possible errors by doing the scaling on site are avoided due to allocation by experts.

With the product scale, the radiator rating data are programmed in the heat cost allocator on site. The overall rating factor K_{total} is calculated directly in the heat cost allocator and thus the consumption value is displayed immediately.

2.4.4.2 Advantages of the Product Scale

- The actual consumption of each consuming point within one billing unit can be compared easily and quickly on site.

Installation Guide Electronic Heat Cost Allocator INDIV-X-10V, INDIV-X-10W Radio

2. Specification

2.5 Parameterisation

With the software INDIV-X-VISUAL-CONF the following parameterisations can be carried out over the optical interface:

Parameterisation ex factory - Example

Date and time	UTC+1 (winter time)
Set day	01.01.
Date of commissioning	deactivated
Start of summer period	May15
End of summer period	October 15
Start temperature summer period	35°C (Radiator temperature)
Start temperature winter period	25°C (Radiator temperature)
Activation of heat accumulation mode summer period	35°C (Maximum ambient temperature)
Activation of heat accumulation mode winter period	28°C (Maximum ambient temperature)
Double sensor measuring principle	activated
Single sensor measuring principle with start sensor	deactivated
Reset to zero of consumption value	deactivated
Suppression of summer counting	deactivated
Unit scale	activated §
Product scale	deactivated
Rating factor KC	1.0 §
Rating factor KQ	1.0 §
36 monthly values	activated
18 monthly and 18 half monthly values	deactivated
Check code	activated
Identification number	identical with serial number
Digital display	deactivated
Menu sequences	all
Rolling display	activated
Sleeping mode	activated
Cold counting	deactivated

§ Unit scale → $K_c = K_q = 1.0$ displayed in the telegramme as $K_c * K_q = 1.0$

With the software INDIV-X-VISUAL-CONF it is also possible to reset all recorded consumption values as well as all error messages. Furthermore, the device can also be reprogrammed from operation to sleeping mode.

2.6 Error

2.6.1 Description of the Function Control

After a hardware reset and before each measuring the microcontroller carries out a self-test. In case an error is detected, the corresponding error-bit in the RAM is set and the respective error message is displayed on the digital display. After 4 minutes a reset is carried out (before the next measuring) and the recorded error-bit in the RAM is deleted automatically. If after the reset the error is detected again, the corresponding error-bit in the RAM is also set and the respective error message is displayed on the digital display.

Installation Guide Electronic Heat Cost Allocator INDIV-X-10V, INDIV-X-10W Radio

2. Specification

2.6.2 List of Errors

- Err.001 Manipulation (fraud) ! Disabled with remote sensor version !
- Err.002 Measuring error
- Err.008 Only INDIV-X-10W: error EEPROM, error of radio communication
- Err.016 Error of digital display – the data to be processed cannot be displayed
- Err.032 Button pushed constantly
- Err.064 Measured temperature not within temperature range (0..105°C; 0..120°C remote sensor). Cable of remote temperature sensor are in contact (short-circuited).
- Err.066 Cable of remote temperature sensor are not in contact.

2.7 Radio Standby – Radio-HCA INDIV-X-10W

In order to achieve a user-friendly and power-saving radio standby, the radio heat cost allocator features the following different operating modes:

2.7.1 Sleeping Mode

Ex factory the radio heat cost allocator INDIV-X-10W is in sleeping mode, but the internal clock and the date are running.

Current consumption is reduced to a minimum since no measuring and no calculations are carried out and furthermore communication options are not assisted.

Transition from sleeping to installation mode is achieved by pushing the button once or by reaching the programmed commissioning date.

2.7.2 Installation Mode

During the installation mode all functions of the radio heat cost allocator are carried out and radio transmission is possible for max. 24 hours. This guarantees an optimal availability of the radio heat cost allocator for test purposes during installation.

The radio heat cost allocator remains in installation mode until midnight and then switches over automatically to operation mode.

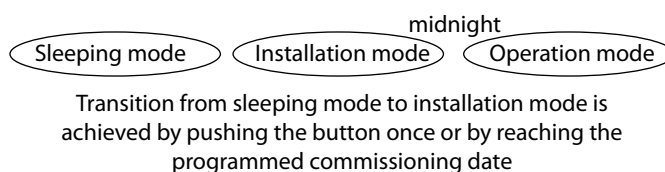

Installation Guide Electronic Heat Cost Allocator INDIV-X-10V, INDIV-X-10W Radio

2. Specification

2.7.3 Operation Mode

2.7.3.1 Walk-By Radio Remote Readout

A walk-by remote readout of the data of the heat cost allocator INDIV-X-10W is possible every day from 6.00 to 17.58 (winter time).

No readout possible between 18.00 and 20.00 (winter time)!

2.7.3.2 Readout over Radio Central (installed directly in the building)

For the readout over a radio central installed in the building, the following applies (see table below):

The device with the corresponding final numeral of the serial number is ready for radio transmission during the time stated in the table below.

Time	Serial Number
20:00 – 20:58	XXXXXXXX0
21:00 – 21:58	XXXXXXXX1
22:00 – 22:58	XXXXXXXX2
23:00 – 23:58	XXXXXXXX3
00:00 – 00:58	XXXXXXXX4
01:00 – 01:58	XXXXXXXX5
02:00 – 02:58	XXXXXXXX6
03:00 – 03:58	XXXXXXXX7
04:00 – 04:58	XXXXXXXX8
05:00 – 05:58	XXXXXXXX9

After readout of the data from the radio heat cost allocator, the radio availability is deactivated again.

Installation Guide Electronic Heat Cost Allocator INDIV-X-10V, INDIV-X-10W Radio

3. Installation

3.1 Introduction

To guarantee the proper functioning of the heat cost allocator INDIV-X-10V and INDIV-X-10W, it is of great importance that it is installed by an expert. On one hand, a constant heat transfer between radiator and heat cost allocator has to be guaranteed. On the other hand, the installation of the heat cost allocators to a large variety of radiator types should be as easy as possible.

The installation can be carried out in two different ways. The standard device is installed directly to the radiator. For the wall-mounted version the remote sensor is installed to the radiator and the heat cost allocator is wall-mounted. For the installation of the heat cost allocators, special fastening-parts kits are available. To avoid faulty installation, we also recommend reading the Kc-data in the data base prior to the installation.

The heat cost allocator is an electronic device which – like all other similar devices – has to be handled with care. It is sensible to electric discharge and contacting certain areas of the PCB. Electric discharge can destroy the device or – even worse – damage it in a way that it fails after an indefinite period of time.

For this reason it is essential to avoid contact with the PCB.

3.2 DIN Standard Requirements for the Installation

- a. Heat cost allocators can be installed in heating systems where the mean design heating medium temperature is between the upper operating temperature limit t_{max} and the lower operating temperature limit t_{min} (t_{max} and t_{min} are stated in the technical data, see enclosure)
- b. The installation of the devices has to be durable and safe against manipulation.
- c. The devices have to be installed in a place where sufficient correlation between the displayed value and the heat output of the radiator is given over a maximum operating range.
- d. Within one billing unit (in case of pre-distribution of the energy consumption: within one users' group) only heat cost allocators of the same make and the same type with identical rating systems may be used. Each device type has to be identifiable as such.
- e. Combinations of radiators and heat cost allocators with a measured value of $c > 0.3$ in basic condition are not permitted. In exceptional cases c -values of up to 0.4 are permitted within one billing unit if the concerned heating surface does not exceed 25 % of the overall heated surface or if the mean design heating medium temperature is above 80°C. Heat cost allocators may only be installed to radiators where the c -value is known at the time of billing.

Installation Guide Electronic Heat Cost Allocator INDIV-X-10V, INDIV-X-10W Radio

3. Installation

3.3 General Restrictions

Electronic heat cost allocators cannot be used with steam heating, floor heating, ceiling radiant heaters and flap-controlled radiators.

In case of combined valve- and flap-controlled radiators, the installation of an electronic heat cost allocator is only permitted if the flap control is dismantled or shut down in position „open“.

Convector heaters where the performance can be altered by an electric blower as well as heat towel racks with an electric heating cartridge may only be equipped with an electronic heat cost allocator if the additional electric attachments are dismantled or shut down.

3.4 Operating Range

The heat cost allocators can be used in heating systems with the following mean heating medium temperatures:

For single sensor devices with start sensor

55°C...105°C for standard heat cost allocator

55°C...120°C for wall-mounted heat cost allocator (remote sensor)

For double sensor devices

35°C...105°C for standard heat cost allocators

55°C...120°C for wall-mounted heat cost allocators (remote sensor)

A heat cost allocator can be used in heating systems where the suitability of the system is in line with the operating conditions for which the heat cost allocator has been approved.

The diagram in the enclosure 1 should be used to check if the heating system is in line with the operating range.

Please refer to standard EN 834 (excerpt in enclosure 3) for the definition of the terms.

Installation Guide Electronic Heat Cost Allocator INDIV-X-10V, INDIV-X-10W Radio

3. Installation

3.5 Installation to the Radiator

The heat cost allocator is always installed in the middle of the overall length ($0,5 \times BL$) of the radiator at a height of $\frac{3}{4}$ of the overall height ($0,75 \times BH$) measured from the bottom to the small round whole in the middle.

If the height of the radiator is less than (<) 470 mm, the heat cost allocator must be installed at 50% BH.

If the radiator has an even number of sections the heat cost allocator is installed between the middle sections. If the radiator has an uneven number of sections the device is installed next to the valve-sided middle section.

When welding the heat cost allocator the upper threaded bolt has to be welded from the bottom side in the middle of the overall length ($0,5 \times BL$) and at a height of $(0,75 \times BH) + 2 \text{ cm}$. The lower bolt is positioned vertically 5 cm below the upper bolt and welded. Before welding the lacquer has to be removed from the welding points. Attention has to be paid that the bolts are welded onto a water-bearing area or a flute. **Only use M3 bolts with a maximum length of 8 mm** or there's a risk that the device will be damaged. Mount the back plate through the 2 oval holes, adjusted to the top edge of the 2 ovals holes.

If the radiator is of a length of more than 3 m, two heat cost allocators have to be installed. This radiator is thus regarded as two series connected individual radiators which however are individually.

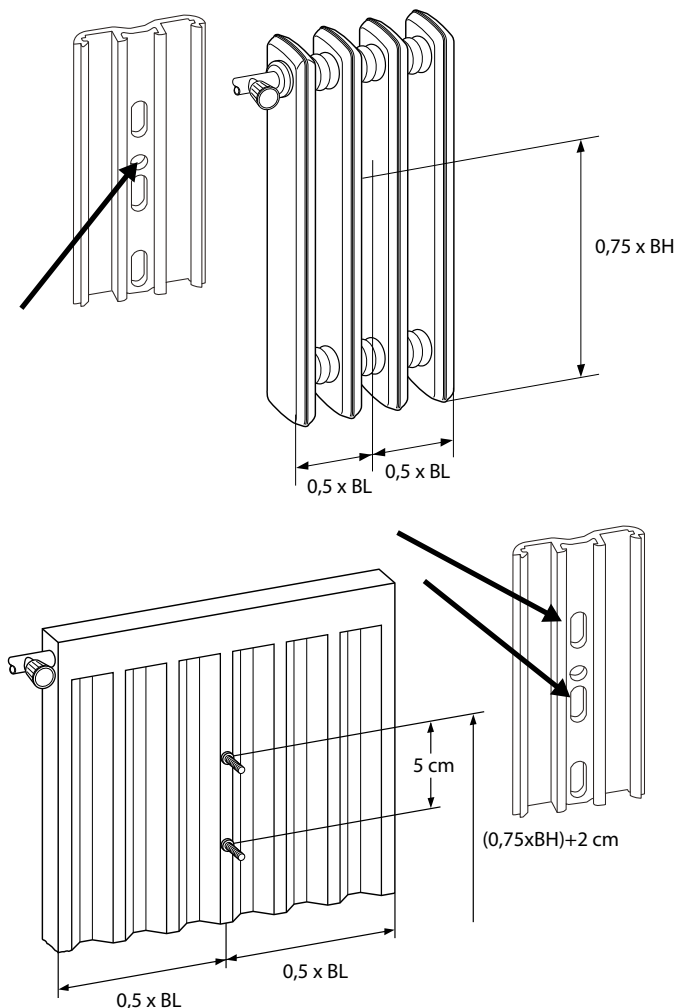

Example of 2 heat cost allocators

Mounting: $0,75 \times BH + 2 \text{ cm}$ to the upper bolt

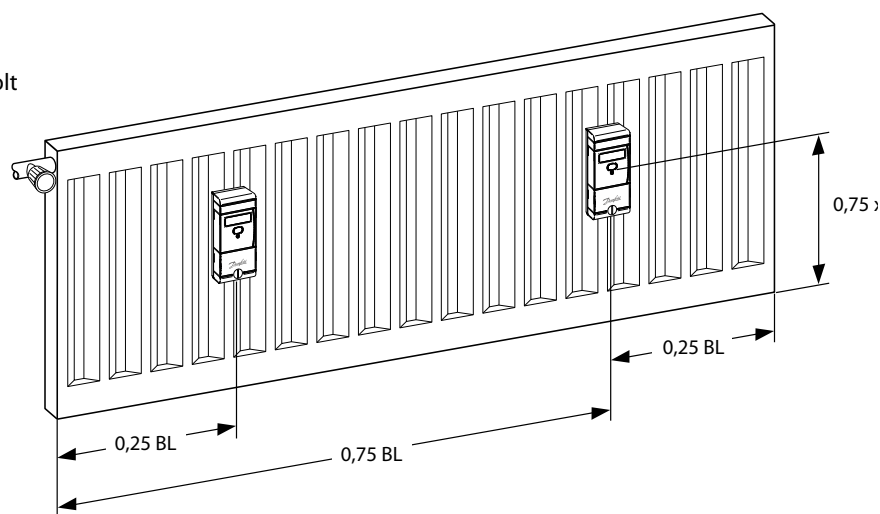

Installation Guide Electronic Heat Cost Allocator INDIV-X-10V, INDIV-X-10W Radio

3. Installation

3.6 Wall-Mounting

The heat cost allocator has to be wall-mounted if the overall height of the radiator is less than 250 mm or if, for aesthetical reasons, the heat cost allocator cannot be mounted directly onto the radiator.

In this case, the heat cost allocator is wall-mounted on the side opposite to the valve and at a minimum distance from the radiator of 10 cm.

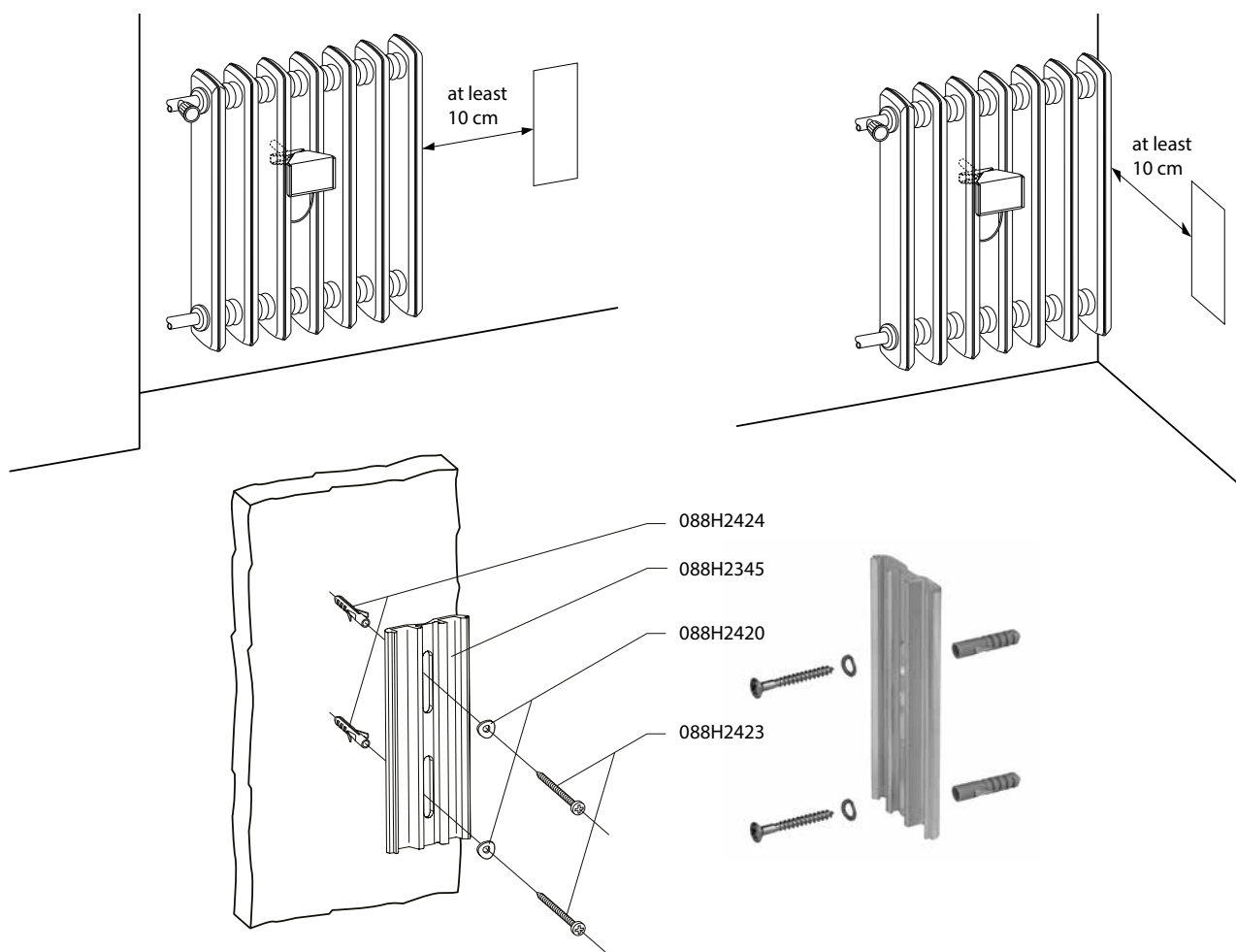

- After marking and drilling the holes, the aluminium profile is fastened with 2 metal screws and 2 spring washer.
- The parts necessary for the wall-mounting are included in the corresponding fastening-parts kits for the installation of the remote sensor.
- After installation of the device to the wall and the sensor to the radiator, the sensor cable is laid in a cable duct.
- Mount the back plate through the 2 oval holes adjusted to the top edge of the 2 oval holes.

Mounting Accessories	Code No.
2 plastic dowels Ø5 mm 3.25	088H2424
1 aluminium back plate (supplied with EHCA)	088H2345
2 spring washers	088H2420
2 oval head wood screws 3 x 35	088H2423

Installation Guide Electronic Heat Cost Allocator INDIV-X-10V, INDIV-X-10W Radio

3. Installation

3.7 Installation of Fastening-Parts Kits

3.7.1 Installation to Sectional Radiator

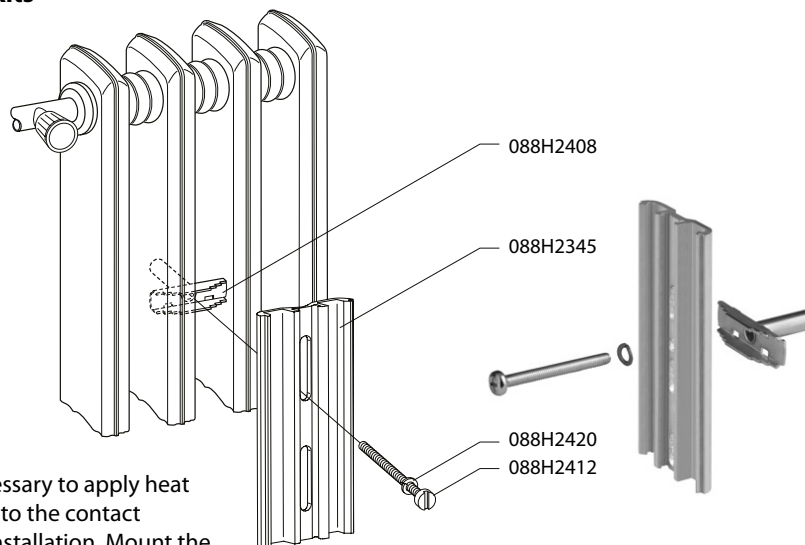

- For radiators made from cast iron it is necessary to apply heat transfer compound (**Electrolu-be HTS**) onto the contact surfaces of the aluminium profile before installation. Mount the back plate through the little hole in the middle.

Mounting Accessories	Code No.
1 tensioning bracket	088H2408
1 aluminium back plate (supplied with EHCA)	088H2345
1 cylinder head screw M4 x 40	088H2412
1 spring washer B 4	088H2420

3.7.2 Wall-Mounting - Sectional Radiator

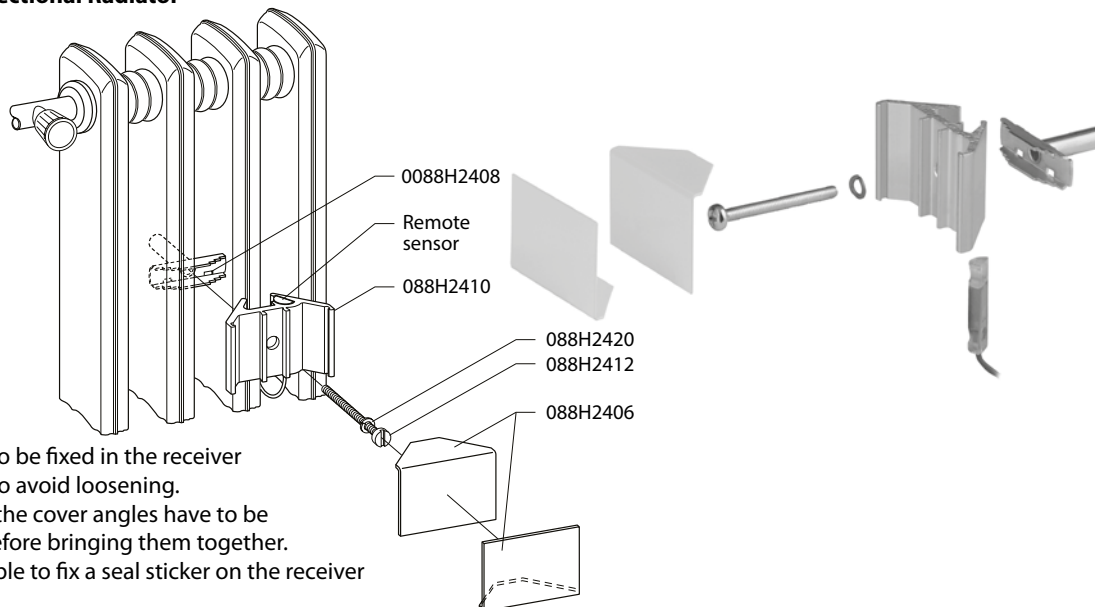

- The remote sensor has to be fixed in the receiver housing with adhesive to avoid loosening.
- The contact surfaces of the cover angles have to be coated with adhesive before bringing them together.
- After mounting, it is possible to fix a seal sticker on the receiver housing.

Mounting Accessories	Code No.
1 tensioning bracket	088H2408
1 aluminium profile „receiver housing“	088H2410
1 spring washer B 4, DIN 128	088H2420
1 cylinder head screw M4 x 40 (with crosshead)	088H2412
2 cover angles, white	088H2406
2 plastic dowels Ø5 mm 3.25 (wall)	088H2424
2 oval head wood screws 3 x 35 (wall)	088H2423

Installation Guide Electronic Heat Cost Allocator INDIV-X-10V, INDIV-X-10W Radio

3. Installation

3.7.3 Installation to Folded Radiator

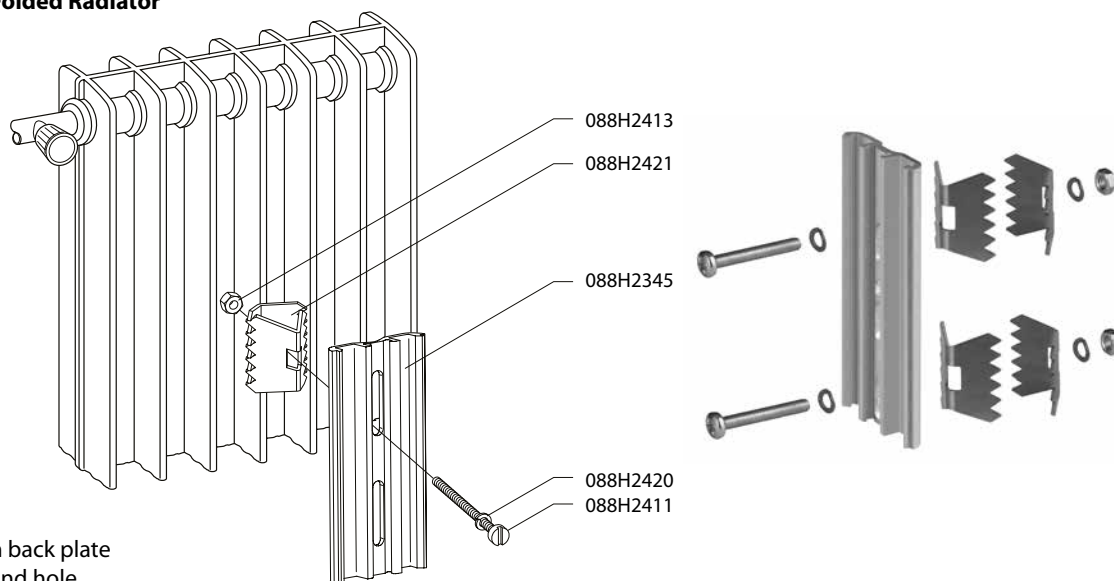

- Mount the aluminium back plate through the small round hole

Mounting Accessories	Code No.
1 hexagon nut B M4, DIN 934	088H2413
2 bracing angles	088H2421
2 spring washers B4, DIN 128	088H2420
1 oval head screw M4 x 30	088H2411
1 aluminium back plate (supplied with EHCA)	088H2345

- If necessary use 2 x 2 bracing angles to improve more stability (photo) and, if needed, short the screw

Mounting Accessories	Code No.
2 hexagon nut B M4, DIN 934	088H2413
2 x 2 bracing angles	088H2421
4 spring washers B4, DIN 128	088H2420
2 oval head screw M4 x 30	088H2411
1 aluminium back plate (supplied with EHCA)	088H2345

Installation Guide Electronic Heat Cost Allocator INDIV-X-10V, INDIV-X-10W Radio

3. Installation

3.7.4 Wall-Mounting – Folded Radiator

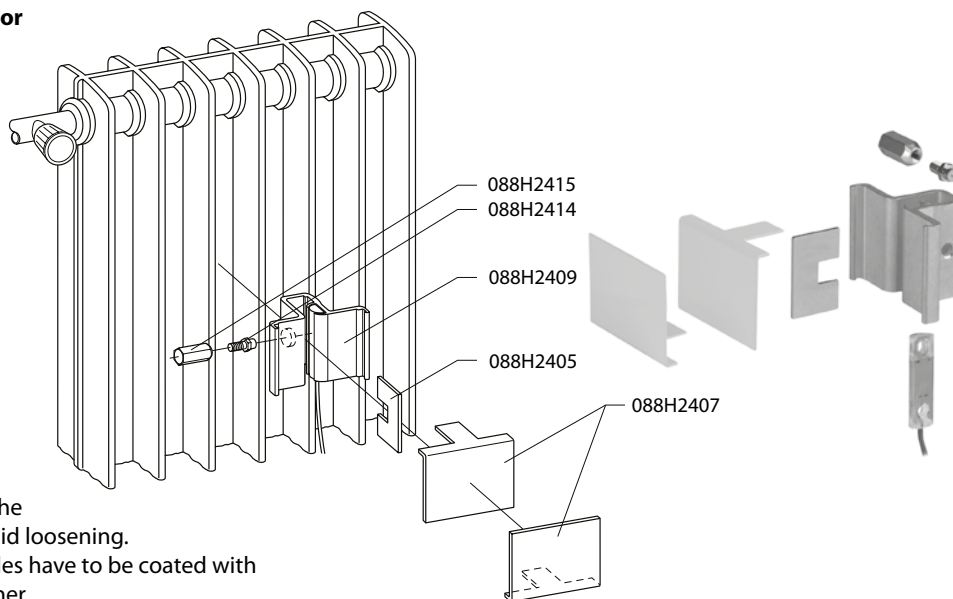

- The remote sensor has to be fixed in the receiver housing with adhesive to avoid loosening.
- The contact surfaces of the cover angles have to be coated with adhesive before bringing them together.
- After mounting, it possible to fix a seal sticker on the receiver housing.

Mounting Accessories	Code No.
1 tensioning nut	088H2415
1 tensioning bolt	088H2414
1 aluminium profile « receiver housing»	088H2409
1 safety plate	088H2405
2 cover angles, white	088H2407
2 plastic dowels Ø5 mm 3.25 (wall)	088H2424
2 oval head wood screws 3 x 35 (wall)	088H2423

Installation Guide Electronic Heat Cost Allocator INDIV-X-10V, INDIV-X-10W Radio

3. Installation

3.7.5 Installation to Panel-Type Radiator

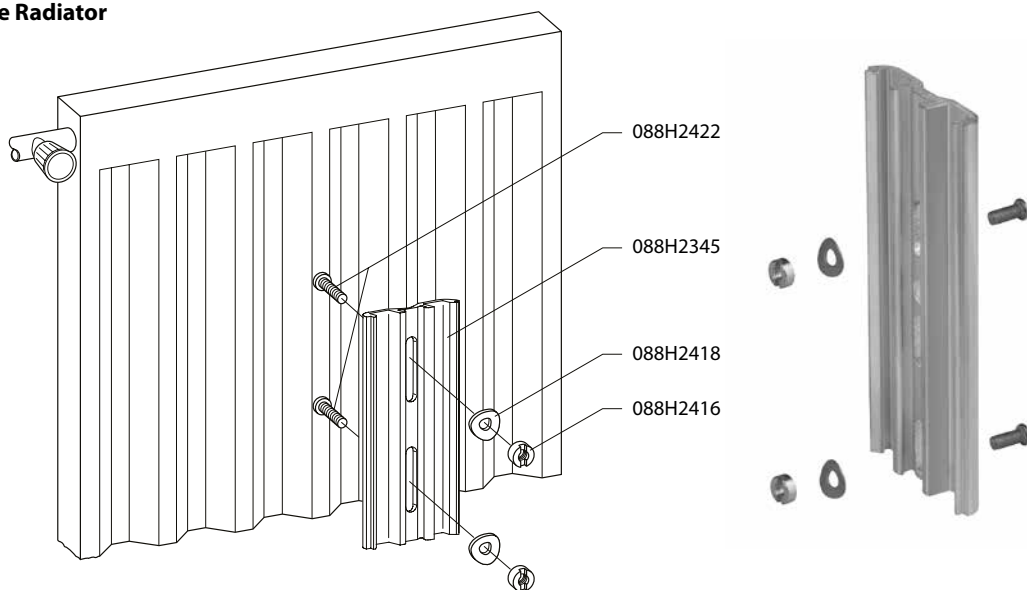

- Mount the back plate through the 2 oval holes adjusted to the top edge of the 2 oval holes

Mounting Accessories	Code No.
2 threaded bolts M3 x 8 (see page 27!)	088H2422
2 spring washers B3, DIN 137	088H2418
2 slotted nuts M3, DIN 546	088H2416
1 aluminium back plate (supplied with EHCA)	088H2345
Tool: Screw driver size 5 for M3	

or

Mounting Accessories	Code No.
2 threaded bolts M3 x 8 (see page 27!)	088H2422
2 Nuts M3 6-kant size 5.5 with flange	088H2345
1 aluminium back plate (supplied with EHCA)	088H2345
Tool: Socket wrench hexagonal size 5.5	

or

Mounting Accessories	Code No.
2 threaded bolts M3 x 8 (see page 27!)	088H2422
2 Nuts M3 mit 6-kant size 5.5	088H2345
1 aluminium back plate (supplied with EHCA)	088H2345
Tool: Socket wrench hexagonal size 5.5	

Installation Guide Electronic Heat Cost Allocator INDIV-X-10V, INDIV-X-10W Radio

3. Installation

3.7.6 Wall-Mounting - Panel-Type Radiator

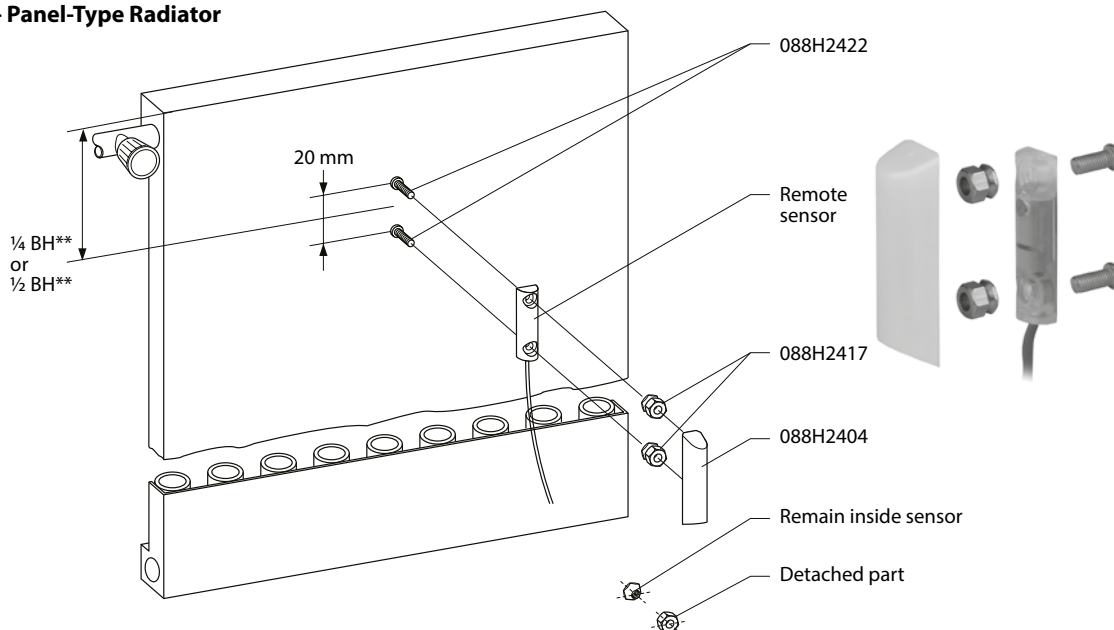

- The remote sensor has to be coated with heat transfer compound (**Electrolube HTS**) on the contact surface.
- Turn on the pull-off nuts 088H2417 till it breaks. After put on the HK-sensor cover to ensure the manipulation protection.

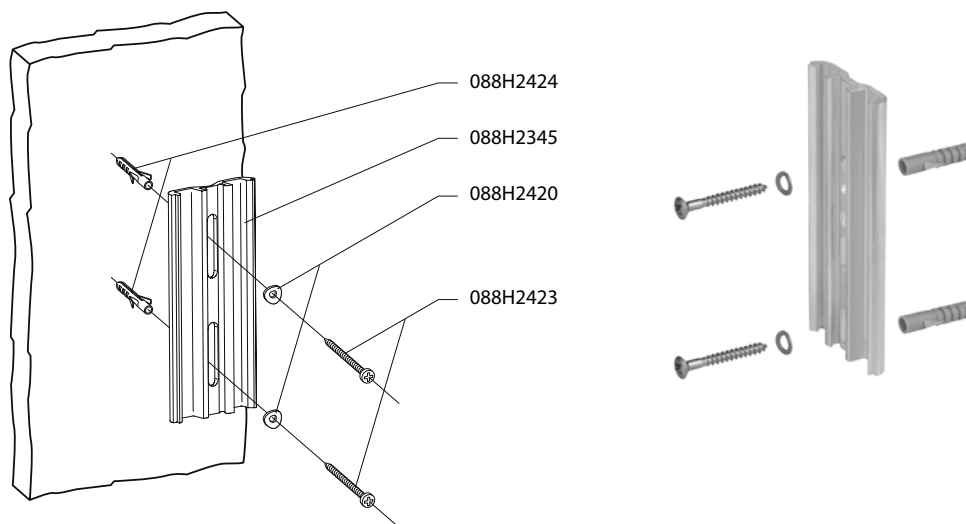

- Mount the back plate through the 2 oval holes adjusted to the top edge of the 2 oval holes

Mounting Accessories	Code No.
2 threaded bolts M3 x 8	088H2422
2 pull-off nuts M3	088H2417
1 HK-sensor cover	088H2404
2 plastic dowels Ø5 mm 3.25 (wall)	088H2424
2 oval head wood screws 3 x 35 (wall)	088H2423

Installation Guide Electronic Heat Cost Allocator INDIV-X-10V, INDIV-X-10W Radio

3. Installation

3.7.7 Installation to Panel-Type Radiator with Front Convection Plate

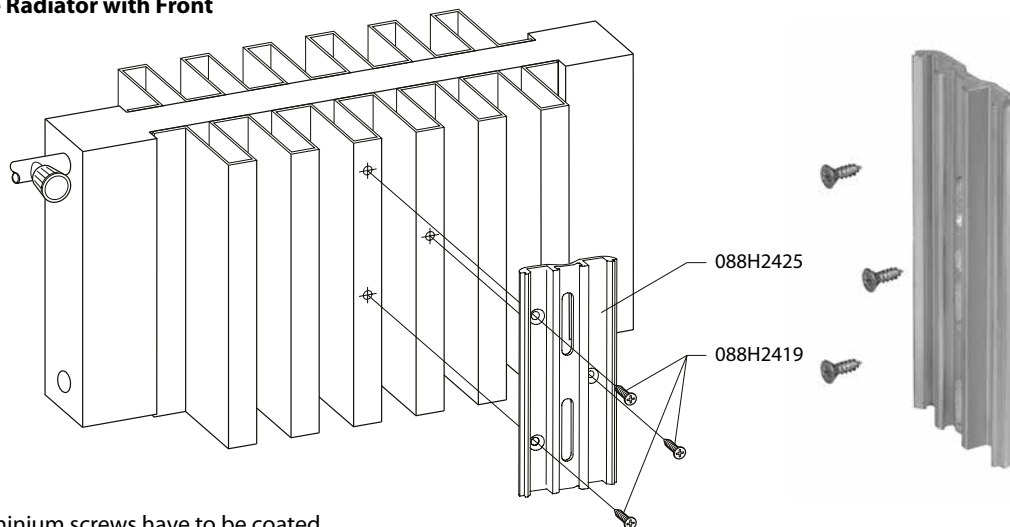

- The contact surfaces of the aluminium screws have to be coated with heat transfer compound (**Electrolube HTS**).
- The aluminium screws have to be fastened with adhesive to avoid loosening.

Mounting Accessories	Code No.
3 sheet-metal screws 2.9 x 9.5	088H2419
1 aluminium back plate	088H2425

Installation Guide Electronic Heat Cost Allocator INDIV-X-10V, INDIV-X-10W Radio

3. Installation

3.7.8 Bathroom radiator – Towel rails

Heat cost allocator mounted vertically on distributor or collector part

- Assembly with 2 threaded bolts welded on 75% BH +50mm on the side or front of the flow distributor or return collector

Mounting Accessories	Code No.
2 threaded bolts M3 x 8 (see page 27!)	088H2422
2 spring washers B3, DIN 137	088H2418
2 slotted nuts M3, DIN 546	088H2416
1 aluminium back plate (supplied with EHCA)	088H2345
Tool: Screw driver size 5 for M3	

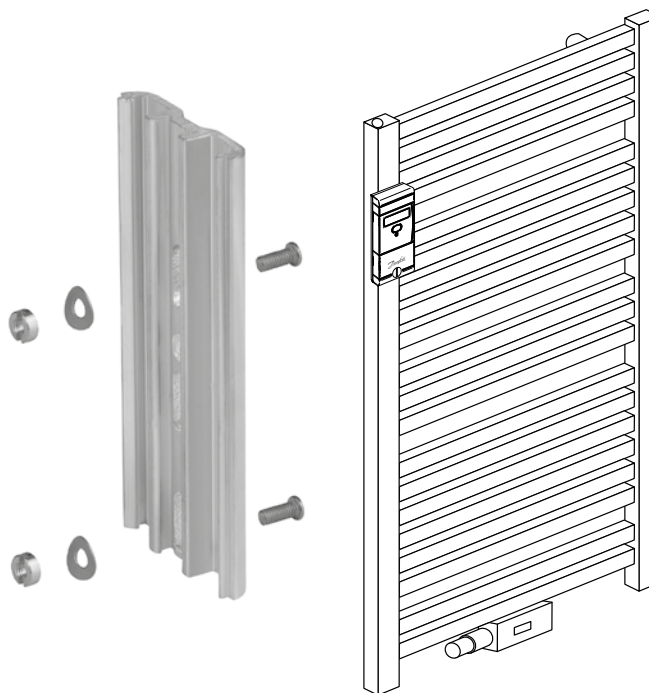

Heat cost allocator mounted horizontally on cross tubes

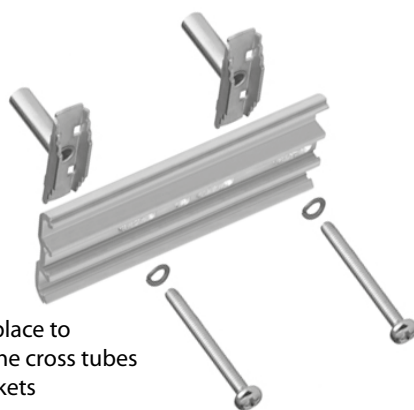

- Assembly to the nearest possible place to the flow place or return place on the cross tubes on 75% BH with 2 tensioning brackets

Mounting Accessories	Code No.
2 tensioning bracket	088H2408
1 aluminium back plate (supplied with EHCA)	088H2345
2 cylinder head screw M4 x 40	088H2412
2 spring washer B 4	088H2420

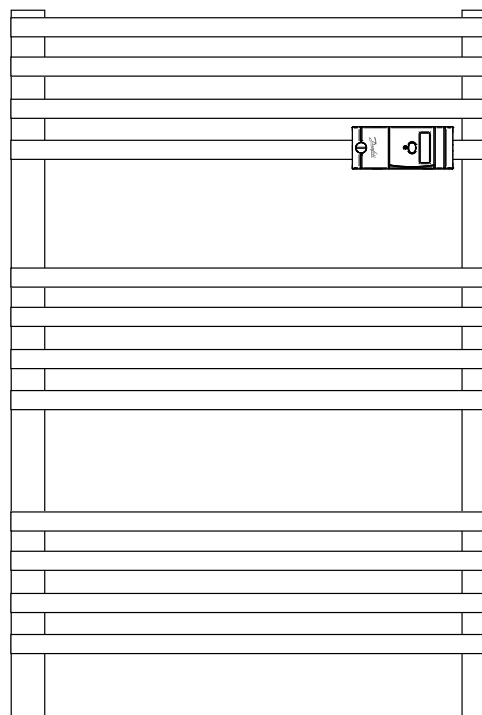

Installation Guide Electronic Heat Cost Allocator INDIV-X-10V, INDIV-X-10W Radio

3. Installation

3.7.9 Sectional radiator wide

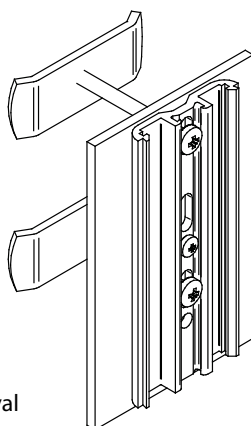

- Mount the back plate through the 2 oval holes adjusted to the top edge of the 2 oval holes

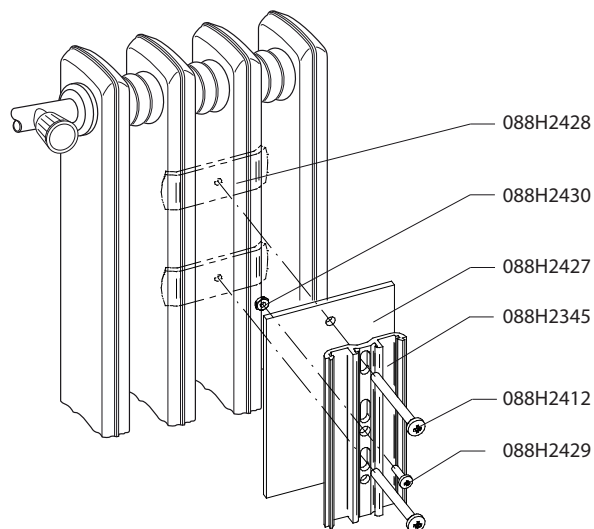



Mounting Accessories	Code No.
2 tensioning bracket 50mm	088H2428
1 aluminium back plate (supplied with EHCA)	088H2345
1 heat conductor aluminium plate 60mm	088H2427
2 cylinder head screw M4 x 40	088H2412
1 cylinder head screw M3 x 10	088H2429
1 Nut M3	088H2430

Installation Guide Electronic Heat Cost Allocator INDIV-X-10V, INDIV-X-10W Radio

3. Installation

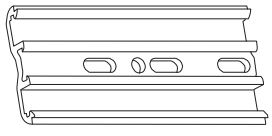
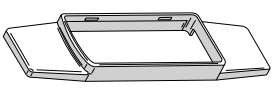
3.8 Overview mounting accessories

Code No.	Designation	
088H2400	Replacement seal 1000 pieces	
088H2345	Aluminium back plate	
088H2401	Plastic blind cover	
088H2402	Optical head USB	
088H2403	Bracket for Opto-probe	
088H2404	Cover for sensor	
088H2405	Safety plate	
088H2406	Cover angles, white , Sectional radiator (Protection plate white radiator with sections)	
088H2407	Cover angles, white , Folded radiator (Protection plate white corrugated radiator)	
088H2408	Tensioning bracket (Angle bracket)	
088H2409	Aluminium profile « receiver housing» (Aluminium plate case support for corrugated radiator)	
088H2410	Aluminium profile « receiver housing» (Aluminium plate case support for sectional radiator)	
088H2411	Raised head screw M4 x 30	
088H2412	Pan head screw 4 x 40	
088H2413	Hexagon Nut B M4, DIN 934	
088H2414	Pins	
088H2415	Tensioning nut	
088H2416	Slotted nuts M3, DIN 546	
088H2417	Two-nuts M3	
088H2418	Spring washers B3, DIN 137	
088H2419	Tapping screw 2,9 x 9,5	
088H2420	Spring washers	
088H2421	Angle spreader	
088H2422	Headless pins M3 x 8	
088H2423	Crosshead wood screws 3 x 35	
088H2424	Plastic screw plug Ø5 mm 3.25	
088H2425	Aluminium plate case support for front plate radiator	
088H2427	Heat conductor aluminium plate 60mm	
088H2428	Angle bracket 50mm	
088H2429	Cylinder screw M3 x 10	
088H2430	Nut M3	

Installation Guide Electronic Heat Cost Allocator INDIV-X-10V, INDIV-X-10W Radio

3. Installation

3.9 Mounting and Sealing

After installation of the respective fastening-parts kit to the radiator, the heat cost allocator can be mounted and sealed as described below.

1. The heat cost allocator is placed at the upper end of the aluminium back plate. Move the heat cost allocator down so that the hooks in the housing fit in the aluminium back plate.

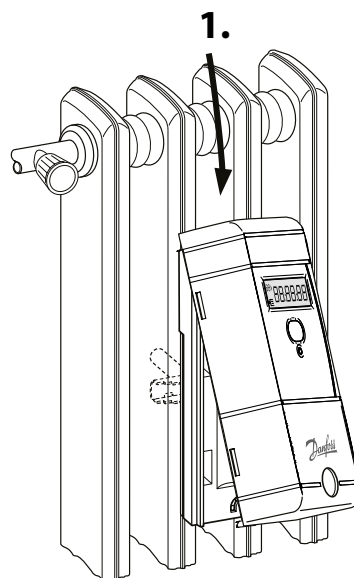

2. The heat cost allocator is swung on the aluminium back plate in the direction of the arrow.

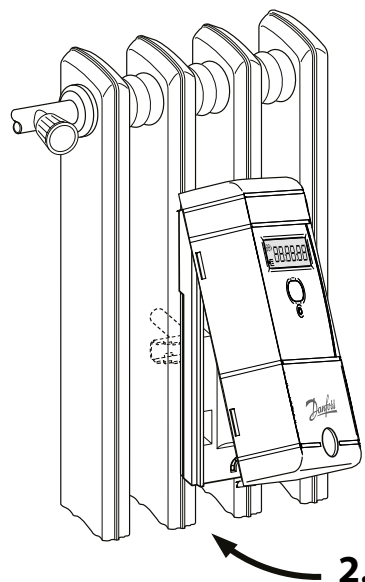

3. Introduce the seal in the slot of the housing, then press until the seal clicks into the aluminium back plate.

Now the heat cost allocator can only be opened by destroying the seal.

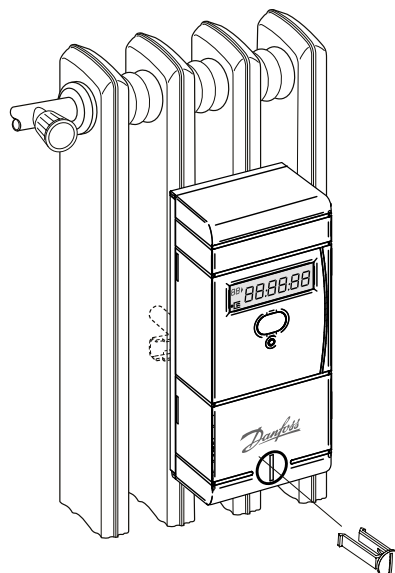

Installation Guide Electronic Heat Cost Allocator INDIV-X-10V, INDIV-X-10W Radio

4. Commissioning

Ex factory the heat cost allocators INDIV-X-10V and INDIV-X-10W are in the so-called sleeping mode. In this mode no measuring is carried out and thus no consumption values are calculated. Furthermore the digital display, the communication options as well as the device opening detection are deactivated.

The date and time are running in the background.

The measuring mode is set off by pushing the button or when reaching the programmed commissioning date.

Heat cost allocator INDIV-X-10W: in addition to the measuring mode, the installation mode is activated as well. During installation mode the radio transmission is possible for max. 24 hours.

After the commissioning and before leaving a new site, we recommend to perform a radio read out test and to create an installation protocol, to ensure that all the radio communication between the heat cost allocators and the radio central or radio modem was successful.

After midnight the radio heat cost allocator INDIV-X-10W changes automatically from installation to operation mode.

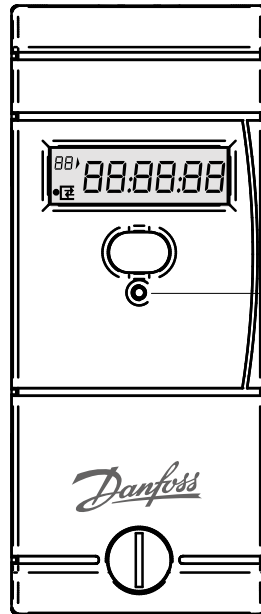

The measuring mode is set off by pushing the button (> 2 s) or when reaching the programmed commissioning date.

Installation Guide Electronic Heat Cost Allocator INDIV-X-10V, INDIV-X-10W Radio

5. Readout

5.1 Manual Readout

The recorded consumption values can be displayed by pushing the button. (see chapter 2.3)

Then the displayed values are copied to a data collection sheet or entered into a portable data acquisition device.

5.2 Readout over the Optical Interface

All data recorded in the heat cost allocator INDIV-X-10V and INDIV-X-10W can be transmitted directly to a computer over the optical interface.

5.2.1 Optical Probe

The hardware of the optical bidirectional interface which is built in the device is in line with standard EN 61107, 9.1992, part 3.2.

The optical probe is positioned on the front side of the device in the round cavity below the display. The position of the connecting cable is irrelevant. Thus access to the device is guaranteed even under difficult conditions.

5.2.2 Transmission Protocol

The format of the transmitted data corresponds to the following standards:

- IEC 870-5
- prEN 1434, 2006, (M-BUS, CEN / TC 176) :

- 2.2 Optical interface
- 4.2 Frame formats used
- 4.4 Coding of data records
- 4.6 Variable data structure

The following table and the diagram describe the format of a transmitted data byte:

Transmission	serial, asynchronous
Connection	half duplex
Speed	2'400 / 9'600 Baud
Data	8 bit
Parity	1 bit, even
No. of stop bits	1 bit

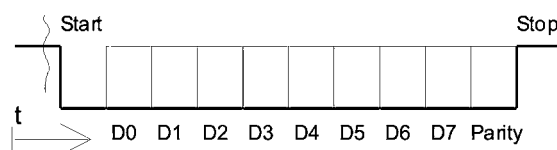

Installation Guide Electronic Heat Cost Allocator INDIV-X-10V, INDIV-X-10W Radio

5. Readout

The readout of the data can be subdivided in several stages. The following diagram describes the standard process from the point of view of the computer:

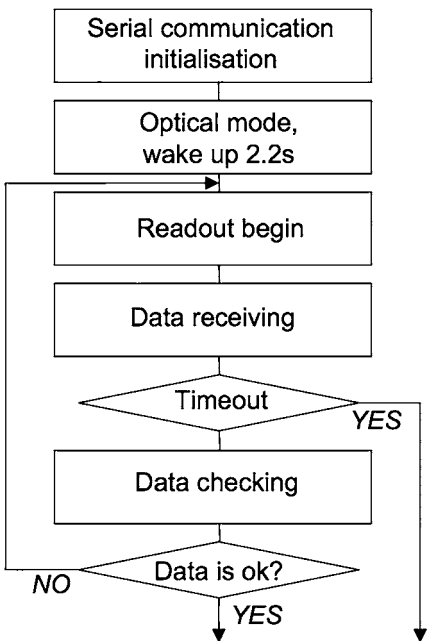

5.2.3 Timing of the Optical Interface

Radio interface: communication timings

According to standard M-Bis and EN1434-3

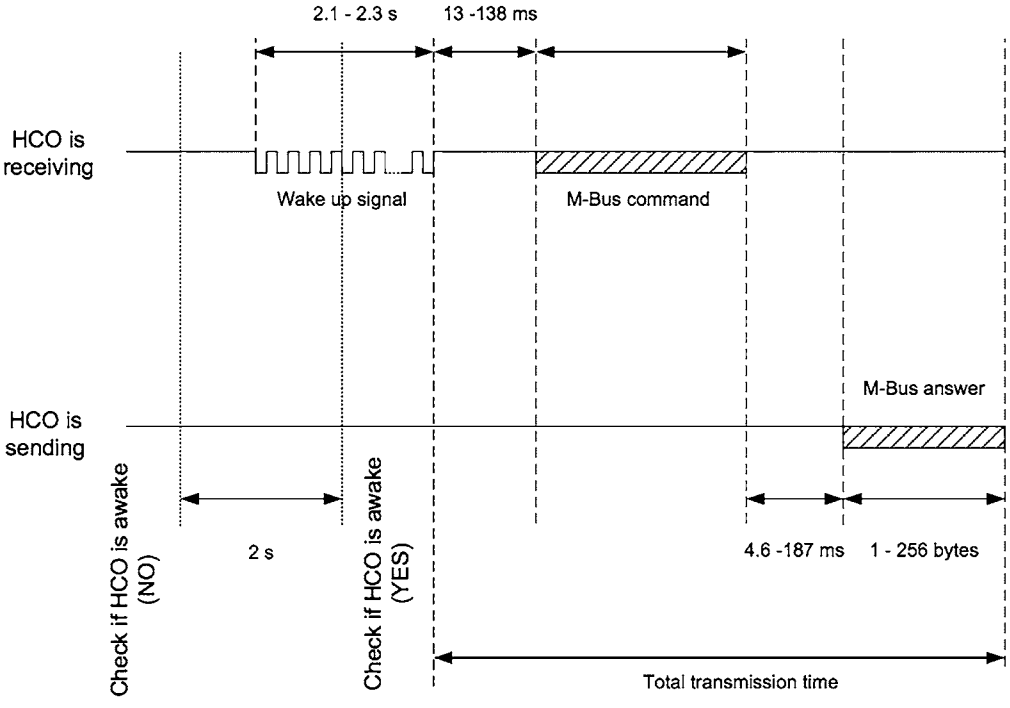

The HCO checks if a wake up signal is present every 2 seconds
 Wake up signal : 0101010101... Transmission time 2.2s +/- 0.1 s
 Total transmission time : If period is >40 s or X > 138 ms a new wake up signal is requested.

Installation Guide Electronic Heat Cost Allocator INDIV-X-10V, INDIV-X-10W Radio

5. Readout

5.2.4 Frames of the Optical Readout

The frame of the optical readout corresponds to the M-bus standard EN1434. Thus the optical interface can communicate with a M-bus standard software with the commands "request REQ_UD2" and "normalize SNP_NKE".

Frame 1:

Respond with user data RSP_UD, Variable structure response (slave to master)

Field	Frame bytes in hex	Bytes						
Header	Start_Length	68, B9, B9, 68	4	See Note 1				
	Control	08	1	Respond with user data, RSP_UD				
	Address	0	1					
	Control Information	72	1	Variable structure respond (mode 0: LSByte first)				
User Data Header			0	Coding				
	Identification number	xx xx xx xx	4	A. 32 bits				
	Manufacturer ID: "SON"	EE 4D	2	C. 16 bits				
	Version	0A	1	C. 8 bits				
	Device type	08	1	D. 8 bits HCA				
	Access number	xx	1	C. 8 bits				
	Status	xx	1	Ds. 8 bits				
	Signature (not used)	00 00	2	C. 16 bits				
				0	Coding			
					Function	Storage	Tariff	Device Unit
Flags and RSSI	02, FD 17, Fg, Fg	5	D. 16 bits		0	0	0	Error flags (LSB radio specific)
Internal version	02, FD 0F, xx xx	5	D. 16 bits		0	0	0	Other software version
Current date & time	04, 6D, xx xx xx xx	6	F. 32 bits		0	0	0	Time point; date & time
Units totalizer heating	03, 6E, xx xx xx	5	B. 24 bits		0	0	0	HCA units (dimensionless)
Units factor kC x kQ	05, EE 76, xx xx xx xx	7	H. 32 bits		0	0	0	Pulse factor (dimensionless)
Heatsink temperature	02, 59, xx xx	4	B. 16 bits		0	0	0	Heatsink Temperature 1/100 °C
Ambiant temperature	02, 65, xx xx	4	B. 16 bits		0	0	0	ambiant temperature 1/100 °C
Fraud duration	83 10, FD 31, xx xx xx	7	B. 24 bits		0	1		Duration of tariff; minute
Date of the last incrementing of the fraud duration	82 10, 6C, xx xx	5	G. 16 bits		0	1		Time point; date
Actual heatsink max. temp.	12, 59, xx xx	4	B. 16 bits	Max	0	0	0	1/100 °C
Set Day	42, EC 7E, xx xx	5	G. 16 bits		1	0	0	Set day : future date
Units totalizer stored at SD	43, 6E, xx xx xx	5	B. 24 bits		1	0	0	HCA units (dimensionless)
Heatsink max. temp. stored before zeroing	92 01, 59, xx xx	5	B. 16 bits	Max	2	0	0	1/100 °C (last period)
Units totalizer stored before zeroing	83 01, 6E, xx xx xx	6	B. 24 bits		2	0	0	HCA units (dimensionless)
Units stored at month - 1	C3 01, 6E, xx xx xx	6	B. 24 bits		3	0	0	HCA units (dimensionless)
Units stored at month - 2	83 02, 6E, xx xx xx	6	B. 24 bits		4	0	0	HCA units (dimensionless)
Units stored at month - 3	C3 02, 6E, xx xx xx	6	B. 24 bits		5	0	0	HCA units (dimensionless)
Units stored at month - 4	83 03, 6E, xx xx xx	6	B. 24 bits		6	0	0	HCA units (dimensionless)
Units stored at month - 5	C3 03, 6E, xx xx xx	6	B. 24 bits		7	0	0	HCA units (dimensionless)
Units stored at month - 6	83 04, 6E, xx xx xx	6	B. 24 bits		8	0	0	HCA units (dimensionless)
Units stored at month - 7	C3 04, 6E, xx xx xx	6	B. 24 bits		9	0	0	HCA units (dimensionless)
Units stored at month - 8	83 05, 6E, xx xx xx	6	B. 24 bits		10	0	0	HCA units (dimensionless)
Units stored at month - 9	C3 05, 6E, xx xx xx	6	B. 24 bits		11	0	0	HCA units (dimensionless)
Units stored at month - 10	83 06, 6E, xx xx xx	6	B. 24 bits		12	0	0	HCA units (dimensionless)
Units stored at month - 11	C3 06, 6E, xx xx xx	6	B. 24 bits		13	0	0	HCA units (dimensionless)
Units stored at month - 12	83 07, 6E, xx xx xx	6	B. 24 bits		14	0	0	HCA units (dimensionless)
Units stored at month - 13	C3 07, 6E, xx xx xx	6	B. 24 bits		15	0	0	HCA units (dimensionless)
Units stored at month - 14	83 08, 6E, xx xx xx	6	B. 24 bits		16	0	0	HCA units (dimensionless)
Units stored at month - 15	C3 08, 6E, xx xx xx	6	B. 24 bits		17	0	0	HCA units (dimensionless)
Units stored at month - 16	83 09, 6E, xx xx xx	6	B. 24 bits		18	0	0	HCA units (dimensionless)
More records in next telegram	80	1	Special function: start of manufacturer specific data					
Check Sum	xx	1	See Note 2					
End	16	1						

Frame size 191 bytes
Length Field 185 bytes

Installation Guide Electronic Heat Cost Allocator INDIV-X-10V, INDIV-X-10W Radio

5. Readout

Frame 2:

Respond with user data RSP_UD, Variable structure response (slave to master)

Field	Frame bytes in hex	Bytes						
Header	Start, Length	68, 9E, 9E, 68	4	See Note 1				
	Control	08	1	Respond with user data, RSP_UD				
	Address	0	1					
	Control Information	72	1	Variable structure respond (mode 0: LSB byte first)				
User Data Header			0	Coding				
	Identification number	xx xx xx xx	4	A, 32 bits				
	Manufacturer ID: "SON"	EE 4D	2	C, 16 bits				
	Generation of meter	0A	1	C, 8 bits				
	Measured media: HCA	08	1	D, 8 bits				
	Access number	xx	1	C, 8 bits				
	Status	xx	1	Ds, 8 bits				
	Signature (not used)	00 00	2	C, 16 bits				
				0	Coding			
					Function	Storage	Tariff	Device Unit
Units stored at month - 17	C3 09, 6E, xx xx xx	6	B, 24 bits		19	0	0	HCA units (dimensionless)
Units stored at month - 18	83 0A, 6E, xx xx xx	6	B, 24 bits		20	0	0	HCA units (dimensionless)
Units stored at month - 0.5 (-19)	C3 0A, 6E, xx xx xx	6	B, 24 bits		21	0	0	HCA units (dimensionless) half month
Units stored at month -1.5 (-20)	83 0B, 6E, xx xx xx	6	B, 24 bits		22	0	0	HCA units (dimensionless) half month
Units stored at month -2.5 (-21)	C3 0B, 6E, xx xx xx	6	B, 24 bits		23	0	0	HCA units (dimensionless) half month
Units stored at month -3.5 (-22)	83 0C, 6E, xx xx xx	6	B, 24 bits		24	0	0	HCA units (dimensionless) half month
Units stored at month -4.5 (-23)	C3 0C, 6E, xx xx xx	6	B, 24 bits		25	0	0	HCA units (dimensionless) half month
Units stored at month -5.5 (-24)	83 0D, 6E, xx xx xx	6	B, 24 bits		26	0	0	HCA units (dimensionless) half month
Units stored at month -6.5 (-25)	C3 0D, 6E, xx xx xx	6	B, 24 bits		27	0	0	HCA units (dimensionless) half month
Units stored at month -7.5 (-26)	83 0E, 6E, xx xx xx	6	B, 24 bits		28	0	0	HCA units (dimensionless) half month
Units stored at month -8.5 (-27)	C3 0E, 6E, xx xx xx	6	B, 24 bits		29	0	0	HCA units (dimensionless) half month
Units stored at month -9.5 (-28)	83 0F, 6E, xx xx xx	6	B, 24 bits		30	0	0	HCA units (dimensionless) half month
Units stored at month -10.5 (-29)	C3 0F, 6E, xx xx xx	6	B, 24 bits		31	0	0	HCA units (dimensionless) half month
Units stored at month -11.5 (-30)	83 80 01, 6E, xx xx xx	7	B, 24 bits		32	0	0	HCA units (dimensionless) half month
Units stored at month -12.5 (-31)	C3 80 01, 6E, xx xx xx	7	B, 24 bits		33	0	0	HCA units (dimensionless) half month
Units stored at month -13.5 (-32)	83 81 01, 6E, xx xx xx	7	B, 24 bits		34	0	0	HCA units (dimensionless) half month
Units stored at month -14.5 (-33)	C3 81 01, 6E, xx xx xx	7	B, 24 bits		35	0	0	HCA units (dimensionless) half month
Units stored at month -15.5 (-34)	83 82 01, 6E, xx xx xx	7	B, 24 bits		36	0	0	HCA units (dimensionless) half month
Units stored at month -16.5 (-35)	C3 82 01, 6E, xx xx xx	7	B, 24 bits		37	0	0	HCA units (dimensionless) half month
Units stored at month -17.5 (-36)	83 83 01, 6E, xx xx xx	7	B, 24 bits		38	0	0	HCA units (dimensionless) half month
Fabrication Number	0C, 78, xx xx xx xx	6	A, 32 bits		0	0	0	Fabrication Number BCD
Period of Units stored at 19-36	01, FD pe, nn	4	B, 8 bits		0	0	0	Storage interval in days or months
Date of the last case closure	82 20, 6C, xx xx	5	G, 16 bits		0	2	0	Time point: date
More records in next telegram	mo	1	Special function: start of manufacturer specific data					
Check Sum	xx	1	See Note 2					
Stop	16	1						

Frame size 164 bytes
Length Field 158 bytes

Installation Guide Electronic Heat Cost Allocator INDIV-X-10V, INDIV-X-10W Radio

5. Readout

5.2.5 Remote Radio Readout

5.2.5.1 General Information on the Remote Radio Readout

Danfoss expressly points out that the data transmission via mobile radio modem depends on the radio propagation conditions existing at the installation point and that under certain atmospheric or geographic conditions (especially within secluded areas as well as in so-called radio shadows) mobile radio connections cannot be established at any time and at any place. It is solely incumbent on the user to check the radio propagation conditions at the planned installation point.

5.2.5.2 Mobile Readout

The mobile radio readout of the radio heat cost allocator INDIV-X-10W is done via the mobile radio modem which is equipped with a transceiver including antenna for radio transmission. The radio modem operates at the frequency of 433.82 MHz and is combined with a PDA.

Danfoss program for the readout and parameterisation features the following main functions:

- Readout and display of an individual radio heat cost allocator
- Readout and display of a group of radio heat cost allocators
- Adding of devices in a router file
- Removing of devices in a router file
- Parameterization of an individual or a group of heat cost allocator via radio

Installation Guide Electronic Heat Cost Allocator INDIV-X-10V, INDIV-X-10W Radio

5. Readout

5.2.6 Stationary Readout

With the stationary readout, the radio central receives the data from the radio heat cost allocator or other Danfoss devices which are equipped with radio. The data recorded in the radio central can be readout over:

- Optical head
- USB
- RS-232
- M-Bus
- GSM / GPRS

Requirements : Radio central 646 are equipped with GSM/GPRS module and a GPRS subscription

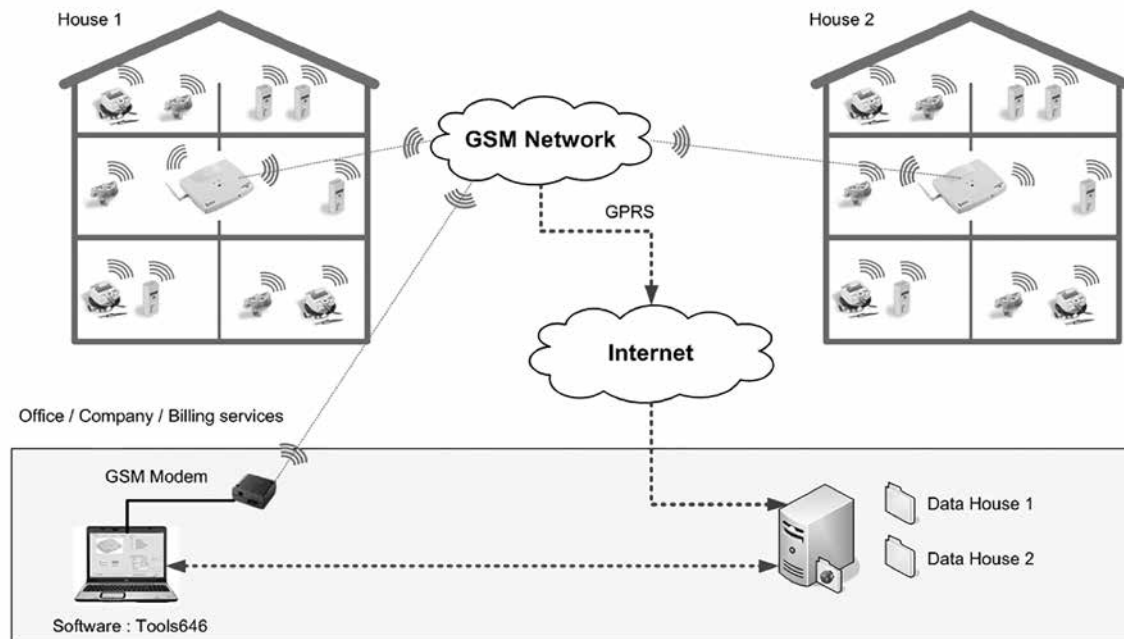

5.2.7 Timing of Radio Transmission

Radio interface: communication timings

According to standard M-Bus and EN1434-3

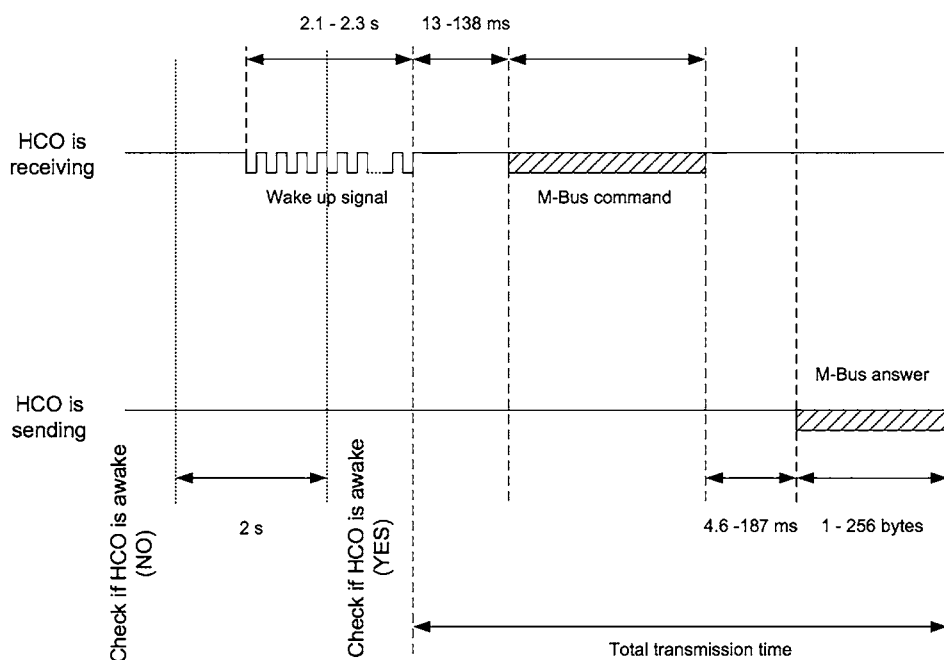

The HCO checks if a wake up signal is present every 2 seconds

Wake up signal : 0101010101... Transmission time 2.2s +/- 0.1 s

Total transmission time : If period is >40 s or X > 138 ms a new wake up signal is requested.

Installation Guide Electronic Heat Cost Allocator INDIV-X-10V, INDIV-X-10W Radio

5. Readout

5.2.8 Frame of the Radio Transmission

Respond with user data RSP_UD, Variable structure response (slave to master)

	Field	Frame bytes in hex	Bytes						
Header	Start_Length	68, B9, B9, 68	4	See Note 1					
	Control	08	1	Respond with user data, RSP_UD					
	Address	0	1						
	Control information	72	1	Variable structure respond (mode 0: LSByte first)					
User Data Header			0	Coding					
	Identification number	xx xx xx xx	4	A, 32 bits					
	Manufacturer ID: "SON"	EE 4D	2	C, 16 bits					
	Version	10	1	C, 8 bits					
	Device type	08	1	D, 8 bits				HCA	
	Access number	xx	1	C, 8 bits					
	Status	xx	1	Ds, 8 bits					
	Signature (not used)	00 00	2	C, 16 bits					
				0	Coding				
				5	D, 16 bits				
User Data Records	Flags and RSSI	02, FD 17, Eg, Eg	5	D, 16 bits		0	0	0	Error flags (LSB radio specific)
	Internal version	02, FD 0F, xx xx	5	D, 16 bits		0	0	0	Other software version
	Current date & time	04, 6D, xx xx xx xx	6	F, 32 bits		0	0	0	Time point: date & time
	Units totalizer heating	03, 6E, xx xx xx	5	B, 24 bits		0	0	0	HCA units (dimensionless)
	Units factor kC x kQ	05, EE 76, xx xx xx xx	7	H, 32 bits		0	0	0	Pulse factor (dimensionless)
	Heatsink temperature	02, 59, xx xx	4	B, 16 bits		0	0	0	Heatsink Temperature 1/100 °C
	Ambiant temperature	02, 65, xx xx	4	B, 16 bits		0	0	0	ambiant temperature 1/100 °C
	Fraud duration	83 10, FD 31, xx xx xx	7	B, 24 bits		0	1		Duration of tariff: minute
	Date of the last incrementing of the fraud duration	82 10, 6C, xx xx	5	G, 16 bits		0	1	0	Time point: date
	Actual heatsink max. temp.	12, 59, xx xx	4	B, 16 bits	Max	0	0	0	1/100 °C
	Set Day	42, EC 7E, xx xx	5	G, 16 bits		1	0	0	Set day : future date
	Units totalizer stored at SD	43, 6E, xx xx xx	5	B, 24 bits		1	0	0	HCA units (dimensionless)
	Heatsink max. temp. stored before zeroing	92 01, 59, xx xx	5	B, 16 bits	Max	2	0	0	1/100 °C (last period)
	Units totalizer stored before zeroing	83 01, 6E, xx xx xx	6	B, 24 bits		2	0	0	HCA units (dimensionless)
	Units stored at month - 1	C3 01, 6E, xx xx xx	6	B, 24 bits		3	0	0	HCA units (dimensionless)
	Units stored at month - 2	83 02, 6E, xx xx xx	6	B, 24 bits		4	0	0	HCA units (dimensionless)
	Units stored at month - 3	C3 02, 6E, xx xx xx	6	B, 24 bits		5	0	0	HCA units (dimensionless)
	Units stored at month - 4	83 03, 6E, xx xx xx	6	B, 24 bits		6	0	0	HCA units (dimensionless)
	Units stored at month - 5	C3 03, 6E, xx xx xx	6	B, 24 bits		7	0	0	HCA units (dimensionless)
	Units stored at month - 6	83 04, 6E, xx xx xx	6	B, 24 bits		8	0	0	HCA units (dimensionless)
	Units stored at month - 7	C3 04, 6E, xx xx xx	6	B, 24 bits		9	0	0	HCA units (dimensionless)
	Units stored at month - 8	83 05, 6E, xx xx xx	6	B, 24 bits		10	0	0	HCA units (dimensionless)
	Units stored at month - 9	C3 05, 6E, xx xx xx	6	B, 24 bits		11	0	0	HCA units (dimensionless)
	Units stored at month - 10	83 06, 6E, xx xx xx	6	B, 24 bits		12	0	0	HCA units (dimensionless)
	Units stored at month - 11	C3 06, 6E, xx xx xx	6	B, 24 bits		13	0	0	HCA units (dimensionless)
	Units stored at month - 12	83 07, 6E, xx xx xx	6	B, 24 bits		14	0	0	HCA units (dimensionless)
Units stored at month - 13	C3 07, 6E, xx xx xx	6	B, 24 bits		15	0	0	HCA units (dimensionless)	
Units stored at month - 14	83 08, 6E, xx xx xx	6	B, 24 bits		16	0	0	HCA units (dimensionless)	
Units stored at month - 15	C3 08, 6E, xx xx xx	6	B, 24 bits		17	0	0	HCA units (dimensionless)	
Units stored at month - 16	83 09, 6E, xx xx xx	6	B, 24 bits		18	0	0	HCA units (dimensionless)	
End	More records in next telegram	80	1	Special function: start of manufacturer specific data					
	Check Sum	xx	1	See Note 2					
	Stop	16	1						

Frame size 191 bytes
Length Field 185 bytes

Installation Guide Electronic Heat Cost Allocator INDIV-X-10V, INDIV-X-10W Radio

6. Rating factors

6.1 Taking Measurements

The value displayed by the heat cost allocator has to be converted to the value of the actual heat output of each radiator. Thereby the design and the performance of the radiator as well as the mode of installation have to be taken into account.

Therefore each radiator has to be identified precisely by taking measurements. The following data have to be established:

- Design and make of radiator
- Overall length
- Overall height
- Overall depth
- Number of sections
- Pitch
- In-line configuration

6.1.1 Rating of Radiators of Over Length or High Nominal Output

If the radiator has an overall length of approx. 3 m we strongly recommend installing two heat cost allocators.

Under certain circumstances minimal flows might not be noticed on these radiators. The same applies for radiators with an extremely high nominal output of more than 10.0000 watt = 10kW.

At least two heat cost allocators should be installed to these radiators. The standard performance of each radiator is divided by the number of heat cost allocators installed.

Example: Standard performance $K_Q = 16.000 \text{ W} = 16$
 Number of heat cost allocators installed to the radiator = 2
 $K_Q \text{ individual} = 16 / 2 = 8$

Installation Guide Electronic Heat Cost Allocator INDIV-X-10V, INDIV-X-10W Radio

6. Rating factors

6.1.2 Rating of Radiator

For each radiator type the K-value is calculated according to the following diagram:

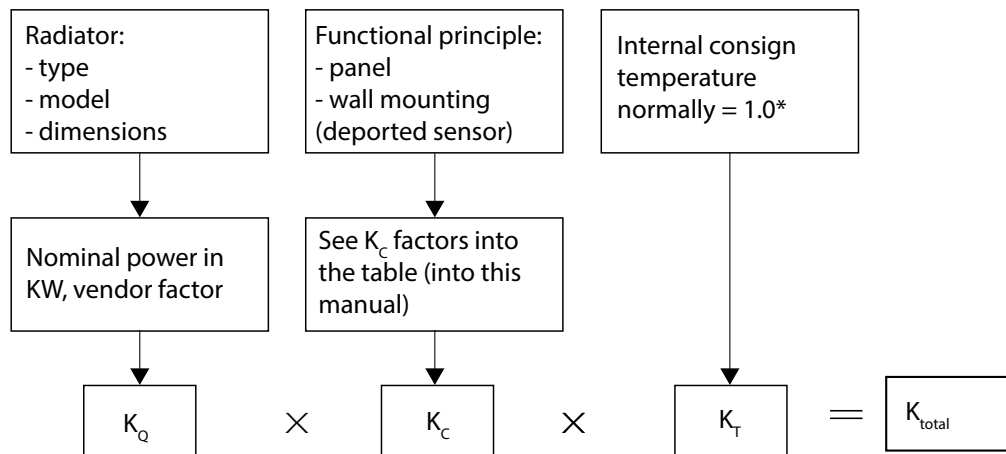

* if not, take the vendor factors

The heat cost allocator determines the heat output of the radiator, displays the consumption and records the consumption values on the set day.

The heating medium temperature is captured by the temperature sensor installed to the radiator. Thus the heat output of the radiator is calculated in consideration of the radiator performance. These calculations are started as soon as the temperature difference between ambient temperature and heating medium temperature is bigger than the parameterised value.

Out of this functional principle the necessity arises to rate the display of the heat cost allocator. For the calculation of the heat output of the radiator it is not sufficient to measure the heating medium temperature. Radiators with different performances also feature different heat output quantities even if the heating medium temperature is the same. Furthermore different designs lead to different measuring conditions for the temperature sensor installed to the radiator.

K_{Total} : Rating factor total

K_Q : Rating factor for the standard performance of the radiator, stated in KW. This value is calculated with the data received by taking measurements and the manufacturer's data.

K_C : Rating of the C-value of the radiator temperature sensor. For each type of radiator this value is measured on the test rig. The respective K_C -value can be taken from the table with the rating factors.

K_T : Rating of the design ambient temperature. Normally $K_T = 1$. For design temperatures below or equal 16°C, the respective K_T -value has to be taken from the diagram see enclosure 3.

For the definition of the rating factors according to EN 834, please see enclosure 5.

Installation Guide Electronic Heat Cost Allocator INDIV-X-10V, INDIV-X-10W Radio

6. Rating factors

6.2 Table of Rating factors

A detailed summary of the Kc-values is available in an Excel-file on request.

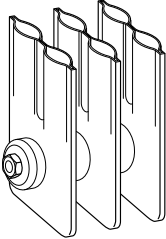
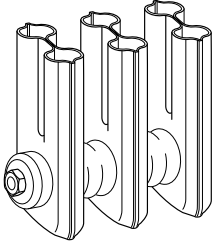
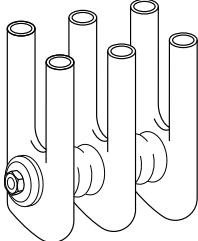
Type of Radiator	Rating factor Kc		
	Standard radiator		Wall-mounted
	2-Sensor	1-Sensor	
DIN steel radiator Distance of sections 50 mm 	2.30	1.04	1.14
DIN radiator made from cast iron Distance of sections 60 mm 	2.12	1.14	1.21
Tubular radiator (Arbonia) Distance of sections 45 mm 	2.12	1.12	1.12

Installation Guide Electronic Heat Cost Allocator INDIV-X-10V, INDIV-X-10W Radio

6. Rating factors

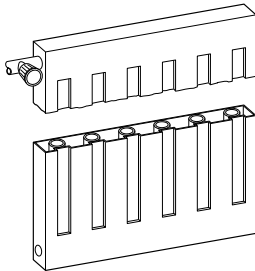
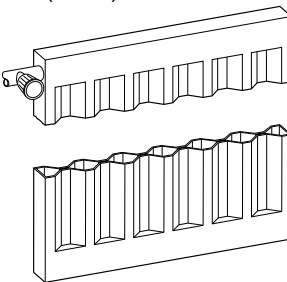
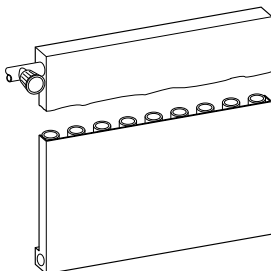
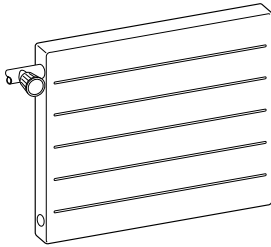
Type of Radiator	Rating factor Kc		
	Standard radiator		Wall-mounted
	2-Sensor	1-Sensor	
Radiator with internal tube register (Thermal) Pitch 60 mm 	2.19	1.10	1.05
Profile panel-type radiator, two banks (Kermi) Pitch 33 mm 	2.13	1.06	0.98
Panel-type radiator, smooth surface (Gerhar + Rau) Pitch 30 mm 	2.00	0.98	1.00
Panel-type radiator, single-bank transverse stream (Arbonia) Pitch 70 mm 	2.13	1.01	1.02

Further radiators on request

Installation Guide Electronic Heat Cost Allocator INDIV-X-10V, INDIV-X-10W Radio

7. Technical Data

Measuring system	Single-sensor with start sensor measuring system, for heating system with $t_{min} \geq 55 \text{ }^\circ\text{C}$				
	Two-sensor measuring system, for heating system with $t_{min} \geq 35 \text{ }^\circ\text{C}$				
Device versions	Compact device				
	Remote sensor device with 1.5m cable length				
Optional scales	Unit scale or product scale				
Power supply	3 V lithium battery, typical lifetime > 10 years				
Display	Liquid crystal display (LCD) with 6 digits (000000 - 999999)				
Radiator power range	4 - 16,000 W				
Sensor temperature range	0 °C - 120 °C				
Temperature sensor	NTC, prematurely aged				
Measuring principle	Area of application ¹⁾	Single-sensor with start sensor	Compact	$t_{min} = 55 \text{ }^\circ\text{C}$, $t_{max} = 105 \text{ }^\circ\text{C}$	
			Remote sensor	$t_{min} = 55 \text{ }^\circ\text{C}$, $t_{max} = 120 \text{ }^\circ\text{C}$	
		Two-sensor	Compact	$t_{min} = 35 \text{ }^\circ\text{C}$, $t_{max} = 105 \text{ }^\circ\text{C}$	
			Remote sensor	$t_{min} = 35 \text{ }^\circ\text{C}$, $t_{max} = 120 \text{ }^\circ\text{C}$	
	Start of counting	Heating period		25 °C - 40 °C (programmable)	
		Off-heating period		25 °C - 40 °C (programmable)	
Protection data	Protection class	IP52 acc. to EN60529			
Ambient conditions		Operation	Transport	Storage	
	Temperature	5...70 °C	-25...70 °C	-25...70 °C	
Norms and standards	CE Conformity according to EMC guideline - Interference resistance, emissions		EN 301 489-1, 489-3; EN 300 220-1, 220-2 EN 61000-6-3		
	Low-voltage guideline - Electrical safety		EN 60950-1		
	Heat cost allocators for the determination of the consumption of room heating radiators		EN 834		
Environmental compatibility	Product environment declaration contains		ISO 9001 (quality)		
			Directive (EC) 1907/2006 (REACH)		
Dimensions	(W x H x D)	38 x 90.5 x 28 mm			
Remote sensor cable length	1.5m				
Weight	Compact device without back plate: Ca. 42 g				
	Remote sensor device without back plate: Ca. 49 g				
	Aluminium back plate: Ca. 28 g				
Housing material	PC-ABS				
Housing colours	RAL 9010 White				

¹⁾ Definitions according to EN 834:

t_{max} Upper temperature limit. Maximum mean design heating medium temperature $t_{m,A}$ of the heating system heating surfaces equipped with heat cost allocators at which the heat cost allocator can be used.

t_{min} Lower temperature limit. Minimum mean design heating medium temperature $t_{m,A}$ of the heating system at which the heat cost allocator can be used. For single-pipe systems, the $t_{m,A}$ of the heating system is replaced by the $t_{m,A}$ of the last radiator in the string.

$t_{m,A}$ Mean design heating medium temperature. Mean value of the design flow temperature and the design return temperature.

Installation Guide Electronic Heat Cost Allocator INDIV-X-10V, INDIV-X-10W Radio

7. Technical Data

7.1 Dimensional Drawing

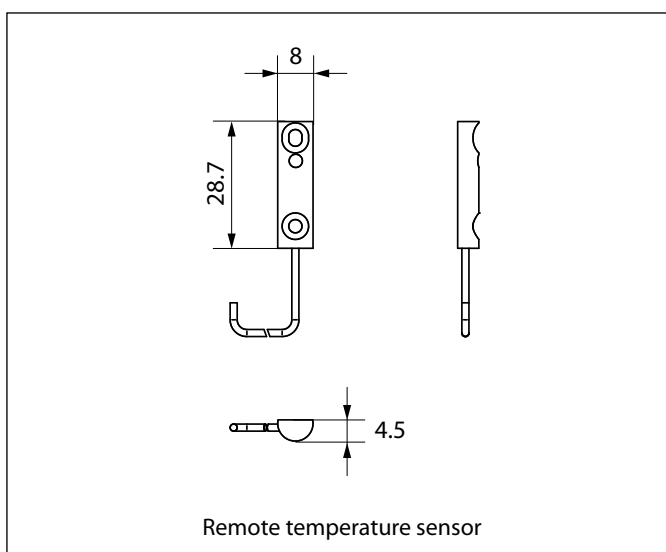
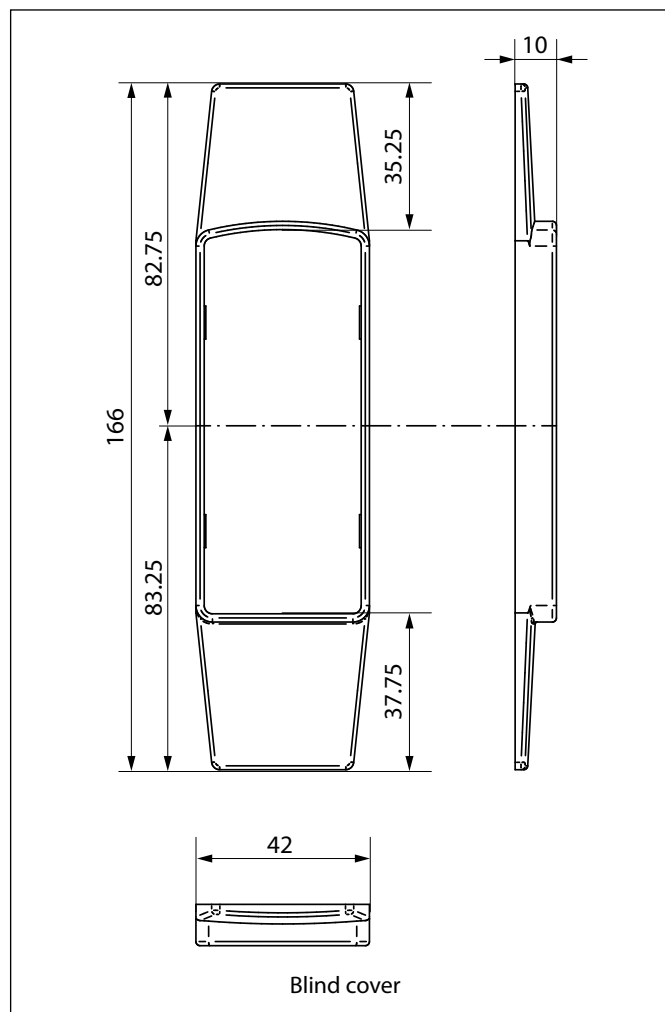
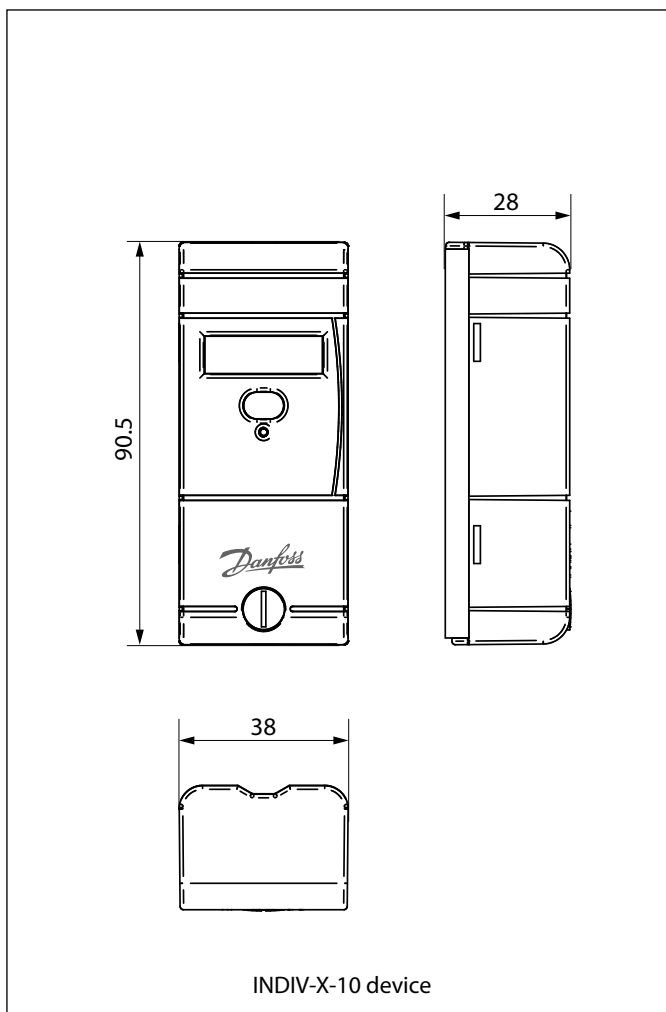

Dimensions in mm

Subject to technical change

Installation Guide Electronic Heat Cost Allocator INDIV-X-10V, INDIV-X-10W Radio

8. Enclosure

8.1 Enclosure 1

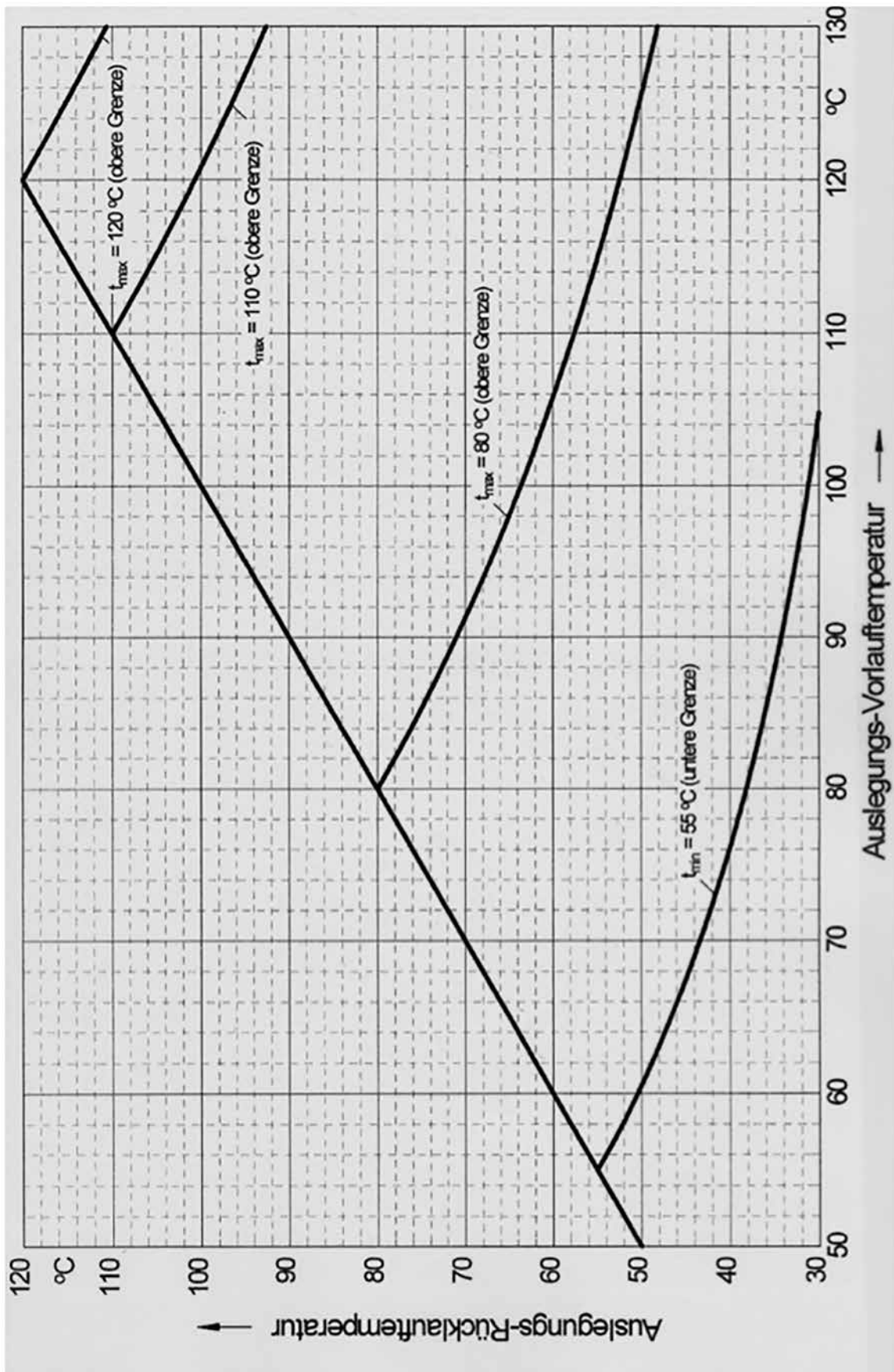

Installation Guide Electronic Heat Cost Allocator INDIV-X-10V, INDIV-X-10W Radio

8. Enclosure

8.2 Enclosure 2

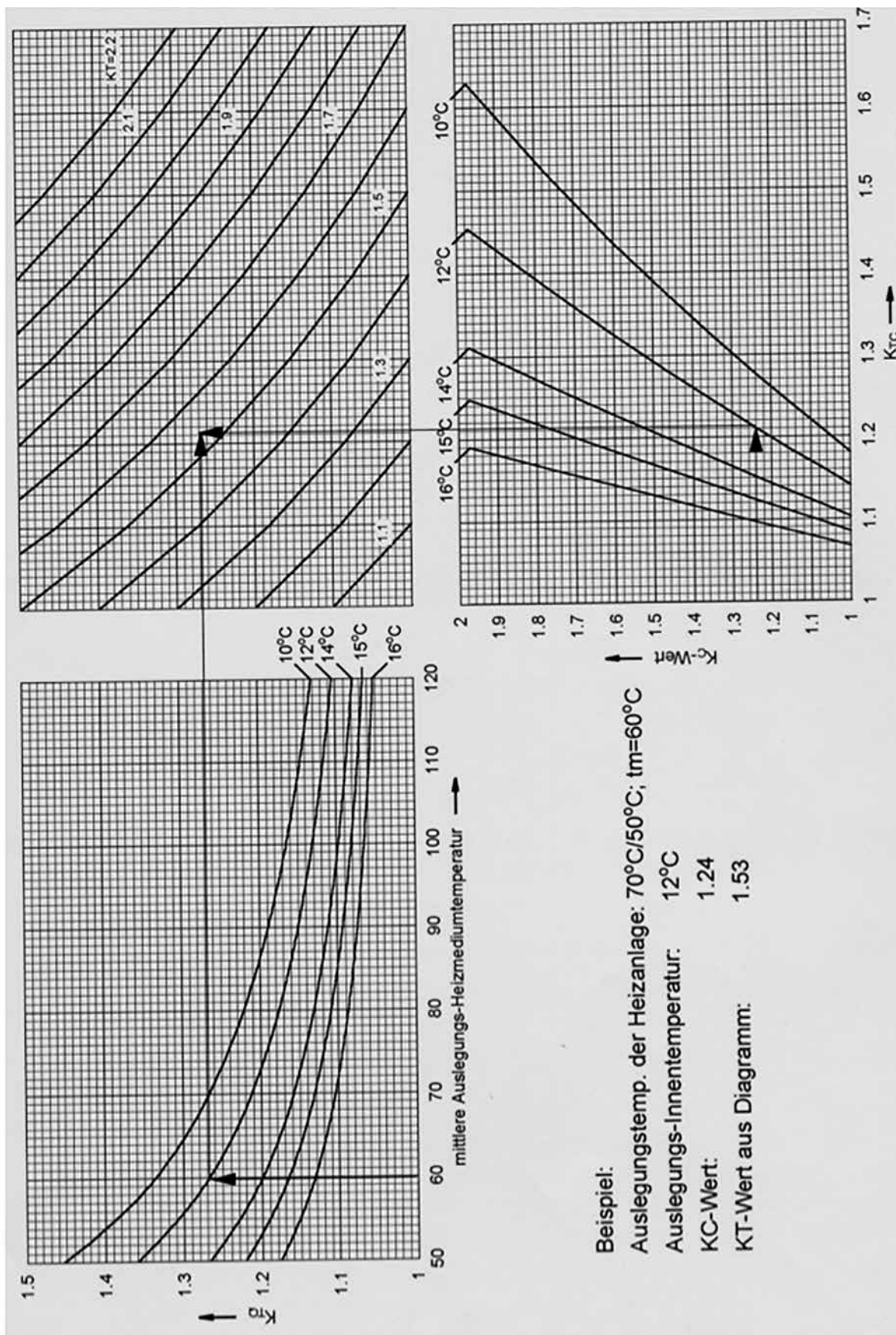

Installation Guide Electronic Heat Cost Allocator INDIV-X-10V, INDIV-X-10W Radio

8. Enclosure

8.3 Temperature Limits acc. to EN 834

Excerpt

Design flow temperature, design return temperature, mean design heating medium temperature

The design flow temperature $t_{v,A}$ and the design return temperature $t_{r,A}$ of the radiator are the temperatures of the heating medium required to reach, under stationary conditions in heated locations, the design room temperature at a heating load corresponding to a design reference outdoor temperature defined in consideration of the geographical position. The value averaged over the design flow temperature $t_{v,A}$ and the design return temperature $t_{r,A}$ equals the mean design heating medium temperature $t_{m,A}$.

Upper Temperature Limit

The upper temperature limit t_{max} is the maximum mean design heating medium temperature at which the heat cost allocator may be used.

Lower Temperature Limit

The lower temperature limit t_{min} is the minimum mean design heating medium temperature at which the heat cost allocator may be used.

Temperature Limits

Heat cost allocators which comply with this standard can be installed in heating systems where the mean design heating medium temperature $t_{m,A}$ is between the upper temperature limit t_{max} and the lower temperature limit t_{min} :

$$t_{min} \leq t_{m,A} \leq t_{max}$$

For heat cost allocators with the single sensor measuring principle:

$$t_{min} \geq 55^{\circ}\text{C}.$$

Installation Guide Electronic Heat Cost Allocator INDIV-X-10V, INDIV-X-10W Radio

8. Enclosure

8.4 Calculation of Temperature – Interpolation Table

	TREF [°C]	Slope [Ω/°C]	Offset [Ω]	Error [%]
1	0.000	15205.8	329593.0	0.00
2	4.423	11694.1	314696.0	0.43
3	8.823	9363.3	294340.6	0.51
4	12.522	7815.0	275076.6	0.46
5	15.616	6632.8	256694.2	0.70
6	18.328	5894.6	243167.3	1.20
7	20.438	5310.1	231297.4	-1.22
8	22.972	4587.6	214780.1	-0.66
9	26.063	3902.7	196973.9	-0.45
10	29.633	3216.0	176696.0	-0.44
11	34.058	2551.9	154173.9	-0.43
12	39.401	1952.3	130676.8	-0.41
13	45.709	1443.2	107549.3	-0.40
14	53.066	1026.4	85562.6	-0.44
15	61.672	707.6	66049.9	-0.38
16	71.254	472.3	49418.6	-0.37
17	82.057	305.5	35845.5	-0.35

$$T = (\text{Offset} - R) / \text{Slope}$$

Installation Guide Electronic Heat Cost Allocator INDIV-X-10V, INDIV-X-10W Radio

8. Enclosure

8.5 Rating factors acc. to EN 834

Excerpt

Rating factors

With the following rating factors the display values of each heat cost allocator can be converted into consumption values which are suitable to be used for billing the heating costs according to consumption:

Rating factor K_Q for the heat output of the radiator

The rating factor K_Q is the (non-dimensional) numerical value of the standard performance of the radiator stated in watt.

The standard performance is the heat output of a radiator in a climatic test chamber at flow-, return and ambient temperatures of 90°C, 70°C and 20°C. Here the air temperature is measured 0.75 m above the floor and in a distance of 1.5 m from the effective heating surface. If the standard performance of the radiator was determined under different temperature conditions it would have to be converted accordingly (see conditions mentioned above).

Rating factor K_c for the thermal coupling to the sensors

The rating factor K_c takes into account the different thermal couplings to the temperature sensors and the different designs of the effective heating surfaces.

K_c is the quotient out of the basic display speed and the display speed of the temperatures of the sensors which are installed to the radiators to be rated in basic condition:

$$K_c = \frac{R_{Basis}}{R_{Bewertung}}$$

Rating factor K_T for rooms with low design ambient temperatures which deviate from the basic reference air temperature

For heat cost allocators with the single sensor measuring system, the rating factor K_T takes into account the change in performance and the change in temperature of the sensors at design ambient temperatures which are lower than the reference temperature.

Overall rating factor K

The overall rating factor K is received by multiplying the individual rating factors.

$$K = K_Q \times K_c \times K_T$$

Installation Guide Electronic Heat Cost Allocator INDIV-X-10V, INDIV-X-10W Radio

Installation Guide Electronic Heat Cost Allocator INDIV-X-10V, INDIV-X-10W Radio
