

ENGINEERING
TOMORROW

Danfoss

Application guidelines

Maneurop[®] reciprocating compressors **MT/MTZ**

50 - 60 Hz

Group 2: R22, R417A, R407A/C/F, R134a, R404A / R507A, R448A / R449A, R452A, R513A

Group 1: R454A, R454C, R455A



General Information.....	4	Refrigerants and lubricants	27
Maneurop® reciprocating compressors.....	5	General information	27
Code numbers		R22	27
(for ordering)	6	Alternatives R22, HFC retrofit	27
Compressor reference (indicated on the compressor		R407C	27
nameplate).....	6	R134a	28
Compressor model designation	6	R404A.....	28
Specifications.....	7	R507A.....	28
Technical specifications.....	7	R407A.....	28
Approvals and certificates.....	7	R407F	28
Pressure equipment directive 2014/68/EU	7	R448A/R449A	28
Low voltage directive 2014/35/EU	7	R452A.....	29
Machinery directive 2014/30/EU	7	R454A/R454C/R455A.....	29
Internal free volume	7	R513A.....	29
Nominal performance data for R404A and R22	8	Hydrocarbons	29
Nominal performance data for R407C and R134a...9		System design recommendations	30
Nominal performance data for R407A and R407F.10		Piping design	30
Nominal performance data R448A/R449A and		Operating limits	31
R452A.....	11	Operating voltage and cycle rate	32
Nominal performance data R454A, R454C, R455A,		Liquid refrigerant control and charge limit.....	32
R455A and R513A.....	12	Sound and vibration management	34
Operating envelopes.....	14	Sound	34
Discharge temperature protection	18	Vibration	34
Zeotropic refrigerant mixtures	19	Installation and service	35
Phase shift.....	19	System cleanliness	35
Temperature glide.....	19	Compressor handling, mounting and connection to	
Dew temperature and Mean temperature for zeo-		the system	35
tropic mixtures	19	System pressure test	36
Outline drawings	20	Leak detection	36
1 cylinder	20	Vacuum pull-down moisture removal	36
2 cylinders	21	Start-up	37
4 cylinders	22	Ordering information and packaging.....	38
Electrical connections and wiring	23	Packaging.....	38
Single phase electrical characteristics	23		
Nominal capacitor values and relays.....	23		
Trickle circuit	23		
PSC wiring	23		
CSR wiring	23		
Suggested wiring diagrams.....	24		
Three phase electrical characteristics	25		
Winding resistance.....	25		
Motor protection and suggested wiring diagrams	25		
Soft starters.....	26		
Voltage application range	26		
IP rating.....	26		

Danfoss reciprocating compressors are designed and manufactured with state of the art technology and follow European and US regulations. There is an added emphasis placed on safety and reliability. Critical instructions are highlighted with the following icons:

 This icon indicates instructions to avoid safety risk.

 This icon indicates instructions to avoid reliability risk.

The purpose of this guideline is informational, with the intent to educate customers as to how the compressors should properly function. If you need any additional assistance, please contact Danfoss Technical Support. In any case, Danfoss manufacturing accepts no liability as a result of misuse or improper integration of the compressor unit.

Maneurop® reciprocating compressors from Danfoss Commercial Compressors are specially designed for applications with a wide range of operating conditions. All components are of high quality and precision in order to assure a long product life.

Maneurop® MT and MTZ series compressors are of the hermetic reciprocating type and are designed for medium and high evaporating temperature applications.

The positive benefits of internal motor protection, high efficiency circular valve design and high torque motors provide for a quality installation.

MT & MTZ have the same mechanical and motor design.

MT is charged with mineral oil while MTZ with polyester oil.

These compressor ranges can be used with a large choice of refrigerants according their compatibility with the oil.

MT and MTZ compressors have a large internal free volume that protects against the risk of liquid hammering when liquid refrigerant enters the compressor.

MT and MTZ compressors are fully suction-gas cooled. This means that no additional compressor cooling is required and allows the compressors to be insulated with acoustic jackets, to obtain lower sound levels, without the risk of compressor overheating.

MT and MTZ compressors are available in 16 different models with displacement ranging from 1.84 to 16.57 in³/rev. Seven different motor voltage ranges are available for single and three phase power supplies at 50 and 60 Hz. All compressors are available in VE version (oil equalisation + oil sight glass).

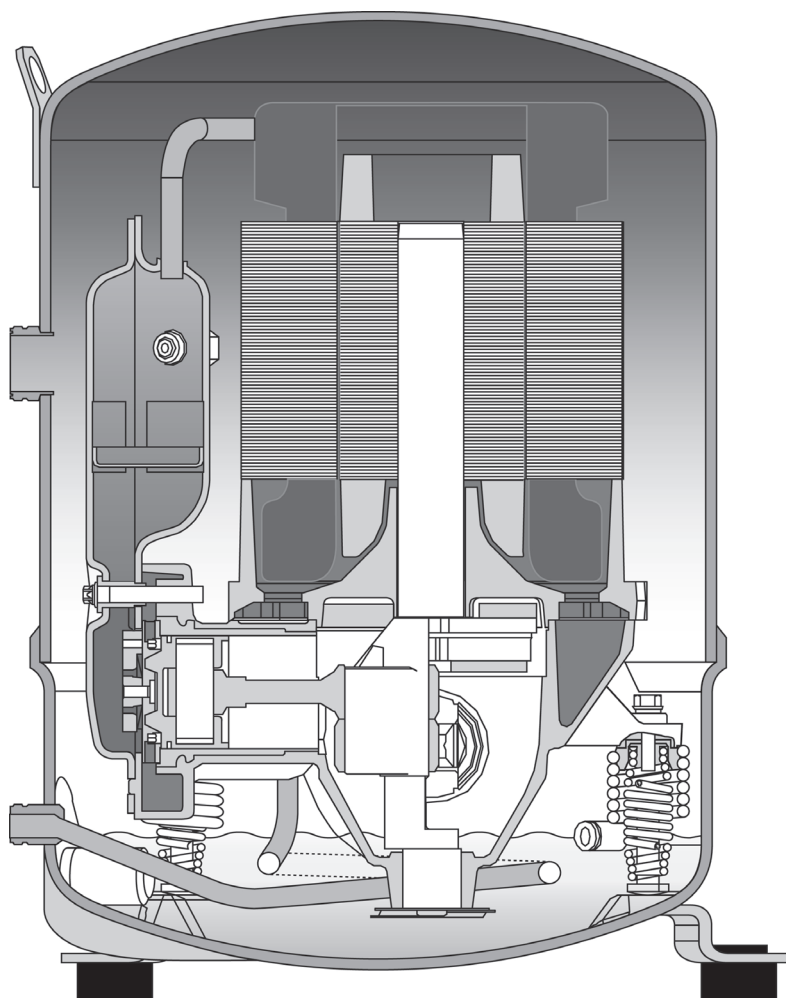

**Code numbers
(for ordering)**

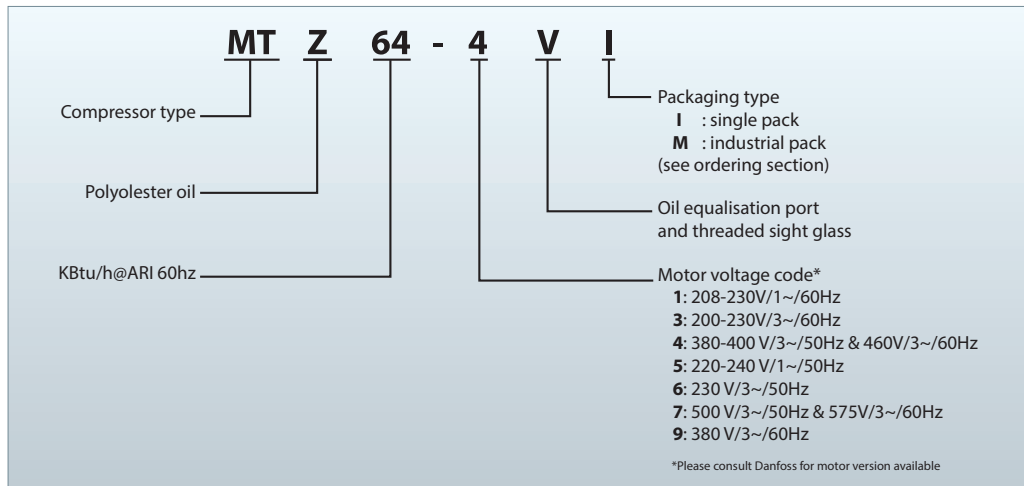

Available code numbers are listed section "Ordering information and packaging"

**Compressor reference
(indicated on the compressor nameplate)**

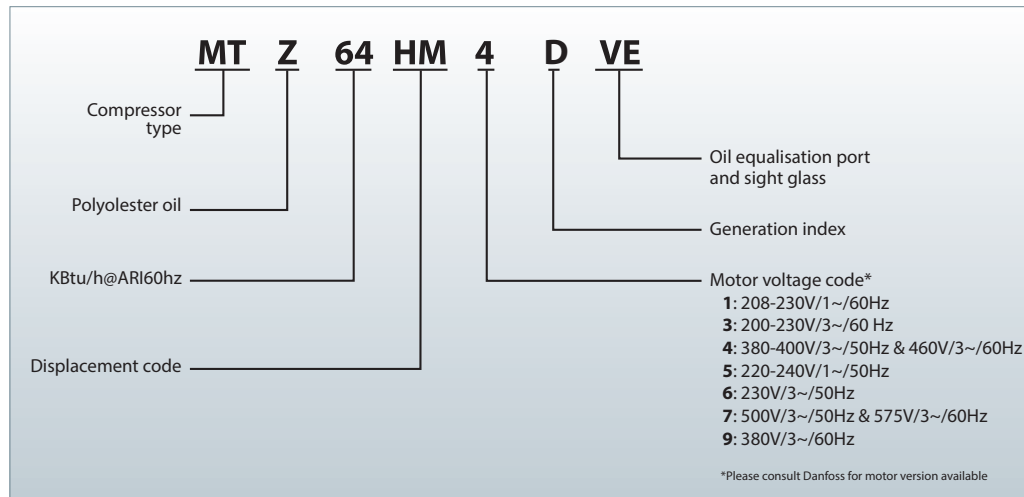

Technical specifications

Compressor model	Displacement			Cyl. number	Oil charge oz	Net weight lbs	Available motor voltage codes						
	Code	in3/rev	cfh at 3600 rpm				1	3	4	5	6	7	9
MT/MTZ018	JA	1.84	231	1	32	46	●	●	●	●	-	-	-
MT/MTZ022	JC	2.33	291	1	32	46	●	●	●	●	●	-	●
MT/MTZ028	JE	2.93	367	1	32	51	●	●	●	●	●	-	○
MT/MTZ032	JF	3.29	411	1	32	53	●	●	●	●	●	○	●
MT/MTZ036	JG	3.69	461	1	32	53	●	●	●	●	●	○	○
MT/MTZ040	JH	4.14	518	1	32	53	●	●	●	-	●	-	-
MT/MTZ044	HJ	4.65	581	2	61	77	○	●	●	-	○	○	●
MT/MTZ050	HK	5.23	653	2	61	77	●	●	●	-	●	○	●
MT/MTZ056	HL	5.87	733	2	61	82	●	●	●	-	●	●	●
MT/MTZ064	HM	6.57	822	2	61	82	●	●	●	-	●	-	●
MT/MTZ072	HN	7.38	922	2	61	88	-	●	●	-	○	-	●
MT/MTZ080	HP	8.29	1036	2	61	88	-	●	●	-	●	-	●
MT/MTZ100	HS	10.45	1306	4	132	132	-	●	●	-	●	●	●
MT/MTZ125	HU	13.15	1643	4	132	141	-	●	●	-	●	●	●
MT/MTZ144	HV	14.76	1845	4	132	148	-	●	●	-	●	●	●
MT/MTZ160	HW	16.57	2071	4	132	148	-	●	●	-	●	●	●

● Available in MT and MTZ

○ Available in MTZ only

Approvals and certificates

Maneurop® MT/MTZ compressors comply with the following approvals and certificates.

Other certificates/approvals please contact Danfoss

CE (European Directive)		All models
UL (Underwriters Laboratories)		All 60 Hz models
CCC (China Compulsory Product Certification)		All models code 4 and 5 under CCC scope.
EAC Eurasian conformity mark		All models voltage code 4 and 5

Pressure equipment directive 2014/68/EU

Products	MT/MTZ 018 to 040	MTZ 018 to 080**	MT/MTZ 044 to 160
Refrigerating fluids*	Group 2	Group 1	Group 2
Category PED	I	II	II
Evaluation module	no scope	D1	D1
Maximum/minimum allowable temperature - TS	122°F > Ts > -31°F	122°F > Ts > -31°F	122°F > Ts > -31°F
MT maximum allowable pressure - PS	267 psig	267 psig	267 psig
MTZ maximum allowable pressure - PS	328 psig	328 psig	328 psig

* According to the PED classification Group1 contains hazardous fluids e.g. flammable, while Group 2 all other fluids
 ** MTZ 018 to 040 - only motor code 1, 3, 4, 5 and MTZ 044 to 080 - only motor code 1, 3, 4

Low voltage directive 2014/35/EU

Products	MT/MTZ 018 to 040	MT/MTZ 044 to 160
Manufacturer's declaration	contact Danfoss	contact Danfoss

Machinery directive 2014/30/EU

Products	MT/MTZ 018 to 040	MT/MTZ 044 to 160
Manufacturer's declaration	contact Danfoss	contact Danfoss

Internal free volume

Products	Volume (gallon)	
	Low side	High side
1 cyl.	1.984	0.106
2 cyl.	4.471	0.202
4 cyl.	8.915	0.397

Nominal performance data for R404A and R22

Compressor model	Refrigeration											
	50 Hz, EN12900 ratings To = 14°F, Tc = 113°F, SC = 0 F, SH = 18°F				50 Hz, ARI ratings To = 20°F, Tc = 120°F, SC = 0°F, SH = 20°F				60 Hz, ARI ratings To = 20°F, Tc = 120°F, SC = 0°F, SH = 20°F			
	Cooling capacity BTU/h	Power input kW	Current input A	C.O.P. Btu.h/W	Cooling capacity BTU/h	Power input kW	Current input A	E.E.R. Btu.h/W	Cooling capacity BTU/h	Power input kW	Current input A	E.E.R. Btu.h/W
MTZ018-4*	6500	1.21	2.73	5.40	7100	1.31	2.86	5.40	9000	1.76	2.86	5.09
MTZ022-4*	9000	1.48	3.06	6.05	9700	1.62	3.24	5.96	12300	2.05	3.27	6.00
MTZ028-4*	11700	1.96	4.04	5.98	12600	2.14	4.30	5.88	16000	2.68	4.23	5.95
MTZ032-4*	13600	2.16	4.25	6.29	14600	2.37	4.56	6.15	17500	2.98	4.56	5.85
MTZ036-4*	15900	2.58	4.95	6.19	17100	2.83	5.33	6.02	20200	3.33	5.09	6.04
MTZ040-4*	18200	2.95	5.87	6.17	19400	3.24	6.29	5.97	23000	3.76	5.88	6.11
MTZ044-4*	18300	2.77	5.35	6.60	19800	3.02	5.67	6.53	24300	3.85	5.85	6.30
MTZ050-4*	21400	3.22	5.95	6.64	22900	3.50	6.33	6.54	28600	4.42	6.53	6.46
MTZ056-4*	22900	3.51	6.83	6.52	24800	3.85	7.25	6.43	32500	4.98	7.52	6.50
MTZ064-4*	27200	4.20	7.82	6.48	29400	4.60	8.35	6.37	36100	5.67	8.31	6.35
MTZ072-4*	30400	4.69	8.95	6.50	32700	5.11	9.50	6.39	40900	6.53	9.73	6.25
MTZ080-4*	35700	5.61	10.20	6.37	38200	6.14	10.94	6.22	46500	7.81	11.35	5.94
MTZ100-4*	41900	6.76	12.21	6.20	45000	7.35	12.94	6.11	52900	8.72	12.79	6.06
MTZ125-4*	53600	8.44	13.79	6.35	57500	9.21	14.86	6.22	68300	11.37	15.41	6.00
MTZ144-4*	63100	9.78	16.29	6.46	67300	10.65	17.47	6.31	80500	12.99	17.93	6.18
MTZ160-4*	69300	11.08	18.26	6.26	74100	12.09	19.64	6.11	87400	14.73	20.17	5.92

* 50 Hz, EN12900 data for indicated models are Asercom certified

R404A data are also valid for refrigerant R507A

Compressor model	Refrigeration				Air conditioning							
	50 Hz, EN12900 ratings To = 14°F, Tc = 113°F, SC = 0 F, SH = 18°F				50 Hz, ARI ratings To = 45°F, Tc = 130°F, SC = 15°F, SH = 20°F				60 Hz, ARI ratings To = 45°F, Tc = 130°F, SC = 15°F, SH = 20°F			
	Cooling capacity BTU/h	Power input kW	Current input A	C.O.P. Btu.h/W	Cooling capacity BTU/h	Power input kW	Current input A	E.E.R. Btu.h/W	Cooling capacity BTU/h	Power input kW	Current input A	E.E.R. Btu.h/W
MT018-4	5770	1.00	2.27	5.77	13240	1.45	2.73	9.16	15900	1.74	2.73	9.16
MT022-4	8500	1.29	2.55	6.59	18290	1.89	3.31	9.69	21980	2.27	3.31	9.69
MT028-4	12730	1.81	3.59	7.03	25190	2.55	4.56	9.87	30200	3.06	4.56	9.87
MT032-4	13480	2.11	3.73	6.39	27510	2.98	4.97	9.22	33040	3.58	4.97	9.22
MT036-4	16420	2.35	4.30	6.99	31640	3.37	5.77	9.38	37990	4.05	5.77	9.38
MT040-4	17820	2.67	4.86	6.67	35770	3.86	6.47	9.27	42900	4.63	6.47	9.27
MT044-4	16590	2.46	5.02	6.74	35900	3.53	6.37	10.17	43990	4.32	6.42	10.18
MT050-4	20030	2.94	5.53	6.81	41740	4.19	7.20	9.97	50140	5.04	7.26	9.95
MT056-4	21980	3.18	6.39	6.91	46930	4.58	8.19	10.24	56380	5.58	8.23	10.10
MT064-4	26450	3.64	7.03	7.27	53690	5.27	9.16	10.18	64330	6.32	9.33	10.18
MT072-4	29730	4.19	8.48	7.10	62120	6.12	10.98	10.15	74540	7.33	10.77	10.16
MT080-4	35360	4.89	9.52	7.23	70780	7.08	12.48	9.99	84910	8.50	12.34	10.00
MT100-4	38670	5.79	11.82	6.68	79860	7.98	14.59	10.00	95840	9.58	14.59	10.00
MT125-4	52080	7.55	12.28	6.90	103860	10.66	17.37	9.74	124610	12.80	17.37	9.74
MT144-4	58980	8.47	17.06	6.96	117200	11.95	22.75	9.80	140650	14.35	22.75	9.80
MT160-4	65490	9.49	16.81	6.90	130610	13.40	22.16	9.75	156760	16.08	22.16	9.75

To: Evaporating temperature at dew point (saturated suction temperature)
Tc: Condensing temperature at dew point (saturated discharge temperature)

SC: Subcooling
SH: Superheat

ARI capacity and power input data are +/- 5%

Asercom: Association of European Refrigeration Compressor and Controls Manufacturers

ARI: Air Conditioning and Refrigeration Institute

Application Guidelines Specifications

Nominal performance data for R407C and R134a

Compressor model	Air conditioning											
	50 Hz, EN12900 ratings To = 41°F, Tc = 122°F, SC = 0°F, SH = 18°F				50 Hz, ARI ratings To = 45°F, Tc = 130°F, SC = 15°F, SH = 20°F				60 Hz, ARI ratings To = 45°F, Tc = 130°F, SC = 15°F, SH = 20°F			
	Cooling capacity BTU/h	Power input kW	Current input A	C.O.P. Btu.h/W	Cooling capacity BTU/h	Power input kW	Current input A	E.E.R. Btu.h/W	Cooling capacity BTU/h	Power input kW	Current input A	E.E.R. Btu.h/W
MTZ018-4*	11840	1.27	2.73	9.32	13140	1.38	2.86	9.53	17240	1.73	2.82	9.98
MTZ022-4*	15530	1.71	3.27	9.08	17130	1.86	3.47	9.23	21430	2.26	3.45	9.48
MTZ028-4*	20070	2.17	4.30	9.25	22320	2.36	4.57	9.45	28050	2.82	4.41	9.93
MTZ032-4*	22700	2.43	4.57	9.34	25020	2.65	4.90	9.43	30680	3.20	4.80	9.61
MTZ036-4*	25630	2.93	5.58	8.75	28260	3.21	5.99	8.82	34100	3.90	5.78	8.74
MTZ040-4*	29560	3.40	6.46	8.69	32700	3.71	6.92	8.81	40000	4.46	6.69	8.98
MTZ044-4*	31160	3.12	5.84	9.99	34470	3.38	6.18	10.21	43450	4.25	6.34	10.23
MTZ050-4*	35560	3.69	6.51	9.64	39350	4.01	6.95	9.82	48160	4.87	7.06	9.89
MTZ056-4*	39860	4.02	7.45	9.92	44370	4.37	7.91	10.16	54780	5.40	8.03	10.15
MTZ064-4*	45600	4.61	8.35	9.89	50680	5.02	8.91	10.10	61710	6.14	9.01	10.05
MTZ072-4*	52290	5.42	9.85	9.65	58190	5.87	10.48	9.91	70920	7.30	10.61	9.72
MTZ080-4*	59320	6.29	11.31	9.43	65970	6.83	12.08	9.67	78050	8.24	11.99	9.47
MTZ100-4*	69900	7.38	13.05	9.47	77470	8.00	13.83	9.69	96310	9.86	14.22	9.77
MTZ125-4*	91740	9.48	15.14	9.68	101640	10.32	16.28	9.85	121570	12.83	18.07	9.47
MTZ144-4*	101600	10.68	17.55	9.51	112830	11.59	18.80	9.74	139590	14.42	19.81	9.68
MTZ160-4*	116350	12.40	20.08	9.38	129040	13.46	21.50	9.59	154330	16.64	22.46	9.27

* 50 Hz, EN12900 data for indicated models are Asercom certified

Compressor model	Refrigeration				Air conditioning							
	50 Hz, EN12900 ratings To = 14°F, Tc = 113°F, SC = 0°F, SH = 18°F				50 Hz, ARI ratings To = 45°F, Tc = 130°F, SC = 15°F, SH = 20°F				60 Hz, ARI ratings To = 45°F, Tc = 130°F, SC = 15°F, SH = 20°F			
	Cooling capacity BTU/h	Power input kW	Current input A	C.O.P. Btu.h/W	Cooling capacity BTU/h	Power input kW	Current input A	E.E.R. Btu.h/W	Cooling capacity BTU/h	Power input kW	Current input A	E.E.R. Btu.h/W
MTZ018-4	3670	0.69	1.92	5.33	8640	0.99	2.02	8.73	10370	1.19	2.11	8.73
MTZ022-4	4800	0.82	2.16	5.89	11380	1.20	2.51	9.51	13660	1.44	2.62	9.51
MTZ028-4	6220	1.02	2.83	6.10	14400	1.53	3.30	9.40	17280	1.84	3.44	9.40
MTZ032-4	7090	1.25	3.33	5.68	16750	1.87	3.94	8.95	20110	2.25	4.11	8.95
MTZ036-4	9390	1.45	3.32	6.48	20530	2.13	4.09	9.62	24640	2.56	4.27	9.62
MTZ040-4	9940	1.61	3.81	6.18	21650	2.33	4.89	9.28	25980	2.80	5.10	9.28
MTZ044-4	9980	1.49	4.05	6.68	23340	2.22	4.73	10.51	28010	2.66	4.93	10.51
MTZ050-4	11480	1.80	4.32	6.37	27160	2.63	5.20	10.32	32600	3.16	5.42	10.32
MTZ056-4	12030	1.88	5.31	6.39	29440	2.85	6.17	10.34	35330	3.41	6.44	10.34
MTZ064-4	14300	2.17	5.71	6.60	34340	3.26	6.81	10.52	41210	3.92	7.10	10.52
MTZ072-4	16630	2.50	6.67	6.64	39420	3.78	7.99	10.42	47300	4.54	8.33	10.42
MTZ080-4	19980	2.93	7.22	6.82	45280	4.35	8.83	10.40	54340	5.22	9.21	10.40
MTZ100-4	22580	3.65	8.67	6.19	52760	5.28	10.24	9.99	63310	6.33	10.68	9.99
MTZ125-4	28340	4.17	8.35	6.79	64670	6.29	10.80	10.28	77600	7.55	11.26	10.28
MTZ144-4	36620	5.40	11.02	6.78	80360	7.83	13.78	10.26	96430	9.39	14.37	10.26
MTZ160-4	40610	5.84	11.37	6.96	88010	8.57	14.67	10.26	105600	10.29	15.30	10.26

To: Evaporating temperature at dew point (saturated suction temperature)
Tc: Condensing temperature at dew point (saturated discharge temperature)

SC: Subcooling
SH: Superheat

ARI capacity and power input data are +/- 5%

Asercom: Association of European Refrigeration Compressor and Controls Manufacturers

ARI: Air Conditioning and Refrigeration Institute

Nominal performance data for R407A and R407F

Compressor model	Refrigeration											
	50 Hz, EN12900 ratings To = 14°F, Tc = 113°F, SC = 0°F, SH = 18°F				50 Hz, ARI ratings To = 20°F, Tc = 120°F, SC = 0°F, SH = 20°F				60 Hz, ARI ratings To = 20°F, Tc = 120°F, SC = 0°F, SH = 20°F			
	Cooling capacity BTU/h	Power input kW	Current input A	C.O.P. Btu.h/W	Cooling capacity BTU/h	Power input kW	Current input A	E.E.R. Btu.h/W	Cooling capacity BTU/h	Power input kW	Current input A	E.E.R. Btu.h/W
MTZ018-4	5900	1.02	2.46	5.81	6600	1.12	2.58	5.91	8000	1.35	2.69	5.89
MTZ022-4	8200	1.26	2.75	6.49	9100	1.39	2.91	6.51	10900	1.67	3.04	6.50
MTZ028-4	10700	1.67	3.63	6.41	11900	1.85	3.87	6.40	14200	2.22	4.04	6.40
MTZ032-4	12400	1.84	3.82	6.74	13700	2.04	4.10	6.69	16400	2.45	4.28	6.69
MTZ036-4	14500	2.19	4.45	6.64	16000	2.43	4.80	6.56	19200	2.92	5.00	6.55
MTZ040-4	16700	2.51	5.28	6.63	18300	2.80	5.67	6.51	21900	3.36	5.91	6.51
MTZ044-4	16700	2.36	4.81	7.08	18500	2.60	5.11	7.10	22200	3.12	5.33	7.10
MTZ050-4	19500	2.73	5.35	7.13	21500	3.01	5.69	7.12	25800	3.61	5.94	7.12
MTZ056-4	20900	2.98	6.14	7.00	23200	3.30	6.53	7.02	27800	3.96	6.81	7.02
MTZ064-4	24800	3.57	7.04	6.95	27500	3.95	7.51	6.95	33000	4.75	7.83	6.93
MTZ072-4	27800	3.98	8.05	6.98	30700	4.40	8.55	6.95	36800	5.27	8.92	6.97
MTZ080-4	32600	4.76	9.17	6.84	35800	5.28	9.85	6.77	43000	6.33	10.27	6.78
MTZ100-4	38200	5.74	10.98	6.66	42100	6.32	11.65	6.65	50600	7.58	12.15	6.66
MTZ125-4	48900	7.17	12.40	6.82	53800	7.93	13.38	6.77	64600	9.51	13.95	6.78
MTZ144-4	57600	8.32	14.65	6.92	63100	9.18	15.72	6.86	75700	11.02	16.40	6.86
MTZ160-4	63200	9.42	16.42	6.71	69400	10.43	17.68	6.64	83300	12.51	18.44	6.65

To: Evaporating temperature at dew point (saturated suction temperature)
Tc: Condensing temperature at dew point (saturated discharge temperature)

SC: Subcooling
SH: Superheat

Compressor model	Refrigeration											
	50 Hz, EN12900 ratings To = 14°F, Tc = 113°F, SC = 0°F, SH = 18°F				50 Hz, ARI ratings To = 20°F, Tc = 120°F, SC = 0°F, SH = 20°F				60 Hz, ARI ratings To = 20°F, Tc = 120°F, SC = 0°F, SH = 20°F			
	Cooling capacity BTU/h	Power input kW	Current input A	C.O.P. Btu.h/W	Cooling capacity BTU/h	Power input kW	Current input A	E.E.R. Btu.h/W	Cooling capacity BTU/h	Power input kW	Current input A	E.E.R. Btu.h/W
MTZ018-4	6300	1.08	2.53	5.82	7100	1.19	2.66	5.97	8500	1.43	2.77	5.97
MTZ022-4	8700	1.33	2.83	6.52	9700	1.48	3.01	6.55	11600	1.77	3.14	6.58
MTZ028-4	11300	1.76	3.74	6.45	12700	1.96	4.00	6.44	15200	2.35	4.17	6.46
MTZ032-4	13200	1.94	3.93	6.78	14600	2.16	4.24	6.76	17600	2.59	4.42	6.76
MTZ036-4	15400	2.31	4.58	6.67	17100	2.58	4.95	6.63	20500	3.10	5.17	6.62
MTZ040-4	17600	2.65	5.43	6.66	19500	2.96	5.85	6.57	23400	3.55	6.10	6.58
MTZ044-4	17700	2.49	4.95	7.12	19900	2.76	5.28	7.18	23800	3.31	5.50	7.19
MTZ050-4	20700	2.90	5.50	7.14	23000	3.20	5.88	7.18	27600	3.84	6.13	7.18
MTZ056-4	22200	3.16	6.31	7.03	24900	3.51	6.74	7.07	29800	4.21	7.03	7.08
MTZ064-4	26400	3.78	7.23	6.99	29500	4.19	7.76	7.02	35400	5.03	8.09	7.02
MTZ072-4	29500	4.21	8.27	7.00	32900	4.66	8.84	7.04	39400	5.60	9.22	7.03
MTZ080-4	34600	5.04	9.43	6.87	38400	5.60	10.18	6.84	46100	6.71	10.61	6.85
MTZ100-4	40600	6.07	11.28	6.69	45200	6.71	12.04	6.72	54300	8.05	12.55	6.73
MTZ125-4	51900	7.58	12.75	6.85	57700	8.41	13.82	6.85	69200	10.09	14.41	6.85
MTZ144-4	61100	8.78	15.06	6.96	67600	9.72	16.24	6.94	81100	11.66	16.94	6.94
MTZ160-4	67100	9.95	16.88	6.75	74300	11.03	18.26	6.73	89200	13.24	19.05	6.73

To: Evaporating temperature at dew point (saturated suction temperature)
Tc: Condensing temperature at dew point (saturated discharge temperature)

SC: Subcooling
SH: Superheat

Asercom: Association of European Refrigeration Compressor and Controls Manufacturers
ARI: Air Conditioning and Refrigeration Institute

Nominal performance data R448A/R449A and R452A

Compressor model	Refrigeration											
	50 Hz, EN12900 ratings To = 14 °F, Tc = 113°F, SC = 0°F, SH = 18°F				50 Hz, ARI ratings To = 20 °F, Tc = 120 °F, SC = 0°F, SH = 20°F				60 Hz, ARI ratings To = 20 °F, Tc = 120 °F, SC = 0°F, SH = 20°F			
	Cooling capacity BTU/h	Power input kW	Current input A	E.E.R. Btu.h/W	Cooling capacity BTU/h	Power input kW	Current input A	E.E.R. Btu.h/W	Cooling capacity BTU/h	Power input kW	Current input A	E.E.R. Btu.h/W
MTZ018-4	6276	1.04	2.55	6.06	6911	1.14	2.66	6.08	8294	1.36	2.78	6.08
MTZ022-4	8795	1.37	2.86	6.42	9611	1.52	3.03	6.34	11536	1.82	3.16	6.35
MTZ028-4	10860	1.69	3.85	6.44	11867	1.87	4.07	6.36	14242	2.24	4.25	6.36
MTZ032-4	12495	1.87	3.68	6.68	13560	2.08	3.97	6.53	16273	2.49	4.14	6.54
MTZ036-4	14498	2.24	4.65	6.48	15881	2.48	4.97	6.39	19058	2.98	5.18	6.40
MTZ040-4	16648	2.62	5.87	6.36	18232	2.90	6.27	6.28	21877	3.48	6.54	6.28
MTZ044-4	17096	2.49	4.94	6.87	18761	2.74	5.25	6.86	22515	3.28	5.48	6.86
MTZ050-4	19464	2.87	5.41	6.77	21519	3.18	5.74	6.76	25823	3.82	5.99	6.76
MTZ056-4	21638	3.16	6.53	6.84	23922	3.50	6.93	6.83	28703	4.20	7.23	6.83
MTZ064-4	25017	3.62	7.05	6.91	27444	4.01	7.56	6.85	32935	4.81	7.89	6.85
MTZ072-4	28795	4.20	8.80	6.86	31594	4.64	9.44	6.80	37911	5.57	9.85	6.80
MTZ080-4	34157	4.97	9.66	6.88	37314	5.48	10.34	6.81	44775	6.57	10.79	6.82
MTZ100-4	38601	5.79	10.99	6.67	42406	6.37	11.66	6.66	50881	7.65	12.17	6.65
MTZ125-4	51939	7.45	13.24	6.98	57065	8.19	14.06	6.97	68468	9.88	14.67	6.93
MTZ144-4	59942	8.63	15.45	6.94	64980	9.50	16.69	6.84	77969	11.40	17.40	6.84
MTZ160-4	68747	9.87	17.11	6.96	74515	10.87	18.48	6.86	89416	13.04	19.27	6.86

To: Evaporating temperature at dew point (saturated suction temperature)
Tc: Condensing temperature at dew point (saturated discharge temperature)
SC: Subcooling
SH: Superheat

Compressor model	Refrigeration											
	50 Hz, EN12900 ratings To = 14 °F, Tc = 113°F, SC = 0°F, SH = 18°F				50 Hz, ARI ratings To = 20 °F, Tc = 120 °F, SC = 0°F, SH = 20°F				60 Hz, ARI ratings To = 20 °F, Tc = 120 °F, SC = 0°F, SH = 20°F			
	Cooling capacity BTU/h	Power input kW	Current input A	E.E.R. Btu.h/W	Cooling capacity BTU/h	Power input kW	Current input A	E.E.R. Btu.h/W	Cooling capacity BTU/h	Power input kW	Current input A	E.E.R. Btu.h/W
MTZ018-4	6809	1.15	2.65	5.94	7348	1.25	2.77	5.90	8819	1.49	2.88	5.90
MTZ022-4	9573	1.51	2.98	6.34	10276	1.65	3.15	6.21	12331	1.98	3.29	6.22
MTZ028-4	11092	1.86	4.00	5.97	11867	2.03	4.23	5.84	14239	2.44	4.41	5.84
MTZ032-4	12925	2.06	3.83	6.27	13840	2.27	4.13	6.09	16608	2.73	4.31	6.09
MTZ036-4	14669	2.48	4.84	5.92	15737	2.72	5.17	5.79	18884	3.26	5.39	5.79
MTZ040-4	17369	2.89	6.11	6.00	18662	3.18	6.52	5.87	22392	3.81	6.80	5.87
MTZ044-4	18314	2.73	5.24	6.70	19741	2.98	5.55	6.62	23689	3.58	5.79	6.62
MTZ050-4	20846	3.16	5.74	6.60	22635	3.47	6.07	6.52	27164	4.16	6.33	6.53
MTZ056-4	23181	3.48	6.93	6.67	25167	3.82	7.33	6.59	30198	4.58	7.64	6.59
MTZ064-4	26754	3.98	7.48	6.73	28833	4.36	8.00	6.61	34601	5.24	8.34	6.61
MTZ072-4	30799	4.61	9.34	6.68	33195	5.06	9.98	6.57	39833	6.07	10.41	6.57
MTZ080-4	33041	5.26	10.04	6.29	35454	5.75	10.72	6.17	42546	6.90	11.18	6.17
MTZ100-4	42010	6.37	11.68	6.59	45294	6.97	12.42	6.50	54352	8.37	12.96	6.50
MTZ125-4	54843	8.19	13.23	6.69	59130	8.96	14.06	6.60	70956	10.75	14.67	6.60
MTZ144-4	60846	9.58	15.96	6.35	64686	10.46	17.26	6.18	77625	12.55	18.00	6.18
MTZ160-4	67853	10.80	17.68	6.28	72113	11.80	19.11	6.11	86536	14.16	19.93	6.11

To: Evaporating temperature at dew point (saturated suction temperature)
Tc: Condensing temperature at dew point (saturated discharge temperature)
SC: Subcooling
SH: Superheat

Nominal performance data R454A, R454C, R455A, R455A and R513A

Compressor model	Refrigeration											
	50 Hz, EN12900 ratings				50 Hz, AHRI ratings*				60 Hz, AHRI ratings*			
	To = 14°F, Tc = 113°F, SC = 0°F, SH = 18°F				To = 20°F, Tc = 110°F, SC = 0°F, SH = 20°F				To = 20°F, Tc = 110°F, SC = 0°F, SH = 20°F			
	Cooling capacity BTU/h	Power input kW	Current input A	E.E.R. Btu.h/W	Cooling capacity BTU/h	Power input kW	Current input A	E.E.R. Btu.h/W	Cooling capacity BTU/h	Power input kW	Current input A	E.E.R. Btu.h/W
MTZ018-4	6481	1.06	2.81	6.10	8286	1.12	2.85	7.37	10248	1.33	2.29	7.74
MTZ022-4	8669	1.41	2.92	6.14	10729	1.48	2.98	7.26	13684	1.9	3.08	7.22
MTZ028-4	11380	1.84	4.60	6.18	14001	1.92	4.71	7.28	18458	2.45	4.48	7.52
MTZ032-4	13603	2.03	4.12	6.71	16633	2.12	4.22	7.86	21509	2.67	4.27	8.07
MTZ036-4	15048	2.41	5.44	6.26	18421	2.54	5.61	7.26	24208	3.23	5.46	7.5
MTZ040-4	18221	2.85	6.49	6.40	22290	2.94	6.61	7.58	27109	3.58	6.4	7.58
MTZ044-4	18909	2.66	5.10	7.10	23266	2.78	5.23	8.36	28805	3.56	5.4	8.09
MTZ050-4	22137	3.1	5.70	7.14	27290	3.24	5.84	8.42	33511	4.06	5.99	8.26
MTZ056-4	23833	3.39	6.50	7.03	29412	3.56	6.71	8.26	38254	4.62	6.94	8.28
MTZ064-4	28136	4.05	7.40	6.97	34637	4.27	7.72	8.12	42417	5.24	7.68	8.1
MTZ072-4	31688	4.51	8.50	7.03	38834	4.75	8.82	8.18	48219	6.03	8.98	8
MTZ080-4	37265	5.42	9.70	6.86	45079	5.69	10.07	7.93	54498	7.2	10.47	7.58

To: Evaporating temperature at dew point (saturated suction temperature)
Tc: Condensing temperature at dew point (saturated discharge temperature)
SC: Subcooling
SH: Superheat
*: Performance given according to AHRI Standard 540 2020
AHRI: Air Conditioning Heating and Refrigeration Institute

Compressor model	Refrigeration											
	50 Hz, EN12900 ratings				50 Hz, AHRI ratings*				60 Hz, AHRI ratings*			
	To = 14°F, Tc = 113°F, SC = 0°F, SH = 18°F				To = 20°F, Tc = 110°F, SC = 0°F, SH = 20°F				To = 20°F, Tc = 110°F, SC = 0°F, SH = 20°F			
	Cooling capacity BTU/h	Power input kW	Current input A	E.E.R. Btu.h/W	Cooling capacity BTU/h	Power input kW	Current input A	E.E.R. Btu.h/W	Cooling capacity BTU/h	Power input kW	Current input A	E.E.R. Btu.h/W
MTZ018-4	5354	0.87	2.28	6.15	6914	0.93	2.33	7.47	8487	1.15	2.23	7.39
MTZ022-4	7194	1.16	2.39	6.22	8968	1.22	2.44	7.38	11432	1.56	2.53	7.32
MTZ028-4	9446	1.49	3.75	6.32	11678	1.57	3.86	7.45	15397	2	3.67	7.72
MTZ032-4	11319	1.67	3.37	6.80	13926	1.74	3.46	7.99	18049	2.19	3.5	8.25
MTZ036-4	12701	1.97	4.43	6.45	15708	2.09	4.59	7.53	20325	2.63	4.48	7.73
MTZ040-4	15285	2.33	5.30	6.56	18991	2.44	5.42	7.78	22789	2.95	5.24	7.74
MTZ044-4	15715	2.18	4.10	7.21	19475	2.29	4.28	8.51	24058	2.92	4.42	8.25
MTZ050-4	18390	2.54	4.60	7.24	22823	2.66	4.79	8.57	28061	3.32	4.91	8.44
MTZ056-4	19820	2.78	5.30	7.14	24621	2.93	5.5	8.41	32006	3.78	5.68	8.47
MTZ064-4	23393	3.29	6.00	7.10	29034	3.49	6.32	8.32	35490	4.3	6.29	8.26
MTZ072-4	26358	3.7	6.90	7.14	32518	3.9	7.23	8.34	40336	4.94	7.35	8.16
MTZ080-4	31023	4.43	7.90	7.00	37776	4.66	8.26	8.1	45659	5.91	8.58	7.73

To: Evaporating temperature at dew point (saturated suction temperature)
Tc: Condensing temperature at dew point (saturated discharge temperature)
SC: Subcooling
SH: Superheat
*: Performance given according to AHRI Standard 540 2020
AHRI: Air Conditioning Heating and Refrigeration Institute

Application Guidelines Specifications

Compressor model	R455A Refrigeration											
	50 Hz, EN12900 ratings				50 Hz, AHRI ratings*				60 Hz, AHRI ratings*			
	To = 14°F, Tc = 113°F, SC = 0°F, SH = 18°F				To = 20°F, Tc = 110°F, SC = 0°F, SH = 20°F				To = 20°F, Tc = 110°F, SC = 0°F, SH = 20°F			
	Cooling capacity BTU/h	Power input kW	Current input A	E.E.R. Btu.h/W	Cooling capacity BTU/h	Power input kW	Current input A	E.E.R. Btu.h/W	Cooling capacity BTU/h	Power input kW	Current input A	E.E.R. Btu.h/W
MTZ018-4	5829	1	2.50	5.84	7456	1.06	2.53	7.04	9077	1.28	2.4	7.08
MTZ022-4	8272	1.27	2.53	6.52	10251	1.33	2.58	7.7	13196	1.66	2.64	7.94
MTZ028-4	10630	1.6	3.77	6.66	13097	1.67	3.86	7.83	16854	2.11	3.7	8.01
MTZ032-4	12060	1.76	3.52	6.86	14790	1.84	3.61	8.06	19103	2.33	3.68	8.2
MTZ036-4	13657	2.08	4.57	6.59	16749	2.18	4.7	7.67	21301	2.71	4.58	7.86
MTZ040-4	15930	2.43	5.54	6.56	19502	2.51	5.61	7.77	24488	3.12	5.68	7.84
MTZ044-4	17069	2.36	4.40	7.24	21113	2.47	4.6	8.55	26072	3.13	4.75	8.32
MTZ050-4	19967	2.73	5.00	7.31	24741	2.86	5.14	8.65	30381	3.56	5.27	8.52
MTZ056-4	21519	2.98	5.70	7.24	26689	3.14	5.91	8.5	34603	4.04	6.1	8.56
MTZ064-4	25396	3.55	6.50	7.17	31467	3.76	6.79	8.36	38493	4.62	6.75	8.33
MTZ072-4	28610	3.97	7.40	7.21	35251	4.18	7.76	8.42	43748	5.31	7.9	8.24
MTZ080-4	33698	4.77	8.50	7.07	40950	5.01	8.87	8.18	49515	6.34	9.21	7.81

To: Evaporating temperature at dew point (saturated suction temperature)
Tc: Condensing temperature at dew point (saturated discharge temperature)
SC: Subcooling
SH: Superheat

*: Performance given according to AHRI Standard 540 2020
AHRI: Air Conditioning Heating and Refrigeration Institute

Compressor model	R513A Refrigeration											
	50 Hz, EN12900 ratings				50 Hz, AHRI ratings*				60 Hz, AHRI ratings*			
	To = 14°F, Tc = 113°F, SC = 0°F, SH = 18°F				To = 20°F, Tc = 110°F, SC = 0°F, SH = 20°F				To = 20°F, Tc = 110°F, SC = 0°F, SH = 20°F			
	Cooling capacity BTU/h	Power input kW	Current input A	E.E.R. Btu.h/W	Cooling capacity BTU/h	Power input kW	Current input A	E.E.R. Btu.h/W	Cooling capacity BTU/h	Power input kW	Current input A	E.E.R. Btu.h/W
MTZ018-4	4030	0.74	2.37	5.47	5117	0.78	2.40	6.55	6398	0.93	2.15	6.89
MTZ022-4	5275	0.88	2.13	6.01	6671	0.93	2.17	7.18	8494	1.19	2.18	7.17
MTZ028-4	6652	1.14	3.32	5.82	8339	1.2	3.36	6.96	10890	1.48	3.11	7.34
MTZ032-4	7909	1.27	2.90	6.23	9905	1.34	2.98	7.37	12820	1.69	2.93	7.58
MTZ036-4	9112	1.47	3.70	6.18	11360	1.54	3.78	7.4	13510	1.88	3.72	7.2
MTZ040-4	10810	1.78	4.74	6.06	13430	1.86	4.83	7.22	15980	2.19	4.43	7.3
MTZ044-4	10860	1.68	4.13	6.46	13860	1.78	4.21	7.81	16760	2.17	4.05	7.74
MTZ050-4	12350	1.9	4.30	6.50	15430	1.99	4.40	7.74	18580	2.5	4.70	7.44
MTZ056-4	13040	2.05	5.27	6.38	16570	2.16	5.39	7.66	21420	2.78	5.13	7.7
MTZ064-4	15080	2.34	5.70	6.45	19060	2.48	5.83	7.69	23990	3.17	5.64	7.57
MTZ072-4	17190	2.7	7.05	6.38	21550	2.85	7.20	7.56	27300	3.62	6.76	7.54
MTZ080-4	19450	3.09	7.27	6.30	24490	3.26	7.45	7.51	31610	4.2	7.33	7.52

To: Evaporating temperature at dew point (saturated suction temperature)
Tc: Condensing temperature at dew point (saturated discharge temperature)
SC: Subcooling
SH: Superheat

*: Performance given according to AHRI Standard 540 2020
AHRI: Air Conditioning Heating and Refrigeration Institute

R The operating envelopes for MT and MTZ compressors are given in the figures below and guarantees reliable operations of the compressor for steady-state operation.

MT - R22 - R417A

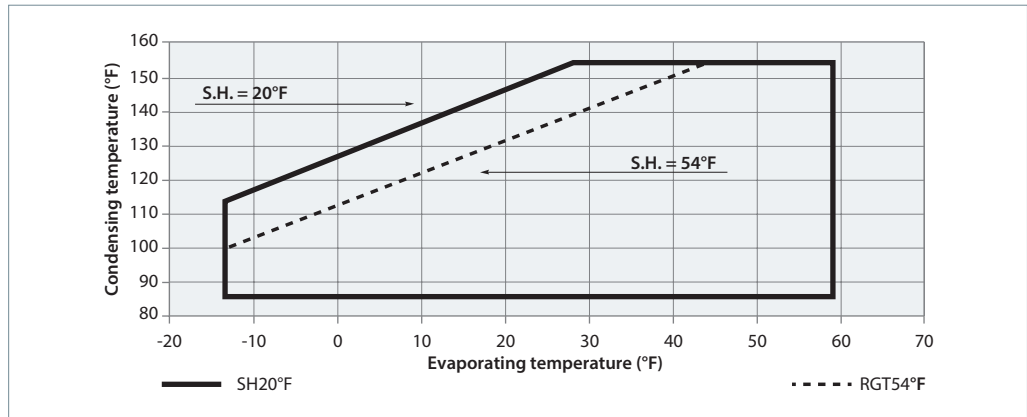

MTZ - R407C at DEW point

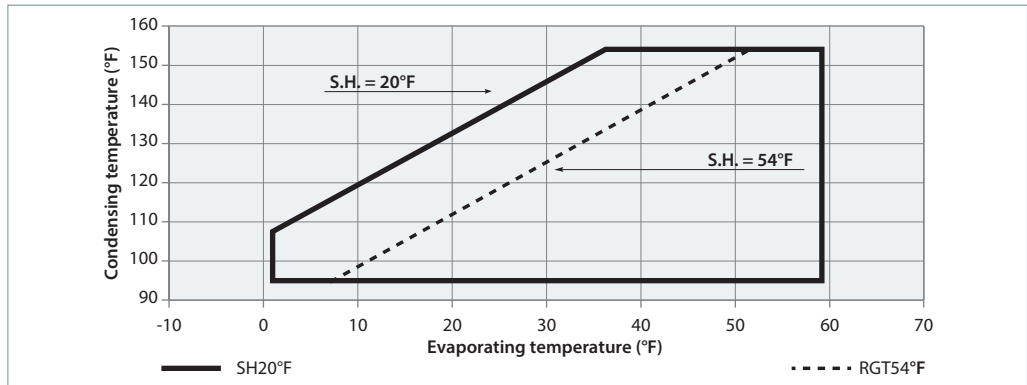

MTZ - R134a

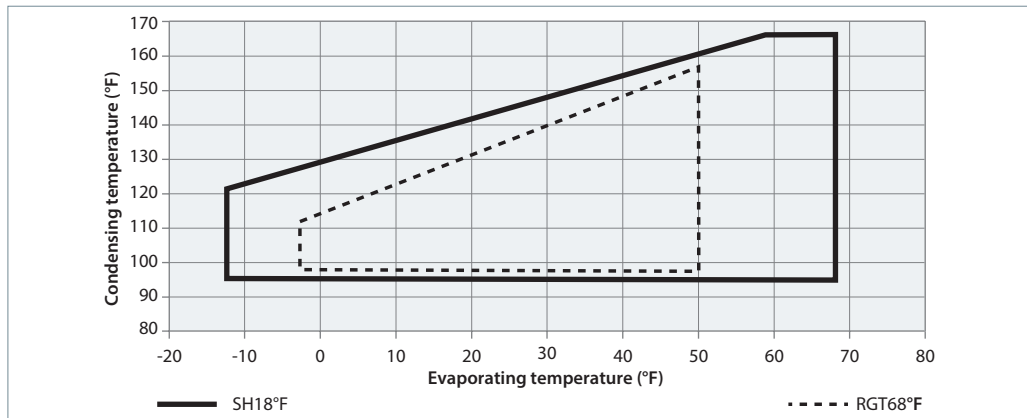

MTZ - R404A / R507A

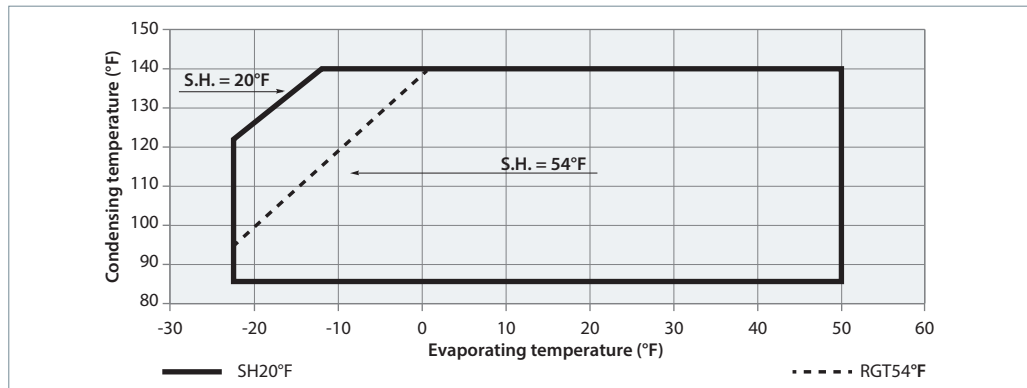

MTZ – R407A at Dew Point

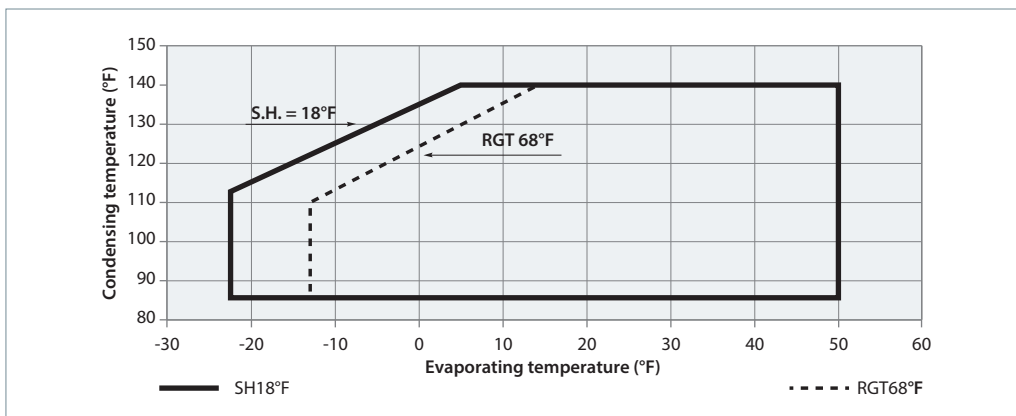

MTZ – R407F at Dew Point

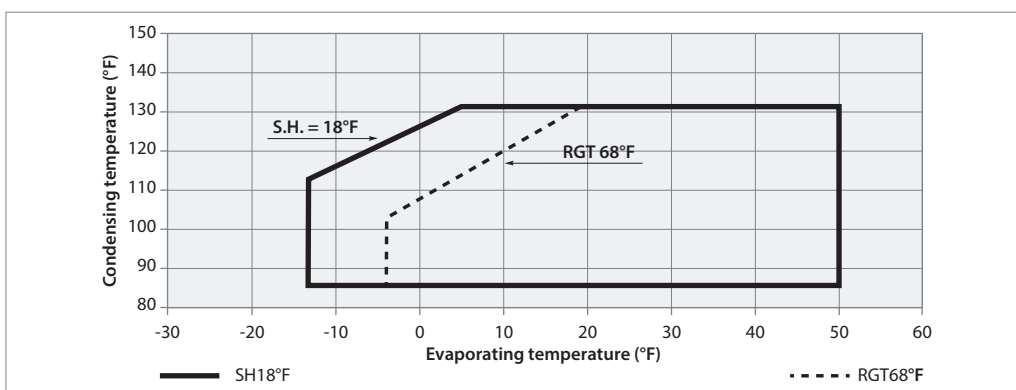

MTZ – R448A/R449A

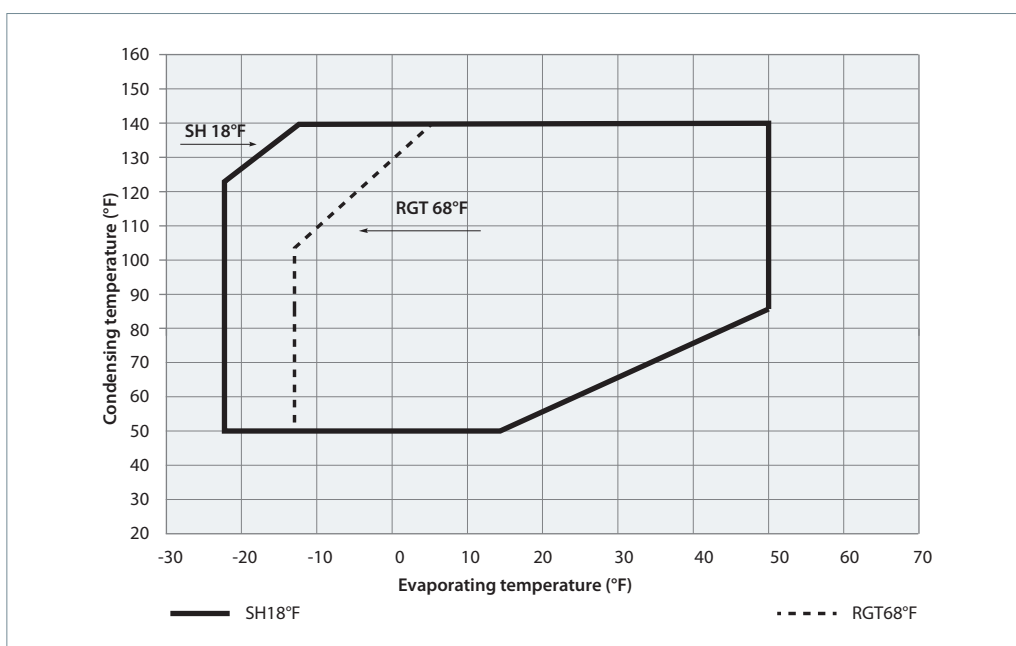

MTZ – R452A

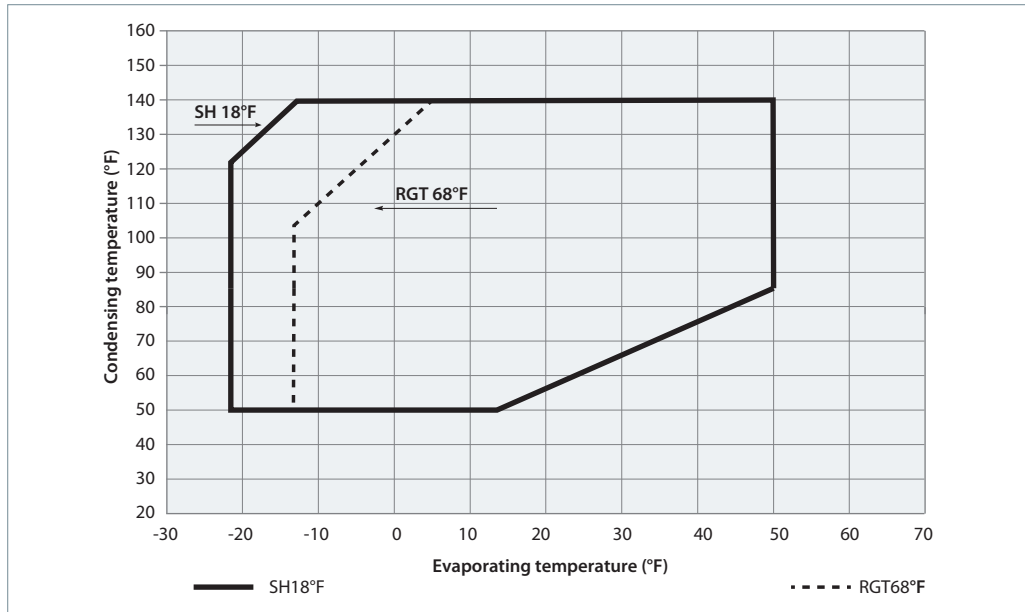

MTZ - R454A - SH18°F

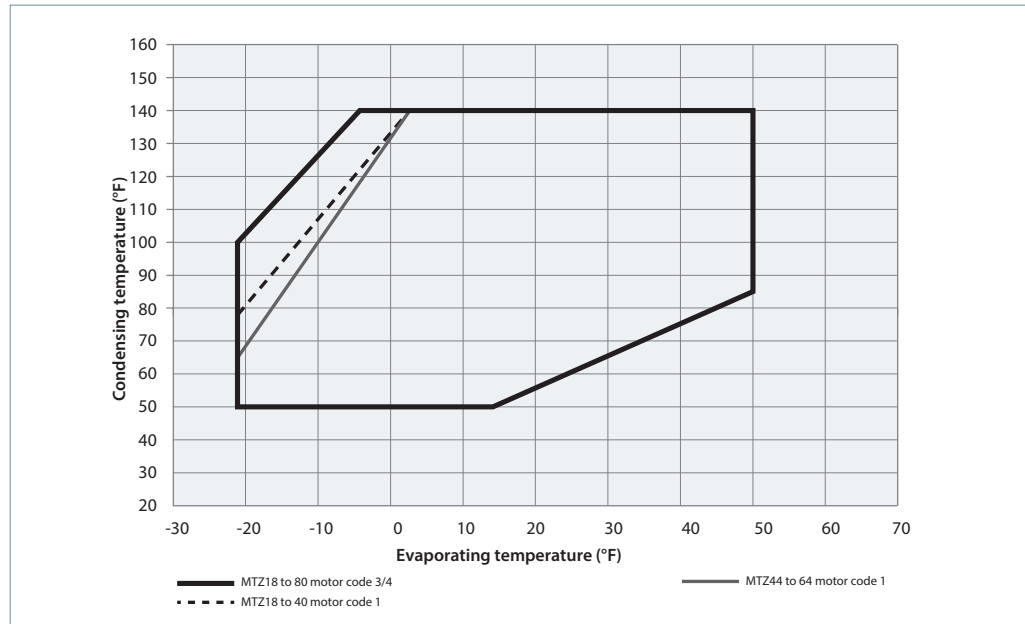

MTZ - R454A - RGT68°F

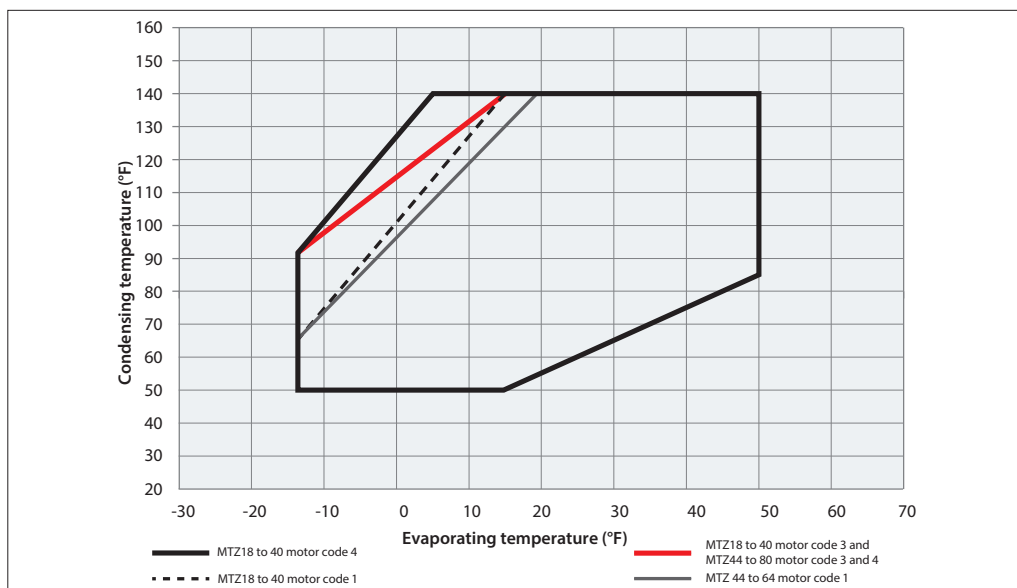

MTZ - R454C / R455A - SH18°F

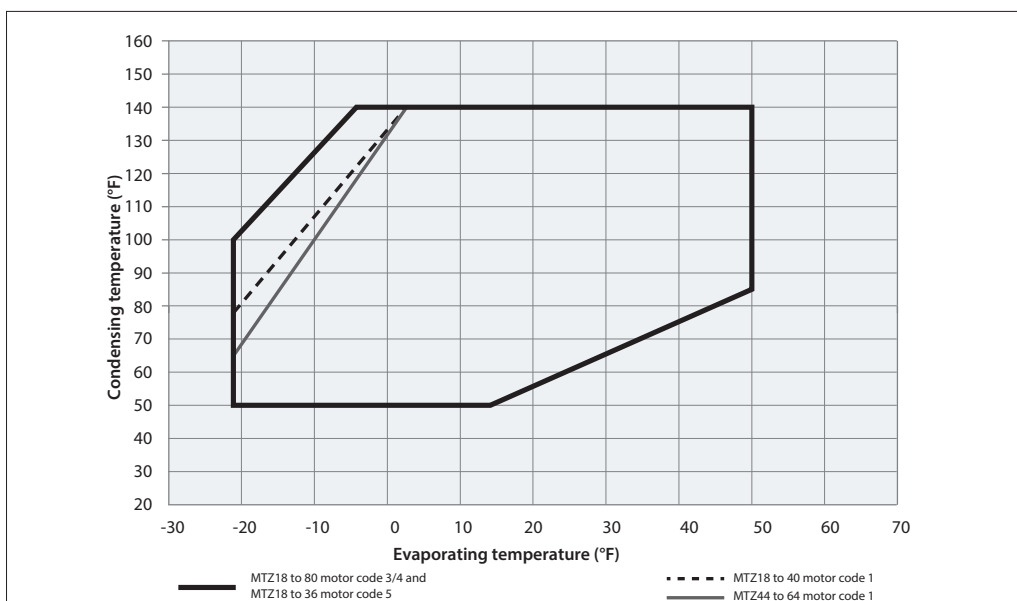

MTZ - R454C / R455A - RGT68°F

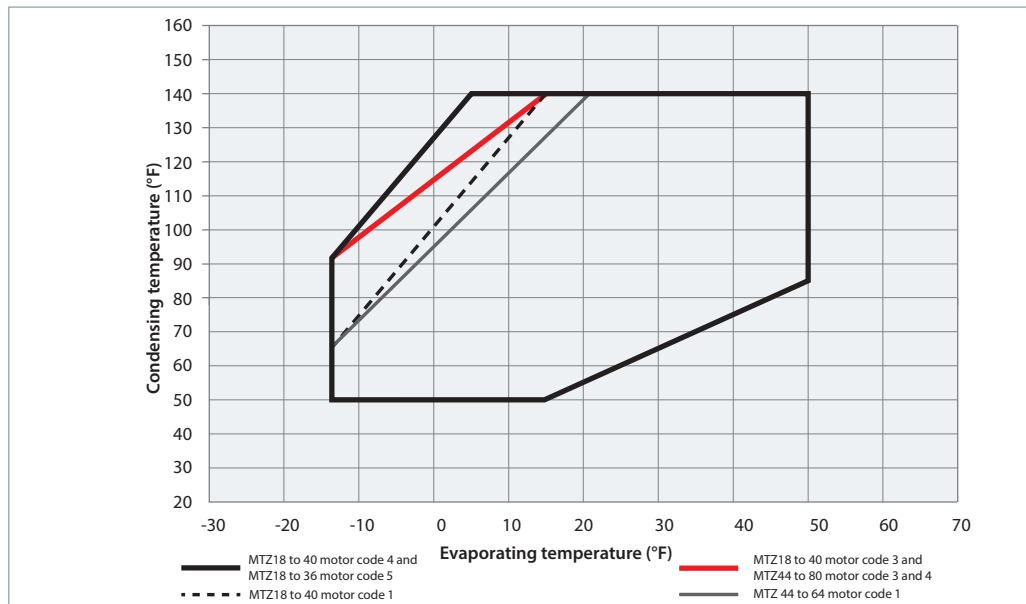

MTZ - R513A

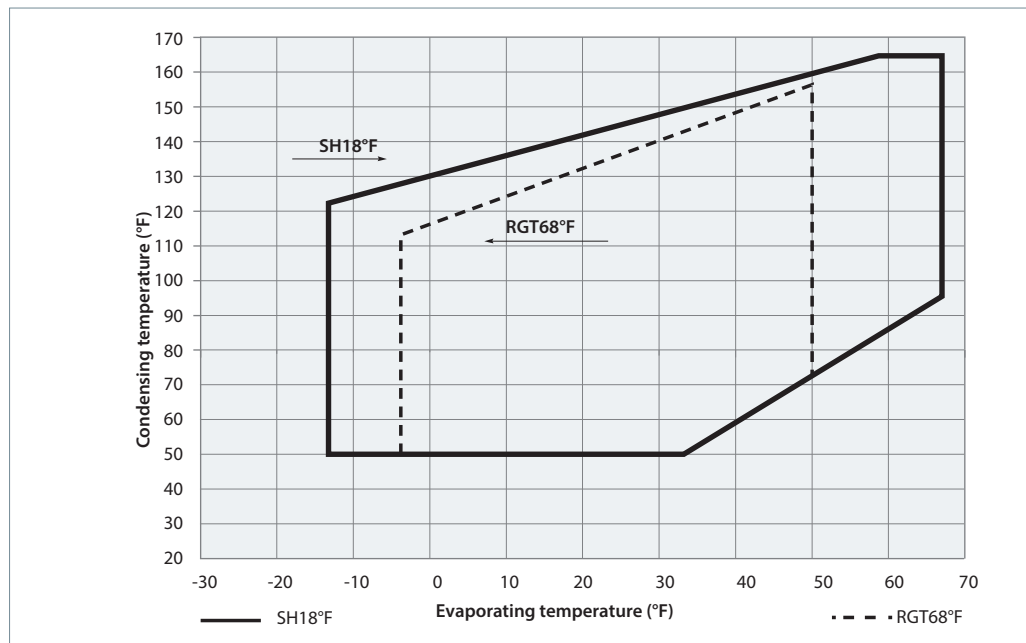

Discharge temperature protection

R Even when the motor windings are protected against overheating by the internal motor protection, the compressor discharge gas temperature could exceed the maximum allowed value of 275°F when the compressor is operated outside its application envelope. The most effective protection against too high discharge gas temperature is to mount a discharge gas thermostat. An accessory kit is available from Danfoss which includes the thermostat, mounting bracket and insulation.

The thermostat must be attached to the discharge line as indicated below at no more than 150 mm from the discharge connection.

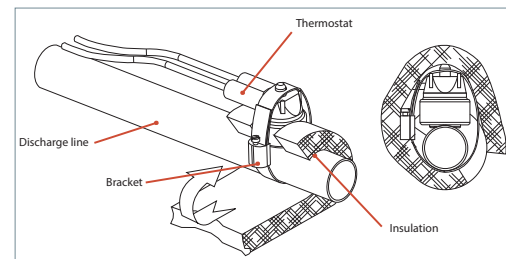

Application Guidelines

Operating envelopes

Zeotropic refrigerant mixtures

Refrigerant mixtures can be either zeotropic or azeotropic.

An azeotropic mixture (like R502 or R507A) behaves like a pure refrigerant. During a phase transition (from vapour to liquid or from liquid to vapour) the composition of vapour and liquid stays the same.

In a zeotropic mixture (like R407C) on the other hand the composition of vapour and liquid changes during the phase transition. When the effect of this phase transition is very small, the mixture is often called a near-azeotropic mixture. R404A is such a near-azeotropic mixture.

The composition change causes phase shift and temperature glide.

Phase shift

In system components where both vapour and liquid phase are present (evaporator, condenser, liquid receiver), the liquid phase and vapour phase do not have the same composition. In fact both phases form two different refrigerants. Therefore zeotropic refrigerants need some

special attention. Zeotropic refrigerants must always be charged in liquid phase. Flooded evaporators should not be applied in systems with zeotropic refrigerants. This also applies to near-azeotropic mixtures.

Temperature glide

During the evaporating process and the condensing process at constant pressure, the refrigerant temperature will decrease in the condenser and rise in the evaporator. Therefore when speaking about evaporating and condensing temperatures, it is important to indicate whether this is a dew point temperature or a mean point value. In the figure below, the dotted lines are lines of constant temperature.

They do not correspond to the lines of constant pressure.

Points A and B are dew point values. These are temperatures on the saturated vapour line.

Points C and D are mean point values. These are temperatures which correspond more or less with the average temperature during the evaporating and condensing process. For the refrigerants with glide of around 10°F, mean point temperatures are typically about 4°F to 5°F lower than dew point temperatures. According to Asercom recommendations, Danfoss Commercial Compressors uses dew point temperatures for selection tables and application envelopes etc.

To obtain exact capacity data at mean point temperatures, the mean point temperatures must be converted to dew point temperatures with help of refrigerant data tables from the refrigerant manufacturer.

Dew temperature and Mean temperature for zeotropic mixtures

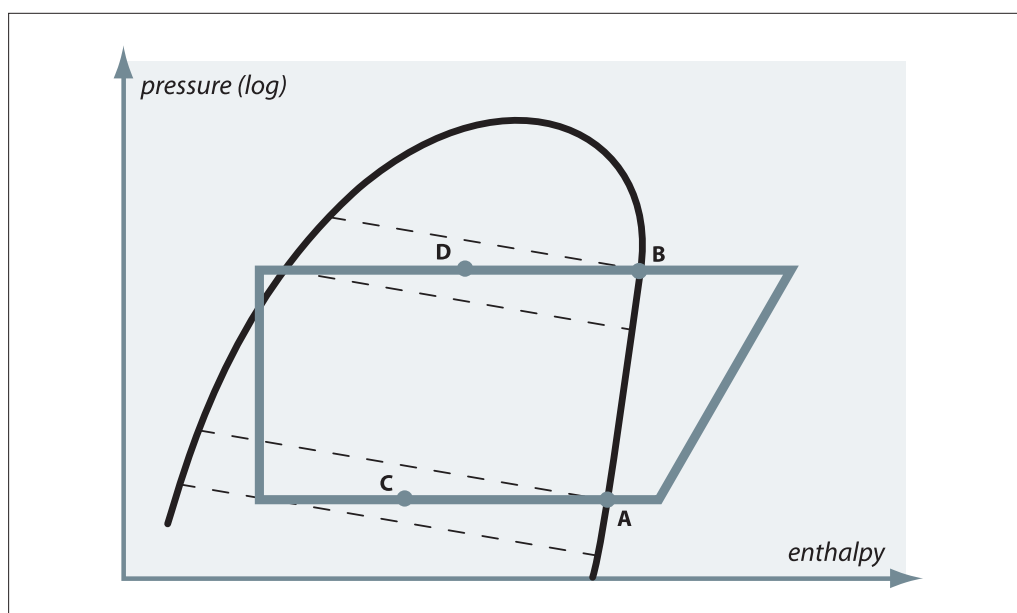

1 cylinder

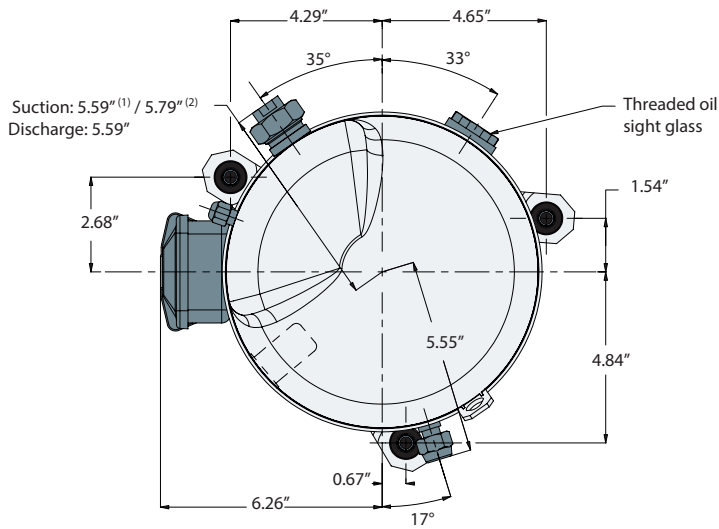
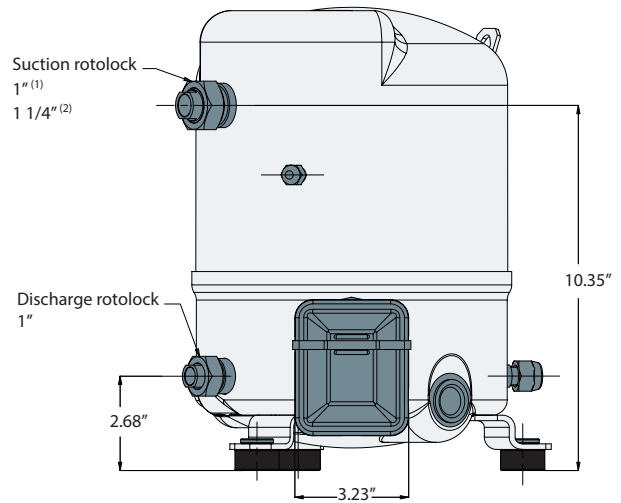
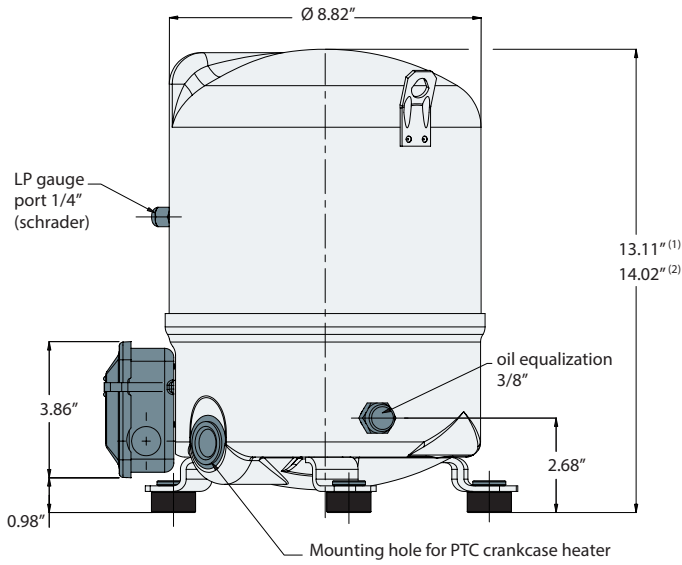

Model	Code								
	1	3	4	5	6	7	9		
MT/MTZ018	(1)	(1)	(1)	(1)	-	-	-		
MT/MTZ022	(2)	(1)	(1)	(1)	(1)	-	(1)		
MT/MTZ028	(2)	(1)	(1)	(1)	(1)	-	(1)		
MT/MTZ032	(2)	(2)	(2)	(2)	(2)	(2)	(2)		
MT/MTZ036	(2)	(2)	(2)	(2)	(2)	(2)	(2)		
MT/MTZ040	(2)	(2)	(2)	-	(2)	-	-		

Silent bloc

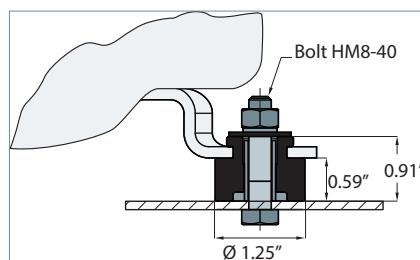

Terminal box

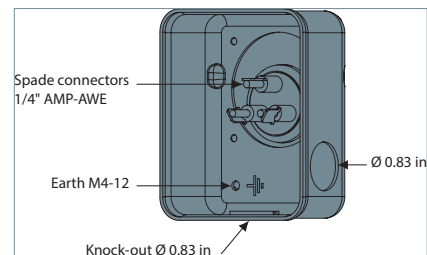

IP rating: 55 (with cable gland)

	Rotolock connections size		Pipe sizing		Rotolock valve	
	Suction	Discharge	Suction	Discharge	Suction	Discharge
MT/MTZ018-022 (3/4/5/6/9)-028 (3/4/5/6)	1"	1"	1/2"	3/8"	V06	V01
MT/MTZ022/1-028/1-032 - 036 - 040	1 1/4"	1"	5/8"	1/2"	V09	V06

2 cylinders

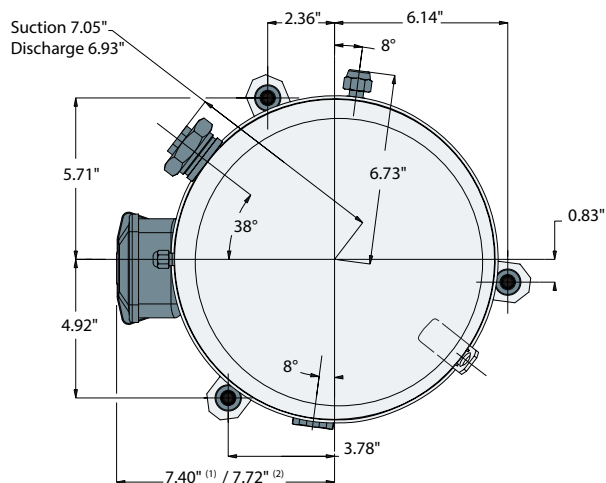
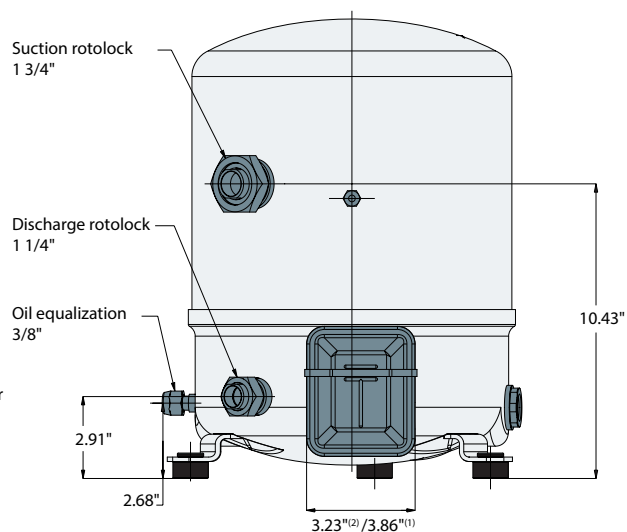
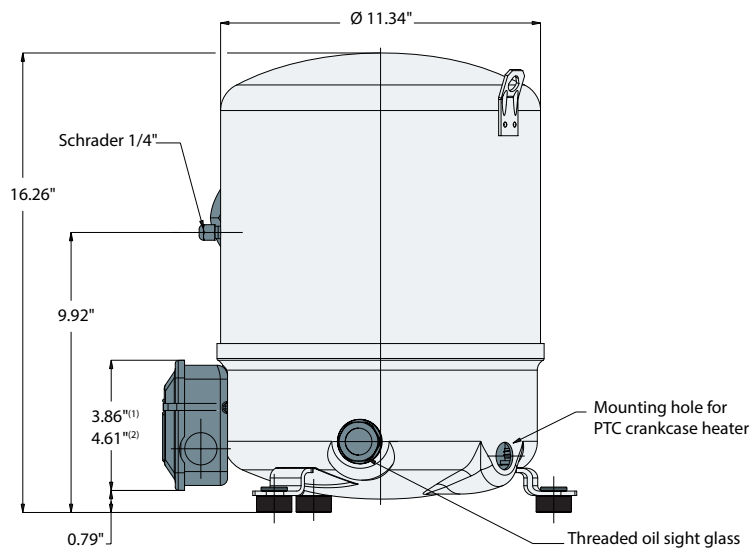

Model	Code					
	1	3	4	6	7	9
MT/MTZ044	(1)	(1)	(1)	(2)	(1)	(1)
MT/MTZ050	(2)	(1)	(1)	(2)	(1)	(1)
MT/MTZ056	(2)	(1)	(1)	(2)	(1)	(1)
MT/MTZ064	(2)	(1)	(1)	(2)	-	(1)
MT/MTZ072	-	(1)	(1)	(2)	-	(1)
MT/MTZ080	-	(2)	(1)	(2)	-	(1)

Terminal box for model (1)

Terminal box for model (2)

Silent bloc

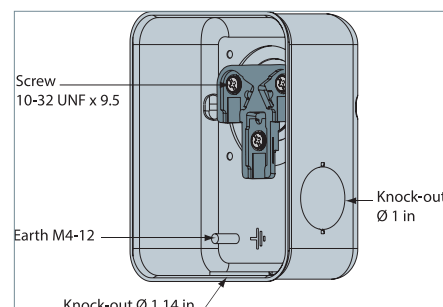
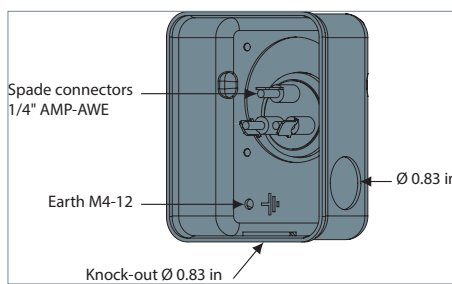
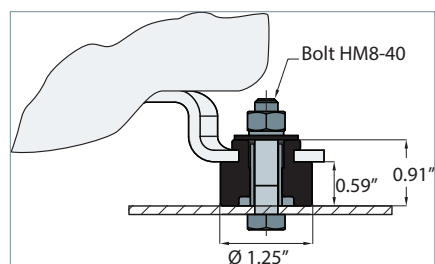

IP rating: 55 (with cable gland)

IP rating: 54 (with cable gland)

	Rotolock connections size		Pipe sizing		Rotolock valve	
	Suction	Discharge	Suction	Discharge	Suction	Discharge
MT/MTZ044 - 050 - 056 - 064 - 072	1 3/4"	1 1/4"	7/8"	3/4"	V07	V04
MT/MTZ080	1 3/4"	1 1/4"	1 1/8"	3/4"	V02	V04

4 cylinders

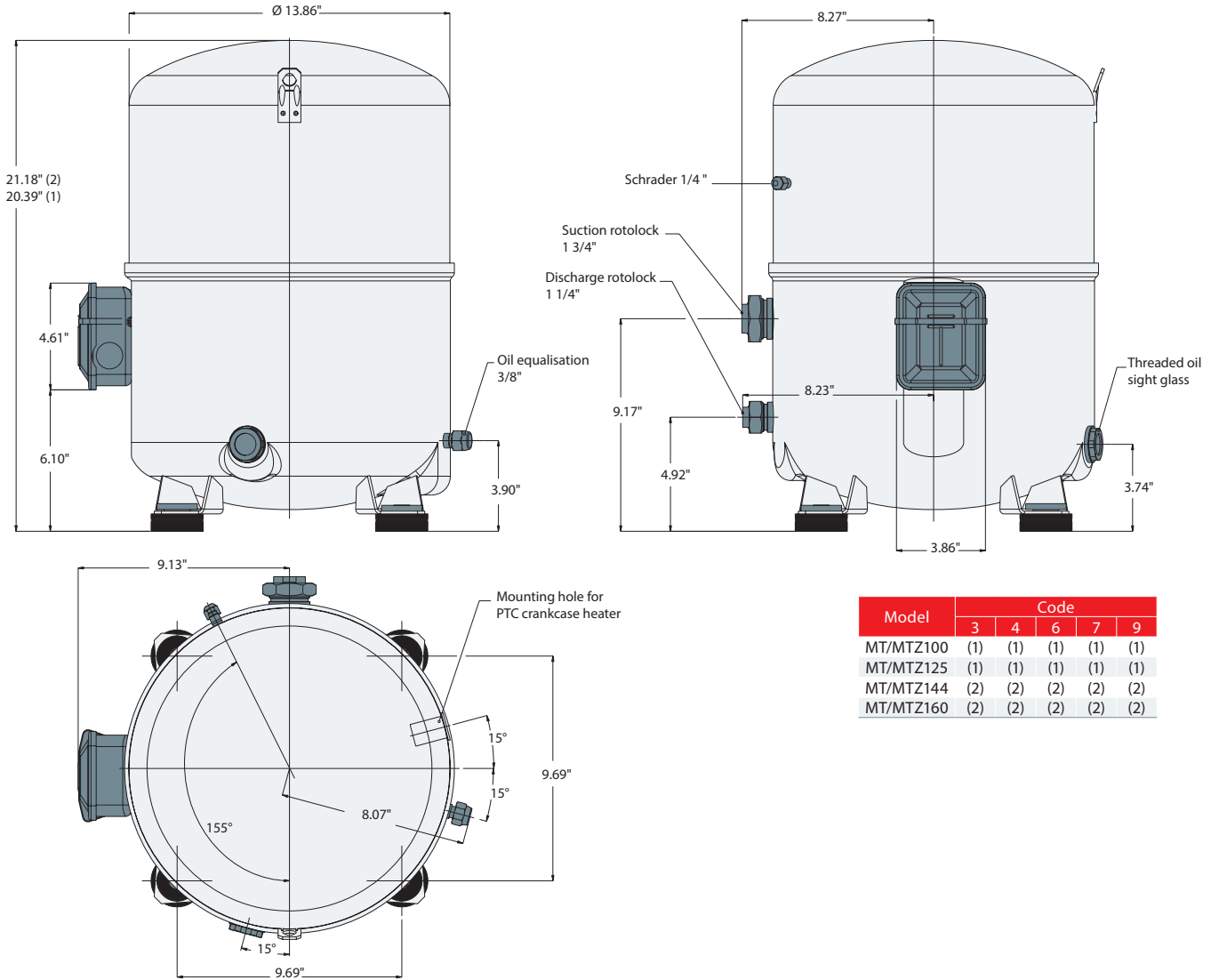

Model	Code				
	3	4	6	7	9
MT/MTZ100	(1)	(1)	(1)	(1)	(1)
MT/MTZ125	(1)	(1)	(1)	(1)	(1)
MT/MTZ144	(2)	(2)	(2)	(2)	(2)
MT/MTZ160	(2)	(2)	(2)	(2)	(2)

Terminal box

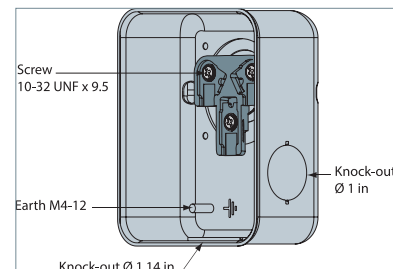
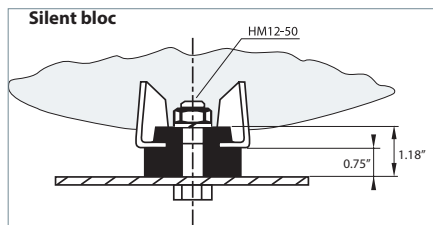

IP rating: 54 (with cable gland)

	Rotolock connections size		Pipe sizing		Rotolock valve	
	Suction	Discharge	Suction	Discharge	Suction	Discharge
MT/MTZ100 - 125 - 144 - 160	1 3/4"	1 1/4"	1 1/8"	3/4"	V02	V04

Single phase electrical characteristics

Motor Code Winding	LRA - Locked Rotor Current (A)		MCC - Maximum Continuous Current (A)		Winding resistance (Ω) (± 7 % at 77°F)			
	1	5	1	5	1		5	
					run	start	run	start
MT/MTZ018	53	40	13	10	1.35	4.25	1.35	3.83
MT/MTZ022	53	41	17	15	1.20	2.31	1.35	3.83
MT/MTZ028	81	51	25	20	0.68	1.84	1.07	3.26
MT/MTZ032	84	70	26.5	20	0.63	2.90	0.80	4.23
MT/MTZ036	84	60	30	22	0.63	2.90	0.80	4.23
MT/MTZ040	99	-	34	-	0.54	1.87	-	-
MT/MTZ044	97	-	31	-	0.46	1.94	-	-
MT/MTZ050	114	-	36	-	0.38	1.83	-	-
MT/MTZ056	136	-	42.5	-	0.33	1.64	-	-
MT/MTZ064	143	-	46	-	0.33	2.14	-	-

Nominal capacitor values and relays

	Models	PSC/CSR*		CSR only	
		Run capacitors (1)		Start capacitors (2)	Start relay
		(A) μF	(C) μF	(B) μF	
50 Hz	MT/MTZ018 JA-5	20	10	100	3ARR3J4A4 /RVA6AMKL
	MT/MTZ022 JC-5	20	10	100	
	MT/MTZ028 JE-5	20	10	100	
	MT/MTZ032 JF-5	25	10	135	
	MT/MTZ036 JG-5	25	10	135	
60 Hz	MT/MTZ018 JA-1	15	10	100	3ARR3J4A4 /RVA6AMKL
	MT/MTZ022 JC-1	30	15	100	
	MT/MTZ028 JE-1	25	25	135	
	MT/MTZ032 JF-1	25	20	100	
	MT/MTZ036 JG-1	25	20	100	
	MT/MTZ040 JH-1	35	20	100	
	MT/MTZ044 HJ-1	30	15	135	
	MT/MTZ050 HK-1	30	15	135	
MT/MTZ056 HL-1	35	20	200		
	MT/MTZ064 HM-1	30	25	235	

* PSC: Permanent Split Capacitor
 CSR: Capacitor Start Run
 (1) Run capacitors: 440 volts
 (2) Start capacitors: 330 Volts

Trickle circuit

The trickle circuit provides the facility of heating the compressor crankcase by feeding a small current to the auxiliary winding and the run capacitor (See the drawings in section “Electrical connections and wiring”).

By using PSC or CSR starting systems, compressor models MT / MTZ 018 - 022 can be operated without crankcase heaters as the heater function is provided by the trickle circuit.

R For the larger single phase compressor models MT / MTZ 028 - 064, the use of the PTC crankcase heater is recommended.

PSC wiring

PSC wiring may be used for refrigerant circuits with capillary tubes or expansion valves with bleed ports. Pressure equalisation must be

ensured before start-up because of the low starting torque characteristics of this system.

CSR wiring

CSR wiring provides additional motor torque at start-up, by the use of a start capacitor in combination with the run capacitor. This system can be used for refrigerant circuits with capillary tubes or expansion valves. The start capacitor is only connected during the starting operation, a potential relay is used to disconnect it after the start sequence.

Some applications with high differential pressure can require a very high starting torque. For such cases the CSR starting kit can be converted to a very high starting torque kit by an additional start capacitor of 100 μF parallel to the start capacitor of the CSR kit. This configuration can also be used to reduce erratic starting at unfavourable conditions such as very low ambient temperature or weak voltage.

Suggested wiring diagrams

Single phase - PSC wiring with trickle circuit

- IOL Motor protector
- A & C Run capacitors
- C Common
- S Start winding (auxiliary)
- R Run winding (main)

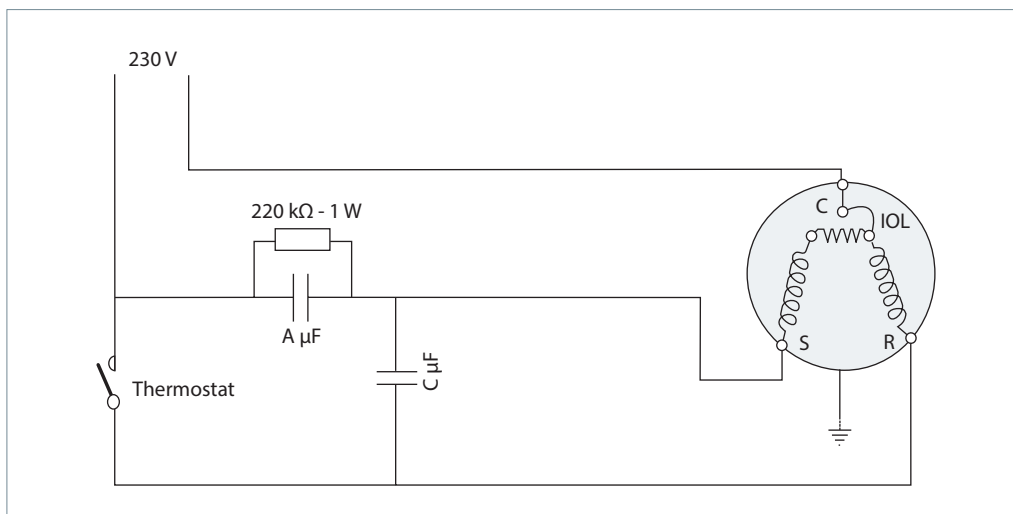

Single phase - CSR wiring with trickle circuit

- IOL Motor protector
- A & C Run capacitors
- B Start capacitor
- C Common
- S Start winding (auxiliary)
- R Run winding (main)

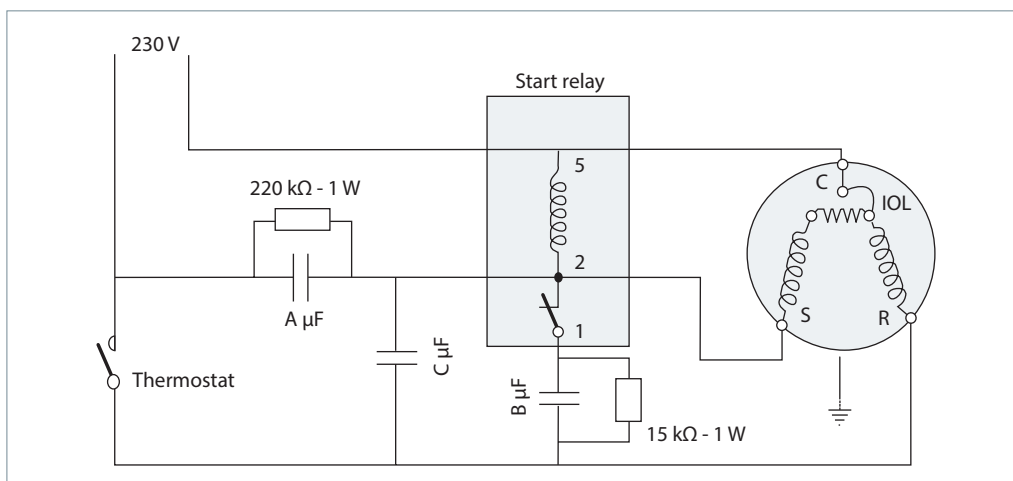

Single phase - CSR wiring without trickle circuit

- IOL Motor protector
 - A+C Run capacitors
 - B Start capacitor
 - C Common
 - S Start winding (auxiliary)
 - R Run winding (main)
- Capacitors A and C can be replaced by a single capacitor of size A + C
 B capacitor delivered in two parts for MT(Z)56 & 64-1

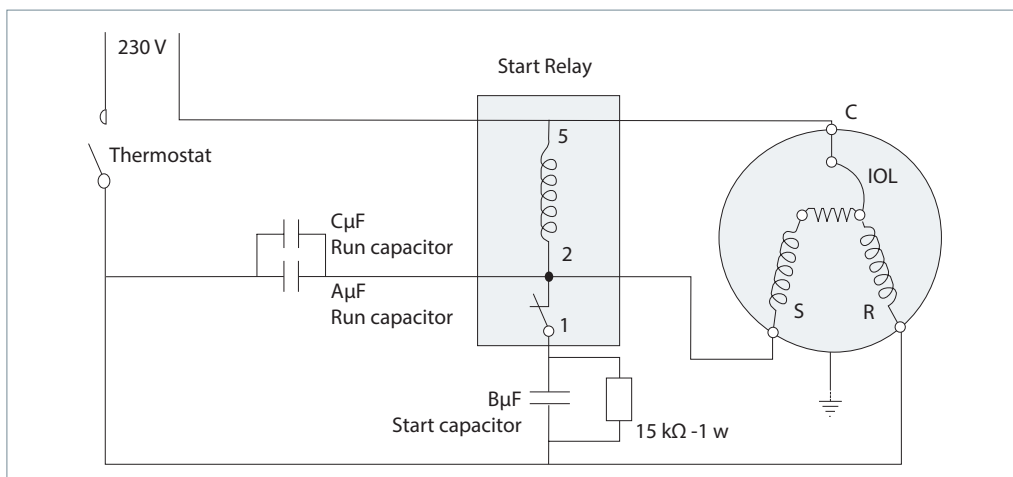

Three phase electrical characteristics

Motor Code	LRA - Locked Rotor Current (A)					MCC - Maximum Continuous Current (A)					Winding resistance (Ω) (± 7% at 77°F)				
	3	4	6	7	9	3	4	6	7	9	3	4	6	7	9
MT/MTZ018	38	20	-	-	-	9.5	5	-	-	-	2.58	9.34	3.41	-	-
MT/MTZ022	38	20	30	-	22.5	11	6	8.5	-	6.5	2.58	11.84	3.41	-	7.30
MT/MTZ028	57	23	41	-	32	16	7.5	11.5	-	8.5	1.41	6.30	1.20	-	4.72
MT/MTZ032	60	25	44	22	35	18	8	13	5.5	9	1.32	4.45	2.01	10.11	3.40
MT/MTZ036	74	38	74	26	35	17	9	17	7	9.5	1.10	5.92	1.10	9.39	-
MT/MTZ040	98	38	74	-	-	22	10	18	-	-	0.89	4.05	1.10	-	-
MT/MTZ044	115	58	77	44	78	26	9.5	16	8.5	13	0.76	3.82	1.15	5.95	1.72
MT/MTZ050	115	58	77	44	78	27	11.5	19	10	13.5	0.74	3.82	1.42	5.95	1.72
MT/MTZ056	130	64	105	50	72	26	14	23	11	15	0.56	2.44	0.78	3.94	1.67
MT/MTZ064	137	64	124	-	72	34	15	25	-	17.5	0.58	2.44	0.78	-	1.67
MT/MTZ072	135	85	143	-	100	35	19	27	-	18.5	0.56	1.85	0.57	-	1.35
MT/MTZ080	140	85	132	-	102	41	19	29	-	22.5	0.49	1.85	0.57	-	1.33
MT/MTZ100	157	90	126	62	110	43	22	35	17	28	0.51	2.12	0.68	3.17	1.36
MT/MTZ 125	210	105	170	75	150	57	27	43	22	30	0.37	1.45	0.44	2.56	0.86
MT/MTZ 144	259	130	208	90	165	64	36	51	25	40	0.28	1.15	0.38	2.04	0.74
MT/MTZ 160	259	130	208	99	165	70	36	51	29	46	0.28	1.15	0.38	1.80	1.12

Winding resistance

Winding resistance is the resistance between indicated terminal pins at 77°F (resistance value +/- 7%).

Winding resistance is generally low and it requires adapted tools for precise measurement.

Motor protection and suggested wiring diagrams

The 3-phase compressors are protected by an internal motor protector, connected to the neutral point of the star connected stator windings, the protector cuts out all 3-phases simultaneously.

Note: once the overload protector has tripped it may take up to 3 hours to reset and restart the compressor.
For all 3-phase compressors, a PTC crankcase heater is required.

Suggested wiring diagram with "one shot" pump-down cycle and safety lock-out relay

- Control device TH
- Optional short cycle timer (3 min) 180 s
- Control relay KA
- Liquid Solenoid valve LLSV
- Compressor contactor KM
- Safety lock out relay KS
- Pump-down control & LP switch LP
- H.P. switch HP
- Fused disconnect Q1
- Fuses F1
- Compressor motor M
- Discharge gas thermostat DGT

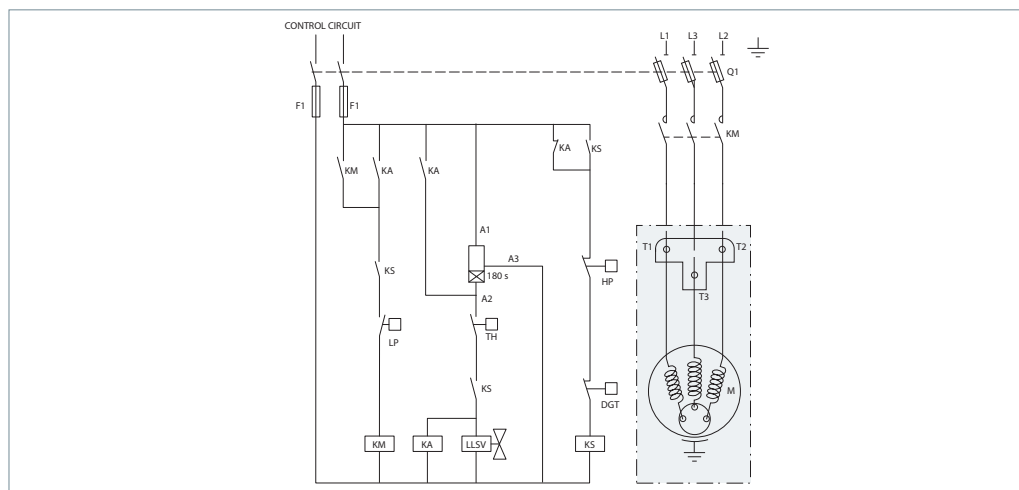

Wiring diagram without pump-down cycle

- Control device TH
- Optional short cycle timer (3 min) 180 s
- Control relay KA
- Compressor contactor KM
- Safety lock out relay KS
- High pressure switch HP
- Low pressure switch LP
- Fused disconnect Q1
- Fuses F1
- Compressor motor M
- Discharge gas thermostat DGT

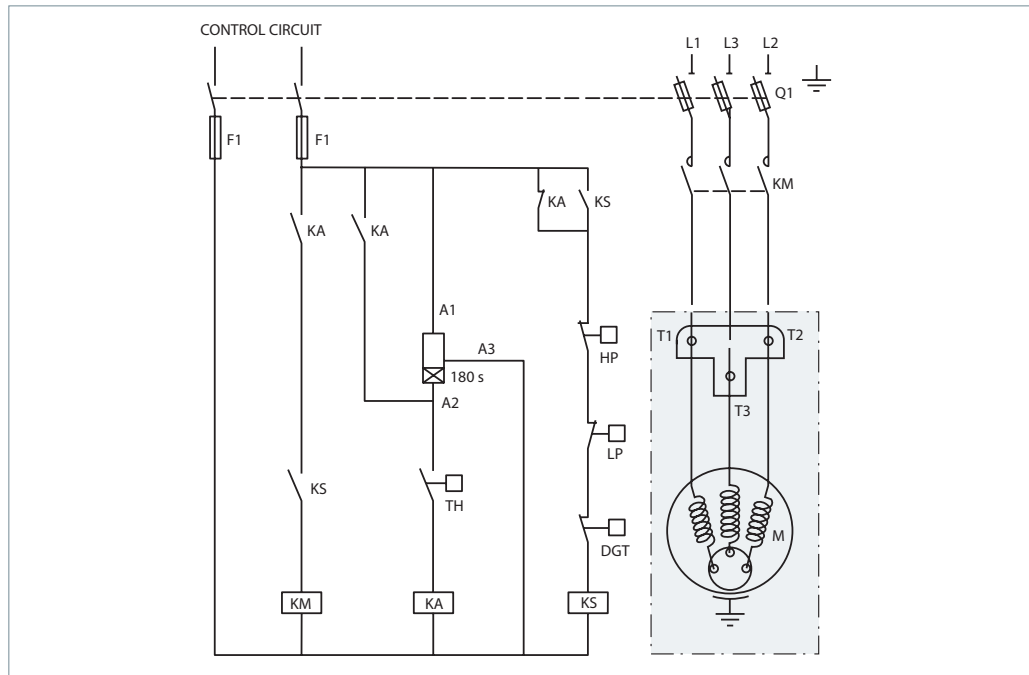

Soft starters

Softstarters are designed to reduce the starting current of 3-phase AC motors.

In case of use with R454A/C or R455A make sure that the softstarter selected is compatible with A2L refrigerants.

Softstarters can be used on MTZ and MT compressor but, in order to ensure proper lubrication of compressor parts, the settings must ensure that the compressor start-up time is always less than 0.5 seconds.

The number of starts should be limited to 6 per hour. HP/LP pressure equalisation is required before starting.

Voltage application range

Motor Code	Nominal voltage	Voltage application range
1	208-230 V / 1 ph / 60 Hz	187 - 253 V
3	200-230 V / 3 ph / 60 Hz	180 - 253 V
4	380-400 V / 3 ph / 50 Hz 460 V / 3 ph / 60 Hz	340 - 440 V 414 - 506 V
5	220-240 V / 1 ph / 50 Hz	198 - 264 V
6	230 V / 3 ph / 50 Hz	207 - 253 V
7	500 V / 3 ph / 50 Hz 575 V / 3 ph / 60 Hz	450 - 550 V 517 - 632 V
9	380 V / 3 ph / 60 Hz*	342 - 418 V

* Some models are approved for 380 - 400 V / 3 ph / 60 Hz. Please check datasheet.

IP rating

The compressor terminal boxes IP rating according to CEI 529 are shown on the outline drawings section.

The IP ratings are only valid when correctly sized cable glands of the same IP rating are applied. Cable glands are not supplied with compressors and need to be purchased at third-party.

IP 5 5

1st numeral, level of protection against contact and foreign objects 5
5 complete protection against contact and against harmful dust deposits

2nd numeral, level of protection against water 5
4 protection against water splashing from any direction
5 protection against jets of water from any direction

MT/ MTZ 1cyl = IP55 -- MT/ MTZ 2 cyl check section outline drawings -- MT/MTZ 4cyl = IP54

General information

When choosing a refrigerant, different aspects must be taken into consideration:

- Legislation (now and in the future)
- Safety
- Application envelope in relation to expected running conditions
- Compressor capacity and efficiency
- Compressor manufacturer recommendations & guidelines

Only Danfoss lubricant are allowed for Maneurop® MT & MTZ compressors.

Additional points could influence the final choice:

- Environmental considerations
- Standardisation of refrigerants and lubricants
- Refrigerant cost
- Refrigerant availability

The table below gives an overview of the different refrigerant - lubricant - compressor combinations for Maneurop® MT & MTZ compressors.

Refrigerant	Type	Lubricant type	Compressor type	Danfoss lubricant	Application
R22	HCFC	Mineral	MT	Mineral oil, 160P	Medium / High temperature
R417A	HFC	Polyolester	MT	Polyolester oil 175PZ	Medium / High temperature
R407A / C / F	HFC	Polyolester	MTZ	Polyolester oil 175PZ	Medium / High temperature
R134a	HFC	Polyolester	MTZ	Polyolester oil 175PZ	Medium / High temperature
R404A	HFC	Polyolester	MTZ	Polyolester oil 175PZ	Medium temperature
R507A	HFC	Polyolester	MTZ	Polyolester oil 175PZ	Medium temperature
R448A /R449A	HFO	Polyolester	MTZ	Polyolester oil 175PZ	Medium/High temperature
R454A/R454C/ R455A	HFO	Polyolester	MTZ	Polyolester oil 175PZ	Medium/High temperature
R452A	HFC+HFO	Polyolester	MTZ	Polyolester oil 175PZ	Medium/High temperature
Alternative R22 retrofit with HFC refrigerants		Polyolester	MT/MTZ	Polyolester oil 175PZ	Medium / High temperature
Hydrocarbons	Danfoss does not authorise the use of hydrocarbons in Maneurop® MT/MTZ compressors				

Capacity and other data for HFC blends refrigerants are not published in this document. Maneurop® compressors however are suitable for use with these refrigerants and can still be used

as replacements in existing installations, see technical news FRCC.EN.049. and FRCC.EN.085. for more information on retrofit.

R22

R22 is an HCFC refrigerant . It has a high GWP and therefore it will be phased out in the future. Check local legislation. Always use mineral oil 160P with R22.

The Maneurop® MT compressor is supplied with an initial mineral oil charge.

Alternatives R22, HFC retrofit

A wide variety of HFC blends exist. There were developed as temporary HCFC and HFC high GWP alternatives. Some examples are R422A/D

- R427A, ... Retrofit technical news have been issued to advice about use of these refrigerants.

R407C

Refrigerant R407C is an HFC refrigerant with similar thermodynamic properties to those of R22.

specific information about zeotropic refrigerants; refer to section "zeotropic refrigerant mixtures". R407C must be charged in the liquid phase.

R407C has zero ozone depletion potential (ODP=0). Many installers and OEMs consider R407C to be the standard alternative for R22. R407C is a zeotropic mixture and has a temperature glide of about 11°F. For more

Always use the Maneurop® MTZ compressors with Danfoss 175PZ polyolester oil, which is supplied with the MTZ compressor.

R134a	<p>Refrigerant R134a is an HFC refrigerant with zero ozone depletion potential (ODP = 0).</p> <p>For applications with high evaporating and high condensing temperatures, R134a is the</p>	<p>ideal choice. R134a is a pure refrigerant and has zero temperature glide. For R134a applications always use the Maneurop® MTZ compressor with Danfoss 175PZ polyolester oil which is supplied with the MTZ compressor.</p>
R404A	<p>Refrigerant R404A is an HFC refrigerant with zero ozone depletion potential (ODP = 0). R404A is especially suitable for low evaporating temperature applications but it can also be applied to medium evaporating temperature applications. R404A is a mixture and has a very small temperature glide, and therefore must be charged in its liquid phase, but for most other aspects this small glide can be neglected. Because of the small glide, R404A is often called</p>	<p>a near-azeotropic mixture. For more information refer to section «zeotropic refrigerant mixtures». For low evaporating temperature applications down to -49°F, Maneurop® NTZ compressors should be used. Refer to the NTZ selection and application guidelines. For medium temperature R404A applications, always use the Maneurop® MTZ compressor with 175PZ polyolester oil which is supplied with the MTZ compressor.</p>
R507A	<p>Refrigerant R507A is an HFC refrigerant with no ozone depletion potential (ODP = 0). As with R404A, R507A is particularly suitable for low evaporating temperature applications but it can also be used for medium evaporating temperature applications. R507A is an azeotropic mixture with no temperature glide. For low</p>	<p>evaporating temperature applications down to -49°F, Maneurop® NTZ compressor should be used. Refer to the NTZ selection and application guidelines. For medium temperature R507A applications, always use the Maneurop® MTZ compressor and Maneurop® 175PZ polyolester oil which is supplied with the MTZ compressor.</p>
R407A	<p>Refrigerant R407A is an HFC with similar thermodynamic properties to those of R404A, R407A is a zeotropic refrigerant and has a temperature glide of about 12°F. For more specific information about zeotropic refrigerant, refer to section “zeotropic refrigerants mixtures”</p>	<p>and read FRCC.EN.085. R407A must be charged in liquid phase, R407A GWP is stated at 2107 [CO₂=1,0]. Always use the Maneurop MTZ compressors with danfoss 175PZ polyolester oil, which is supplied with the MTZ compressors.</p>
R407F	<p>Refrigerant R407F is an HFC with similar thermodynamic properties to those of R404A, R407F is a zeotropic refrigerant and has a temperature glide of about 11,5°F. For more specific information about zeotropic refrigerant, refer to section “zeotropic refrigerants mixtures” and read FRCC.EN.085. R407F must be charged</p>	<p>in liquid phase, R407F GWP is stated at 1825 [CO₂=1,0]. R407F is mainly suitable for high & medium temperature application- Always use the Maneurop MTZ compressors with danfoss 175PZ polyolester oil, which is supplied with the MTZ compressors.</p>
R448A/R449A	<p>R448A/R449A is an HFO/HFC Blend, with similar thermodynamic properties to those of R404A or R22. R448A/R449A is a Zeotropic refrigerant and has a temperature glide of about 11°F. For more specific information about zeotropic refrigerant, refer to section “zeotropic refrigerants mixtures” and read FRCC.EN.085. R448A/R449A must</p>	<p>be charged in liquid phase, R448A GWP is stated at 1387/1397 [CO₂=1,0]. Always use the Maneurop MTZ compressors with Danfoss 175PZ polyolester oil, which is supplied with the MTZ compressors.</p>

Application Guidelines Refrigerants and lubricants

R452A

R452A is an HFO/HFC Blend, with similar thermodynamic properties to those of R404A or R22. R452A is a Zeotropic refrigerant and has a temperature glide of about 7°F. For more specific information about zeotropic refrigerant, refer to section “zeotropic refrigerants mixtures”

and read FRCC.EN.085. R452A must be charged in liquid phase, R452A GWP is stated at 1945 [CO₂=1,0]. Always use the Maneurop® MTZ compressors with Danfoss 175PZ polyolester oil, which is supplied with the MTZ compressors.

R454A/R454C/R455A

R454C/R455A GWP is stated below 150 limit. Because of significant temperature glide, refrigerant must be charged in its liquid phase. Always use the Maneurop MTZ compressors with Danfoss 175PZ polyolester oil..

R454A/R454C/R455A is classified A2L with low flammability properties. Please refer to European regulation and directives about the use of refrigerant of the A2L safety group (EN378, EN60335). Outside Europe refer to the local regulation.

 With R454A/R454C/R455A, liquid migration to the compressor have to be avoid:

- Maintain adequate superheat setting of minimum 15-18°F
- Use solenoid valve on the liquid line and pump down is recommended.
- Use a crankase heater to avoid dissolution of the lubricant.

 All models approved to be used with A2L Refrigerants (belongs to PED classification Group 1) are marked with flammable logo

R513A

R513A is an HFO/HFC Blend, with similar thermodynamic properties to the R134a. R513A is a Azeotrope refrigerant with a negligible glide.

R513A has zero ozone depletion potential (ODP=0) and a Global Warming Potential (AR5) at 573 [CO₂=1] . Always use the Maneurop® MTZ compressors with Danfoss 175PZ polyolester oil.

 With R513A, liquid migration to the compressor have to be avoid:

- Maintain adequate superheat setting of minimum 15-18°F
- Use solenoid valve on the liquid line and pump down is recommended.
- Use a crankase heater to avoid dissolution of the lubricant.

Hydrocarbons

Hydrocarbons such as propane, isobutane etc. are extremely flammable. Danfoss does not authorise the use of hydrocarbons with

Maneurop® MT or MTZ compressors in any way, even with a reduced refrigerant charge.

Piping design

Oil in a refrigeration circuit is required to lubricate moving parts in the compressor. During normal system operation small oil quantities will continuously leave the compressor, with the discharge gas. With good system piping design this oil will return to the compressor. As long as the amount of oil circulating through the system is small it will contribute to good system operation and improved heat transfer efficiency. However, too large amounts of oil in the system will have a negative effect on condenser and evaporator efficiency. If, in a poorly designed

system, the amount of oil returning to the compressor is lower than the amount of oil leaving the compressor, the compressor will become starved of oil and the condenser, evaporator and/or refrigerant lines will become filled with oil. In such situations, additional oil charge will only correct the compressor oil level for a limited period of time and increase the amount of surplus oil in the rest of the system.

Only correct piping design can ensure a good oil balance in the system.

Suction lines

Horizontal suction line sections shall have a slope of 0.5% in the direction of refrigerant flow (5/8" per 10 ft of pipe). The cross-section of horizontal suction lines shall be such that the resulting gas velocity is at least 13 ft/s. In vertical risers, a gas velocity of 26 to 40 ft/s is required to ensure proper oil return. A U-trap is required at the foot of each vertical riser. If the riser is higher than 13 ft, additional U-traps are required for each additional 4 ft. The length of each U-trap must be as short as possible to avoid the accumulation of excessive quantities of oil (see figure below).

For compressors mounted in parallel, the common suction riser should be designed as a double riser. Also refer to the News bulletin "Mounting instructions for installation of Maneurop® compressors in parallel " and "Parallel application guidelines".

Gas velocities higher than 40 ft/s will not

contribute to significantly better oil return. However they will cause higher noise levels and result in higher suction line pressure drops which will have a negative effect on the system capacity.

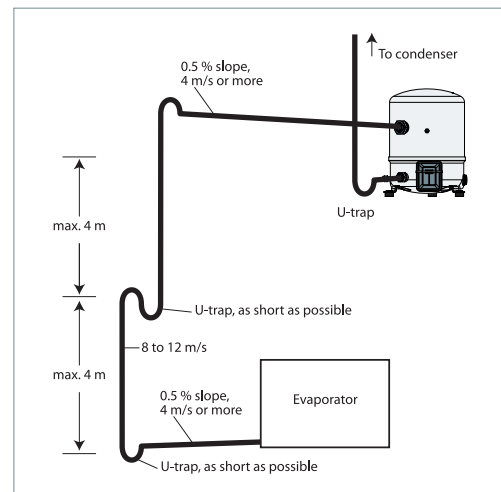

Note that the suction rotolock valves, which can be ordered from Danfoss as accessories, are designed for average pipe sizes, selected for systems running at nominal conditions.

The pipe sizes selected for specific systems may differ from these recommended sizes.

It is recommended that the suction lines are insulated to limit suction gas superheat.

Discharge line

When the condenser is mounted above the compressor, a loop above the condenser and a U-trap close to the compressor are required to prevent liquid draining from the condenser into the discharge line during standstill.

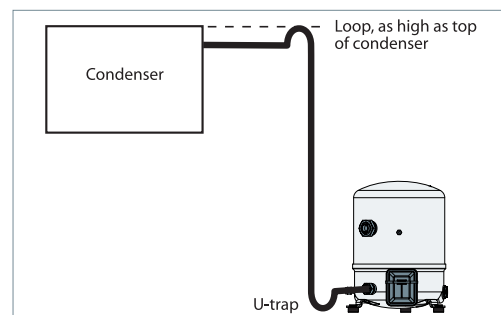

Application Guidelines

System design recommendations

Oil charge and oil separator

In most installations the initial compressor oil charge will be sufficient. In installations with line runs exceeding 66 ft, or with many oil traps or an oil separator, additional oil may be required. In

installations with the risk of slow oil return such as in multiple evaporator or multiple condenser installations, an oil separator is recommended.

Filter driers

For new installations with MTZ compressors Danfoss recommends using the Danfoss DML 100%-molecular sieve, solid core filter drier. Molecular sieve filter driers with loose beads from third party suppliers shall be avoided.

filter driers containing activated alumina are recommended.

For servicing of existing installations where acid formation is present the Danfoss DCL solid core

The drier is to be oversized rather than undersized. When selecting a drier, always take into account its capacity (water content capacity), the system refrigerating capacity and the system refrigerant charge.

Operating limits

High pressure

A high pressure safety switch is required to stop the compressor, should the discharge pressure exceed the values shown in the table below. The high pressure switch can be set to lower values depending on the application and ambient conditions.

R The HP switch must either be in a lockout circuit, or be a manual reset device to prevent compressor cycling around the high pressure limit. When a discharge valve is used, the HP switch must be connected to the service valve gauge port, which cannot be isolated.

Low pressure

R A low pressure safety switch is recommended to avoid compressor operation at too lower suction pressures.

	MT						MTZ						
	R22 160P	R417A 175PZ	R407A 175PZ	R407C 175PZ	R407F 175PZ	R134a 175PZ	R404A/ R507A 175PZ	R452A 175PZ	R448A/ R449A 175PZ	R513A 175PZ	R454A 175PZ	R454C 175PZ	R455A 175PZ
	psi(g)												
Test pressure low side	360	360	360	360	360	360	360	360	360	360	360	360	360
Working pressure range high side (dew)	158-402	135-370	167-374	180-425	175-348	113-328	104-402	97-394	88-378	51-336	94-390	75-329	83-352
Working pressure range low side (dew)	15-100	3-81	7-86	20-94	15-90	0-68	15-104	12-97	9-88	3-74	10-94	6-75	7-83
*Relief valve opening pressure difference	435	435	435	435	435	435	435	435	435	435	435	435	435
*Relief valve closing pressure difference	115	115	115	115	115	115	115	115	115	115	115	115	115

* Relief valve fitted on 2 and 4 cyl.

Low ambient temperature operation

At low ambient temperatures, the condensing temperature and condensing pressure in air cooled condensers will decrease.

valve in the discharge line is required and special care should be taken when designing the discharge line.)

- Reduce air flow to condensers.

This low pressure may be insufficient to supply enough liquid refrigerant to the evaporator. As a result the evaporator temperature will strongly decrease with the risk of frosting. At compressor start-up, the compressor can pull a deep vacuum and it can be switched off by the low pressure protection. Depending on the low pressure switch setting and delay timer short cycling can occur. To avoid these problems, several solutions are possible, based on reducing condenser capacity:

Other problems can also occur when the compressor is operating at low ambient temperature. During shut down periods, liquid refrigerant can migrate to a cold compressor.

- Indoor location of condensers
- Liquid flooding of condensers (note: this solution requires extra refrigerant charge, which can introduce other problems. A non-return

For such conditions a belt-type crankcase heater is strongly recommended.

Note that with 100% suction gas cooled motors, Maneurop® compressors can be externally insulated.

Refer to section "Liquid refrigerant control & charge limits" for more details.

Operating voltage and cycle rate

Operating voltage range

The operating voltage limits are shown in the table from section “Compressor model designation”. The voltage applied to the motor terminals must always be within these table limits. The maximum allowable voltage

unbalance for 3-phase compressors is 2%. Voltage unbalance causes high current draw on one or more phases, which in turn leads to overheating and possible motor damage. Voltage unbalance is given by the formula:

$$\% \text{ voltage unbalance: } \frac{|V_{avg} - V_{1-2}| + |V_{avg} - V_{1-3}| + |V_{avg} - V_{2-3}|}{2 \times V_{avg}} \times 100$$

Vavg = Mean voltage of phases 1, 2 and 3
V1-2 = Voltage between phases 1 and 2

V1-3 = Voltage between phases 1 and 3
V2-3 = Voltage between phases 2 and 3.

Cycle rate limit

R There may be no more than 12 starts per hour (6 when a soft start accessory is used). A higher number reduces the service life of the motor-compressor unit. If necessary, use an anti-short-cycle timer in the control circuit. A time-out of six minutes is recommended.

The system must be designed in such a way to guarantee a minimum compressor running time in order to provide proper oil return and sufficient motor cooling after starting. Note that the oil return rate varies as a function of the system design.

Liquid refrigerant control and charge limit

Refrigeration compressors are basically designed as gas compressors. Depending on the compressor design and operating conditions, most compressors can also handle a limited amount of liquid refrigerant. Maneurop® MT and MTZ compressors have a large internal volume and can therefore handle relatively large amounts of liquid refrigerant without major problems. However even when a compressor can handle liquid refrigerant, this will not be favourable to its service life. Liquid refrigerant can dilute the oil, wash oil out of bearings and result in high oil carry over, resulting in loss of

oil from the sump. Good system design can limit the amount of liquid refrigerant in the compressor, which will have a positive effect on the compressor service life.

Liquid refrigerant can enter a compressor in different ways, with different effects on the compressor.

R The liquid migration to the compressor must be avoided by maintaining adequate superheat setting of min. 15-18 °F.

Off-cycle migration

During system standstill and after pressure equalisation, refrigerant will condense in the coldest part of the system. The compressor can easily be the coldest spot, for example when it is placed outside in low ambient temperatures. After a while, the full system refrigerant charge can condense in the compressor crankcase. A large amount will dissolve in the compressor oil until the oil is completely saturated with refrigerant. If other system components are located at a higher level, this process can be even faster because gravity will assist the liquid refrigerant to flow back to the compressor. When the compressor is started, the pressure in the crankcase decreases rapidly.

At lower pressures the oil holds less refrigerant, and as a result part of the refrigerant will violently evaporate from the oil, causing the oil to foam. This process is often called “boiling”.

The negative effects from migration on the compressor are:

- oil dilution by liquid refrigerant
- oil foam, transported by refrigerant gas and discharged into the system, causing loss of oil and in extreme situations risk for oil slugging
- in extreme situations with high system refrigerant charge, liquid slugging could occur (liquid entering the compressor cylinders).

Liquid floodback during operation



During normal and stable system operation, refrigerant will leave the evaporator in a superheated condition and enter the compressor as a superheated vapour.

refrigerant due to different reasons:

- wrong dimensioning, wrong setting or malfunction of expansion device
- evaporator fan failure or blocked air filters.

Normal superheat values at compressor suction are 9 to 54°F. However the refrigerant leaving the evaporator can contain an amount of liquid

In these situations, liquid refrigerant will continuously enter the compressor.

	<p>The negative effects from continuous liquid floodback are:</p> <ul style="list-style-type: none"> • permanent oil dilution 	<ul style="list-style-type: none"> • in extreme situations with high system refrigerant charge and large amounts of floodback, liquid slugging could occur.
Liquid floodback at change over cycles in reversible heat pumps	<p>In heat pumps, change over from cooling to heating cycles, defrost and low load short cycles may lead to liquid refrigerant floodback or saturated refrigerant return conditions.</p>	<p>The negative effects are:</p> <ul style="list-style-type: none"> • oil dilution • in extreme situations with high system refrigerant charge and large amounts of floodback, liquid slugging could appear.
Liquid floodback and zeotropic refrigerants	<p>Liquid floodback in systems working with a zeotropic refrigerant introduces additional negative effects. e.g. R407C, R454A/C, R455A. A part of the refrigerant leaves the evaporator in liquid phase and this liquid has a different composition than the vapour.</p>	<p>This new refrigerant composition may result in different compressor operating pressures and temperatures.</p>
Crankcase heater	<p> A crankcase heater protects against the off-cycle migration of refrigerant and proves effective if oil temperature is maintained 18°F above the saturated LP temperature of the refrigerant. Tests must thereby be conducted to ensure that the appropriate oil temperature is maintained under all ambient conditions. A PTC crankcase heater is recommended on all stand-alone compressors and split systems. PTC crankcase heaters are self-regulating.</p> <p>Under extreme conditions such as very low ambient temperature a belt type crankcase heater could be used in addition to the PTC heater, although this is not a preferred solution for 1 and 2 cylinder compressors. The belt crankcase heater must be positioned on the compressor shell as close as possible to the oil sump to ensure good heat transfer to the oil.</p>	<p>Belt crankcase heaters are not self-regulating. Control must be applied to energise the belt heater once the compressor has been stopped and then to de-energise it while the compressor is running. The belt heater must be energised 12 hours before restarting the compressor following an extended down period.</p> <p>If the crankcase heater is not able to maintain the oil temperature at 18°F above the saturated LP temperature of the refrigerant during off cycles or if repetitive floodback is present a the Liquid Line Solenoid Valve (LLSV) + pump-down cycle is required, eventually in conjunction with a suction accumulator.</p> <p> Crankcase heater or PTC crankcase heater always has to be use when refrigerant R454A, R454C,R455A or R513A is used.</p>
Liquid line solenoid valve & pump-down	<p>In refrigeration applications, the Liquid Line Solenoid Valve (LLSV) is highly recommended. During the off-cycle, the LLSV isolates the liquid charge in the condenser side, thus preventing against refrigerant transfer or excessive migration of refrigerant into the compressor. Furthermore, when using a LLSV in conjunction with a pump-down cycle, the quantity of refrigerant in the low-pressure side of the system will be reduced.</p>	<p>A pump-down cycle design is required when evaporators are fitted with electric defrost heaters.</p> <p>Liquid line solenoid valve and pump down have to be use with refrigerant R513A.</p>
Suction accumulator	<p>A suction accumulator offers considerable protection against refrigerant floodback at start-up, during operation or after the defrost operation. This device also helps to protect against off-cycle migration by means of providing additional internal free volume to the low pressure side of the system.</p>	<p>The suction accumulator must be selected in accordance with the accumulator manufacturer recommendations. As a general rule, Danfoss recommends to size the accumulator for at least 50% of the total system charge. Tests however must be conducted to determine the optimal size.</p>

Sound

Running compressors cause sound and vibration. Both phenomena are closely related.

Sound produced by a compressor is transmitted in every direction by the ambient air, the mounting feet, the pipework and the refrigerant in the pipework.

The easiest way to reduce the sound transmitted through ambient air is to fit a Danfoss acoustic hood accessory.

Because Maneurop® compressors are 100% suction gas cooled, and require no body cooling, they can be insulated. Values for the sound reduction achieved with acoustic hoods are shown also in the table on the right. For inside mounted compressors, sound insulation of the plantroom is an alternative to sound insulation of the compressor.

Sound transmitted by mounting feet, pipework and refrigerant should be treated the same way as for vibration. Please refer to the next section.

50Hz	Te=14°F / TC=113°F / SH=18°F						Acoustic hood accessory**
	R404A	R448A	R449A	R452A	R454A/ R454C/ R455A	R513A	
MTZ018-4	73	74	73	76	75	71*	120Z0575
MTZ022-4	74	74	74	74	75	69*	
MTZ028-4	75	72	73	73	75	68*	
MTZ032-4	73	73	73	73	72	68*	
MTZ036-4	72	72	72	72	73	67*	
MTZ040-4	72	73	75	72	73	67	120Z0576
MTZ044-4	80	80	80	80	-	76*	
MTZ050-4	83	83	83	83	-	79*	
MTZ056-4	81	81	80	79	-	75*	
MTZ064-4	80	80	80	80	-	76*	
MTZ072-4	79	79	79	79	-	75*	120Z0577
MTZ080-4	80	80	79	80	-	76	
MTZ100-4	85	84	84	82	-	79*	
MTZ125-4	84	84	84	84	-	81*	
MTZ144-4	83	83	83	83	-	80*	
MTZ160-4	83	84	83	81	-	78	

60Hz	Te=14°F / TC=113°F / SH=18°F						Acoustic hood accessory**
	R404A	R448A	R449A	R452A	R454A/ R454C/ R455A	R513A	
MTZ018-4	76	75	73	76	72	71*	120Z0575
MTZ022-4	77	77	77	77	77	72*	
MTZ028-4	74	73	74	73	76	68*	
MTZ032-4	74	74	74	74	73	69*	
MTZ036-4	73	73	73	73	76	68*	
MTZ040-4	75	73	74	74	74	69	120Z0576
MTZ044-4	83	81	82	81	-	77*	
MTZ050-4	86	86	86	86	-	82*	
MTZ056-4	84	84	84	84	-	76*	
MTZ064-4	83	83	83	83	-	78*	
MTZ072-4	82	82	82	82	-	77*	120Z0577
MTZ080-4	82	81	80	82	-	77	
MTZ100-4	88	86	86	85	-	81*	
MTZ125-4	87	87	87	87	-	83*	
MTZ144-4	86	86	86	86	-	82*	
MTZ160-4	86	85	84	84	-	80	

* Provisional Data

Sound power level for MTZ

As first approach, use these figures with -3 dB(A) reduction on the R404A sound power for MT models applied with R22.

** Acoustic hood accessory can reduce noise level by 6 to 10 dBA (depending on the operating conditions and models).

Vibration

The mounting grommets delivered with the compressor should always be used. They reduce the vibration transmitted by the compressor mounting feet to the base frame.

The base on which the compressor is mounted should be sufficiently rigid and of adequate mass to ensure the full effectiveness of the mounting grommets.

The compressor should never be directly mounted to the base frame without the grommets, otherwise high vibration transmission would occur and the compressor service life reduced. Suction and discharge lines must have adequate flexibility in 3 planes. Eventually vibration absorbers may be required.

Care must be taken to avoid tubing having resonant frequencies close to those of the compressor frequency.

Vibration is also transmitted by the refrigerant gas. Maneurop® compressors have built in mufflers to reduce this vibration.

To further reduce vibration an extra muffler can be installed.

Note: Maneurop® MT & MTZ compressors have been designed and qualified for stationary equipment used in A/C and Refrigeration applications.

Danfoss doesn't warrant these compressors for use in mobile applications, such as trucks, railways, subways, etc...

System cleanliness

System contamination is one of the main factors affecting equipment reliability and compressor service life.

Therefore it is important to ensure system cleanliness when manufacturing a refrigeration system. During the manufacturing process, system contamination can be caused by:

- Brazing and welding oxides
- Filings and particles from removing burrs from pipe-work
- Brazing flux
- Moisture and air.

Only use clean and dehydrated refrigeration grade copper tubes and silver alloy brazing

material. Clean all parts before brazing and always purge nitrogen or CO₂ through the pipes during brazing to prevent oxidation. If flux is used, take every precaution to prevent leakage into the piping. Do not drill holes (e.g. for schröder valves) in parts of the installation that are already completed, when filings and burrs can not be removed. Carefully follow the instructions below regarding brazing, mounting, leak detection, pressure test and moisture removal. All installation and service work shall only be done by qualified personnel respecting all procedures and using tools (charging systems, tubes, vacuum pump, etc.) dedicated for the refrigerant that will be used.

Compressor handling, mounting and connection to the system
Compressor handling

Maneurop® MT and MTZ compressors are provided with a lifting lug. This lug should always be used to lift the compressor. Once the compressor is installed, the compressor lifting

lug should never be used to lift the complete installation. Keep the compressor in an upright position during handling.

Compressor mounting

Mount the compressor on a horizontal plane with a maximum slope of 3 degrees. All compressors are supplied with three or four rubber mounting grommets, each complete with metal sleeves and nuts and bolts. Refer to the section "Outline drawings".

These grommets largely attenuate the compressor vibration transmitted to the base frame. The compressor must always be mounted with these grommets. Refer to the table below for torque values.

Designation		Recommended torque (lbf.ft)
Cable screw of T connector in electrical box	screw 10/32 - UNF x 3	2
Rotolock valves and solder sleeves	1"	59
	1"1/4	44
	1"3/4	81
Mounting grommet bolts	1-2 / 4 cylinder	11/37
Oil sight glass	-	37
Oil equalisation connection	1-2 / 4 cylinder	22/33

Compressor connection to the system

New compressors have a protective nitrogen holding charge.

The suction and discharge caps should only be removed just before connecting the compressor to the installation to avoid air and moisture entering the compressor.

Whenever possible the compressor must be the last component to be integrated in the system. It is advisable to braze the solder sleeves or service

valves to the pipework before the compressor is mounted. When all brazing is finished and when the total system is ready, the compressor caps can be removed and the compressor can be connected to the system with a minimum exposure to ambient air.

If this procedure is not possible, the sleeves or valves may be brazed to the pipes when mounted on the compressor.

In this situation nitrogen or CO₂ must be purged through the compressor via the schrader valve to prevent air and moisture ingress. Purging must start when the caps are removed and proceeded during the brazing process.

When rotolock valves are used on the compressor, they shall be closed immediately after mounting, thus keeping the compressor isolated from atmosphere or from a not yet dehydrated system.

Note: When the compressor is built into a "pack" or "rack" configuration which is not installed immediately on its final location, a vacuum pull-down and moisture removal must be performed to this pack (rack) as if it were a complete system (see below). The pack must be charged with nitrogen or CO₂ and open tubes must be blocked with caps or plugs.

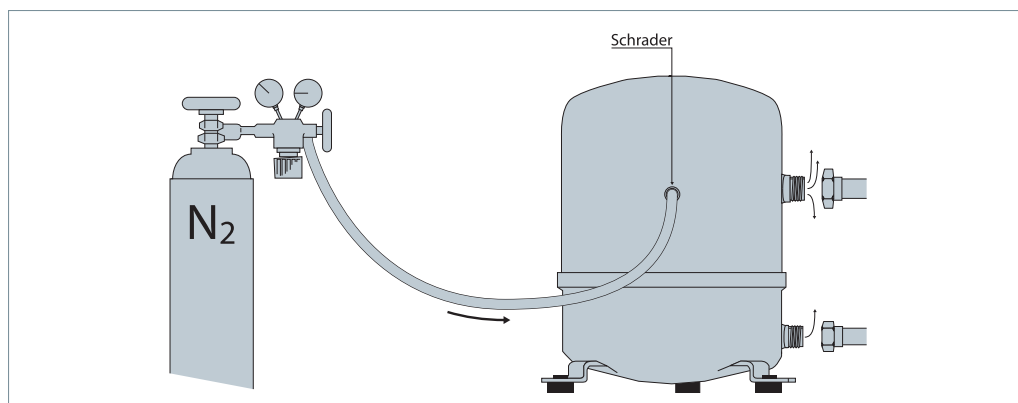

System pressure test

It is recommended that an inert gas such as nitrogen be used for pressure testing. Dry air may also be used but care should be taken since it can form an inflammable mixture with the compressor oil. When performing a system pressure test, the maximum allowed pressure for the different components should not be exceeded.

For MT/MTZ compressors the maximum test pressures are shown in the table beside.

	1-2-4 cylinder compressors
Maximum compressor test pressure, low side	362psi(g)
Maximum compressor test pressure, high side	435psi(g)

Do not exceed 30 bar pressure difference between high pressure side and low pressure side of the compressor because this will open the internal compressor relief valve.

Leak detection

Whenever possible (if valves are present) the compressor must be kept isolated from the system. Perform a leak detection using the final refrigerant. Pressurise with nitrogen or another neutral gas and use a leak detector for the applied refrigerant. Any spectrometric detection system using helium can also be applied.

Eventual leaks shall be repaired respecting the instructions written above. It is not recommended to use other gasses such as oxygen, dry air or acetylene as these gasses can form an inflammable mixture. Never use CFC

or HCFC refrigerants for leak detection of HFC systems.

Note 1: Leak detection with refrigerant may not be allowed in some countries. Check local regulations.

Note 2: Leak detecting additives shall not be used as they may affect the lubricant properties.

Warranty may be voided if leak detecting additives have been used.

Vacuum pull-down moisture removal

Moisture obstructs the proper functioning of the compressor and the refrigeration system.

Air and moisture reduce service life and increase condensing pressure, and cause excessively high discharge temperatures, which can destroy the

lubricating properties of the oil. Air and moisture also increase the risk of acid formation, giving rise to copper plating. All these phenomena can cause mechanical and electrical compressor failure.

To eliminate these factors, a vacuum pull-down according to the following procedure is recommended:

- ① Whenever possible (if valves are present) the compressor must be kept isolated from the system.
- ② After the leak detection, the system must be pulled-down under a vacuum of 500 microns (0.67 mbar). A two stage vacuum pump shall be used with a capacity appropriate to the system volume. It is recommended to use connection lines with a large diameter and to connect these to the service valves and not to the schrader connection to avoid too high pressure losses.
- ③ When the vacuum level of 500 micron is reached, the system must be isolated from the vacuum pump. Wait 30 minutes during which the system pressure should not rise. When the pressure rapidly increases, the system is not leak tight.

A new leak detection must be performed and the vacuum pull-down procedure should be restarted from step 1. When the pressure slowly increases, this indicates the presence of moisture. In this case step 2 and 3 should be repeated.

- ④ Connect the compressor to the system by opening the valves. Repeat step 2 and 3.
- ⑤ Break the vacuum with nitrogen or the final refrigerant.
- ⑥ Repeat step 2 and 3 on the total system.

At commissioning, system moisture content may be up to 100 ppm. During operation the filter drier must reduce this to a level < 20 ppm.

Do not use a megohmmeter or apply power to the compressor while it is under vacuum, as this may cause motor winding damage.

Never run the compressor under vacuum as it may cause compressor motor burn-out.

Start-up

Before initial start-up or after a prolonged shut down period, energise the crankcase heater (if fitted) 12 hours prior to start-up, or turn on

power for single phase compressors with trickle circuit.

Refrigerant charging

Zeotropic and «near-azeotropic» refrigerant mixtures such as R404A, R407A/C/F, R448A, R449A, R454A/C and R455A must always be charged in the liquid phase. For the initial charge, the compressor must not run and service valves must be closed. Charge refrigerant as close as possible to the nominal system charge before starting the compressor. Then slowly add refrigerant in the liquid phase, on the low pressure side as far away as possible from the running compressor.

The refrigerant charge quantity must be suitable for both winter and summer operation. Refer also to section "Protection against flooded starts and liquid floodback" for information about refrigerant charge limits.

when a liquid line solenoid valve is used, the vacuum in the low pressure side must be broken before applying power to the system.

Oil charge and oil level

The oil charge must be checked before commissioning (1/4 to 3/4 of the oil sight glass). Check the oil level again after a minimum of 2 hours operation at nominal conditions. In most installations the initial compressor oil charge will be sufficient. In installations with line runs exceeding 66ft or with many oil traps or an oil separator, additional oil may be required. Normally the quantity of oil added should be no more than 2% of the total refrigerant charge (this percentage does not take into account oil

contained in accessories such as oil separators or oil traps). If this amount has already been added and the oil level in the compressor keeps decreasing, the oil return in the installation is insufficient. Refer also to section "Piping design".

In installations where slow oil return is likely such as in multiple evaporator or multiple condenser installations, an oil separator is recommended. Refer to the table section "Refrigerant and lubricants" to select the correct oil.

Suction gas superheat

The optimum suction gas superheat is 18°F. A lower superheat value will contribute to better system performance (higher mass flow and more efficient use of evaporator surface). Low superheat values however increase the risk of unwanted liquid floodback to the compressor.

For very low superheat values an electronically controlled expansion valve is recommended.

The maximum allowable superheat is about 30 K. Higher values can be accepted but in these cases, tests have to be performed to check that the maximum discharge temperature of 266°F will not be exceeded. Note that high superheat values decrease the compressor application envelope and system performance.

Packaging



Model	Single pack		Multipack				Industrial pack			
	Dimensions (in)	Gross weight (lbs)	Nbr	Dimensions (in)	Gross weight (lbs)	Static stacking	Nbr	Dimensions (in)	Gross weight (lbs)	Static stacking
MT/MTZ 018		50.7			435				613	
MT/MTZ 022		50.7			435				613	
MT/MTZ 028	l: 13.0	55.1	8	l: 45.3	470	4	12	l: 45.3	666	4
MT/MTZ 032	w: 11.6	57.3		w: 31.5	487			w: 31.5	693	
MT/MTZ 036	h: 15.2	59.5		h: 20.1	505			h: 19.7	719	
MT/MTZ 040		59.5			505				719	
2 cylinders	MT/MTZ 044-050	86.0	6	l: 45.3	538	4	6	l: 45.3	520	4
	MT/MTZ 056-064	90.4		w: 31.5	565			w: 31.5	547	
	MT/MTZ 072-080	94.8		h: 23.6	591			h: 23.6	573	
4 cylinders	MT/MTZ 100	154.4			642				840	
	MT/MTZ 125	l: 18.5	4	l: 45.3	668	4	6	l: 45.3	880	4
	MT/MTZ 144	w: 15.7		w: 31.5	695			w: 31.5	920	
	MT/MTZ 160	h: 25.6		h: 31.5	695			h: 28.0	920	

- Single pack: One compressor in a cardboard box. In some publications this packaging may be indicated as individual packaging. All single pack of 4 cylinder are shipped with a small 1/4 euro pallet (570 x 400 x 117 mm) under the individual box.
- Multipack: A full pallet of compressors, each individually packed in a cardboard box. Mainly dedicated to wholesalers and Danfoss distribution centres.
- Industrial pack: A full pallet of unpacked compressors. Mainly dedicated to OEM customers. In some publications this packaging may be indicated as 'Multiple packaging.'
- Nbr: Number of compressor in a pack

MT compressors in industrial pack - R22

Compressor model	Code no.				
	1	3	4	5	9
	208-230/1/60	200-230/3/60	460/3/60 400/3/50	230/1/50	380/3/60
MT018	MT18-1VM	MT18-3VM	MT18-4VM	MT18-5VM	-
MT022	MT22-1VM	MT22-3VM	MT22-4VM	MT22-5VM	MT22-9VM
MT028	MT28-1VM	MT28-3VM	MT28-4VM	MT28-5VM	MT28-9VM
MT032	MT32-1VM	MT32-3VM	MT32-4VM	MT32-5VM	MT32-9VM
MT036	MT36-1VM	MT36-3VM	MT36-4VM	MT36-5VM	MT36-9VM
MT040	MT40-1VM	MT40-3VM	MT40-4VM	-	-
MT044	MT44-1VM	MT44-3VM	MT44-4VM	-	MT44-9VM
MT050	MT50-1VM	MT50-3VM	MT50-4VM	-	MT50-9VM
MT056	MT56-1VM	MT56-3VM	MT56-4VM	-	MT56-9VM
MT064	MT64-1VM	MT64-3VM	MT64-4VM	-	MT64-9VM
MT072	-	MT72-3VM	MT72-4VM	-	MT72-9VM
MT080	-	MT80-3VM	MT80-4VM	-	MT80-9VM
MT100	-	MT100-3VM	MT100-4VM	-	MT100-9VM
MT125	-	MT125-3VM	MT125-4VM	-	MT125-9VM
MT144	-	MT144-3VM	MT144-4VM	-	MT144-9VM
MT160	-	MT160-3VM	MT160-4VM	-	MT160-9VM

VM = Compressor, threaded oil sight glass, 3/8" oil equalisation connection

MT compressors in single pack - R22

Compressor model	Code no.						
	1	3	4	5	6	7	9
	208-230/1/60	200-230/3/60	460/3/60 400/3/50	230/1/50	230/3/50	575/3/60 500/3/50	380/3/60
MT018	MT18-1VI	MT18-3VI	MT18-4VI	MT18-5VI	-	-	-
MT022	MT22-1VI	MT22-3VI	MT22-4VI	MT22-5VI	MT22-6VI	-	MT22-9VI
MT028	MT28-1VI	MT28-3VI	MT28-4VI	MT28-5VI	MT28-6VI	-	MT28-9VI
MT032	MT32-1VI	MT32-3VI	MT32-4VI	MT32-5VI	MT32-6VI	-	-
MT036	MT36-1VI	MT36-3VI	MT36-4VI	MT36-5VI	MT36-6VI	-	MT36-9VI
MT040	MT40-1VI	MT40-3VI	MT40-4VI	-	MT40-6VI	-	-
MT044	-	MT44-3VI	MT44-4VI	-	-	-	MT44-9VI
MT050	MT50-1VI	MT50-3VI	MT50-4VI	-	MT50-6VI	-	MT50-9VI
MT056	MT56-1VI	MT56-3VI	MT56-4VI	-	MT56-6VI	MT56-7VI	MT56-9VI
MT064	MT64-1VI	MT64-3VI	MT64-4VI	-	MT64-6VI	-	MT64-9VI
MT072	-	MT72-3VI	MT72-4VI	-	-	-	MT72-9VI
MT080	-	MT80-3VI	MT80-4VI	-	MT80-6VI	-	MT80-9VI
MT100	-	MT100-3VI	MT100-4VI	-	MT100-6VI	MT100-7VI	MT100-9VI
MT125	-	MT125-3VI	MT125-4VI	-	MT125-6VI	MT125-7VI	MT125-9VI
MT144	-	MT144-3VI	MT144-4VI	-	-	MT144-7VI	MT144-9VI
MT160	-	MT160-3VI	MT160-4VI	-	MT160-6VI	MT160-7VI	MT160-9VI

VI = Single compressor, threaded oil sight glass, 3/8" oil equalisation connection

MTZ compressors in industrial pack

R404A / R507A / R134a / R407A / C / F / R448A / R449A / R452A / R454A/C** / R455A* / R513A

Compressor model	Code no.				
	1	3	4	5	9
	208-230/1/60	200-230/3/60	460/3/60 400/3/50	230/1/50	380/3/60
MTZ018	MTZ18-1VM**	MTZ18-3VM**	MTZ18-4VM**	MTZ18-5VM*	-
MTZ022	MTZ22-1VM**	MTZ22-3VM**	MTZ22-4VM**	MTZ22-5VM*	MTZ22-9VM
MTZ028	MTZ28-1VM**	MTZ28-3VM**	MTZ28-4VM**	MTZ28-5VM*	MTZ28-9VM
MTZ032	MTZ32-1VM**	MTZ32-3VM**	MTZ32-4VM**	MTZ32-5VM*	MTZ32-9VM
MTZ036	MTZ36-1VM**	MTZ36-3VM**	MTZ36-4VM**	MTZ36-5VM*	MTZ36-9VM
MTZ040	MTZ40-1VM**	MTZ40-3VM**	MTZ40-4VM**	-	-
MTZ044	MTZ44-1VM**	MTZ44-3VM**	MTZ44-4VM**	-	MTZ44-9VM
MTZ050	MTZ50-1VM**	MTZ50-3VM**	MTZ50-4VM**	-	MTZ50-9VM
MTZ056	MTZ56-1VM**	MTZ56-3VM**	MTZ56-4VM**	-	MTZ56-9VM
MTZ064	MTZ64-1VM**	MTZ64-3VM**	MTZ64-4VM**	-	MTZ64-9VM
MTZ072	-	MTZ72-3VM**	MTZ72-4VM**	-	MTZ72-9VM
MTZ080	-	MTZ80-3VM**	MTZ80-4VM**	-	MTZ80-9VM
MTZ100	-	MTZ100-3VM	MTZ100-4VM	-	MTZ100-9VM
MTZ125	-	MTZ125-3VM	MTZ125-4VM	-	MTZ125-9VM
MTZ144	-	MTZ144-3VM	MTZ144-4VM	-	MTZ144-9VM
MTZ160	-	MTZ160-3VM	MTZ160-4VM	-	MTZ160-9VM

VM = Compressor, threaded oil sight glass, 3/8" oil equalisation connection

* Qualified with R454C / R455A.

** Qualified with R454A / R454C / R455A

MTZ compressors in single pack
R404A/R507A / R134a / R407A/C/F / R448A/R449A / R452A / R454A/C / R455A* / R513A**

Compressor model	Code no.						
	1	3	4	5	6	7	9
	208-230/1/60	200-230/3/60	460/3/60 400/3/50	230/1/50	230/3/50	575/3/60 500/3/50	380/3/60
MTZ018	MTZ18-1VI**	MTZ18-3VI**	MTZ18-4VI**	MTZ18-5VI*	-	-	-
MTZ022	MTZ22-1VI**	MTZ22-3VI**	MTZ22-4VI**	MTZ22-5VI*	MTZ22-6VI	-	MTZ22-9VI
MTZ028	MTZ28-1VI**	MTZ28-3VI**	MTZ28-4VI**	MTZ28-5VI*	MTZ28-6VI	-	MTZ28-9VI
MTZ032	MTZ32-1VI**	MTZ32-3VI**	MTZ32-4VI**	MTZ32-5VI*	MTZ32-6VI	MTZ32-7VI	MTZ32-9VI
MTZ036	MTZ36-1VI**	MTZ36-3VI**	MTZ36-4VI**	MTZ36-5VI*	MTZ36-6VI	MTZ36-7VI	MTZ36-9VI
MTZ040	MTZ40-1VI**	MTZ40-3VI**	MTZ40-4VI**	-	MTZ40-6VI	-	-
MTZ044	MTZ44-1VI**	MTZ44-3VI**	MTZ44-4VI**	-	MTZ44-6VI	MTZ44-7VI	MTZ44-9VI
MTZ050	MTZ50-1VI**	MTZ50-3VI**	MTZ50-4VI**	-	MTZ50-6VI	MTZ50-7VI	MTZ50-9VI
MTZ056	MTZ56-1VI**	MTZ56-3VI**	MTZ56-4VI**	-	MTZ56-6VI	MTZ56-7VI	MTZ56-9VI
MTZ064	MTZ64-1VI**	MTZ64-3VI**	MTZ64-4VI**	-	MTZ64-6VI	-	MTZ64-9VI
MTZ072	-	MTZ72-3VI**	MTZ72-4VI**	-	MTZ72-6VI	-	MTZ72-9VI
MTZ080	-	MTZ80-3VI**	MTZ80-4VI**	-	MTZ80-6VI	-	MTZ80-9VI
MTZ100	-	MTZ100-3VI	MTZ100-4VI	-	MTZ100-6VI	MTZ100-7VI	MTZ100-9VI
MTZ125	-	MTZ125-3VI	MTZ125-4VI	-	MTZ125-6VI	MTZ125-7VI	MTZ125-9VI
MTZ144	-	MTZ144-3VI	MTZ144-4VI	-	-	MTZ144-7VI	MTZ144-9VI
MTZ160	-	MTZ160-3VI	MTZ160-4VI	-	MTZ160-6VI	MTZ160-7VI	MTZ160-9VI

VI = Single compressor, threaded oil sight glass, 3/8" oil equalisation connection

* Qualified with R454C / R455A.

** Qualified with R454A / R454C / R455A.

Current version updates

- Added R454A / R454C / R455A
- Page 7: Corrected Internal free volume
- Page 25: Updated Three phase electrical characteristics
- Page 26: Updated Soft starters
- Page 29: Added Information about flammable logo
- Page 31: Updated Operating pressures
- Page 34: Updated sound values
- Page 35: Updated Recommended torque values

Previous version updates

- Added R448A / R449A / R452A
- Page 6: Updated compressor model designation
- Page 7: Updated technical specifications
- Page 19: Updated phase shift
- Page 25: Updated three phase electrical characteristics
- Page 26: Updated soft starters & voltage application usage
- Page 34: Updated sound values
- Page 31: Compressor mounting
- Page 38: Updated 4 cylinders packaging

Danfoss Cooling

is a worldwide manufacturer of compressors and condensing units for refrigeration and HVAC applications. With a wide range of high quality and innovative products we help your company to find the best possible energy efficient solution that respects the environment and reduces total life cycle costs.

We have 40 years of experience within the development of hermetic compressors which has brought us amongst the global leaders in our business, and positioned us as distinct variable speed technology specialists. Today we operate from engineering and manufacturing facilities spanning across three continents.



Danfoss Scrolls



Danfoss Inverter Scrolls



Danfoss Turbocor Compressors



Danfoss Light Commercial Refrigeration Compressors



Danfoss Maneurop Reciprocating Compressors



Danfoss Optyma™ Condensing Units

Our products can be found in a variety of applications such as rooftops, chillers, residential air conditioners, heatpumps, coldrooms, supermarkets, milk tank cooling and industrial cooling processes.

member of:



Danfoss A/S
Climate Solutions • danfoss.com • +45 7488 2222

Any information, including, but not limited to information on selection of product, its application or use, product design, weight, dimensions, capacity or any other technical data in product manuals, catalogues descriptions, advertisements, etc. and whether made available in writing, orally, electronically, online or via download, shall be considered informative, and is only binding if and to the extent, explicit reference is made in a quotation or order confirmation. Danfoss cannot accept any responsibility for possible errors in catalogues, brochures, videos and other material. Danfoss reserves the right to alter its products without notice. This also applies to products ordered but not delivered provided that such alterations can be made without changes to form, fit or function of the product. All trademarks in this material are property of Danfoss A/S or Danfoss group companies. Danfoss and the Danfoss logo are trademarks of Danfoss A/S. All rights reserved.