



130R1294

VLT® AutomationDrive FC 360

90–315 kW, Enclosure Sizes J8–J9

1 Introduction

This operating guide provides necessary information for qualified personnel to install and commission the AC drive. Read and follow the instructions to use the drive safely and professionally.

Do not dispose of equipment containing electrical components together with domestic waste. Collect it separately in accordance with local and currently valid legislation.

2 Safety

Pay particular attention to the safety instructions and general warnings to avoid the risk of death, serious injury, and equipment or property damage.

⚠ WARNING ⚠

HIGH VOLTAGE

AC drives contain high voltage when connected to AC mains input.

UNINTENDED START

The motor may start from control panel, I/O inputs, or fieldbus at any time, when the drive is connected to the AC mains.

DISCHARGE TIME

The drive contains DC-link capacitors, which can remain charged even when the drive is not powered. High voltage can be present even when the warning indicator lights are off.

- Stop the motor, and disconnect AC mains, permanent magnet type motors.
- Wait for the capacitors to discharge fully and measure it before performing any service or repair work.
- The minimum waiting time is 20 minutes.

LEAKAGE CURRENT

Leakage currents of the drive exceed 3.5 mA. Make sure that the minimum size of the ground conductor complies with the local safety regulations for high touch current equipment.

3 Installation

3.1 Mechanical Dimensions

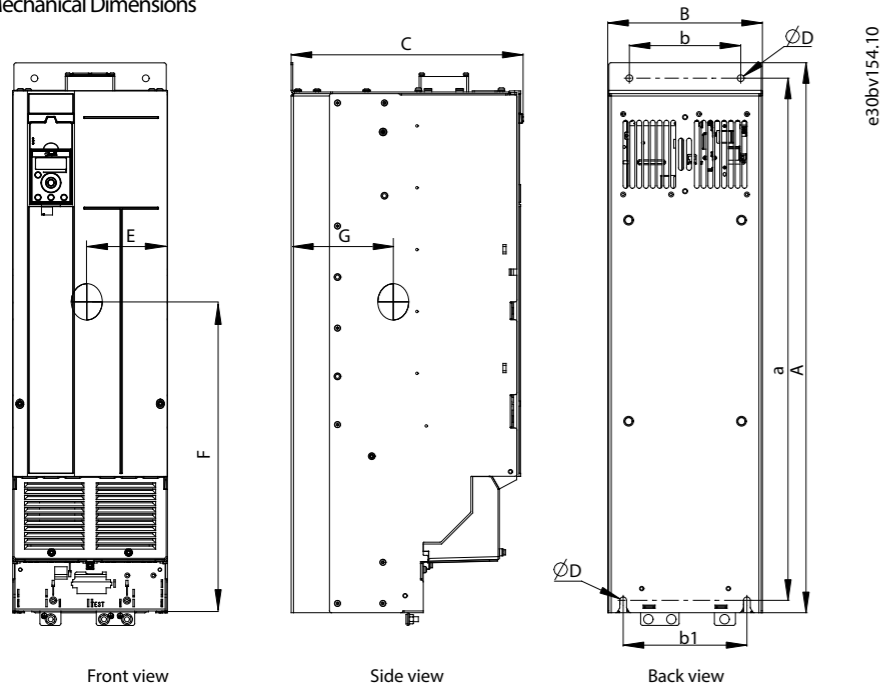

Illustration 1: Mechanical Dimensions, Enclosure Sizes J8–J9

Table 1: Power Ratings, Dimensions, and Weights for Enclosure Sizes J8–J9

Enclosure size (IP20)	Power [kW (hp)]	Height [mm (in)]			Width [mm (in)]		
		A	A ⁽¹⁾	a	B	b	b1
J8	110–160 (150–250)	889 (35.0)	909 (35.8)	844 (33.2)	250 (9.8)	180 (7.1)	200 (7.9)
J9	200–315 (300–450)	1096 (43.1)	1122 (44.2)	1051 (41.4)	350 (13.8)	280 (11.0)	271 (10.7)
Enclosure size (IP20)	Depth [mm (in)]	Mounting hole [mm (in)]	Center of gravity [mm (in)]			Maximum weight [kg (lb)]	
			C	D	E		F
J8	375 (14.8)	11 (0.4)	128 (5.0)	495 (19.5)	148 (5.8)	98 (216)	
J9	375 (14.8)	11 (0.4)	176 (6.9)	611 (24.1)	148 (5.8)	164 (362)	

Note: (1) Including decoupling plate.

3.2 Removing the Front Cover

Procedure:

- Step 1: Loosen and remove the 2 screws on the front cover.
- Step 2: Disconnect the front cover from the hooks.

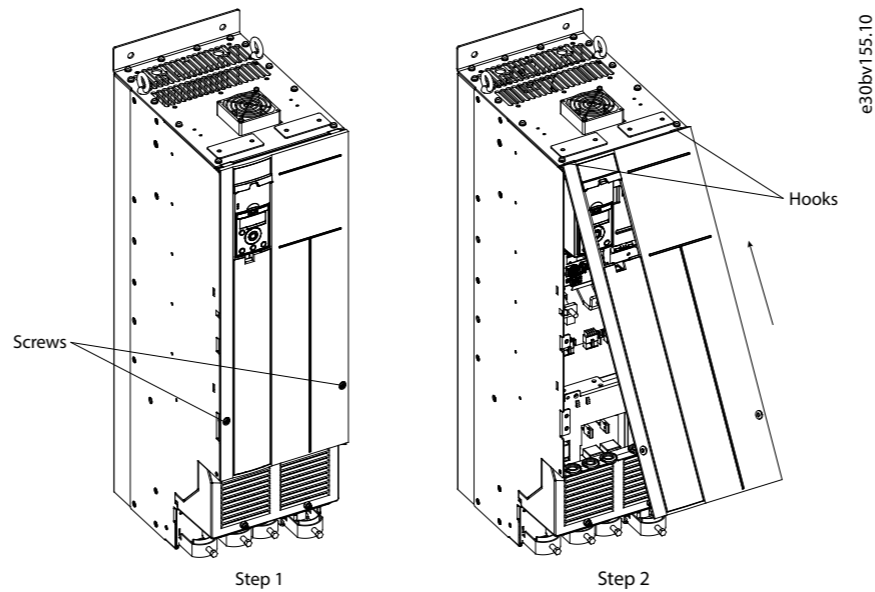

Illustration 2: Removing the Front Cover

3.3 Connecting to Mains, Motor, Control Terminals, and Relays

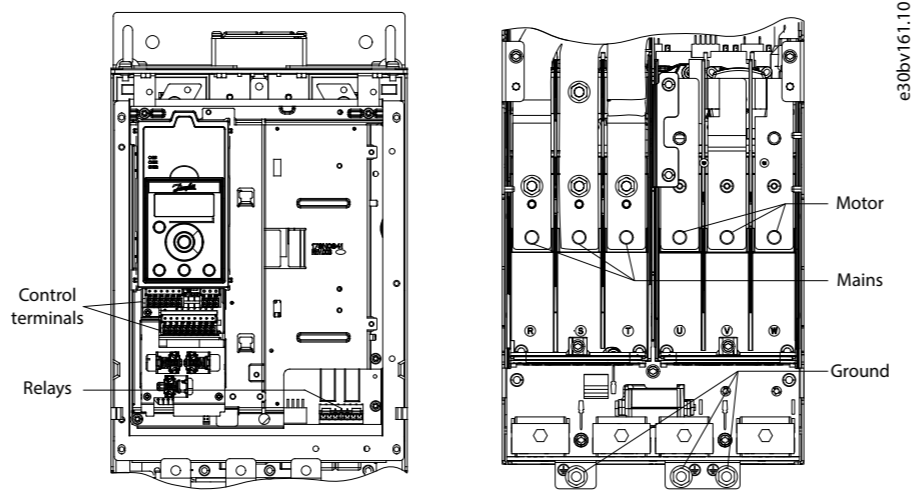

Illustration 3: Connecting to Mains, Motor, Control Terminals, and Relays

3.4 Control Terminals

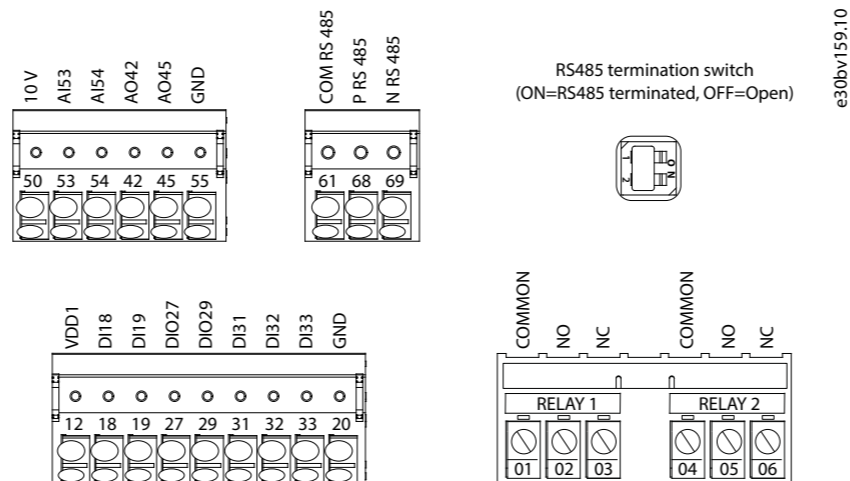

Illustration 4: Control Terminals

4 Specifications

Table 2: Electrical Data for Normal Overload, Mains Supply 3x380–480 V AC

Drive	Q110	Q132	Q160	Q200	Q250	Q315
Enclosure size	J8	J8	J8	J9	J9	J9
Normal overload=110% current during 60 s						
Typical shaft output at 400 V [kW]	110	132	160	200	250	315
Typical shaft output at 460 V [hp]	150	200	250	300	350	450
Output current (3-phase)						
Continuous (at 400 V) [A]	212	260	315	395	480	588
Intermittent (60 s overload) (at 400 V) [A]	233	286	347	435	528	647
Continuous (at 460 V) [A]	190	240	302	361	443	535
Intermittent (60 s overload) (at 460 V) [A]	209	264	332	397	487	589
Continuous kVA (at 400 V) [kVA]	147	180	218	274	333	407
Continuous kVA (at 460 V) [kVA]	151	191	241	288	353	426
Maximum input current						
Continuous (at 400 V) [A]	204	251	304	381	463	567
Continuous (at 460 V) [A]	183	231	291	348	427	516
Maximum number and size of cables per phase						
Mains and motor [mm ² (AWG)]	2x95 (2x3/0)			2x185 (2x350 mcm)		
Maximum external mains fuses [A]	315	350	400	550	630	800
Estimated power loss at 400 V [W]	2559	2954	3770	4116	5137	6674
Estimated power loss at 460 V [W]	2261	2724	3628	3569	4566	5714
Efficiency [%]	98					
Output frequency [Hz]	0–590					
Heat sink overtemperature trip [°C (°F)]	110 (230)					
Control card overtemperature trip [°C (°F)]	75 (167)			80 (176)		

Table 3: Electrical Data for High Overload, Mains Supply 3x380–480 V AC

Drive	H90K	H110	H132	H160	H200	H250
Enclosure size	J8	J8	J8	J9	J9	J9
High overload=150% current during 60 s						
Typical shaft output at 400 V [kW]	90	110	132	160	200	250
Typical shaft output at 460 V [hp]	125	150	200	250	300	350
Output current (3-phase)						
Continuous (at 400 V) [A]	177	212	260	315	395	480
Intermittent (60 s overload) (at 400 V) [A]	266	318	390	473	593	720
Continuous (at 460 V) [A]	160	190	240	302	361	443
Intermittent (60 s overload) (at 460 V) [A]	240	285	360	453	542	665
Continuous kVA (at 400 V) [kVA]	123	147	180	218	274	333
Continuous kVA (at 460 V) [kVA]	127	151	191	241	288	353
Maximum input current						
Continuous (at 400 V) [A]	171	204	251	304	381	463
Continuous (at 460 V) [A]	154	183	231	291	348	427
Maximum number and size of cables per phase						
Mains and motor [mm ² (AWG)]	2x95 (2x3/0)			2x185 (2x350 mcm)		
Maximum external mains fuses [A]	315	350	400	550	630	800
Estimated power loss at 400 V [W]	2031	2289	2923	3093	4039	5004
Estimated power loss at 460 V [W]	1828	2051	2089	2872	3575	4458
Efficiency [%]	98					
Output frequency [Hz]	0–590					
Heat sink overtemperature trip [°C (°F)]	110 (230)					
Control card overtemperature trip [°C (°F)]	75 (167)			80 (176)		

5 Ambient Conditions

J8–J9 enclosure size	IP20/Chassis
Vibration test (standard)	0.7 g
Relative humidity	5%–95% (IEC 721-3-3; Class 3K3 (non-condensing) during operation)
Aggressive environment (IEC 60068-2-43) H ₂ S test	Class Kd
Aggressive gases (IEC 60721-3-3)	Class 3C3
Test method according to IEC 60068-2-43	H ₂ S (10 days)

