

ENGINEERING
TOMORROW



May 2024 | Danfoss Climate Solutions for cooling

Cool

Update

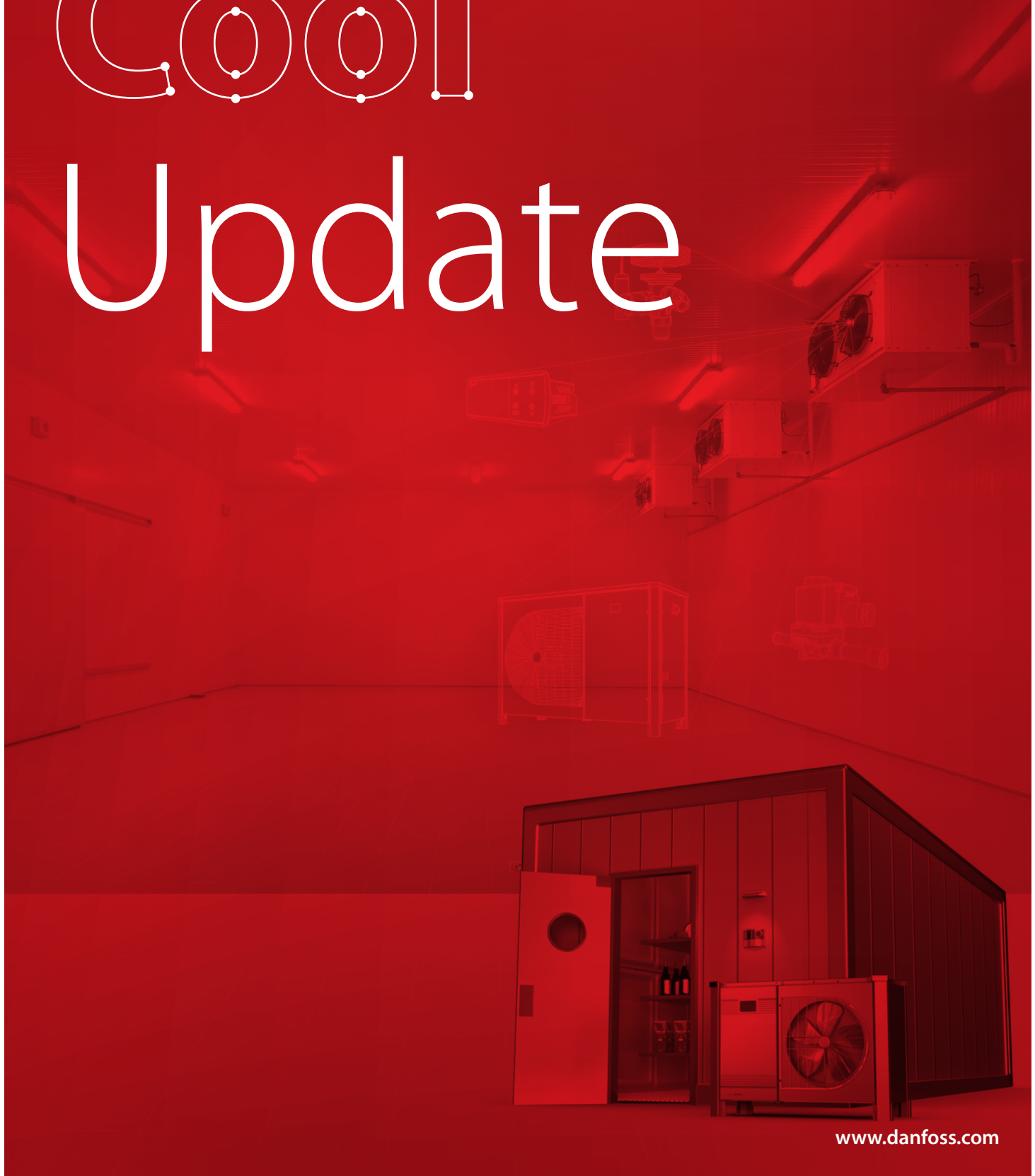

www.danfoss.com

Introduction

Danfoss Cool Update keeps you updated with the latest news on the cooling and industrial products portfolios from Danfoss Climate Solutions. The content is intended to give a quick overview of core technical news and updates in our product portfolio, including links to relevant documentation and more information.

Danfoss Cool Update is sent out, on a monthly basis, to ensure you are always up to date with the latest innovations and changes made to Danfoss products and solutions.

We hope you will enjoy reading Danfoss Cool Update!

Table of Contents

Launching Semi-Hermetic Filter Drier for CO ₂ Applications	3
KoolProg Ver 5.1.x: Maintenance Release Update.....	3
MMIGRS2 and MCX15/20B2: New BIOS Release	4
Extend STF Coil Production to Grodzisk Plant, Poland	6
Videos	7

Launching Semi-Hermetic Filter Drier for CO₂ Applications

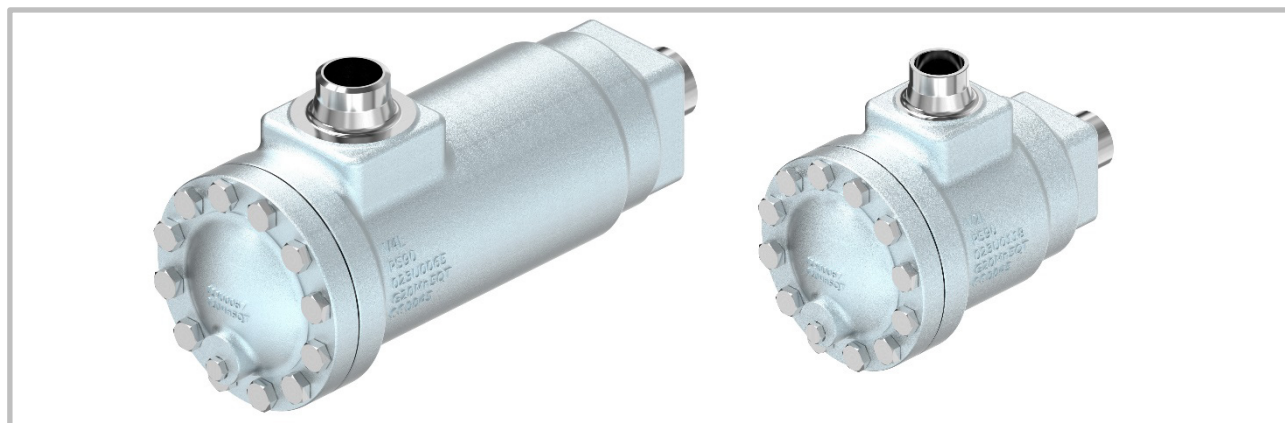

We are pleased to announce that Danfoss is launching DCR semi-hermetic filter driers for the CO₂ applications. These new driers are designed for 90 bar working pressure and -55 to 100°C operating temperature, suitable for sub-critical and trans-critical refrigeration systems.

DCR filter driers for CO₂ have lesser weight and unique cartridge design to facilitate ease of handling and service. The casting body eliminates welding and offers high reliability. The optimized core plate inlet and outlet design contributes higher flow capacity. This new series comes with single (DCR48) and dual core (DCR96) housings with steel connectors for solder and butt weld options. The existing DCR inserts 48DM, 48DC, and 48 fit seamlessly into the new DCR CO₂ Housings.

Starting in week 14, 2024, Danfoss India will manufacture the new DCR CO₂ driers and supply globally. The new code numbers are already released, and more information is available in the datasheet.

See the new products here: [R744 | Danfoss Global Product Store](#)

KoolProg Ver 5.1.x: Maintenance Release Update

A new version of KoolProg (Ver. 5.1) is now available for download and we have made several improvements and enhancements to it. It includes auto software update for future releases (Ver 5.2 onwards). EKE 100 1V & 2V, EKF 1A & 2A versions are supported with an upgraded firmware.

Detailed description

1. Supports EKE100 1V and 2V Super Heat Controllers with latest SW versions

Product Description	Part Code	Software Version
EKE 100 1V IP00	080G5050	2.00
EKE 100 1V IP20	080G5051	2.00
EKE 100 IP20 with display	080G5052	2.00
EKE 100 2V IP00	080G5055	2.00
EKE 100 2V IP20	080G5056	2.00
EKE100 2V IP20 with display	080G5057	2.00

- Supports firmware flashing of EKE 100 controllers through KK 2.0, Adam and ICP Con gateways.
- Implemented the Quick Wizard window for the EKE 100 controllers.
- Increases the data log points from 10 to 20 parameters to plot the graph for EKE 100 controllers only.
- A new pop up has been added that lets the customer know to switch off the main switch while programming it from Project window (using export button) and copy to controller window.

2. Supports new PV version for EETa 3W controller

- Supports new PV version PV03 for EETa 3W controller variant with code number 080N0015 and firmware version 1.51.

3. Implemented “comparison setting” feature

- Comparison setting feature enables the user to compare the controller settings with offline project/parameter file.
- Also, it is possible to compare connected controller settings with its default values and generate report.
- This feature is available for all controllers except ETC1H series, which is getting phased out.



4. Implemented KoolProg Software auto update feature

- Whenever a new version of KoolProg is released into the market, user shall receive a pop-up message to update the KoolProg to its latest version. This applies for future releases (5.2 onwards)

5. Supports new software version for all EKE1x variants

- Supports new software version 2.07 with PV version PV05 for EKE 1A, EKE 1B, EKE 1C and EKE 1D controllers.

Download latest version here: [KoolProg software](#)

MMIGRS2 and MCX15/20B2: New BIOS Release

We would like to inform you that, the BIOS version of MMIGRS2 and MCX15/20B2 products have been updated for the following reasons.

MMIGRS2

Problem solved:

- The displays may show some random horizontal lines which appear and disappear quickly. The lines can be attenuated or made invisible by adjusting manually the LCD contrast. The functionality of the display is not impacted.

Further minor change:

- Removed RS232 selection from “COM SELECTION” menu

New functionality:

- MMIGRS2 is now compatible with Alsmart controllers, the new Danfoss programmable controller platform.

On the MMIGRS2 label the product version will be updated from PV04 to PV05 and SW version from SW1.17 to SW 1.21

Affected products

Product	Code	Description	OLD BIOS Ver.	NEW BIOS Ver.	End of Transition Period, from Old to New BIOS	OLD PV	NEW PV
MMIGRS2	080G0294	MMIGRS2 Panel S	1v17	1v21	June-24	PV04	PV05
	080G0295	MMIGRS2 Wall S	1v17	1v21	April-24	PV04	PV05
	080G0297	MMIGRS2 Panel I/27	1v17	1v21	April-24	PV04	PV05
	080G0298	MMIGRS2 C.C. Panel I/27	1v17	1v21	May-24	PV04	PV05
	080G0299	MMIGRS2 C.C. Wall S	1v17	1v21	April-24	PV04	PV05

MCX15B2, MCX20B2

Problem solved:

- Text in customer application that is too long causes unwanted carriage return and scrolling across screen. This can happen only on applications developed in C++ and since new LCD driver has been introduced in March 2022.

Further minor fix:

- Filesystem issue when uploading files from web interface and disk is full. The uploading was failing without returning an error message.

New functionalities:

- Added IP setting from USB.

The command syntax to be use in the mcx20b2.cmd file is:

SetNetworkIP = 192.168.1.2 where the desired IP address must be used.

- Improved generation of Self Signed Certificates

On the MCX15B2 and MCX20B2 label the product version will be updated from PV04 to PV05 and SW version from SW1.20 to SW 1.30

Affected products

Product	Code	Description	OLD BIOS Ver.	NEW BIOS Ver.	End of Transition Period, from Old to New BIOS	OLD PV	NEW PV
MCX15B2	080G0327	MCX15B2, RS485, S	1v20	1v30	End April-24	PV04	PV05
	080G0328	MCX15B2, LCD, RS485, S	1v20	1v30	End May-24	PV04	PV05
MCX20B2	080G0329	MCX20B2, 2xRS485, I	1v20	1v30	End April-24	PV04	PV05
	080G0330	MCX20B2, LCD, 2xRS485, S	1v20	1v30	August-24	PV04	PV05
	080G0331	MCX20B2, LCD, 2xRS485, I	1v20	1v30	August-24	PV04	PV05
	080G0332	MCX20B2, LCD, 4xSSR, 2xRS485, S	1v20	1v30	End April-24	PV04	PV05

The new BIOS Service Pack 24SP1 for MCX (Released Bios_24SP1.zip) will be available for download at [MCX controllers | MCX programmable controls | Danfoss](#).

The delivery in production of the new BIOS will start in April 2024, but the effective date depends on several factors like the amount of stock and the sales trend; it will be different for each part number, as stated in the tables above, and may change over time.

It is expected to have a transition period with a mix of versions on stocks.

Extend STF Coil Production to Grodzisk Plant, Poland

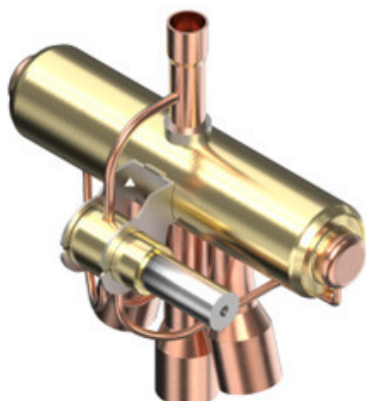

To support 4-way reverse valve STF business in Europe, Danfoss Saginomiya is extending the STF production to Grodzisk, Poland.

The project will be completed by different steps to cover STF coils and valves, detailed information will come with following communications when the timeline is finalized.

The Product Note covers the first step 'Extend STF Coil production to Grodzisk Plant'.

- The production extension will not impact product design, quality, production, certificates, assembly, packaging, or suppliers.
- The label will change to "Made in China, Assembled in Poland".
- New code numbers will be created, please refer to below cross-reference list.

Affected products

The below table shows the list of affected products.

The new codes are ready to order. Consider stock of previous codes, the transition period could be lasted to Q3.

During this period, customers may receive the mixed products with previous codes and new codes.

Cross-reference list

Model Name	New Code	Old Code	Drawing No.	Qty per Box
STF-01AB500A1	061L7000	061L2092	N-HV-13363-B	10
STF-01AB503B1	061L7068	061L2038	N-HV-13141-D	100
STF-01AD503B1	061L7002	061L2100	N-HV-13017-G	10
STF-01AE503B1	061L7003	061L2099	N-HV-13389-E	100
STF-01AJ1929A0	061L7006	061L2139	N-HV-13642-C	100
STF-01AJ504F1	061L7007	061L2125	N-HV-13090-E	48
STF-01AJ506B1	061L7008	061L2093	N-HV-13209-E	10
STF-01AJ512E1	061L7009	061L2074	N-HV-13273-C	60
STF-01AJ586A1	061L7010	061L2121	N-HV-13465-D	60
STF-H01AB2403A1	061L7013	061L2141	N-HV-83332-A	100
STF-H01AJ1709A1	061L7014	061L2219	N-HV-83065-A	100
STF-H01AJ1736D1	061L7015	N/A	N-HV-83346-B	100
STF-H01AJ1738A1	061L7016	061L2220	N-HV-83330-A	60
STF-H01AJ1738D1	061L7017	061L2142	N-HV-83421-A	60
STF-01AJ504F1	061L7100	061L2094	N-HV-13090-E	10
STF-01AJ512E1	061L7102	061L2095	N-HV-13775-C	10
STF-01AJ504F1	061L7101	061L2016	N-HV-13090-E	100

Videos

- Your step-by-step guide on setting up the ADAP-KOOL Wizard - [LINK](#)
- How to install the Danfoss GBCT ball valve - [LINK](#)
- Mechanical installation of the EKE 100 superheat controllers and valve drivers - [LINK](#)
- Electrical installation of the EKE 100 superheat controllers and valve drivers - [LINK](#)
- How to wire the EKE 100 superheat controllers and valve drivers - [LINK](#)



Danfoss Climate Solutions EER Region

– Bulgaria, Croatia, Czech Republic, Hungary, Poland, Romania, Serbia, Slovakia, Slovenia, Ukraine

Danfoss can accept no responsibility for possible errors in catalogues, brochures and other printed material. Danfoss reserves the right to alter its products without notice. This also applies to products already on order provided that such alterations can be made without subsequent changes being necessary in specifications already agreed. All trademarks in this material are property of the respective companies. Danfoss and all Danfoss logotypes are trademarks of Danfoss A/S. All rights reserved.