

Data sheet

Pressure transmitter SIL-2

DST P92S



The DST P92S OEM pressure transmitter is designed for use in Mobile and Industrial hydraulic applications.

The transmitter is suitable for use in a functional safety environment with a requirement of PLd, EN ISO 13849-1: 2015 or AgPLd EN ISO 25119: 2010 or SIL2, IEC 61508:2010, respectively.

Further Danfoss holds a third party approval from TÜV to ensure easy implementation into any safety system.

Features

- Designed for use in severe hydraulic applications
- For operating temperature up to 85 °C
- Pressure range 0-10 bar to 0-1200 bar
- Dual output signal: 4-20 / 20-4 mA or ratiometric 10-90 / 90-10%
- Cyclic diagnostic
- Start up diagnostic
- Wetted parts made of stainless steel
- Designed towards OEM requirements

Conformity

- PLd EN ISO 13849-1: 2015
- AgPLd EN ISO 25119:2010
- SIL2 IEC 61508: 2010
- CE marked
- ECE type approval

Note: In respect to Customer Change Notification, only changes in relation to Form Fit and Function can be informed upon!

Technical data

Accuracy (incl. non linearity, hysteresis and repeatability)	< 0.5% FS ¹⁾
Overall accuracy under reference conditions	+/- 1% FS [0 – 85 °C] +/- 1,5% FS [-25 – 0 °C] +/- 2,5% FS [-40 – -25 °C]
Long-run stability	<0,2% FS p.a.
Response time liquids (10 – 90%)	2 ms

¹⁾ 1, Load 100 Ω, temperature in steady state, accuracy valid for output 1 for 4 – 20 mA

Overload and burst pressure

Standard pressure [bar]	40	60	100	160	250	400	600
Overload pressure [bar]	80	120	200	320	500	800	1200
Burst pressure [bar]	400	600	1000	1600	2500	4000	>4000

Environmental conditions

Media temperature range	-40 – 125 °C	
Operating temperature range	-40 – 85 °C	
Storage temperature range	-40 – 100 °C	
Voltage supply	9 – 32 V DC, allowable ripple @50Hz: 10% (for current output) 5V ±10% (for ratiometric voltage output)	
Electrical Protection	Short circuit protected, signal on GND/VCC and reverse polarity protection	
Electric Magnetic Compatibility Directive [EMC]	2014/30/EU	
EMC	DIN EN 61326-1 DIN EN 61326-2-3 DIN EN 61326-3-1 E1 type approval: All vehicle types with a 12 V or 24 V - electrical wiring and battery (-) at the body	
Vibration stability	20 g	EN60068-2-6
Shock mechanical	500 g	EN60068-2-27
Enclosure	1.4301/ PBT-GF30	
Material with medium contact	1.4548/Viton	
Weight	50 g	
Enclosure	IP67	

Functional safety

Machinery Directive [MD]	2006/42/EC	
IEC 61508:2010	SIL 2	Safety related subsystem, type B
	1oo1 architecture	SFF 95.8% 4-20mA / 93,1% ratiometric (incl. control unit)
	HFT 0	PFH 6.1*10 ⁻⁹ (4-20 mA) / 4.9*10 ⁻⁹ (ratiometric)
EN ISO 13849-1:2015	PL d	CCF 70 points
	Category 2	MTTF _d high >100 years
	DC medium (incl. control unit)	
Safety function	Safety conversion of the measured pressure into two proportional opposing current signals. Refer also to the Safety guide.	

Ordering

Available code numbers

Type	Measuring range	Pressure connection	Electrical connection	Electrical output	Code no
DST P92S	0 – 40 bar	G1/4 DIN 3852-E	M12	4-20mA / 20-4mA	078G1000
DST P92S	0 – 60 bar	G1/4 DIN 3852-E	M12	4-20mA / 20-4mA	078G1001
DST P92S	0 – 100 bar	G1/4 DIN 3852-E	M12	4-20mA / 20-4mA	078G1002
DST P92S	0 – 160 bar	G1/4 DIN 3852-E	M12	4-20mA / 20-4mA	078G1003
DST P92S	0 – 250 bar	G1/4 DIN 3852-E	M12	4-20mA / 20-4mA	078G1004
DST P92S	0 – 400 bar	G1/4 DIN 3852-E	M12	4-20mA / 20-4mA	078G1005
DST P92S	0 – 600 bar	G1/4 DIN 3852-E	M12	4-20mA / 20-4mA	078G1006

For other requests please see below and/or contact Danfoss.

Dimensions

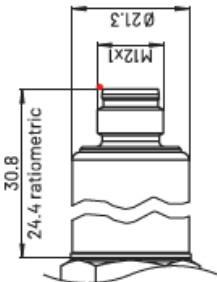
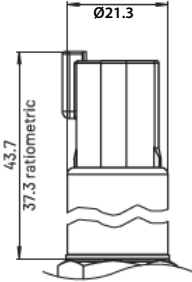
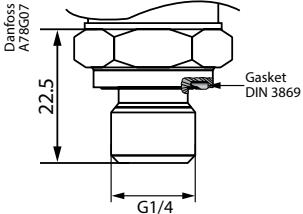
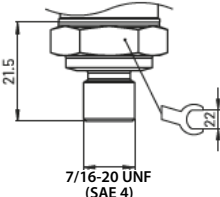
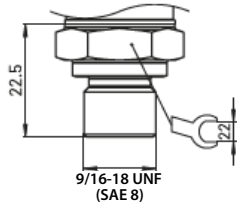
	M12x1, 5-pole PBT	DT04-4p, 4-pole PBT	
Electrical connection			
Pressure connection	G $\frac{1}{4}$ DIN3852-E Viton gasket	7/16 - 20 UNF	9/16 - 18 UNF
			
Recommended torque	Max. 35 Nm		

Electrical connections

	M12x1, 5-pole PBT	DT04-4p, 4-pole PBT
Pin Configurations		
Enclosure (IP protection fulfilled together with mating connector)	IP67	IP67
Material	PBT	PBT
Electrical connections 4 - 20 mA/20 - 4 mA (3 wire)	Pin 1: VCC Pin 2: Output 2 [20 – 4 mA] Pin 3: GND Pin 4: Output 1 [4 – 20 mA] Pin 5: Do not connect	Pin 1: VCC Pin 2: GND Pin 3: Output 2 [20 – 4 mA] Pin 4: Output 1 [4 – 20 mA]
Electrical connections 10-90 / 90-10% ratiometric	Pin 1: VCC Pin 2: Output 2 [90 – 10%] Pin 3: GND Pin 4: Output 1 [10 – 90%] Pin 5: Do not connect	Pin 1: VCC Pin 2: GND Pin 3: Output 2 [90 – 10% VCC] Pin 4: Output 1 [10 – 90% VCC]

Recommended terminal layout

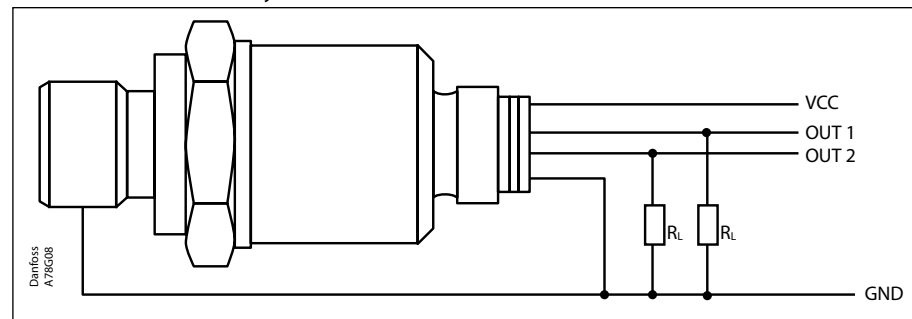

For detailed load reference please refer to the Safety guide.