

Vickers by Danfoss

Check Valves



Pilot Operated Check Valves

PCGV-6/8, 10 Series; PCG5V-6/8, 20 Series

Typical Section

Typical PCG5V model with internally drained pilot piston

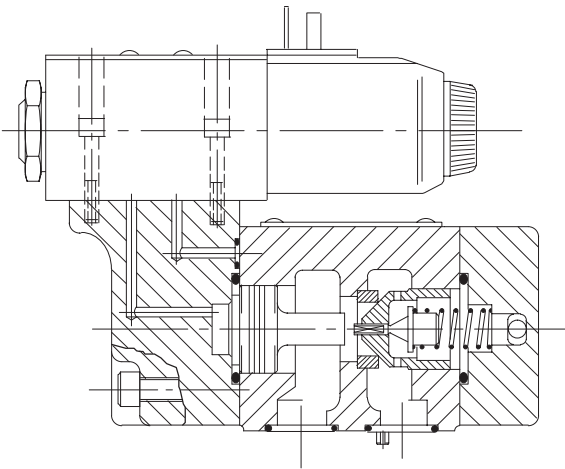

Basic Characteristics

Max. operating pressure 350 bar
(5000 psi)

Max. flow rates:

PCG(5)V-6 150 L/min (40 USgpm)

PCG(5)V-8 300 L/min (80 USgpm)

Mounting surfaces to ISO 5781:

PCG(5)V-6 AG-06-2-A

PCG(5)V-8 AH-08-2-A

General Description

These pilot operated check valves operate as a direct check valve but can also be opened by pilot pressure, on the control piston, to permit free reverse flow. The amount of pilot pressure required to open the valve is stated as a ratio of the pressure above the check to the pilot pressure.

Two basic types of valve are available relative to the piloting method. The PCGV model is the traditional type requiring an external remote pilot valve to control the admission and release of pressure to the pilot piston. The other, the PCG5V model, has a fitted solenoid-operated pilot valve that obviates a separate mounting and can include manual override(s) for local emergency control. The PCG5V type can take its hydraulic pilot supply from the load pressure in the adjacent cylinder under control or from a remote source. Where cylinder pressure is to be used and where even the minimal

internal leakage through the closed pilot valve would cause an unacceptable amount of cylinder "creep", a Vickers poppet-type pilot valve can be substituted. This pilot would be a model DG3VP-3-103A (see catalog 642); ask your Vickers representative for advice.

All PCG(5)V valves are available with or without an integral decompression feature.

Features and Benefits

- Less power wastage from low pressure drops.
- Smooth steady lowering of heavy weights in conjunction with flow control valves aided by use of externally drained models.
- Zero-leakage design to prevent actuator "creep" from check valve leakage.
- Smooth release of stored energy by using models with decompression poppets.
- Extra-fast response from solenoid piloted models using actuator-supplied pilot pressure instead of remote external source.
- International standard mountings permit fitment on many existing installations.
- Reduced installed cost and space results from higher power/weight ratios.

Operation of both types of valve is portrayed in the "Functional Symbols" section, whilst the following sectional illustration shows the construction of the solenoid controlled type. The remote piloted type operates and can be used in the same ways as the previous 4CG models described in the Vickers "Industrial Hydraulics Manual". The solenoid pilot directional control valve option is basically the same as the single solenoid directional valve shown in the same manual.

Functional Symbols

Examples:

Pilot operated check valve with internally drained pilot piston, PCGV-**(D)-10 model

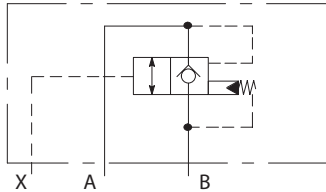

Pilot operated check valve with externally drained pilot piston, PCGV-**(D)- 1-10 model

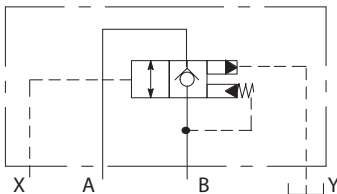

Solenoid controlled pilot operated check valve with internally drained pilot piston, PCG5V -**(D), 11 and 20 series

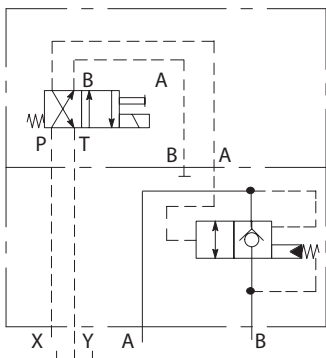

Solenoid controlled pilot operated check valve with externally drained pilot piston, PCG5V-**(D)- 1, 11 and 20 series

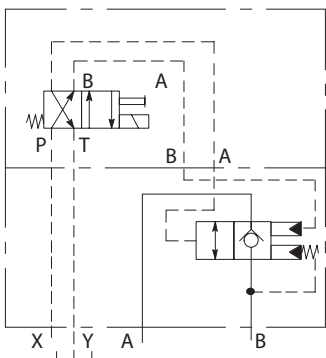

Model Code

Features in brackets () may be omitted if not required. All other features must be specified.

Basic Models (Without Integral Solenoid Pilot Valve)

(F3-) PCGV- * * (D) (-1)-1*

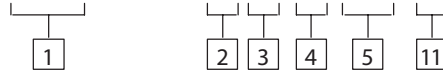

Models With Integral Solenoid Pilot Valve

(F3-) PCG5V - * - * (D) (-1) -E- * -(V) M- * (L)- * 5-2***

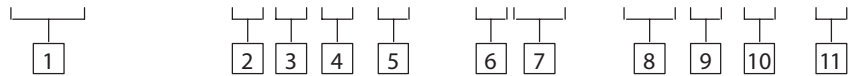

1 Fluid compatibility

Blank = Antiwear hydraulic oil (class L-HM), invert emulsion (class L-HFB) or water glycol (class L-HFC)

F3 = As above or phosphate ester (class L-HFD)

2 Mounting surface ISO 5781

6 = Code AG-06-2-A

8 = Code AH-08-2-A

3 Cracking pressure

A = 2 bar (29 psi)

C = 5 bar (73 psi)

F = 10 bar (145 psi)

4 Decompression feature

Omit if not required

5 External drain option

1 = Externally drained pilot piston

Omit for internally drained pilot piston

6 Manual override options

Override option in solenoid end only.

Blank = Plain manual override

H = Water-resistant override, DC solenoid only

Z = No override

7 Solenoid identity method

V = Solenoid "A" at port A end of pilot valve; solenoid "B" at B end of pilot valve (German practice).

Omit for solenoid identity to USA ANSI B93.9 standard, i.e. energize solenoid "A" for P to A; solenoid "B" for P to B.

8 Solenoid connection type ▲

U = ISO 4400 (DIN 43650) on coil ◆

FW = 1/2" NPT thread conduit box

FTW = 1/2" NPT thread conduit box and terminal strip

FJ = M20 thread conduit box

FTJ = M20 thread conduit box and terminal strip

▲ Other connection types as shown in catalog 2015 (DG4V-3/3S) may be made available depending on quantities.

◆ Female connector to be supplied by user.

9 Indicator lights

Option for solenoid connection types F(T)W and F(T)J

L = Lights fitted

Omit if lights not required

For U type coil, use plug with integral light, see 7 pages on.

10 Coil rating

A = 110V AC

B ■ = 110V AC 50 Hz/120V AC 60 Hz

C = 220V AC 50 Hz

D ■ = 220V AC 50 Hz/240V AC 60 Hz

G = 12V DC

H = 24V DC

■ For 60 Hz or dual frequency.

11 Design number

10 series for PCGV models

20 series for PCG5V models

Subject to change. Installation

dimensions unaltered for design

numbers 10-19 and 20-29 respectively.

Operating Data

Typical with petroleum oil at 21 cSt (102 SUS) and at 50 °C (122 °F).

Maximum pressures: Ports A, B and X Port Y ▲: PCGV, 10 series PCG5V, 20 series ▲ Normally drained directly to the reservoir. For fast closure of valves under low load pressure conditions use the external drain option ("1" at model code 5). For PCGV models apply pressure to port Y to retract the pilot piston.	350 bar (5000 psi) 350 bar (5000 psi) 100 bar (1500 psi) PCG5V, 20 series valves are designed to satisfy the needs of most applications. Consult your Vickers representative about an alternative model if: a) Valves are required to remain pressurized for long periods without frequent switching, and/or b) Back pressure on port Y is required to rise above 100 bar (1500 psi)
Maximum flow rates: PCG(5)V-6 PCG(5)V-8	150 L/min (40 USgpm) 300 L/min (80 USgpm)
Cracking pressures	See "Model Code " 3
Pilot piston area ratios Without decompression feature: All models With decompression feature ("D" at model code 4): PCG(5)V-6 models PCG(5)V-8 models	3,5:1 33,8:1 52,6:1
Pilot pressure	See page 5
Pressure drops	See next page

Electrical Data for PCG5V Models

Coil voltages	See "Model Code " 10
Permissible voltage fluctuation: Maximum Minimum	See "Temperature Limits ", page 5 90% of rated voltage, see "Model Code " 10
Relative duty factor	Continuous, ED = 100%
Types of protection: ISO 4400 coils with plug fitted correctly Conduit box Coil winding Lead wires (coils type F**) Coil encapsulation	IEC144, class IP65 IEC144, class IP65 Class H Class H Class F
Power consumption for coils listed in "Model Code " 10	Initial ◆ Holding VA (rms) VA (rms)
AC coils: Types A, C at 50 Hz Types B, D at 50 Hz Types B, D at 60 Hz	225 39 265 49 260 48
DC coils: G H	30W – 30W –
	◆ 1st half cycle; solenoid armature fully retracted.

Performance Characteristics

Typical with petroleum oil at
21 cSt (102 SUS) and at 50°C (122 °F)
unless stated otherwise.

Pressure Drops

PCG(5)V-6 models

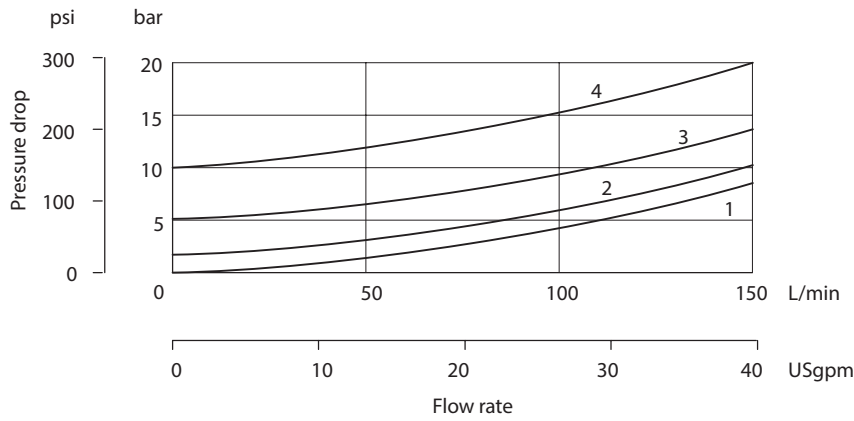

PCG(5)V-8 models

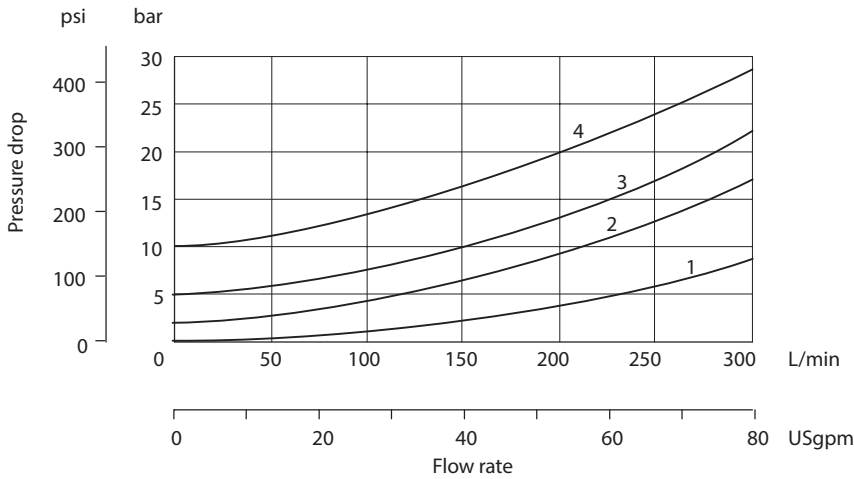

Port B to A, piloted open Curve 1
 Port A to B, no pilot pressure:
 PCG(5)V-*A models Curve 2
 PCG(5)V-*C models Curve 3
 PCG(5)V-*F models Curve 4

Pilot Pressure

The pilot pressure required to open the check valve or decompression poppet is stated as a ratio of the pressure on the check (port B) to the pilot pressure. To determine the required pilot pressure the following formulae should be used. These are valid for pressures calculated in either bar or psi, using the appropriate "C" factor.

For internally drained pilot piston models, 5

$$\text{Pilot pressure } P_X = \frac{P_B - P_A}{\text{Area ratio}} + P_A + C$$

For externally drained pilot piston models, "1" at model code 5:

$$\text{Pilot pressure } P_X = \frac{P_B}{\text{Area ratio}} + 0,85 P_Y + C$$

Where:

P_X = Pressure at pilot port X

P_B = Pressure at free flow outlet port B

P_A = Pressure at free flow inlet port A

P_Y = Back pressure at drain port Y

C = Varies according to cracking pressure, see table.

Model type	"C" factor bar	psi
PCG(5)V-6A	0,6	9
PCG(5)V-6C	1,5	22
PCG(5)V-6F	4,0	58
PCG(5)V-8A	0,6	9
PCG(5)V-8C	1,5	22
PCG(5)V-8F	3,0	44

Hydraulic Fluids

All valves can be used with:

Antiwear hydraulic oils (class L-HM)

Invert emulsions (class L-HFB)

Water glycol (class L-HFC)

Phosphate ester (class L-HFD), adding "F3-" prefix at model code 1.

The extreme viscosity range is from 500 to 13 cSt (2270 to 70 SUS) but the recommended range is 54 to 13 cSt (245 to 70 SUS).

For further information about fluids see catalog 920.

Temperature Limits

Minimum ambient: -20°C (-4°F)

Maximum ambient:

For PCGV valves: 70°C (158°F)

For PCG5V valves with coils listed in model code 10 and at 110% of rated voltage:

Coil type and frequency	Max. ambient temperature
Dual frequency coils	
at 50 Hz	65°C (149°F)
at 60 Hz	65°C (149°F)
Single frequency coils	
at 50 Hz	65°C (149°F)
DC coils	70°C (158°F)

Fluid temperatures (all models)

	Petroleum oil	Water-containing
Min.	-20°C (-4°F)	$+10^{\circ}\text{C}$ ($+50^{\circ}\text{F}$)
Max.*	$+70^{\circ}\text{C}$ ($+158^{\circ}\text{F}$)	$+54^{\circ}\text{C}$ ($+129^{\circ}\text{F}$)

* To obtain optimum service life from both fluid and hydraulic system, 65°C (150°F) normally is the maximum temperature except for water-containing fluids.

For synthetic fluids consult fluid manufacturer or Vickers representative where limits are outside those of petroleum oil.

Whatever the actual temperature range, ensure that viscosities stay within the limits specified in the "Hydraulic Fluids" section.

Contamination Control Requirements

Recommendations on contamination control methods and the selection of products to control fluid condition are included in Vickers publication 9132 or 561, "Vickers Guide to Systemic Contamination Control". The book also includes information on the Vickers concept of "ProActive Maintenance". The following recommendations are based on ISO cleanliness levels at $2\ \mu\text{m}$, $5\ \mu\text{m}$ and $15\ \mu\text{m}$. For products in this catalog the recommended levels are:

Up to 210 bar (3050 psi) 20/ **18/15**
Above 210 bar (3050 psi) 20/ **18/15**

Installation Dimensions in mm (inches)

PCGV Model

3rd angle projection 

PCGV-**(D)-1 models only:
Alternative drain port G 1/4 (1/4" BSPF).
Remove plug to make connection.

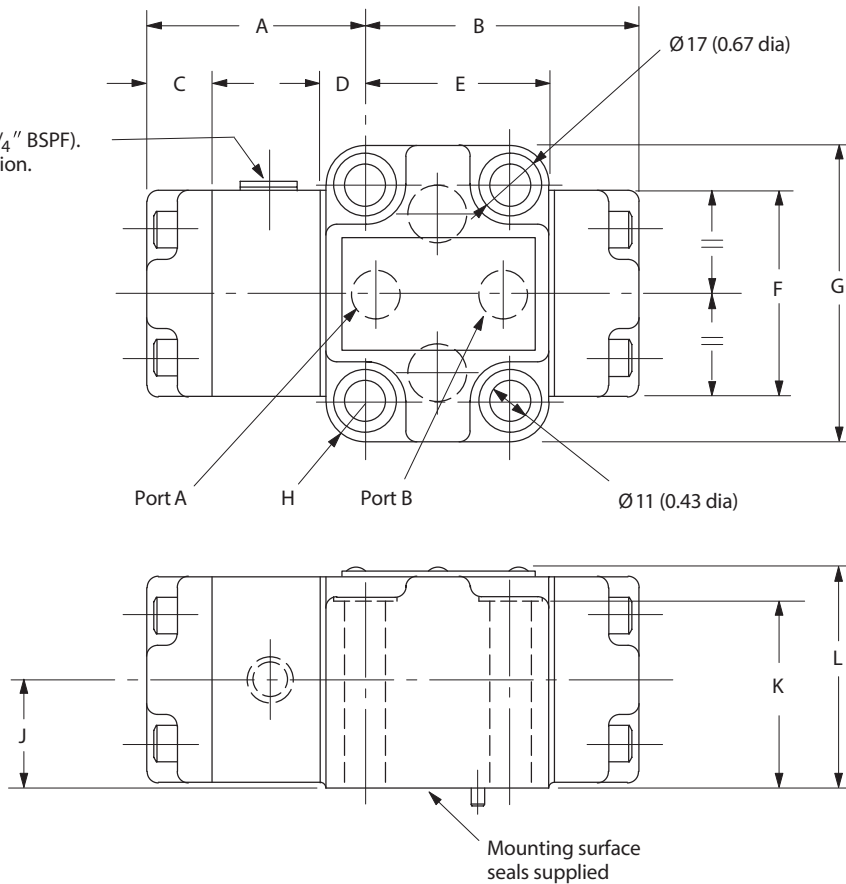

For port functions see "Mounting Surfaces", page 8

Model	A	B	C	D	E	F	G	H
PCGV-6*(D)-10	38 (1.5)	82 (3.2)	24 (1.0)	12 (0.47)	55 (2.2)	62 (2.5)	89 (3.5)	10 (0.4)
PCGV-6*(D)-1-10	66 (2.6)	82 (3.2)	24 (1.0)	12 (0.47)	55 (2.2)	62 (2.5)	89 (3.5)	10 (0.4)
PCGV-8*(D)-10	38 (1.5)	98 (3.9)	23 (0.9)	13 (0.5)	74 (2.9)	78 (3.1)	103 (4.1)	11 (0.45)
PCGV-8*(D)-1-10	66 (2.6)	98 (3.9)	23 (0.9)	13 (0.5)	74 (2.9)	78 (3.1)	103 (4.1)	11 (0.45)
PCG5V-6*(D)---20	–	82 (3.2)	–	12 (0.47)	55 (2.2)	62 (2.5)	89 (3.5)	10 (0.4)
PCG5V-6*(D)-1---20	–	82 (3.2)	–	12 (0.47)	55 (2.2)	62 (2.5)	89 (3.5)	10 (0.4)
PCG5V-8*(D)---20	–	98 (3.9)	–	13 (0.5)	74 (2.9)	78 (3.1)	103 (4.1)	11 (0.45)
PCG5V-8*(D)-1---20	–	98 (3.9)	–	13 (0.5)	74 (2.9)	78 (3.1)	103 (4.1)	11 (0.45)

Model	J	K	L	M	N
PCGV-6*(D)-10	–	56 (2.2)	68 (2.7)	–	–
PCGV-6*(D)-1-10	33 (1.3)	56 (2.2)	68 (2.7)	–	–
PCGV-8*(D)-10	–	60 (2.4)	72 (2.8)	–	–
PCGV-8*(D)-1-10	35 (1.4)	60 (2.4)	72 (2.8)	–	–
PCG5V-6*(D)---20	–	56 (2.2)	68 (2.7)	165 (6.5)	86 (3.4)
PCG5V-6*(D)-1---20	–	56 (2.2)	68 (2.7)	165 (6.5)	114 (4.5)
PCG5V-8*(D)---20	–	60 (2.4)	72 (2.8)	168 (6.6)	86 (3.4)
PCG5V-8*(D)-1---20	–	60 (2.4)	72 (2.8)	168 (6.6)	114 (4.5)

PCG5V Models

With Type "U" Coil Connection

("U" at model code 8)

13,0 (0.5) for
plug removal

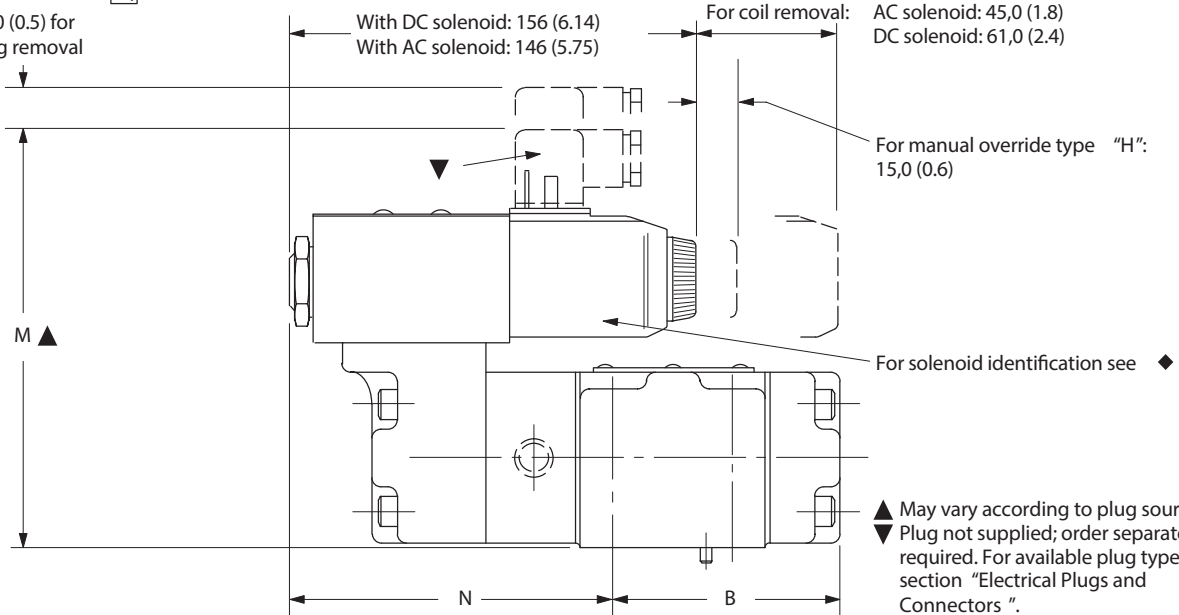

With Type "F**" Coil Connection

("F(T)J " or "F(T)W " at model code 8)

Ground (earth) connection:
Ø0,4 (0.16 dia) self-tapping
screw

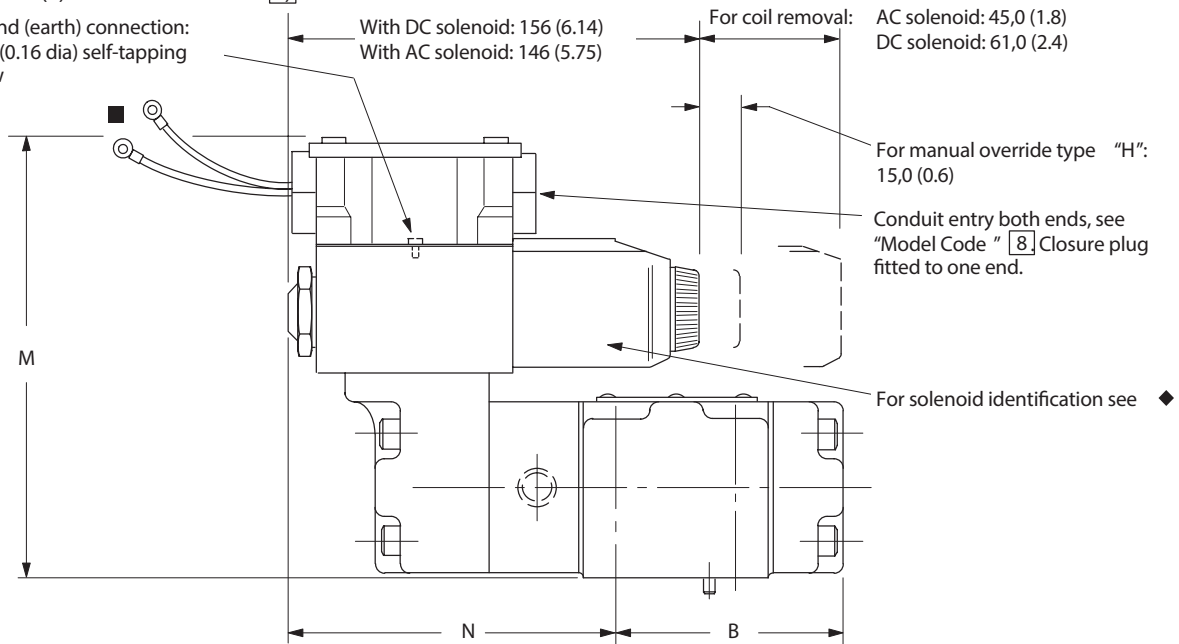

◆ The solenoid identification is printed on the nameplate of the pilot valve. Identification options are described under "Model Code " 7 ".

For ANSI/NFPA method (no symbol at model code 7) solenoid identity is: "Sol. A ".

For German method ("V" in model code 7) solenoid identity is: "Sol. B ".

■ Ref. model code 8:

Codes "FJ " and "FW " : 2 lead wires for each solenoid, approx. 150,00 (6.0) long. M3 terminals provided for customer connection.

Codes "FTJ " and "FTW " : lead wires connected into terminal strip suitable for M3 terminals on customer connection.

Mounting Surfaces, Based on

ISO 5781, Codes:

AG-06-2-A

AH-08-2-A

When a subplate is not used a raised machined pad must be provided for mounting. The pad must be flat within 0,01mm/100 mm (0.001 "/10") and smooth within 0,8 μm (32 μin).

Dimensional tolerances are ±0,2 mm (0.008 ") except where indicated.

Port functions

A = Free flow inlet and controlled reverse flow outlet

B = Free flow outlet and controlled reverse flow inlet

X = Pilot control port

Y = External drain port

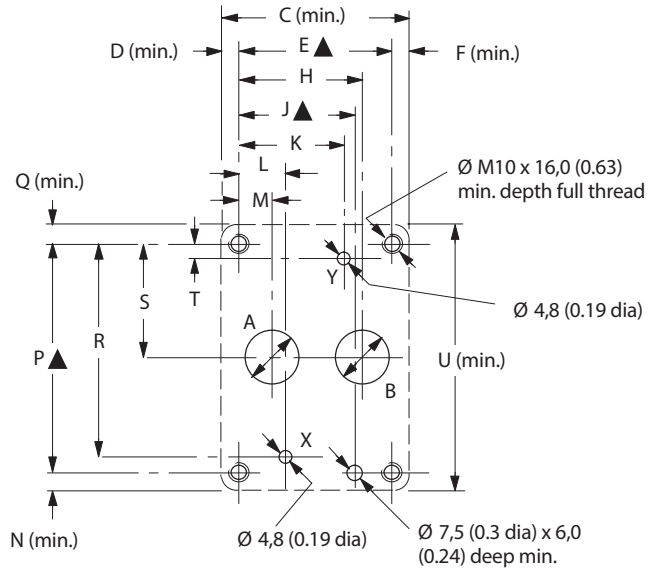

Size	A dia.	B dia.	C	D	E	F	H	J	K
06	14,7 (0.58)	14,7 (0.58)	61,0 (2.4)	9,0 (0.4)	42,9 (1.69)	9,0 (0.4)	35,7 (1.4)	31,8 (1.25)	21,4 (0.84)
08	23,4 (0.92)	23,4 (0.92)	78,0 (3.1)	8,8 (0.35)	60,3 (2.37)	8,8 (0.35)	49,2 (1.94)	44,5 (1.75)	39,7 (1.56)

Size	L	M	N	P	Q	R	S	T	U
06	21,4 (0.84)	7,1 (0.28)	10,0 (0.4)	66,7 (2.62)	10,0 (0.4)	58,7 (2.3)	33,3 (1.3)	7,9 (0.31)	87,0 (3.4)
08	20,6 (0.81)	11,1 (0.44)	10,8 (0.43)	79,4 (3.125)	10,8 (0.43)	73,0 (2.87)	39,7 (1.56)	6,4 (0.25)	101,0 (4.0)

▲ Tolerance on bolt and pin locations ±0,1 mm (0.004 ")

XCGVM-6-10R Subplate

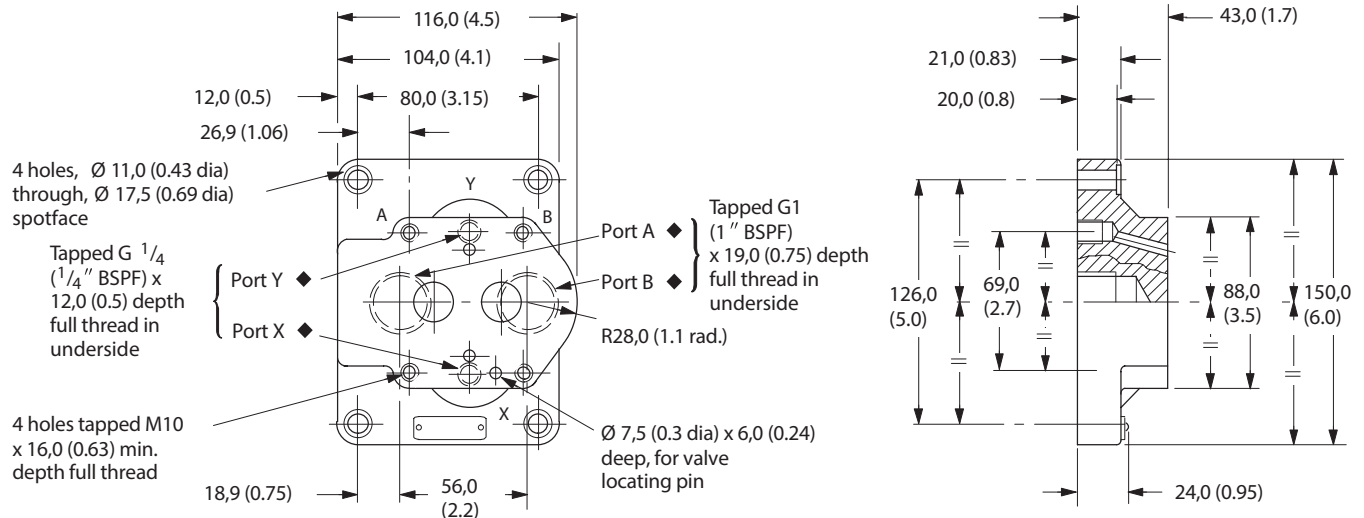

◆ See "Mounting Surfaces " section above for port usage

Installation Data

Mounting Attitude

Unrestricted.

Subplates

For PCG(5)V-6 valves see type XCVGM-6-10R, on previous page.
For PCG(5)V-8 valves consult your Vickers representative.

Mounting Bolts/Torques

For PCG(5)V-6 valves:

bolt kit BKPCGV-6.

For PCG(5)V-8 valves:

bolt kit BKPCGV-8.

Bolts should be torqued to 59-73 Nm (44-53 lbf ft), with threads lubricated.

Mass (approx.)

	PCG(5)V-6 kg (lb)	PCG(5)V-8 kg (lb)
PCGV with internal drain	3,2 (7)	4,9 (10.8)
PCGV with external drain	4,0 (8.8)	5,9 (13)
PCG5V with internal drain ▲		
AC voltage models	5,7 (12.6)	7,3 (16.1)
DC voltage models	5,9 (13)	7,5 (16.5)
PCG5V with external drain ▲		
AC voltage models	6,5 (14.3)	8,3 (18.3)
DC voltage models	6,7 (14.8)	8,5 (18.7)

▲ Pilot piston drain.

XCVGM-6-10R subplate: 3,0 kg (6.6 lb)

For valves with type "U" coils (see model code).

The cable entry on these plugs can be repositioned at 90 ° intervals by reassembly of the contact holder relative

to the plug housing. The cable entry is Pg 11 for cable Ø 6-10 mm (0.24-0.40 " dia).

Order plugs separately by part number.

Electrical Plugs and Connectors

Plugs for ISO 4400 (DIN 43650) Type Coil Connection

Voltage	Part number	
	Gray (Sol. A)	Black (Sol. B)
Without indicator light		
-	710776	710775
With indicator light		
12-24V	977467	977466
100-125V	977469	977468
200-240V	977471	977470

Terminal Strip and Lights

For valves with type "F**" coils, see model code location 8

For "FTJ " or "FTW " at model code 8

For "FTJL " or "FTWL " at model code 8H 9

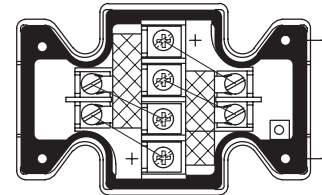
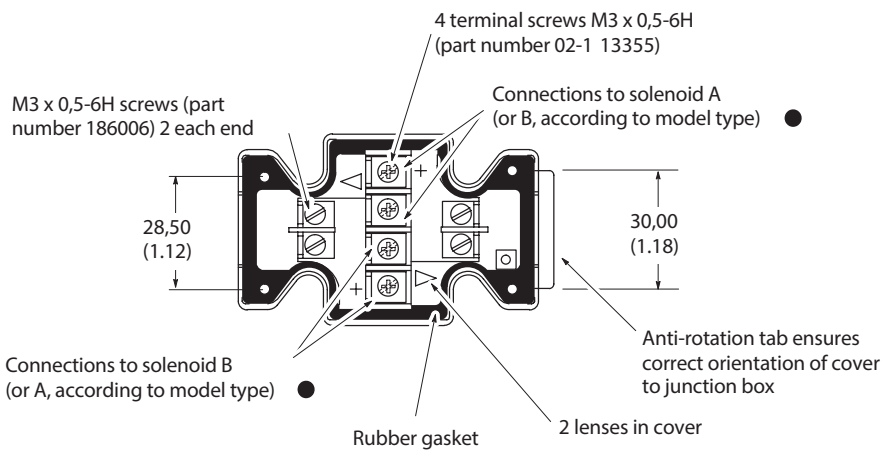
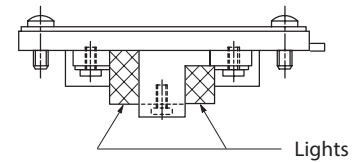
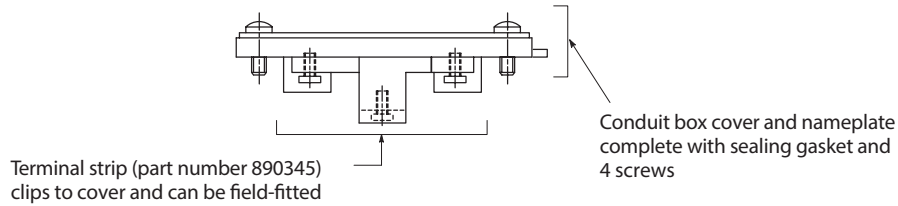

● 1. For DC coils the +ve lead(s) must be connected to the terminal(s) marked +. When using 3-wire incoming leads to double solenoid valves (i.e. common neutral) the inner pair of terminals must be linked.

2. For correct light indication of energized solenoid ensure that solenoid leads are correctly connected: light terminals are common with each outer pair of solenoid terminals according to the side with + mark.

Ordering Procedure

Valves, subplates and bolt kits should be ordered by full model code designation.

Products we offer:

- Cartridge valves
- DCV directional control valves
- Electric converters
- Electric machines
- Electric motors
- Gear motors
- Gear pumps
- Hydraulic integrated circuits (HICs)
- Hydrostatic motors
- Hydrostatic pumps
- Orbital motors
- PLUS+1® controllers
- PLUS+1® displays
- PLUS+1® joysticks and pedals
- PLUS+1® operator interfaces
- PLUS+1® sensors
- PLUS+1® software
- PLUS+1® software services, support and training
- Position controls and sensors
- PVG proportional valves
- Steering components and systems
- Telematics

Danfoss Power Solutions is a global manufacturer and supplier of high-quality hydraulic and electric components. We specialize in providing state-of-the-art technology and solutions that excel in the harsh operating conditions of the mobile off-highway market as well as the marine sector. Building on our extensive applications expertise, we work closely with you to ensure exceptional performance for a broad range of applications. We help you and other customers around the world speed up system development, reduce costs and bring vehicles and vessels to market faster.

Danfoss Power Solutions – your strongest partner in mobile hydraulics and mobile electrification.

Go to www.danfoss.com for further product information.

We offer you expert worldwide support for ensuring the best possible solutions for outstanding performance. And with an extensive network of Global Service Partners, we also provide you with comprehensive global service for all of our components.

Local address:

Hydro-Gear

www.hydro-gear.com

Daikin-Sauer-Danfoss

www.daikin-sauer-danfoss.com

Danfoss Power Solutions (US) Company
2800 East 13th Street
Ames, IA 50010, USA
Phone: +1 515 239 6000

Danfoss Power Solutions GmbH & Co. OHG
Krokamp 35
D-24539 Neumünster, Germany
Phone: +49 4321 871 0

Danfoss Power Solutions ApS
Nordborgvej 81
DK-6430 Nordborg, Denmark
Phone: +45 7488 2222

Danfoss Power Solutions Trading (Shanghai) Co., Ltd.
Building #22, No. 1000 Jin Hai Rd
Jin Qiao, Pudong New District
Shanghai, China 201206
Phone: +86 21 2080 6201