

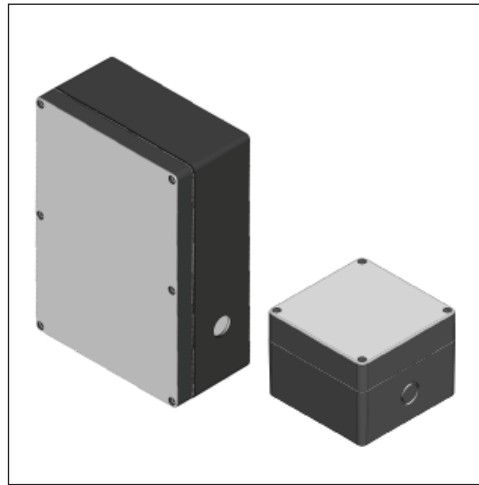

Application:



The WP35, WP37 and WP39 weatherproof enclosures are specifically designed for certain AB-QM valve sizes and actuator assemblies.

WP37

- Brass valve sizes of AB-QM mounted with the actuators:

- AMI 140 / AMV 110NL / AME 110NL
- ABNM LIN/LOG series
- TWA / ABRA / ABLV

WP35

- 1½" and 2" AB-QM mounted with the actuators:

- AME 435QM / AMV 435

WP39

- 2½" and 4" AB-QM mounted with the actuators:

- AME 435QM / AMV 435
- AME 25 SU/SD

Features:

- Silicone rubber gasket between cover and enclosure
- Durable enclosure and impact-resistant
- UV Stabilized Polycarbonate material
- Stainless steel screws for easy removal of cover

Ordering Information:

Code No.	Enclosure Dimensions (L x W x H), inches (mm)	Material
WP35	10.4 x 7.3 x 3.7 (264.9 x 184.9 x 95)	Polycarbonate, Lexan
WP37	4.72 x 4.72 x 3.53 (119.9 x 119.9 x 89.7)	
WP39	12.6 x 10.5 x 7.1 (320.0 x 266.7 x 180.3)	

Technical Information:

	WP35	WP37	WP39
For AB-QM valve sizes	1½" and 2"	½", ¾", 1" and 1¼"	2½" to 4"
Specific AB-QM actuators	AME15QM, AME435QM, AMV(E)435	All thermo-actuators, AMI140, AME110NL, AMV110NL	AMV(E)435 & AME25 series actuator
Enclosure material	Polycarbonate, Lexan		
Enclosure box rating	NEMA 4x, 12 and 13		NEMA 6P
Electrical wire penetration	Accommodates for ½" weatherproof conduit fitting (not included)		



Installation & Orientation

The installation orientation of the valve assembly and enclosure should not be pointing down. Valve assembly and enclosure should be in an upright orientation.

Provide sufficient room around the enclosure's cover to allow the removal and access to the valve assembly.

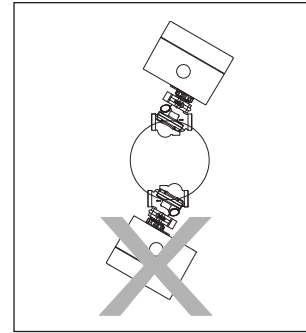

Electrical Connection

Proper supplying of power to the actuator within the enclosure requires the use of a weather proof conduit fitting (fitting not provided) to be installed to the enclosure.

WP35 & WP39 Enclosure

A pre-drilled 1/2" conduit hole has been provided.

WP37 Enclosure

A 1/2" conduit knock out is located on opposite sides of the enclosure. The knock out requires to be drilled out to accommodate the fitting.

Dimensions

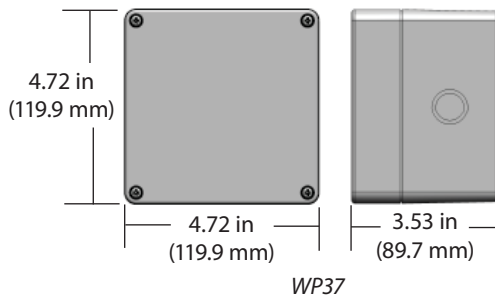
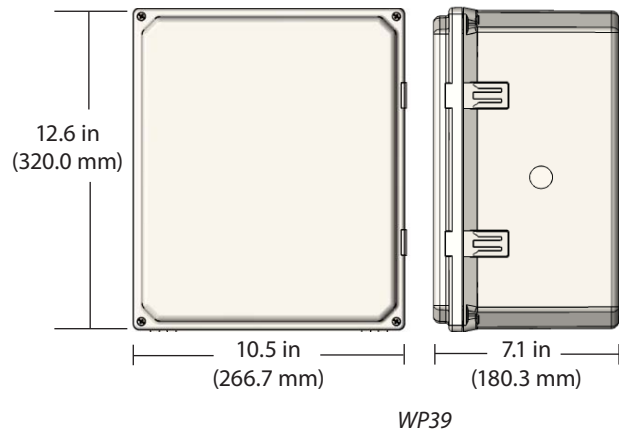
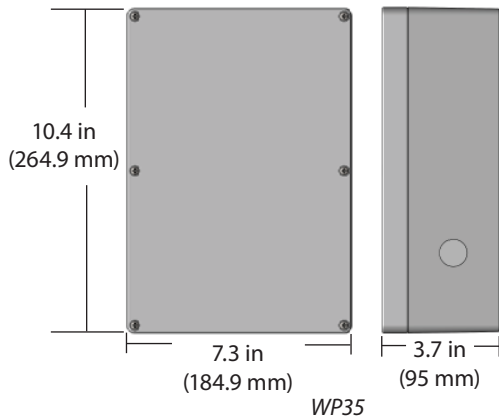

Danfoss can accept no responsibility for possible errors in printed materials and reserves the right to alter its products without notice. All trademarks in this material are property of the respective companies. Danfoss and Danfoss logotype are trademarks of Danfoss A/S. All rights reserved.



Danfoss
 Toronto, ON
 Toll Free: 866-375-HVAC (4822)
 Tel.: 905-285-2050, Fax: 905-285-2055
 www.na.heating.danfoss.com

Danfoss
 Baltimore, MD
 Toll Free: 866-375-HVAC (4822)
 Tel.: 443-512-0266, Fax: 443-512-0270
 www.na.heating.danfoss.com