



Model AB-QM Pressure Independent Balance and Control Valve

CONTROL VALVE SUBMITTAL, 2½” thru 4” valves, ANSI FLANGED, (2nd gen)

DATE _____ SPEC. SECTION _____ PAGE _____ OF _____

<u>PROJECT</u> <u>SUPPLIER</u> ORDER NO.	<u>ARCHITECT/ENGINEER</u> <u>CONTRACTOR</u>
--	--

APPROVALS			
AGENCY	REPRESENTATIVE	DATE	NOTES
ARCHITECT			
ENGINEER			
CONTRACTOR 1			
CONTRACTOR 2			
(OTHER)			
NOTE	COMMENT		



Model	Number	Unit Tag	Qty
2½”			
3”			
4”			

Description

The AB-QM temperature control valve provides pressure independent regulation of flow while also providing flow limiting system balance. The unique differential pressure regulator dynamically adjusts to normal changes in system pressure from valves opening and closing or changing of pump speed.

- Constant differential pressure across control valve, resulting in 100% valve authority
- Balancing valve dynamic adjustment to maintain constant flow
- Variety of actuator signal combinations: Modulating, 3-point floating
- Adjustment collar and locking mechanism for flow setting

Specification

The valve shall be pressure independent and control pressure across the control valve orifice. The regulation of pressure shall be through an integrated EPDM diaphragm design, stainless steel spring, pressure control disc and require no internal maintenance or replaceable cartridges. Pressure control seat shall be brass construction with vulcanized EPDM. The adjustment method shall indicate percentage of valve flow range and utilize spring locked mechanism for adjustment. The valve assembly shall provide 100% control valve authority and maintain a linear flow characteristic. The valve shall accurately control the flow with an operating pressure differential range of 4 to 60psi for valve sizes 2½” to 4”. Verification of the pressure regulator and flow rate shall be provided by three PT locations on the valve.

Nominal Diameter	2½”	3”	4”
Code No.	003Z0783	003Z0784	003Z0785
Max. Flow (GPM)	85	120	165
Connection	ANSI Flange, 1/16” Raised Face (ANSI Standard B16.1)		
Connection rating	ANSI Class 125		
Controlled ΔP range	4 thru 60 psi (0.28 thru 4.0 bar)		
Differential pressure loss of open valve	4.0 psi		
Control valve characteristics	Linear		
Max. close off differential pressure (across the valve)	Dependent on actuator selected for valve size		
Max. static (hold) pressure	300 psi (20 bar)		
Medium temperature	15°F to 250°F (-10°C to 120°C)		
Allowable fluid	Water and secondary refrigerant additives such as glycol		
Shut off function	Acc. to ISO 5208 class A - no visible leakage		



Model AB-QM Pressure Independent Balance and Control Valve

CONTROL VALVE SUBMITTAL, 2½” thru 4” valves, ANSI FLANGED, (2nd gen)

Electric Actuator for 2½” to 4” ABQM Valves

Style	Code No.	Power	Input Signal			Output Signal (0-10VDC)	Safety Function	
			On/Off	Floating	Modulating		Up	Down
AME 435QM	082H0171	24Vac			•	•		
AMV435	082H0162	24Vac		•		•		
AME 25SU ¹	082H3041	24Vac		•	•	•	•	
AME 25SD ¹	082H3038	24Vac		•	•	•		•

¹ Adapter required, code no. 003Z0694

Flow Adjustment

On site flow adjustment of the valve can be done by rotation of the AB-QM valve neck to the flow percentage requirement and then locking the position via integrated Allen key screw.

Note: 1 turn= 10%

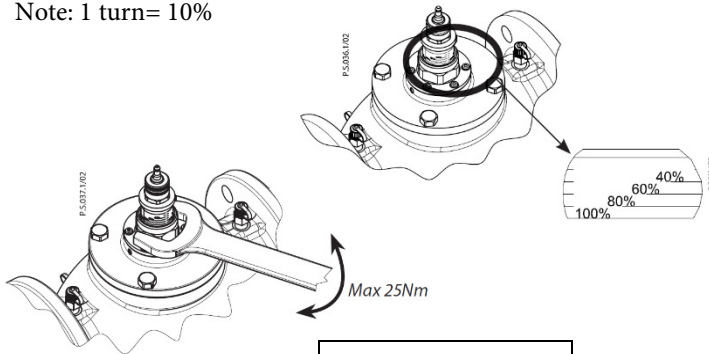

Max. flow	Flow (GPM)		
	85.0	120.0	165.0
Setting	2-1/2"	3"	4"
40%	34.0	48.0	66.0
45%	38.3	54.0	74.3
50%	42.5	60.0	82.5
55%	46.8	66.0	90.8
60%	51.0	72.0	99.0
65%	55.3	78.0	107.3
70%	59.5	84.0	115.5
75%	63.8	90.0	123.8
80%	68.0	96.0	132.0
85%	72.3	102.0	140.3
90%	76.5	108.0	148.5
95%	80.8	114.0	156.8
100%	85.0	120.0	165.0

Materials in Contact with Water

Valve bodies	Grey iron EN-GJL-250(GG25)
Membranes/ Bellow	EPDM
O-rings	EPDM
Springs	W.Nr. 1.4568, W.Nr. 1.4310
Cone (Pc)	CuZn40Pb3 -CW 614N, W.Nr. 1.4305
Seat (Pc)	W.Nr. 1.4305
Cone (Cv)	CuZn40Pb3 -CW 614N
Seat (Cv)	W.Nr. 1.4305
Screw	Stainless Steel (A2)

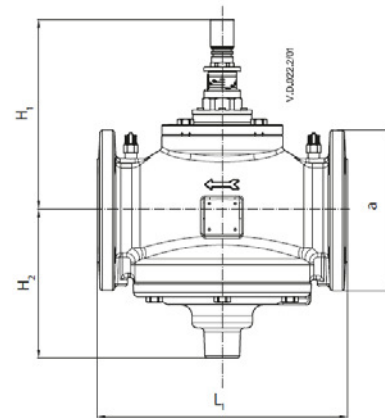

Valve size	Dimensions, in (mm)				Weight lb (kg)
	L1	H1	H2	a (ANSI B16.1)	
2-½"	11.4 (290)	9.2 (233)	6.8 (172)	7.1 (180)	84 (38)
3"	12.2 (310)	9.3 (236)	7.0 (177)	7.5 (190)	99 (45)
4"	13.8 (350)	9.8 (249)	7.4 (187)	9.1 (230)	126 (57)

Danfoss can accept no responsibility for possible errors in printed materials and reserves the right to alter its products without notice. All trademarks in this material are property of the respective companies. Danfoss and Danfoss logotype are trademarks of Danfoss A/S. All right reserved.



Head Office:
Danfoss Inc.
Mississauga, ON CANADA

Tel: 888.326.3677 (option 3) Fax: 416.352.5981
www.heating.danfoss.us

USA Office:
Danfoss Inc.
Baltimore, MD USA