

Fact sheet

HRU – Heat Recovery Unit



Designed for heat recovery

The Heat Recovery Unit is designed to recover the waste heat from refrigeration installations, where CO₂ is used. Recovered heat can be used for own heating purposes or returned to District Heating Utility network. It suits perfectly for supermarkets equipped with refrigerators. System include heating substation with accumulation tanks.

Remote controlling and monitoring

Danfoss automatic controller ECL offers more possibilities for external communication. Traditional SCADA solutions can communicate with the controller via a Modbus protocol. Further Danfoss offers a web-based SCADA solution called ECL portal (ecl.portal.danfoss.com), which enables remote controlling, monitoring and alarming functionalities from the sub-station. Visualization of the ECL portal gives you easiness of use, and access via PC or Smartphone improves the level of service and reduce costs due to 24/7 access.

Construction / installation

Heat Recovery Unit is designed as floor station and it is delivered in one piece, with possibility to be split into 3 parts, which allows to transport station thru narrow corridors. All heat exchangers are produced in Micro Plate technology develop by Danfoss, which significantly increase substation performance and lifetime. Standard unit layout allows to prepare connection piping inside the building before station is delivered. Piping prepared with automatic welding machines ensure highest possible welding quality.

Friendly solution for climate

Heat recovery unit is environmental friendly as it saves globe from unnecessary CO₂ emissions. Especially supermarkets can accumulate excess heat from cooling systems to heat up shop area. In some areas waste heat via heating networks can be transferred to household. System efficiency ensure short "return of investment" time and allows to save money for heating in longer term.

FEATURES AND BENEFITS

- Substations with high quality components designed for heat recovery applications fully customized by use of 3D-tools to fit individual needs
- All control components in the substation are high quality Danfoss components like: heat exchanger, control valves, shut-off valves, energy meter, shut-off valves and automatic controls
- Danfoss prefabricated substations reduces space demand approximately 30% compared to build-on-site solutions
- Easy to install and use with remote access via Danfoss free cloud based ECL portal or via other communication protocols like MODBUS
- All Danfoss products are manufactured according PED 97/23/ EC European Pressure Directive, and Danfoss is compliant to ISO9001/ISO14001/ IATF 16949 automotive

Prefabricated substations enable top quality and shorten installation work on the building site

The Heat Recovery units are produced based on a 3D models prepared by our design department. All components like: heat exchangers, control valves, pumps and measuring equipment are virtually connected with piping. Based on 3D-drawings pipes are bent, cut and welded with support of automated machines ensuring supreme quality and short delivery time. Units are designed as modular constructions, which makes transportation and assembly easier. Heating units includes an electrical wired panel, which is functionally tested and ready to use after connecting power supply to the cooling substation on site. Danfoss substation is a complete product: designed, produced and tested – ready for use. Danfoss has more than 40 years of experience in production of substations, which guarantees great functionality.

Need a design of substation? Just send us:

- Heating demand
- CO₂ heat capacity

CIRCUIT DIAGRAM

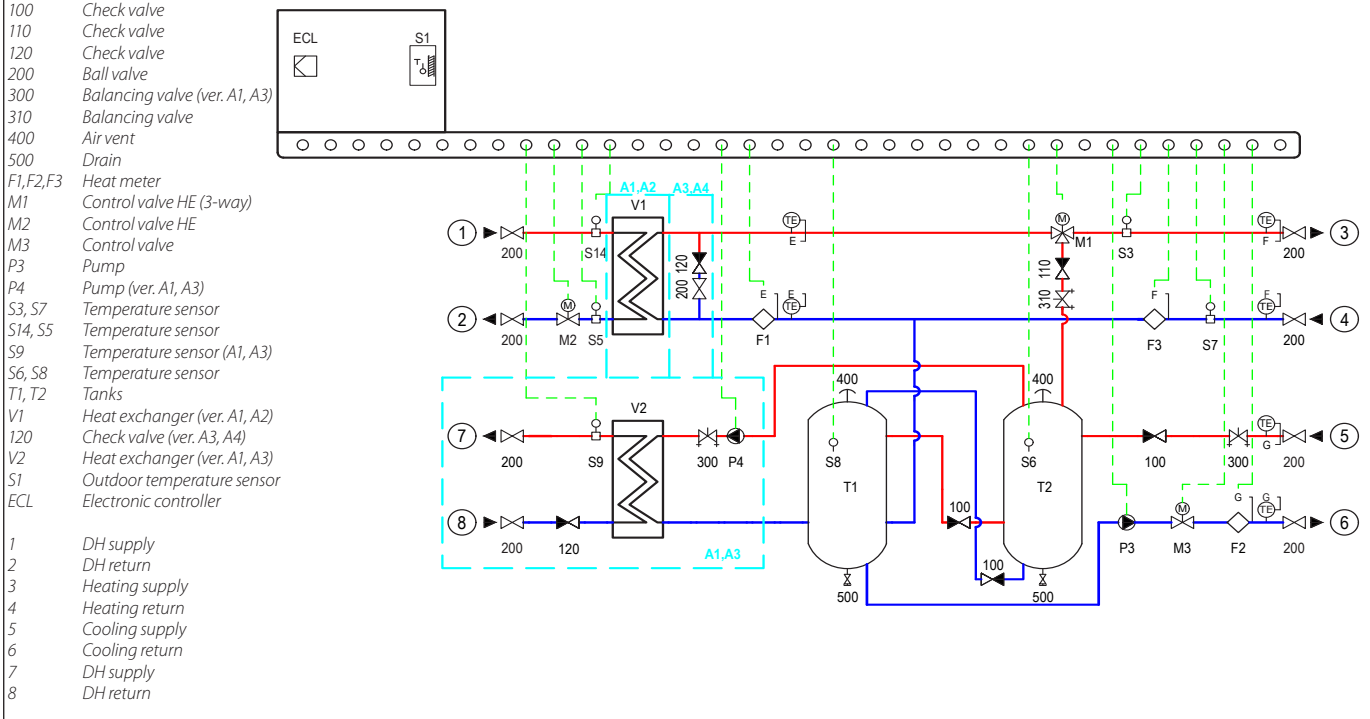

Technical parameters

Primary side

Maximum temperature: 90 °C
 Nominal pressure: PN 10
 Diameter (threaded): DN 40

Secondary side

Maximum temperature (A1 / A2): 70 °C
 Maximum temperature (A3 / A4): 90 °C
 Nominal pressure (A1 / A2): PN 6
 Nominal pressure (A3 / A4): PN 10
 Diameter (threaded): DN 40
 Electrical supply: 230V AC
 Controller: ECL 310

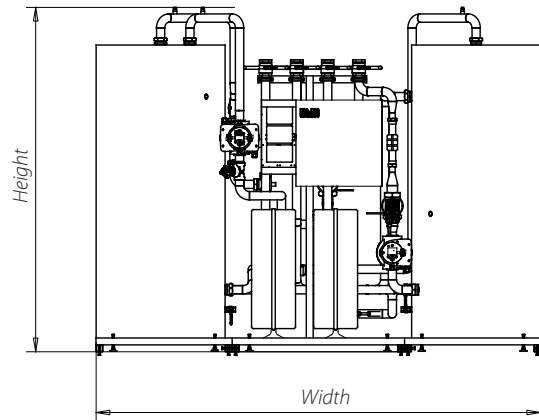
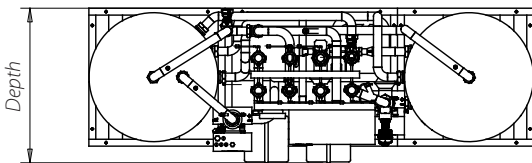

CAPACITY, WEIGHT AND DIMENSIONS

Type	Capacity [kW]		V1	V2	M1	M2/M3	Weight [kg]	External dimensions [mm]		
	Heating	CO ₂						Height	Width	Depth
A1	14 ÷ 540	50 ÷ 400	XB37/XB59	XB37/XB59	VRB3 + AMV	AHQM + AMV	up to 500	2000	2700	1200
A2			XB37/XB59	—						
A3			DN 40	XB37/XB59						
A4			DN 40	—						

Danfoss Poland Sp. z o.o. · Tuchom, ul. Tęczowa 46 · 80-209 Chwaszczyno · POLAND
 Tel.: +48 58 512 91 34 · Fax: +48 58 512 91 05 · serwis@danfoss.pl · www.danfoss.com

Danfoss can accept no responsibility for possible errors in catalogues, brochures and other printed material. Danfoss reserves the right to alter its products without notice. This also applies to products already on order provided that such alterations can be made without consequential changes being necessary in specifications already agreed. All trademarks in this material are property of the respective companies. Danfoss and the Danfoss logotype are trademarks of Danfoss A/S. All rights reserved.