

Refrigeration

- an introduction to the basics

Automatic Controls and Compressors for refrigeration



Automatic controls for commercial refrigeration



Automatic controls for Industrial refrigeration



Electronic controls for refrigeration



Appliance controls



Compressors for household and commercial refrigeration



Condensing units

Refrigeration - an introduction to the basics

This Danfoss publication must be regarded as a supplement to the comprehensive literature on refrigeration that is available today and which is primarily aimed at readers with a professional relationship to the refrigeration industry/trade e.g. refrigeration engineers and installers.

The contents of this book are intended to interest those who are not engaged every day with refrigeration plant but who wish to extend their knowledge on the basic principles of appliances they see every day.

When compiling the material for the booklet a deliberate attempt was made to provide a thorough description of the elementary principles involved together with an explanation in everyday language of the practical design of the individual components.

For additional training material we refer to:

<http://www.danfoss.com/BusinessAreas/RefrigerationAndAirConditioning>

Choose "Training & Education".

Nordborg, 2007

Contents

1. Introduction	3
2. Fundamental terms	4
2.1 Unit systems.....	4
2.2 Temperature.....	4
2.3 Force and pressure.....	5
2.4 Heat, work, energy and power.....	5
2.5 Substances and phase change.....	6
2.6 Latent heat.....	7
2.7 Superheat.....	7
2.8 Refrigerant diagrams.....	8
3. Refrigerant circuit	9
3.1 Evaporator.....	9
3.2 Compressor.....	9
3.3 Compressor, method of operation.....	9
3.4 Condenser.....	10
3.5 Expansion process.....	10
3.6 High and low pressure sides of the refrigeration plant.....	10
4. Refrigeration process, pressure/enthalpy diagram	11
5. Refrigerants	12
5.1 General requirements.....	12
5.2 Fluorinated refrigerants.....	12
5.3 Ammonia NH ₃	12
5.4 Secondary refrigerants.....	12
6. Refrigeration plant main components	13
6.1 Compressor.....	13
6.2 Condenser.....	13
6.3 Expansion valve.....	15
6.4 Evaporation systems.....	16
7. The practical build-up of a refrigeration plant	17

1. Introduction

The job of a refrigeration plant is to cool articles or substances down to, and maintain them at a temperature lower than the ambient temperature. Refrigeration can be defined as a process that removes heat.

The oldest and most well-known among refrigerants are ice, water, and air. In the beginning, the sole purpose was to conserve food. The Chinese were the first to find out that ice increased the life and improved the taste of drinks and for centuries Eskimos have conserved food by freezing it.

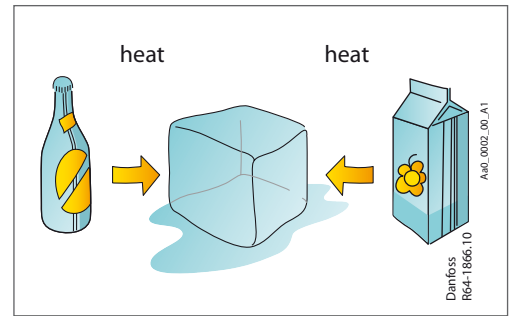

At the beginning of the last century, terms like bacteria, yeast, mould, enzymes etc. were known. It had been discovered that the growth of microorganisms is temperature-dependent, that growth declines as temperature falls, and that growth becomes very slow at temperatures below +10 °C.

As a consequence of this knowledge, it was now possible to use refrigeration to conserve foodstuffs and natural ice came into use for this purpose.

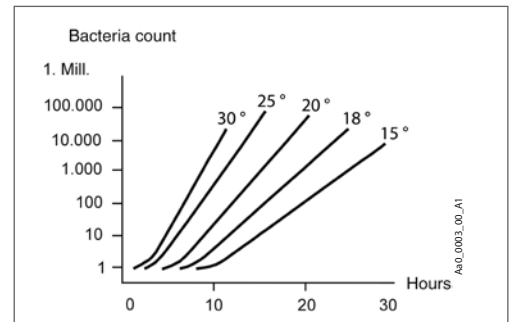

The first mechanical refrigerators for the production of ice appeared around the year 1860. In 1880 the first ammonia compressors and insulated cold stores were put into use in the USA.

Electricity began to play a part at the beginning of this century and mechanical refrigeration plants became common in some fields: e.g. breweries, slaughter-houses, fishery, ice production, for example.

After the Second World War the development of small hermetic refrigeration compressors evolved and refrigerators and freezers began to take their place in the home. Today, these appliances are regarded as normal household necessities.

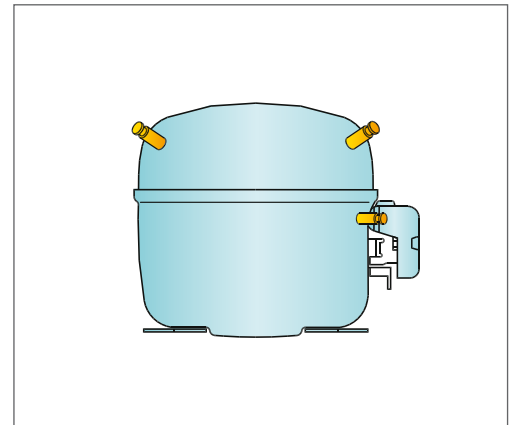

There are countless applications for refrigeration plants now. Examples are:

- Foodstuff conservation
- Process refrigeration
- Air conditioning plants
- Drying plants
- Fresh water installations
- Refrigerated containers
- Heat pumps
- Ice production
- Freeze-drying
- Transport refrigeration

In fact, it is difficult to imagine life without air conditioning, refrigeration and freezing - their impact on our existence is much greater than most people imagine.

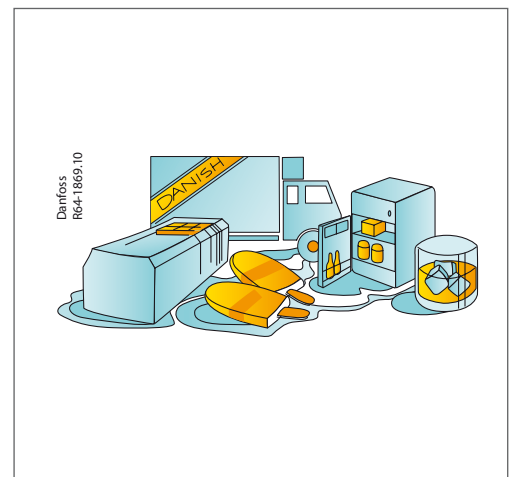

2. Fundamental terms

2.1 Unit systems

On an international level, agreement has been reached on the use of the *Systeme International d'Unités* - often referred to as the *SI-system*. For a number of countries the implementation of the SI-system is still an on-going process.

In this booklet the SI-system will be the primary unit system used. However, in many parts of the refrigeration community it is still practice to use metric units or other alternative units. Therefore, the practically used alternative units will be given in parenthesis where needed.

The table shows the SI-units and the other often used alternative units for the quantities that are used in this booklet.

Quantity	SI-unit	Alternative units
Time	s (second)	h (hour)
Length	m (meter)	in (inch) ft (foot)
Mass	kg (kilogram)	lb (pound)
Temperature	K (Kelvin)	°C (Celsius) °F (Fahrenheit)
Force	N (Newton)	kp (kilopond)
Pressure	Pa (Pascal) = N/m ²	bar atm (atmosphere) mm Hg (millimeter mercury column) psi (pound per square inch)
Energy	J (Joule) = Nm	kWh (kilowatt hour) cal (calorie) Btu (British thermal unit)
Power	W (Watt) = J/s	calorie/h, Btu/h

The practical use of the SI-units is strongly associated with the use of the decadic prefixes to avoid writing either very small or large numbers. A part of the prefixes used can be seen in the table below.

Example:

The atmospheric air pressure is 101325 Pa. Using the decadic prefixes from the table below the best way of writing this would be 101.325 kPa.

The choice of prefix is "free" but the best choice will normally be the one where the value written will be in the range from 0.1 to 999.9.

Prefixes should not be used for combined SI-units - except when [kg] is used.

Example:

2000 W/m² K should be written as 2.000 × 10³ W/m² K and not as 2 kW/m² K.

Name	pico	nano	micro	mili	kilo	Mega	Giga	Tera	Peta
Prefix	p	n	μ	m	k	M	G	T	P
Factor	10 ⁻¹²	10 ⁻⁹	10 ⁻⁶	10 ⁻³	10 ³	10 ⁶	10 ⁹	10 ¹²	10 ¹⁵

2.2 Temperature

Temperature is a very central property in refrigeration. Almost all refrigeration systems have the purpose of reducing the temperature of an object like the air in a room or the objects stored in that room.

The SI-unit for temperature *Kelvin [K]* is an absolute temperature because its reference point [0 K] is the lowest temperature that it in theory would be able to obtain.

When working with refrigeration systems the temperature unit *degree Celsius [°C]* is a more practical unit to use. Celsius is not an absolute

temperature scale because its reference point (0 °C) is defined by the freezing point of water (equal to 273.15 K).

The only difference between Kelvin and Celsius is the difference in reference point. This means that a temperature difference of 1 °C is exactly the same as a temperature difference of 1 K.

In the scientific part of the refrigeration community temperature differences are often described using [K] instead of [°C]. This practice eliminates the possible mix-up of temperatures and temperature differences.

Fundamental terms

2.3 Force and pressure

The SI-unit for force is *Newton (N)* which is actually a $[kg\ m/s^2]$.

A man wearing skis can stand in deep snow without sinking very deep - but if he steps out of his skis his feet will probably sink very deep into the snow. In the first case the weight of the man is distributed over a large surface (the skis). In the second case the same weight is distributed on the area of his shoe soles - which is a much smaller area than the area of the skis. The difference between these two cases is the pressure that the man exerts on the snow surface.

Pressure is defined as the force exerted on an area divided by the size of the area. In the example with the skier the force (gravity) is the same in both cases but the areas are different. In the first case the area is large and so the pressure becomes low. In the second case the area is small and so the pressure becomes high.

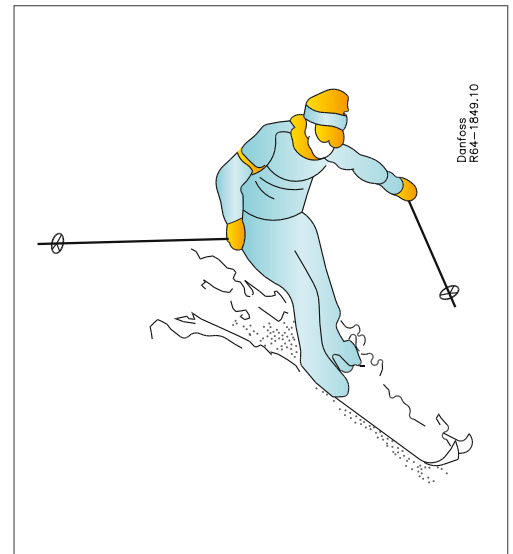

In refrigeration pressure is mostly associated with the fluids used as refrigerants. When a substance in liquid or vapour form is kept within a closed container the vapour will exert a force on the inside of the container walls. The force of the vapour on the inner surface divided by its area is called the *absolute* pressure.

For practical reasons the value for pressure is sometimes stated as "pressure above atmospheric pressure" - meaning the atmospheric pressure ($101.325\ kPa = 1.013\ bar$) is subtracted from the absolute pressure. The pressure above atmospheric pressure is also often referred to as *gauge* pressure.

The unit used should reflect the choice of absolute pressure or gauge pressure. An absolute pressure is indicated by the use of lowercase "a" and a gauge pressure is indicated by a lowercase "g".

Example:
The absolute pressure is 10 bar(a) which converted to gauge pressure becomes $(10 - 1.013)\ bar(g) \approx 9\ bar(g)$. The combination of the SI-unit for pressure [Pa] and the term gauge pressure is not recommended.

Other units for pressure that are still used today are *mm of mercury column [mmHg]*, and *meter water gauge [mwg]*. The latter is often used in connection with pumps to indicate the height of the water column that the pump is able to generate.

Vacuum is defined as an absolute pressure of 0 Pa - but since it is almost impossible to obtain this the term "vacuum" is used generally to describe a pressure much lower than the atmospheric pressure. Example: The absolute pressure is 0.1 bar(a) which converted to gauge pressure becomes $(0.1 - 1.013)\ bar(g) \approx -0.9\ bar(g)$. Vacuum is also often described in *Torr* (1 Torr is equal to 10 Pa) and *millibar* (a thousandth of a bar).

2.4 Heat, work, energy and power

Heat and work are both forms of energy that can be transferred between objects or systems. The transfer of heat is closely connected to the temperature (or temperature difference) that exists between two or more objects. By itself heat is always transferred from an object with high temperature to objects with lower temperatures. Heating of water in a pot on a stove is a good everyday example of the transfer of heat. The stove plate becomes hot and heat is transferred from the plate through the bottom of the pot and to the water. The transfer of heat to the water causes the temperature of the water to rise. *In other words, heating an object is the same as transferring energy (heat) to the object.*

In many practical applications there is a need to reduce the temperature of an object instead of increasing it. Following the example above this can only be done if you have another object with

a lower temperature than that of the object you wish to cool. Putting these two objects into contact will cause a transfer of heat away from the object you wish to cool and, consequently, its temperature will decrease. *In other words, cooling an object is the same as transferring energy (heat) away from the object.*

The transfer of work is typically connected to the use of mechanical shafts like the one rotating in an electric motor or in a combustion engine. Other forms of work transfer are possible but the use of a rotating shaft is the primary method used in refrigeration systems.

As mentioned both heat and work are forms of energy. The methods of transfer between objects are different but for a process with both heat and work transfer it is the sum of the heat and work transfer that determines the outcome of the process.

Fundamental terms

2.4 Heat, work, energy and power (cont.)

The SI-unit *Joule [J]* is used to quantify energy, heat and work. The amount of energy needed to increase the temperature of 1 kg of water from 15 to 16 °C is 4.187 kJ. The 4.178 kJ can be transferred as heat or as work - but heat would be the most used practical solution in this case.

There are differences in how much energy is required to increase the temperature of various substances by 1 K. For 1 kg of pure iron app. 0.447 kJ is needed whereas for 1 kg of atmospheric air only app. 1.0 kJ is needed. The property that makes the iron and air different with respect to the energy needed for causing a temperature increase is called the "specific heat capacity". It is defined as the energy required to cause a temperature increase of 1 K for 1 kg of the substance. The unit for specific heat capacity is *J/kg K*.

The rate at which energy is transferred is called *power*. The SI-unit for power is *Watt (W)*.

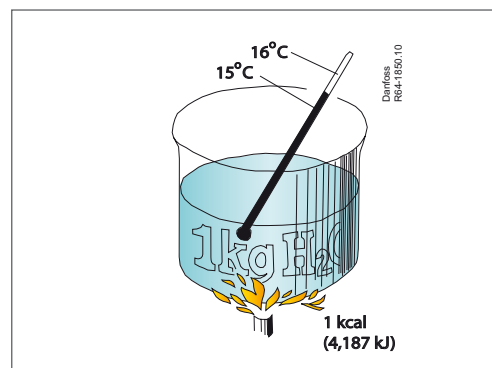

Example:

If 10 J is transferred per second, the rate of energy transfer is stated as 10 J/s = 10 W. In the SI-system the choice of unit for power is the same for transfer of heat and work. In other unit systems the transfer rates for heat and work could have different units.

2.5 Substances and phase change

All substances can exist in three different phases: solid, liquid, and vapour. Water is the most natural example of a substance that we use almost every-day in all three phases. For water the three phases have received different names - making it a bit confusing when using it as a model substance. The solid form we call ice, the liquid form we just call water, and the vapour form we call steam. What is common to these three phases is that the water molecules remain unchanged, meaning that ice, water, and steam all have the same chemical formula: H_2O .

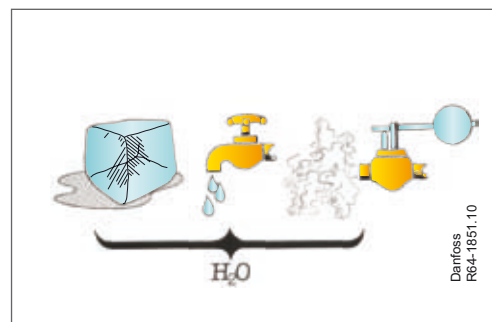

When taking a substance in the solid to the liquid phase the transition process is called melting and when taking it further to the vapour phase the transition process is called boiling (evaporation). When going in the opposite direction

taking a substance from the vapour to the liquid phase the transition process is called condensing and when taking it further to the solid phase the transition process is called freezing (solidification).

At constant pressure the transition processes display a very significant characteristic. When ice is heated at 1 bar its temperature starts rising until it reaches 0 °C - then the ice starts melting. During the melting process the temperature does not change - all the energy transferred to the mixture of ice and water goes into melting the ice and not into heating the water. Only when the ice has been melted completely will the further transfer of energy cause its temperature to rise. The same type of behaviour can be observed when water is heated in an open pot. The water

temperature increases until it reaches 100 °C - then evaporation starts. During the evaporation process the temperature remains at 100 °C. When all the liquid water has evaporated the temperature of the steam left in the pot will start rising.

The temperature and pressure a substance is exposed to determine whether it exists in solid, liquid, or vapour form - or in two or all three forms at the same time. In our local environment iron appears in its solid form, water in its liquid and gas forms, and air in its vapour form.

Fundamental terms

2.5 *Substances and phase change (cont.)*

Different substances have different melting and boiling points. Gold for example melts at 1064 °C, chocolate at 26 °C and most refrigerants melt at temperatures around -100 °C!

For a substance that is present in two of its phases at the same time - or undergoing a phase change - pressure and temperature become dependent. If the two phases exist in a closed container and the two phases are in thermal equilibrium the condition is said to be saturated. If the temperature of the two-phase mixture is increased the pressure in the container will also increase. The relationship between pressure and temperature for saturated conditions (liquid and

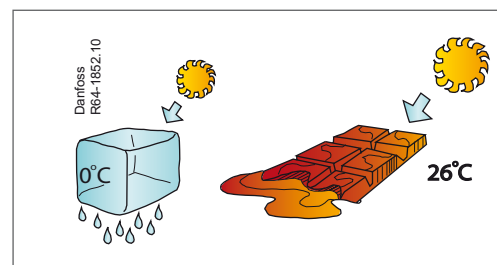

vapour) is typically called the vapour pressure curve. Using the vapour pressure curve one can determine what the pressure will be for an evaporating or condensing process.

2.6 *Latent heat*

Going back to the process of ice melting it is important to note that the amount of energy that must be transferred to 1 kg of ice in order to melt it is much higher than the energy needed to change the temperature of 1 kg of water by say 1 K. In section 2.4 the specific heat capacity of water was given as 4.187 kJ/kg K. The energy needed for melting 1 kg of ice is 335 kJ. The same amount of energy that can melt 1 kg of ice can increase the temperature of 1 kg of water by $(335 \text{ kJ} / 4.187 \text{ kJ/kg K}) = 80 \text{ K}$!

When looking at the boiling process of water the energy needed for evaporating 1 kg of water is 2501 kJ. The same amount of energy that can evaporate 1 kg of water can increase the temperature of not 1 but 6 kg of water by 100 K!

These examples show that energy transfer related to the transitional processes between phases is significant. That is also why ice has been used for cooling - it takes a lot of energy to melt the

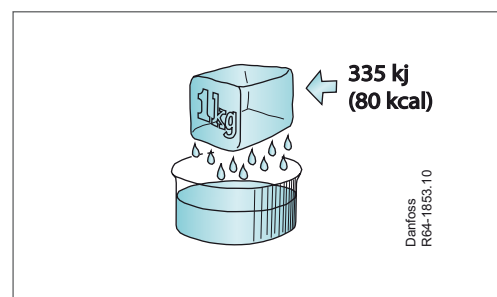

ice and while the ice melts the temperature stays at 0 °C.

The refrigerating effect in refrigeration systems is based on the use and control of the phase transition processes of evaporation. As the refrigerant evaporates it absorbs energy (heat) from its surroundings and by placing an object in thermal contact with the evaporating refrigerant it can be cooled to low temperature.

2.7 *Superheat*

Superheat is a very important term in the terminology of refrigeration - but it is unfortunately used in different ways. It can be used to describe a process where refrigerant vapour is heated from its saturated condition to a condition at higher temperature. The term superheat can also be used to describe - or quantify - the end condition of the before-mentioned process.

Superheat can be quantified as a temperature difference - between the temperature measured with a thermometer and the saturation temperature of the refrigerant measured with a pressure gauge. Therefore, superheat can not be deter-

mined from a single measurement of temperature alone - a measurement of pressure or saturation temperature is also needed. When superheat is quantified it should be quantified as a temperature difference and, consequently, be associated with the unit [K]. If quantified in [°C] it can be the cause of mistakes where the measured temperature is taken for the superheat or vice versa.

The evaporation process in a refrigeration system is one of the processes where the term superheat is used. This will be explained further in the next chapter.

Fundamental terms

2.8 Refrigerant diagrams

The characteristics of a refrigerant can be illustrated in a diagram using the primary properties as abscissa and ordinate. For refrigeration systems the primary properties are normally chosen as energy content and pressure. Energy content is represented by the thermodynamic property of specific enthalpy - quantifying the change in energy content per mass unit of the refrigerant as it undergoes processes in a refrigeration system. An example of a diagram based on specific enthalpy (abscissa) and pressure (ordinate) can be seen below. For a refrigerant the typically applicable interval for pressure is large - and therefore diagrams use a logarithmic scale for pressure.

The diagram is arranged so that it displays the liquid, vapour and mixture regions for the refrigerant. Liquid is found to the left (with a low energy content) - vapour to the right (with a high energy content).

In between you find the mixture region. The regions are bounded by a curve - called the saturation curve. The fundamental processes of evaporation and condensation are illustrated.

The idea of using a refrigerant diagram is that it makes it possible to represent the processes in the refrigeration system in such a way that analysis and evaluation of the process becomes easy. When using a diagram determining system operating conditions (temperatures and pressures) system refrigerating capacity can be found in a relatively simple and quick manner.

Diagrams are still used as the main tool for analysis of refrigeration processes. However, a number of PC programmes that can perform the same analysis faster and with more details have become generally available.

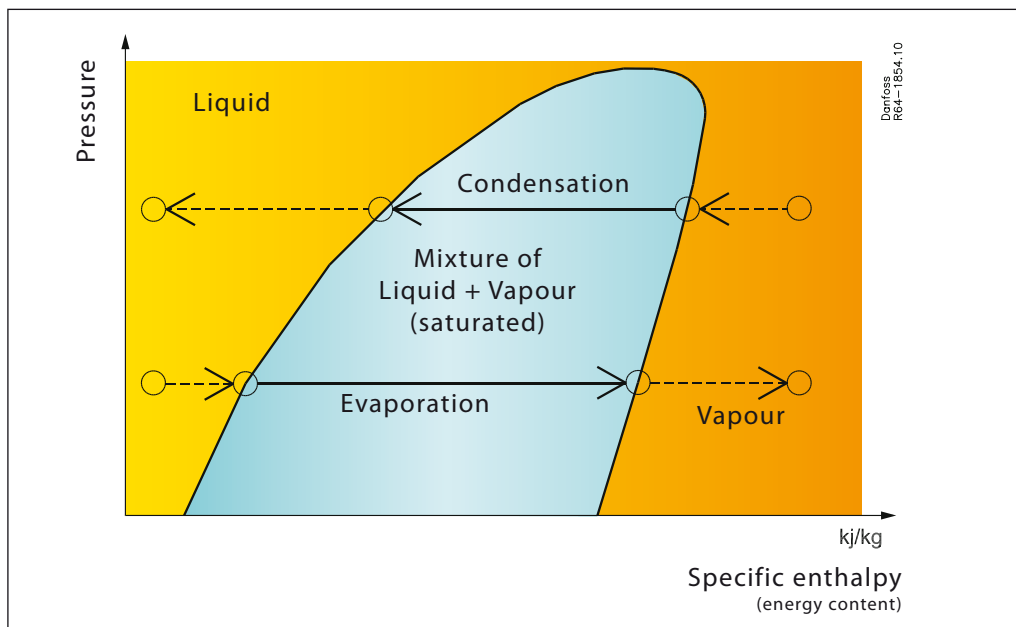

3. Refrigerant circuit

The physical terms for the refrigeration process have been dealt with previously, even though for practical reasons water is not used as a refrigerant.

A simple refrigerant circuit is built up as shown in the sketch below. In what follows, the individual components are described to clarify a final overall picture.

3.1 Evaporator

A refrigerant in liquid form will absorb heat when it evaporates and it is this conditional change that produces cooling in a refrigerating process. If a refrigerant at the same temperature as ambient is allowed to expand through a hose with an outlet to atmospheric pressure, heat will be taken up from the surrounding air and evaporation will occur at a temperature corresponding to atmospheric pressure.

If in a certain situation pressure on the outlet side (atmospheric pressure) is changed, a different temperature will be obtained since this is analogous to the original temperature - it is pressure-dependent.

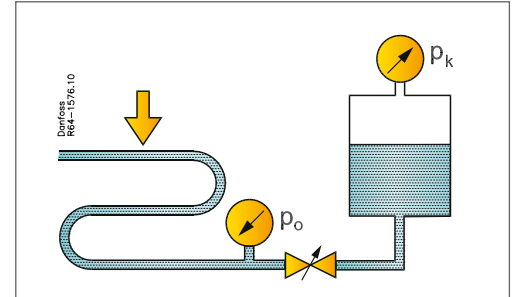

The component where this occurs is the evaporator, whose job it is to remove heat from the surroundings, i.e. to produce refrigeration.

3.2 Compressor

The refrigeration process is, as implied, a closed circuit. The refrigerant is not allowed to expand to free air.

When the refrigerant coming from the evaporator is fed to a tank the pressure in the tank will rise until it equals the pressure in the evaporator. Therefore, refrigerant flow will cease and the temperature in both tank and evaporator will gradually rise to ambient.

To maintain a lower pressure, and, with it a lower temperature it is necessary to remove vapour. This is done by the compressor, which sucks vapour away from the evaporator. In simple terms, the compressor can be compared to a pump that conveys vapour in the refrigeration circuit.

In a closed circuit a condition of equilibrium will always prevail. To illustrate this, if the compressor sucks vapour away faster than it can be formed in the evaporator the pressure will fall and with it the temperature in the evaporator. Conversely, if the load on the evaporator rises and the refrigerant evaporates quicker, the pressure and with it the temperature in the evaporator will rise.

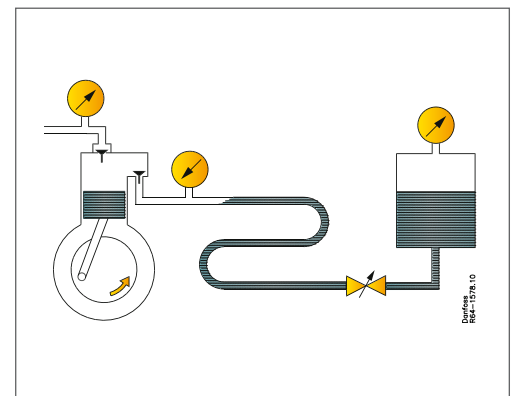
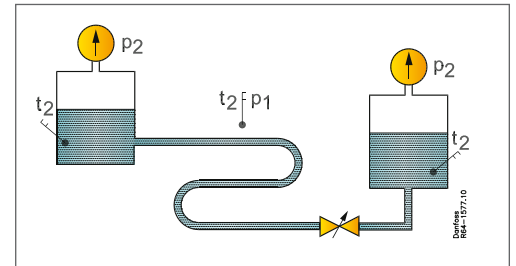

3.3 Compressor, method of operation

Refrigerant leaves the evaporator either as saturated or weak superheated vapour and enters the compressor where it becomes compressed. Compression is carried out as in a petrol engine, i.e. by the movement of a piston. The compressor requires energy and carries out work. This work is transferred to the refrigerant vapour and is called the compression input.

Because of the compression input, vapour leaves the compressor at a different pressure and the extra energy applied causes strong superheating of the vapour. Compression input is dependent on plant pressure and temperature. More work is of course

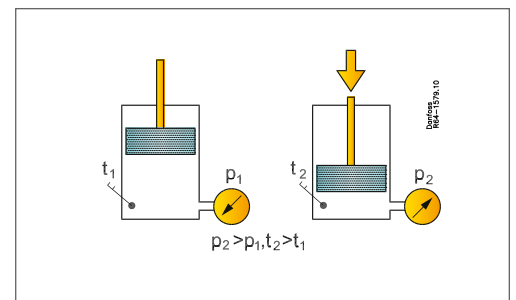

required to compress 1 kg vapour 10 bar than to compress the same amount 5 bar.

3.4 Condenser

The refrigerant gives off heat in the condenser, and this heat is transferred to a medium having a lower temperature. The amount of heat given off is the heat absorbed by the refrigerant in the evaporator plus the heat created by compression input.

The heat transfer medium can be air or water, the only requirement being that the temperature is lower than that which corresponds to the condensing pressure. The process in the condenser can otherwise be compared with the process in the evaporator except that it has the opposite "sign", i.e. the conditional change is from vapour to liquid.

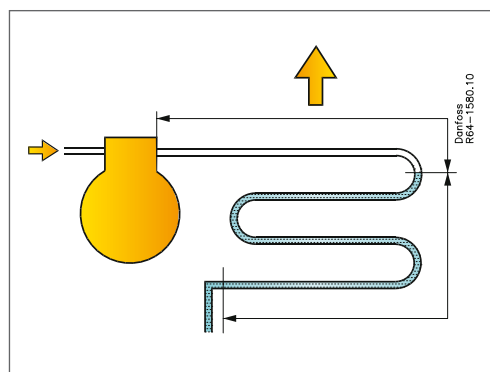

3.5 Expansion process

Liquid from the condenser runs to a collecting tank, the receiver. This can be likened to the tank mentioned under section 3.1 on the evaporator.

Pressure in the receiver is much higher than the pressure in the evaporator because of the compression (pressure increase) that has occurred in the compressor. To reduce pressure to the same level as the evaporating pressure a device must be inserted to carry out this process, which is called throttling, or expansion. Such a device is therefore known either as a throttling device or an expansion device. As a rule a valve is used - a throttle or expansion valve.

Ahead of the expansion valve the liquid will be a little under boiling point. By suddenly reducing pressure a conditional change will occur; the liq-

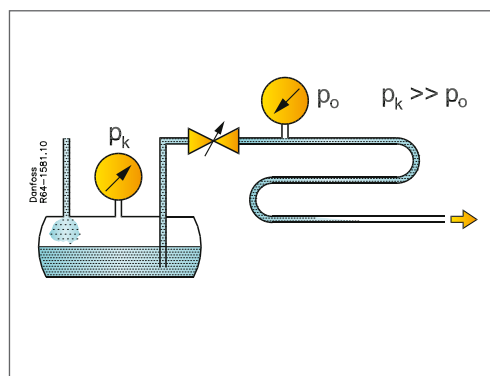

uid begins to boil and evaporate. This evaporation takes place in the evaporator and the circuit is thus complete.

3.6 High and low pressure sides of the refrigeration plant

There are many different temperatures involved in the operation of a refrigeration plant since there are such things as sub-cooled liquid, saturated liquid, saturated vapour and superheated vapour. There are however, in principle, only two pressures; evaporating pressure and condensing pressure. The plant then is divided into high pressure and low pressure sides, as shown in the sketch.

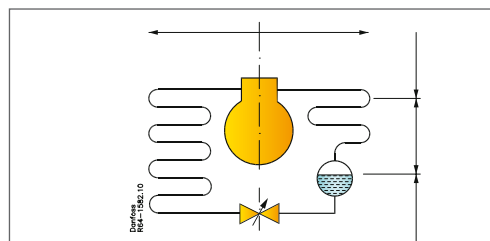

4. Refrigeration process, pressure/enthalpy diagram

The condensed refrigerant in the condenser is in condition A which lies on the line for the boiling point of the liquid. The liquid has thus a temperature t_c , a pressure p_c also called saturated temperature and pressure.

The condensed liquid in the condenser is further cooled down in the condenser to a lower temperature A^1 and now has a temperature t_i and an enthalpy h_0 . The liquid is now sub-cooled which means that it is cooled to a lower temperature than the saturated temperature.

The condensed liquid in the receiver is in condition A^1 which is sub-cooled liquid. This liquid temperature can change if the receiver and liquid is either heated or cooled by the ambient temperature. If the liquid is cooled the sub-cooling will increase and visa versa.

When the liquid passes through the expansion valve its condition will change from A^1 to B. This conditional change is brought about by the boiling liquid because of the drop in pressure to p_0 . At the same time a lower boiling point is produced, t_0 , because of the drop in pressure.

In the expansion valve the enthalpy is constant h_0 , as heat is neither applied nor removed.

At the evaporator inlet, point B, there is a mixture of liquid and vapour while in the evaporator at C there is saturated vapour. At the evaporator outlet

point C^1 there is super-heated vapour which means that the suction gas is heated to a higher temperature than the saturated temperature. Pressure and temperature are the same at point B and at outlet point C^1 where the gas is super-heated the evaporator has absorbed heat from the surroundings and the enthalpy has changed to h_1 .

When the refrigerant passes through the compressor its condition changes from C^1 to D. Pressure rises to condensing pressure p_c . The temperature rises to $t_{hot-gas}$ which is higher than the condensing temperature t_c because the vapour has been strongly superheated. More energy (from the electrical motor) in the form of heat has also been introduced and the enthalpy therefore changes to h_2 .

At the condenser inlet, point D, the condition is thus one of superheated vapour at pressure p_c . Heat is given off from the condenser to the surroundings so that the enthalpy again changes to main point A^1 . First in the condenser there occurs a conditional change from strongly superheated vapour to saturated vapour (point E), then a condensation of the saturated vapour. From point E to point A the temperature (condensing temperature) remains the same, in that condensation and evaporation occurs at constant temperature. From point A to point A^1 in the condenser the condensed liquid is further cooled down, but the pressure remains the same and the liquid is now sub-cooled.

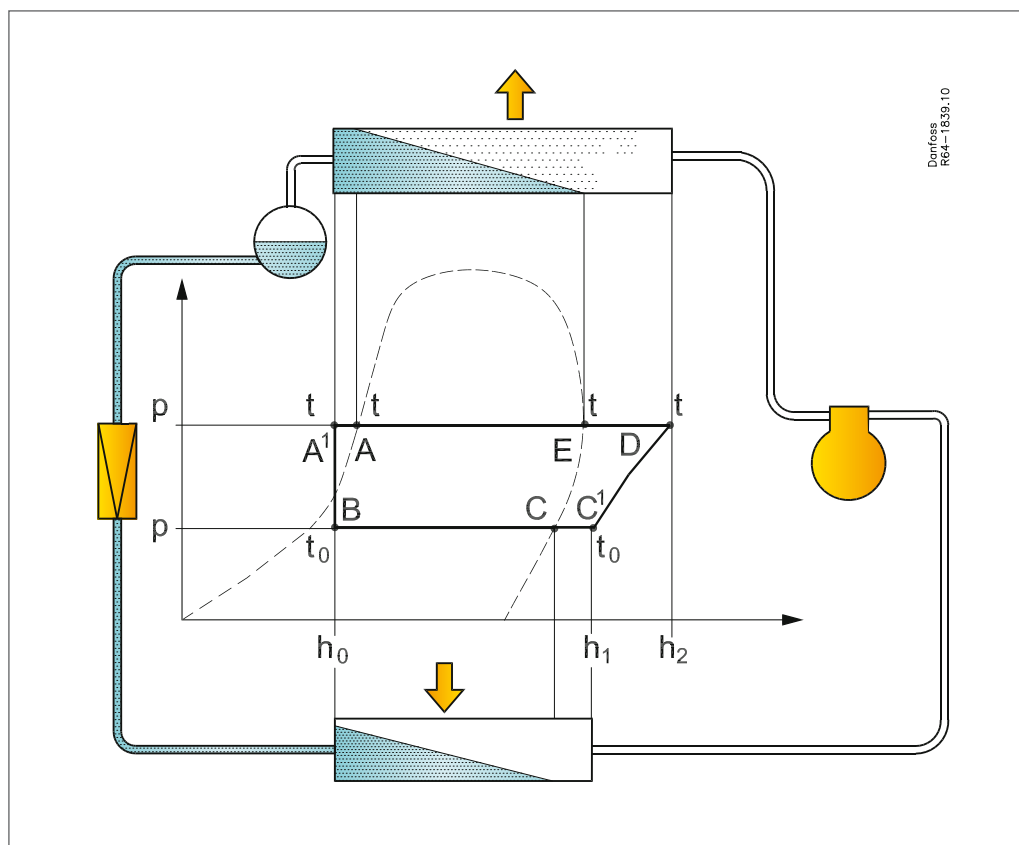

t_c = condensing temperature
 p_c = condensing pressure
 t_i = liquid temperature
 t_0 = evaporating temperature
 p_0 = evaporating pressure

5. Refrigerants

5.1 General requirements

During the examination of the refrigeration process the question of refrigerants was not discussed since it was not necessary to do so in connection with the basic physical principles of the conditional change of substances. It is well known, however, that in practice different refrigerants are used according to the specific application and requirements. The most important factors are as follows:

- The refrigerant ought not to be poisonous. Where this is impossible, the refrigerant must have a characteristic smell or must contain a tracer so that leakage can quickly be observed.
- The refrigerant ought not to be flammable nor explosive. Where this condition cannot be met the same precautions as in the first point must be observed and local legislations must be followed.
- The refrigerant ought to have reasonable pressure, preferably a little higher than atmospheric pressure at the temperatures required to be held in the evaporator.
- To avoid heavy refrigerator design the pressure, which corresponds to normal condensing pressure, must not be too high.
- Relatively high evaporating temperature is required so that heat transmission can occur with least possible circulating refrigerant.
- Refrigerant vapour ought not to have too high a specific volume because this is a determinant for compressor stroke at a particular cold yield.
- The refrigerant must be chemically stable at the temperatures and pressures normal in a refrigeration plant.
- The refrigerant ought not to be corrosive and must not, either in liquid or vapour form, attack normal design materials.
- The refrigerant must not break down lubricating oil.
- The refrigerant must be easy to obtain and handle.
- The refrigerant must not cost too much.

5.2 Fluorinated refrigerants

Fluorinated refrigerants always carry the designation "R" followed by a number, e.g. R22, R134a, R404A and R407C. Sometimes they are met bearing their trade names. The fluorinated refrigerants all have the following features:

- Vapour is smell-free and non-irritant.
- Extensively non-poisonous. In the presence of fire the vapour can give off fluoric acid and phosgene, which are very poisonous.
- Non-corrosive.
- Non-flammable and non-explosive.

The most common fluorinated refrigerants are:

R134a, which is a substance of the ethane group with the formula CH_2FCF_3 and has a normal boiling point of $-26.1\text{ }^\circ\text{C}$. Its thermodynamic properties make it suitable as a refrigerant for medium temperature applications such as domestic refrigerators.

R22, which is a substance of the methane group with the formula CHF_2Cl and has a boiling point of $-40.8\text{ }^\circ\text{C}$. Its thermodynamic properties make it suitable as a refrigerant for a wide range of applications in commercial refrigeration and air conditioning. R22 is being phased out as refrigerant in many countries due to its ozone depleting potential.

R404A/R507A (also known as R507), which is a mixture of the refrigerants R125 (CHF_2CF_3) and

R143a (CH_3CF_3) with a boiling point at $(-46.7\text{ }^\circ\text{C})$ which is slightly lower than for R22. Its thermodynamic properties makes it suitable as a refrigerant for low and medium temperature applications in commercial refrigeration (e.g. supermarkets).

R407C, which is a mixture of the refrigerants R32 (CH_2F_2), R125 (CHF_2CF_3) and R134a (CH_2FCF_3) with a boiling point at $(-43.6\text{ }^\circ\text{C})$ which is slightly lower than for R22. Its thermodynamic properties make it suitable as a refrigerant for medium and high temperature applications in residential and commercial air conditioning.

R410A, which is a mixture of the refrigerants R32 (CH_2F_2) and R125 (CHF_2CF_3) with a boiling point at $(-51.4\text{ }^\circ\text{C})$ which is lower than for R22. Its thermodynamic properties make it suitable as a refrigerant for medium and high temperature applications in residential and commercial air conditioning.

Apart from these fluorinated refrigerants there is a long series of others not seen very often today: R23, R123, R124 and R218.

Except for R22, systems with fluorinated hydrocarbons are in general lubricated with polyol ester oils (POE). These oil types are much more sensitive to react chemically with water, the so-called "hydrolysis" reaction. For that reason systems today are kept extremely dry with filter driers.

5.3 Ammonia NH_3

Ammonia NH_3 is used extensively in large industrial refrigeration plants. Its normal boiling point is $-33\text{ }^\circ\text{C}$. Ammonia has a characteristic smell even in very small concentrations in air. It cannot

burn, but it is moderately explosive when mixed with air in a volume percentage of 13 to 28%. Because of corrosion, copper or copper alloys must not be used in ammonia plants.

5.4 Secondary refrigerants

The refrigerants mentioned above are often designated "primary refrigerants". As an intermediate link in heat transmission from the surround-

ings to the evaporator, the so-called "secondary refrigerants" can be used, e.g. water, brine, atmospheric air etc.

6. Refrigeration plant main components

6.1 Compressor

The job of the compressor is to suck vapour from the evaporator and force it into the condenser. The most common type is the piston compressor, but other types have won acceptance, e.g. centrifugal scroll and screw compressors.

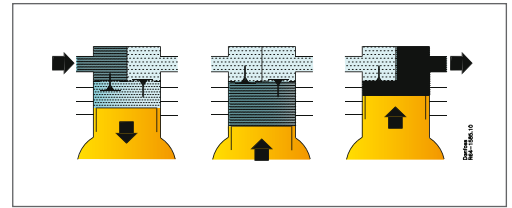

The piston compressor covers a very large capacity range, right from small single cylinder models for household refrigerators up to 8 to 12 cylinder models with a large swept volume for industrial applications.

In the smallest applications the hermetic compressor is used, where compressor and motor are built together as a complete hermetic unit.

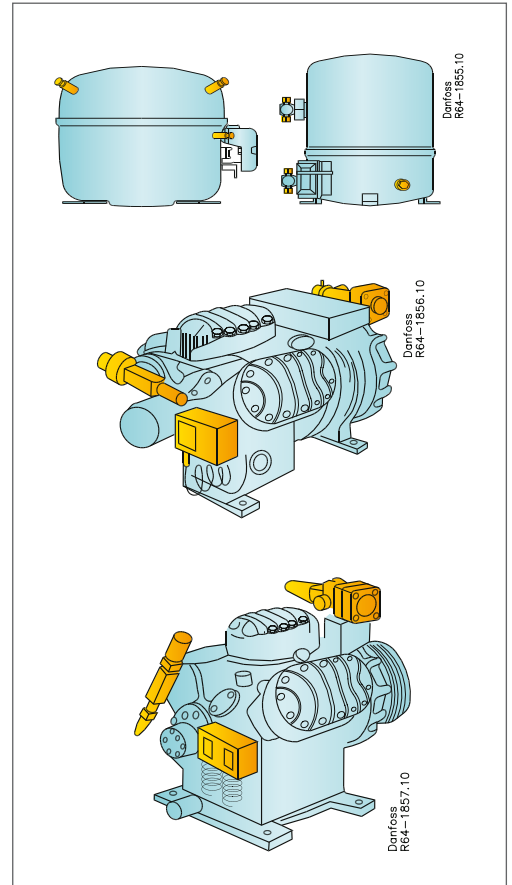

For medium sized plants one of the most common compressors is the larger sizes of hermetic compressors in either piston or scroll versions. The applications are both air conditioning, general commercial refrigeration and chillers.

For larger plants the most common is the semi-hermetic compressor. The advantage here is that shaft glands can be avoided; these are very difficult to replace when they begin to leak. However, the design cannot be used on ammonia plants since this refrigerant attacks motor windings.

Still larger HFC compressors, and all ammonia compressors, are designed as "open" compressors, i.e. with the motor outside the crankcase. Power transmission can be direct to the crankshaft or through a V-belt drive.

For quite special applications there is the oil-free compressor. But lubrication of bearings and cylinder walls with oil is normally always necessary. On large refrigeration compressors oil is circulated by an oil pump.

6.2 Condenser

The purpose of the condenser is to remove the amount of heat that is equal to the sum of the heat absorbed in the evaporator and the heat produced by compression. There are many different kinds of condenser.

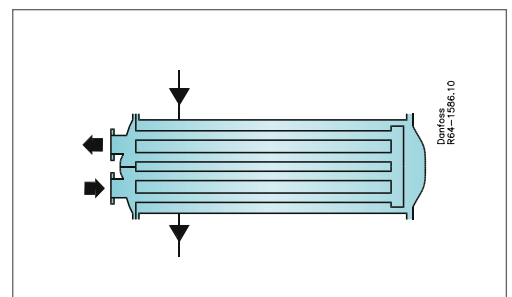

Shell and tube condenser. This type of condenser is used in applications where sufficient cooling water is available. It consists of a horizontal cylinder with welded-on flat end caps, which support the cooling tubes. End covers are bolted to the end plates.

The refrigerant condensate flows through the cylinder, the cooling water through the tubes. The end covers are divided into sections by ribs. The sections act as reversing chambers for the

water so that it circulates several times through the condenser. As a rule, the water becomes heated 5-10 °C when it has passed through a condenser.

Refrigeration plant main components

6.2 Condenser (cont.)

If it is desirable or necessary to cut down on the amount of water an *evaporating condenser* can be used instead. This type of condenser consists of a housing in which there is a condensing coil, water distribution tubes, deflection plates and fans.

Water distribution tubes with nozzles are placed over the condensing coil so that water is spread over and runs down the coil. The fans direct a strong flow of air across the condensing coil. When the falling drops of water meet the upward air flow some of the water will evaporate. This absorbs the necessary evaporating heat from the refrigerant vapour and causes it to condense.

The warm refrigerant vapour is led to the top of the condensing coil after which it condenses and runs from the bottom of the coil as liquid.

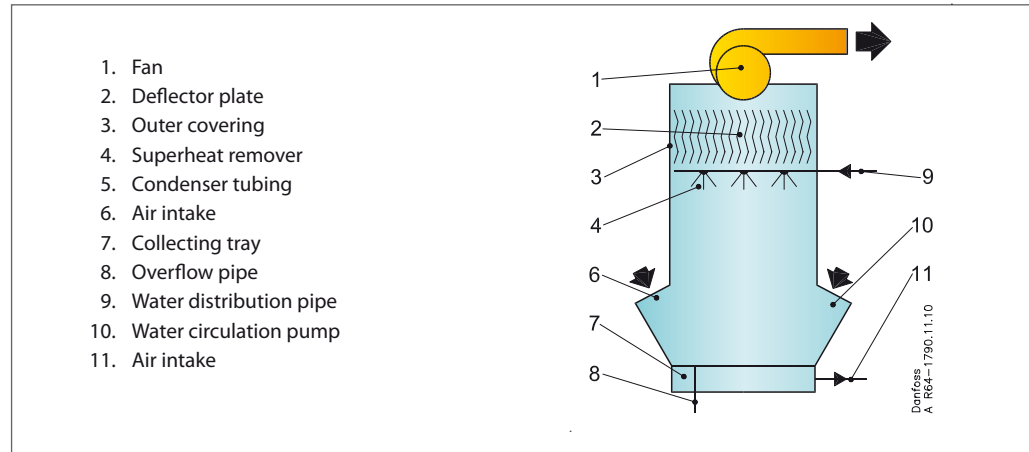

The principal involving water evaporation is also used in connection with *cooling towers*. These are installed when the most practical is to place a shell and tube condenser near a compressor. The water is then circulated in a circuit between condenser and cooling tower.

but instead of condensing elements there are deflector plates. Air is heated on its way through the tower by direct contact with the trickle of water travelling downwards and is, therefore, able to absorb an increasing amount of moisture coming from part-evaporation. In this way, the cooling water loses heat. Water loss is made up by supplying more water.

In principle, the cooling tower is built up the same as the evaporating condenser,

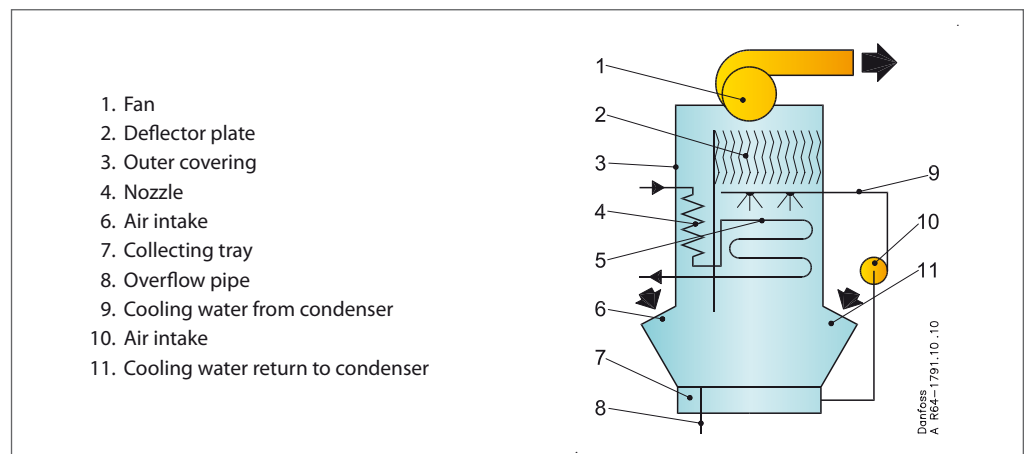

Refrigeration plant main components

6.2 Condenser (cont.)

It is possible to save 90-95% water consumption by using evaporating condensers or cooling towers, when compared to the water consumption of shell and tube condensers.

For one reason or another it is not always possible to use water for the condensing process. In such cases an *air-cooled condenser* must be used. Since air has poor heat transfer characteristics, compared with water, a large surface on the outside of the condensing tubes is necessary. This is achieved using large ribs or fins and, in addition, by ensuring generous air circulation mechanically.

This is the normal condenser for commercial refrigeration.

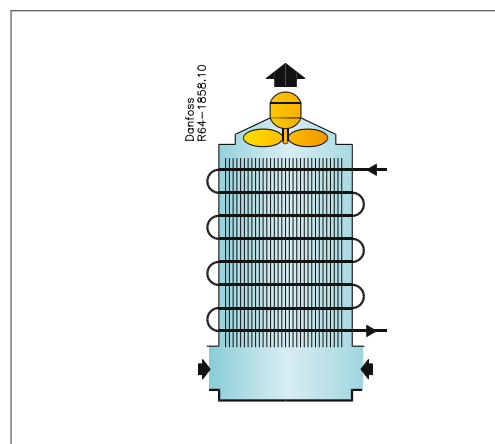

6.3 Expansion valve

The main purpose of the expansion valve is to ensure a sufficient pressure differential between the high and low pressure sides of the plant. The simplest way of doing this is to use a capillary tube inserted between the condenser and evaporator.

The capillary tube is, however, only used in small, simple appliances like refrigerators because it is not capable of regulating the amount of liquid that is injected into the evaporator.

A regulating valve must be used for this process, the most usual being the thermostatic expansion valve, which consists of a valve housing, capillary tube and a bulb. The valve housing is fitted in the liquid line and the bulb is fitted on the evaporator outlet.

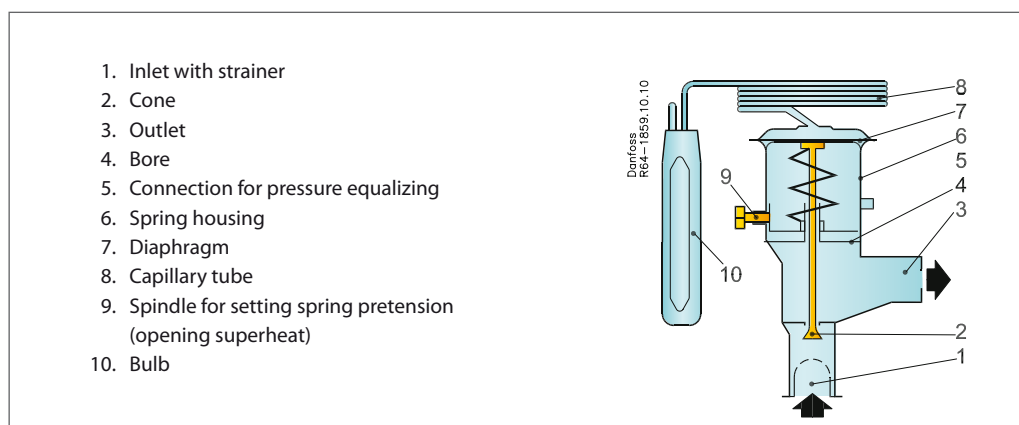

This figure shows an evaporator fed by a thermostatic expansion valve. A small amount of liquid is contained in a part of the bulb. The rest of the bulb, the capillary tube and the space above the diaphragm in the valve housing is charged with saturated vapour at a pressure corresponding to the temperature at the bulb. The space under the diaphragm is in connection with the evaporator and the pressure is therefore equal to the evaporating pressure.

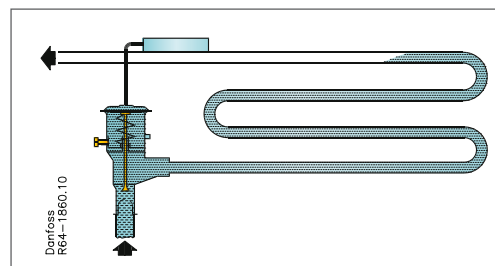

Refrigeration plant main components

6.3 Expansion valve (cont.)

The degree of opening of the valve is determined by:

- The pressure produced by the bulb temperature acting on the top surface of the diaphragm.
- The pressure under the diaphragm, which is equal to the evaporating pressure.
- The pressure of the spring acting on the underside of the diaphragm.

During normal operation, evaporation will cease some distance up in the evaporator.

Then, saturated gas appears which becomes superheated on its way through the last part of the evaporator. The bulb temperature will thus be evaporating temperature plus superheat, e.g. at

-10 °C evaporating temperature the bulb temperature could be 0 °C.

If the evaporator receives too little refrigerant the vapour will be further superheated and the temperature at the outlet pipe will rise. The bulb temperature will then also rise and with it the vapour pressure in the bulb element since more of the charge will evaporate. Because of the rise in pressure the diaphragm becomes forced down, the valve opens and more liquid is supplied to the evaporator. Correspondingly, the valve will close more if the bulb temperature becomes lower.

Thermostatic expansion valves are produced in several versions and of course there are many variants within each type.

6.4 Evaporation systems

Depending on the application, various requirements are imposed on the evaporator. Evaporators are therefore made in a series of different versions.

Evaporators for natural air circulation are used less and less because of the relatively poor heat transfer from the air to the cooling tubes. Earlier versions were fitted with plain tubes, but now it is common to use ribbed tubes or finned elements.

Evaporator performance is increased significantly if forced air circulation is used. With an increase of air velocity the heat transfer from air to tube is improved so that for a given cold yield a smaller evaporator surface than for natural circulation can be used.

As the name implies, a chiller cools down liquid. The simplest method is to immerse a coil of tube in an open tank. Closed systems are coming into use more and more. Here, tube coolers made similar to shell and tube condensers are employed.

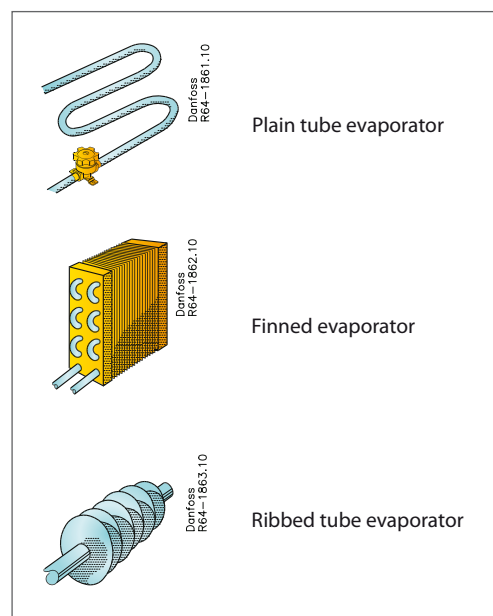

7. The practical build-up of a refrigeration plant

Figure A shows the principle build-up of a refrigeration plant for a simple cold store - much like those that can be seen in butchers' shops and supermarkets.

The compressor unit can, for example, be installed in an adjacent storage room with an outlet to fresh air. Such a unit consists of a compressor driven by V-belt and electric motor. Additionally, the base frame carries an air-cooled condenser and a receiver. A fan is mounted on the shaft of the electric motor to force air through the condenser and ensure the necessary degree of cooling. The line between compressor and condenser is known as the discharge line.

From the receiver, an uninsulated line, the liquid line, is taken out to the cold store where it is connected to the thermostatic expansion valve at the evaporator inlet. The evaporator is built up with close-pitch fins attached to tubes. It is also equipped with a fan for forced air circulation and a drip tray.

From the outlet side of the evaporator a line, the suction line, is led back to the compressor. The diameter of the suction line is somewhat larger than the liquid line because it carries vapour. For this reason the suction line is as a rule insulated.

Today the majority of compressors used are of the semi-hermetic and hermetic types.

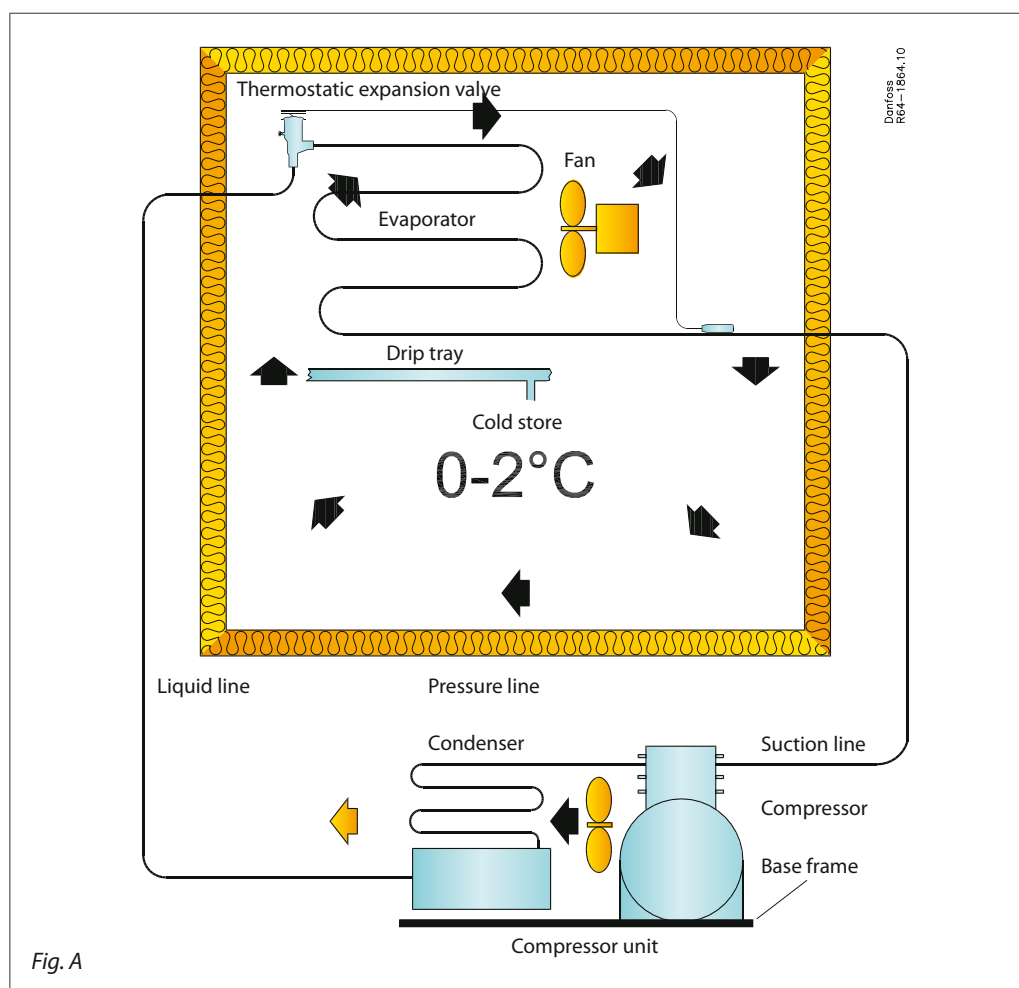

The practical build-up of a refrigeration plant

Figure B gives details of momentary temperatures in a refrigeration plant. At the compressor outlet the pressure is 7.6 bar and the temperature is 60 °C because of the presence of superheated gas. The temperature in the upper part of the condenser will quickly fall to saturation temperature, which at the pressure concerned will be 34 °C, because superheat is removed and condensation begins.

Pressure at the receiver outlet will remain more or less the same, while subcooling of the liquid begins because the temperature has fallen by 2 °C to 32 °C.

In the evaporator a pressure of 1 bar and an evaporating temperature of -10 °C are indicated. In the last part of the evaporator the vapour becomes superheated so the temperature at the thermo-

static expansion valve bulb becomes +2 °C, corresponding to the superheat set on the valve.

As illustrated below, air temperature will vary, in that the air will take up heat on its way round the store from products, walls, ceiling, etc. The temperature of the air blown across the condenser will also vary with the time of year.

A refrigeration plant must then be dimensioned according to the largest load it will be subjected to. To be able to accommodate smaller loads, facilities must exist in the plant for altering yield. The process of making such alterations is called regulation and it is precisely regulation that Danfoss' automatic controls are made for. But that is a subject, which is outside the scope of this publication.

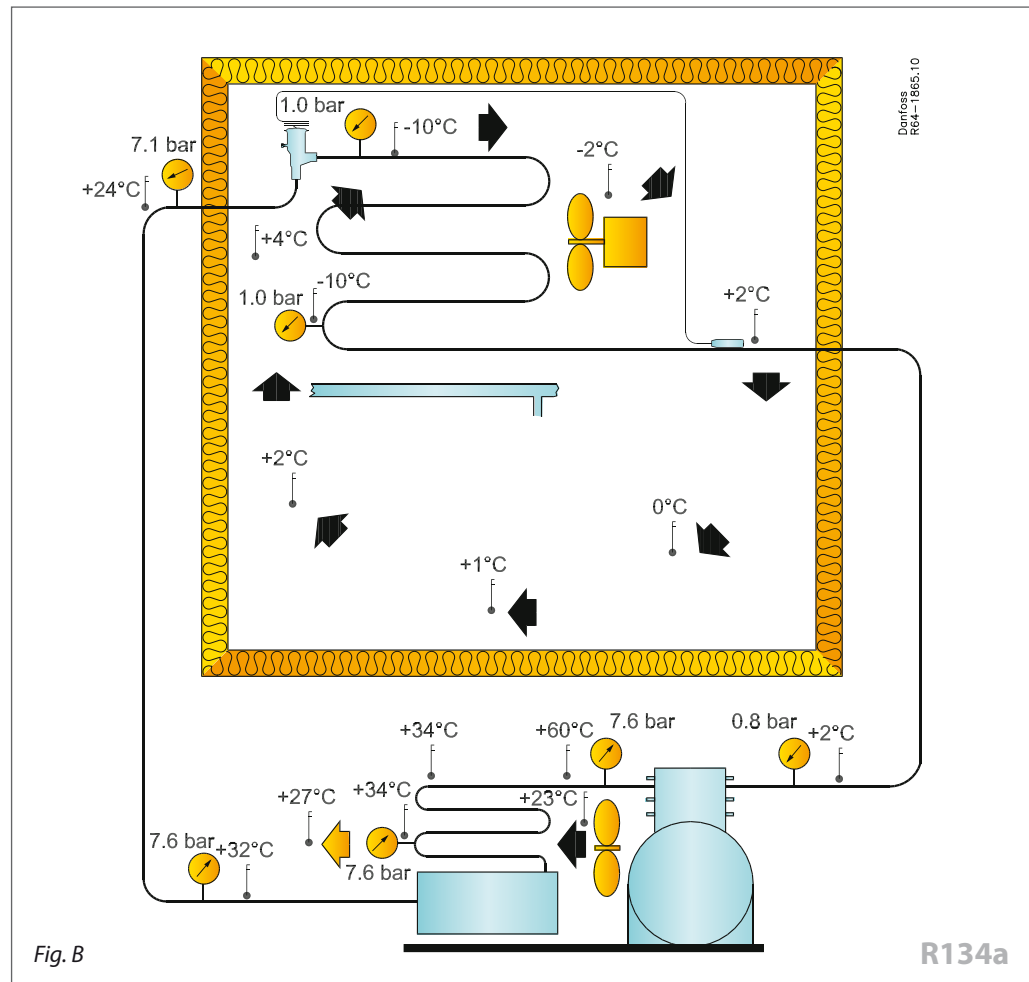

Notes

A large grid of graph paper for taking notes, consisting of 20 columns and 30 rows of small squares.

The Danfoss product range for the refrigeration and air conditioning industry

Danfoss Refrigeration & Air Conditioning is a worldwide manufacturer with a leading position in industrial, commercial and supermarket refrigeration as well as air conditioning and climate solutions.

We focus on our core business of making quality products, components and systems that enhance performance and reduce total life cycle costs – the key to major savings.



Controls for Commercial Refrigeration



Controls for Industrial Refrigeration



Electronic Controls & Sensors



Industrial Automation



Household Compressors



Commercial Compressors



Sub-Assemblies



Thermostats



Brazed plate heat exchanger

We are offering a single source for one of the widest ranges of innovative refrigeration and air conditioning components and systems in the world. And, we back technical solutions with business solution to help your company reduce costs, streamline processes and achieve your business goals.

Danfoss A/S • www.danfoss.com