

SKM400GB17E4



SEMITRANS® 3

IGBT4 Modules

SKM400GB17E4

Features*

- IGBT4 = 4th generation medium fast trench IGBT (Infineon)
- CAL4 = Soft switching 4th generation CAL-Diode
- Insulated copper baseplate using DBC Technology (Direct Copper Bonding)
- With integrated Gate resistor
- For switching frequencies up to 8kHz
- UL recognized, file no. E63532

Typical Applications

- AC inverter drives
- UPS
- Electronic welders
- Public transport
- Wind power

Remarks

- Case temperature limited to $T_C = 125^\circ\text{C}$ max.
- Recommended $T_{j,op} = -40 \dots +150^\circ\text{C}$
- Product reliability results valid for $T_j = 150^\circ\text{C}$

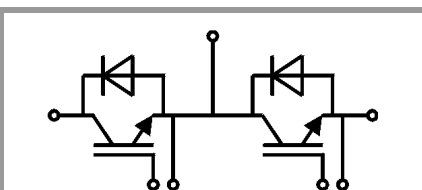

GB

Absolute Maximum Ratings				
Symbol	Conditions	Values	Unit	
IGBT				
V_{CES}	$T_j = 25^\circ\text{C}$	1700	V	
I_C	$T_j = 175^\circ\text{C}$	$T_c = 25^\circ\text{C}$	614	A
		$T_c = 80^\circ\text{C}$	474	A
I_{Cnom}		400	A	
I_{CRM}		1200	A	
V_{GES}		-20 ... 20	V	
t_{psc}	$V_{CC} = 1000\text{ V}$ $V_{GE} \leq 15\text{ V}$ $V_{CES} \leq 1700\text{ V}$	$T_j = 150^\circ\text{C}$	10	μs
T_j		-40 ... 175	$^\circ\text{C}$	
Inverse diode				
V_{RRM}	$T_j = 25^\circ\text{C}$	1700	V	
I_F	$T_j = 175^\circ\text{C}$	$T_c = 25^\circ\text{C}$	443	A
		$T_c = 80^\circ\text{C}$	327	A
I_{FRM}		800	A	
I_{FSM}	$t_p = 10\text{ ms, sin } 180^\circ, T_j = 25^\circ\text{C}$	2340	A	
T_j		-40 ... 175	$^\circ\text{C}$	
Module				
$I_{t(RMS)}$		500	A	
T_{stg}	module without TIM	-40 ... 125	$^\circ\text{C}$	
V_{isol}	AC sinus 50 Hz, $t = 1\text{ min}$	4000	V	

Characteristics					
Symbol	Conditions	min.	typ.	max.	Unit
IGBT					
$V_{CE(sat)}$	$I_C = 400\text{ A}$ $V_{GE} = 15\text{ V}$ chipelevel	$T_j = 25^\circ\text{C}$	1.92	2.20	V
		$T_j = 150^\circ\text{C}$	2.30	2.60	V
V_{CE0}	chipelevel	$T_j = 25^\circ\text{C}$	0.80	0.90	V
		$T_j = 150^\circ\text{C}$	0.70	0.80	V
r_{CE}	$V_{GE} = 15\text{ V}$ chipelevel	$T_j = 25^\circ\text{C}$	2.8	3.3	$\text{m}\Omega$
		$T_j = 150^\circ\text{C}$	4.0	4.5	$\text{m}\Omega$
$V_{GE(th)}$	$V_{GE} = V_{CE}, I_C = 16\text{ mA}$	5.2	5.8	6.4	V
I_{CES}	$V_{GE} = 0\text{ V}, V_{CE} = 1700\text{ V}, T_j = 25^\circ\text{C}$			5	mA
C_{ies}	$V_{CE} = 25\text{ V}$ $V_{GE} = 0\text{ V}$	$f = 1\text{ MHz}$	32.0		nF
C_{oes}		$f = 1\text{ MHz}$	1.36		nF
C_{res}		$f = 1\text{ MHz}$	1.16		nF
Q_G	$V_{GE} = -8\text{ V} \dots +15\text{ V}$		3200		nC
R_{Gint}	$T_j = 25^\circ\text{C}$		1.9		Ω
$t_{d(on)}$	$V_{CC} = 1200\text{ V}$ $I_C = 400\text{ A}$	$T_j = 150^\circ\text{C}$	280		ns
t_r	$V_{GE} = +15/-15\text{ V}$	$T_j = 150^\circ\text{C}$	45		ns
E_{on}	$R_{Gon} = 2\ \Omega$	$T_j = 150^\circ\text{C}$	157		mJ
$t_{d(off)}$	$R_{Goff} = 1\ \Omega$	$T_j = 150^\circ\text{C}$	760		ns
t_f	$di/dt_{on} = 10000\text{ A}/\mu\text{s}$	$T_j = 150^\circ\text{C}$	140		ns
E_{off}	$di/dt_{off} = 2300\text{ A}/\mu\text{s}$ $dv/dt = 5600\text{ V}/\mu\text{s}$	$T_j = 150^\circ\text{C}$	180		mJ
$R_{th(j-c)}$	per IGBT			0.066	K/W
$R_{th(c-s)}$	per IGBT, P12 (reference)		0.036		K/W
$R_{th(c-s)}$	per IGBT, HP-PCM		0.019		K/W



SEMITRANS® 3

IGBT4 Modules

SKM400GB17E4

Features*

- IGBT4 = 4th generation medium fast trench IGBT (Infineon)
- CAL4 = Soft switching 4th generation CAL-Diode
- Insulated copper baseplate using DBC Technology (Direct Copper Bonding)
- With integrated Gate resistor
- For switching frequencies up to 8kHz
- UL recognized, file no. E63532

Typical Applications

- AC inverter drives
- UPS
- Electronic welders
- Public transport
- Wind power

Remarks

- Case temperature limited to $T_C = 125^\circ\text{C}$ max.
- Recommended $T_{j,op} = -40 \dots +150^\circ\text{C}$
- Product reliability results valid for $T_j = 150^\circ\text{C}$

Characteristics						
Symbol	Conditions		min.	typ.	max.	Unit
Inverse diode						
$V_F = V_{EC}$	$I_F = 400\text{ A}$ $V_{GE} = 0\text{ V}$ chipelevel	$T_j = 25^\circ\text{C}$		2.00	2.40	V
		$T_j = 150^\circ\text{C}$		2.16	2.57	V
V_{F0}	chipelevel	$T_j = 25^\circ\text{C}$		1.32	1.56	V
		$T_j = 150^\circ\text{C}$		1.08	1.22	V
r_F	chipelevel	$T_j = 25^\circ\text{C}$		1.71	2.1	m Ω
		$T_j = 150^\circ\text{C}$		2.7	3.4	m Ω
I_{RRM}	$I_F = 400\text{ A}$	$T_j = 150^\circ\text{C}$		615		A
Q_{rr}	$di/dt_{off} = 10100\text{ A}/\mu\text{s}$	$T_j = 150^\circ\text{C}$		150		μC
E_{rr}	$V_{GE} = -15\text{ V}$ $V_{CC} = 1200\text{ V}$	$T_j = 150^\circ\text{C}$		130		mJ
$R_{th(j-c)}$	per diode				0.13	K/W
$R_{th(c-s)}$	per diode, P12 (reference)			0.044		K/W
$R_{th(c-s)}$	per diode, HP-PCM			0.027		K/W
Module						
L_{CE}				15		nH
$R_{CC'+EE'}$	measured per switch	$T_C = 25^\circ\text{C}$		0.55		m Ω
		$T_C = 125^\circ\text{C}$		0.85		m Ω
$R_{th(c-s)1}$	calculated without thermal coupling, P12 (reference)			0.0099		K/W
$R_{th(c-s)2}$	including thermal coupling, T_s underneath module, P12 (reference)			0.016		K/W
$R_{th(c-s)2}$	including thermal coupling, T_s underneath module, HP-PCM			0.0088		K/W
M_s	to heat sink M6		3		5	Nm
M_t	to terminals M6		2.5		5	Nm
					-	
w					325	g

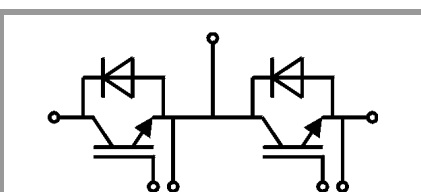

GB

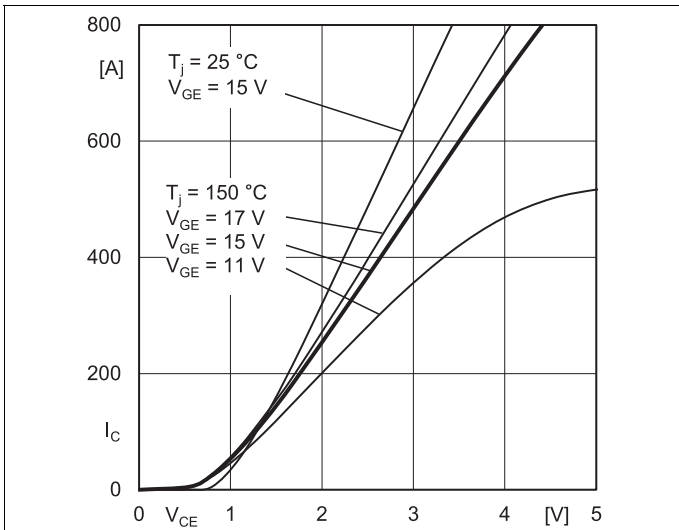

Fig. 1: Typ. output characteristic, inclusive R_{CC+EE}

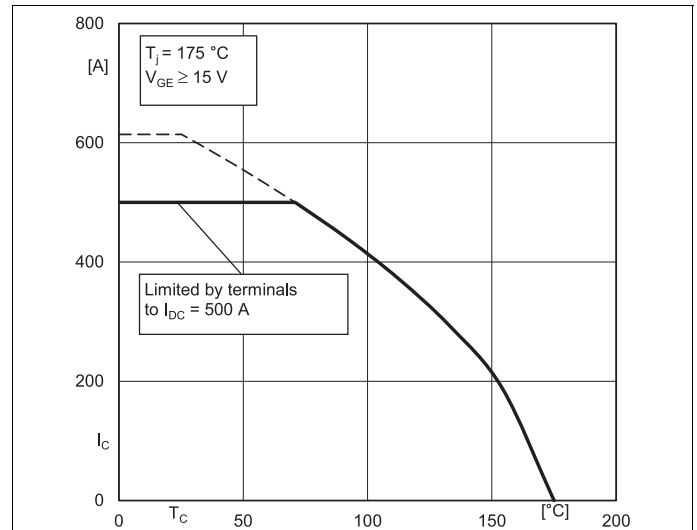

Fig. 2: Rated current vs. temperature $I_C = f(T_C)$

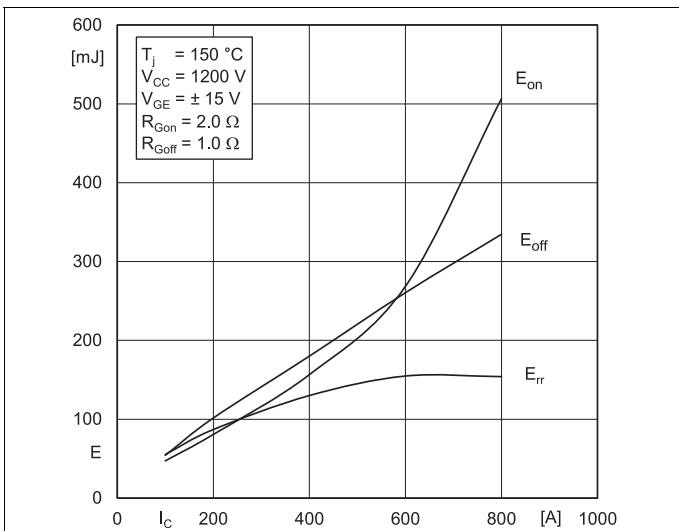

Fig. 3: Typ. turn-on /-off energy = $f(I_C)$

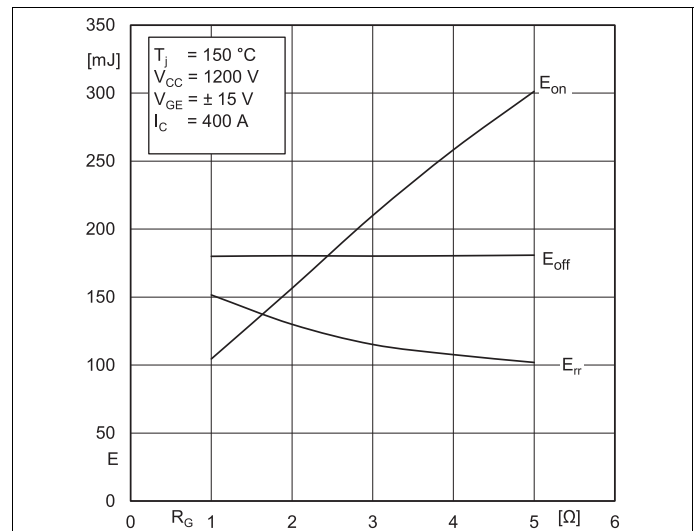

Fig. 4: Typ. turn-on /-off energy = $f(R_G)$

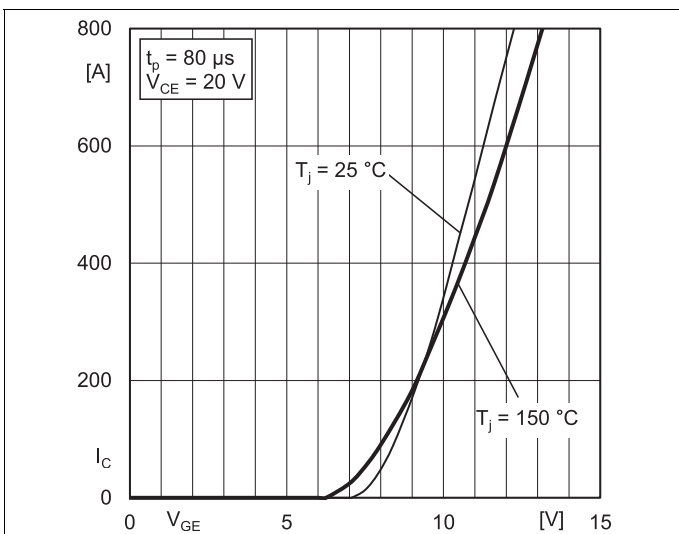

Fig. 5: Typ. transfer characteristic

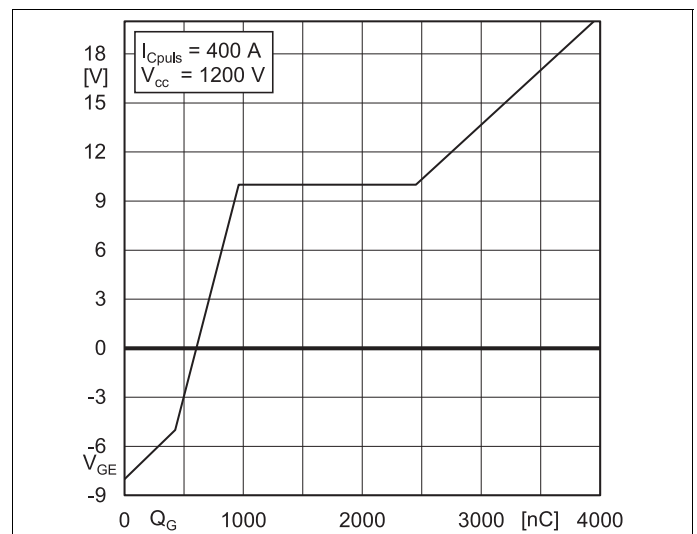

Fig. 6: Typ. gate charge characteristic

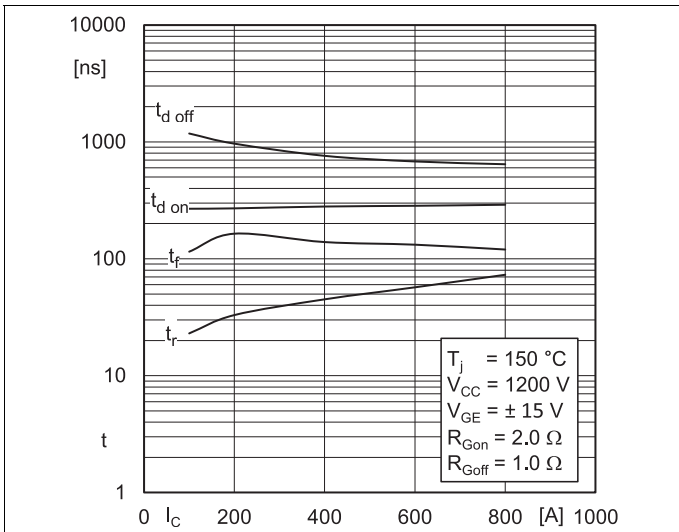

Fig. 7: Typ. switching times vs. I_C

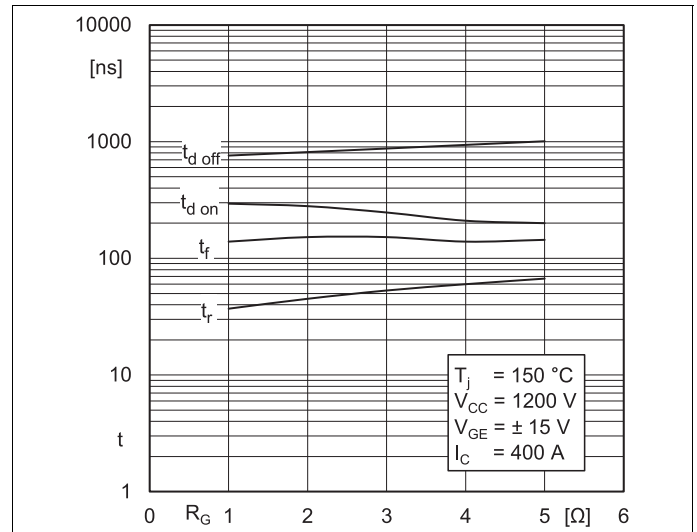

Fig. 8: Typ. switching times vs. gate resistor R_G

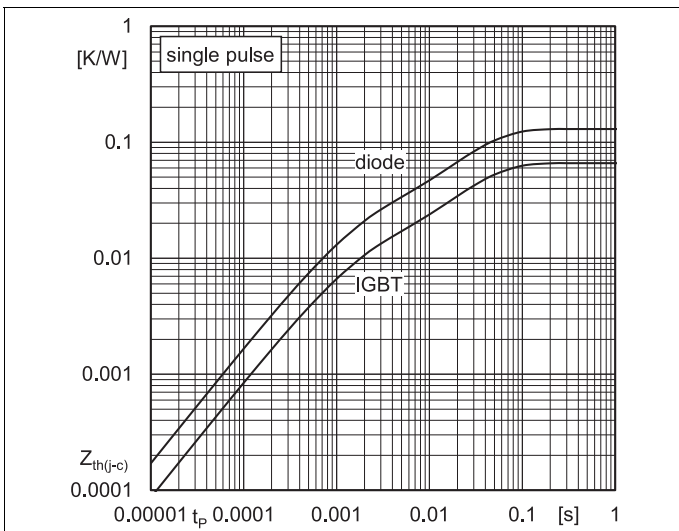

Fig. 9: Transient thermal impedance

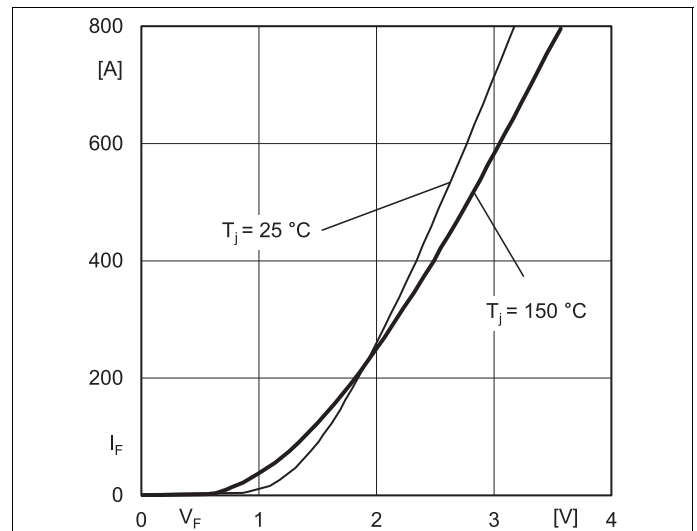

Fig. 10: Typ. CAL diode forward charact., incl. $R_{CC+EE'}$

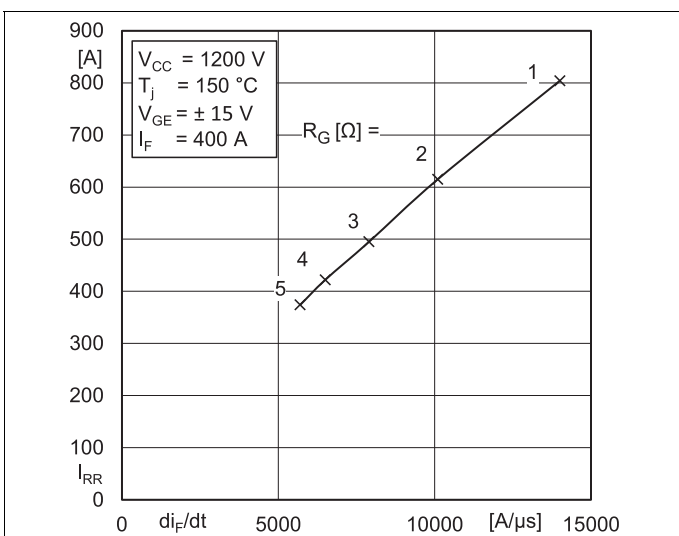

Fig. 11: Typ. CAL diode peak reverse recovery current

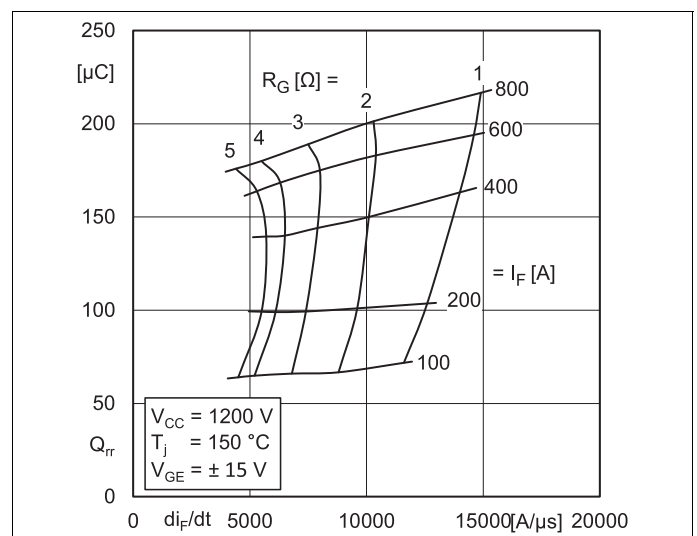
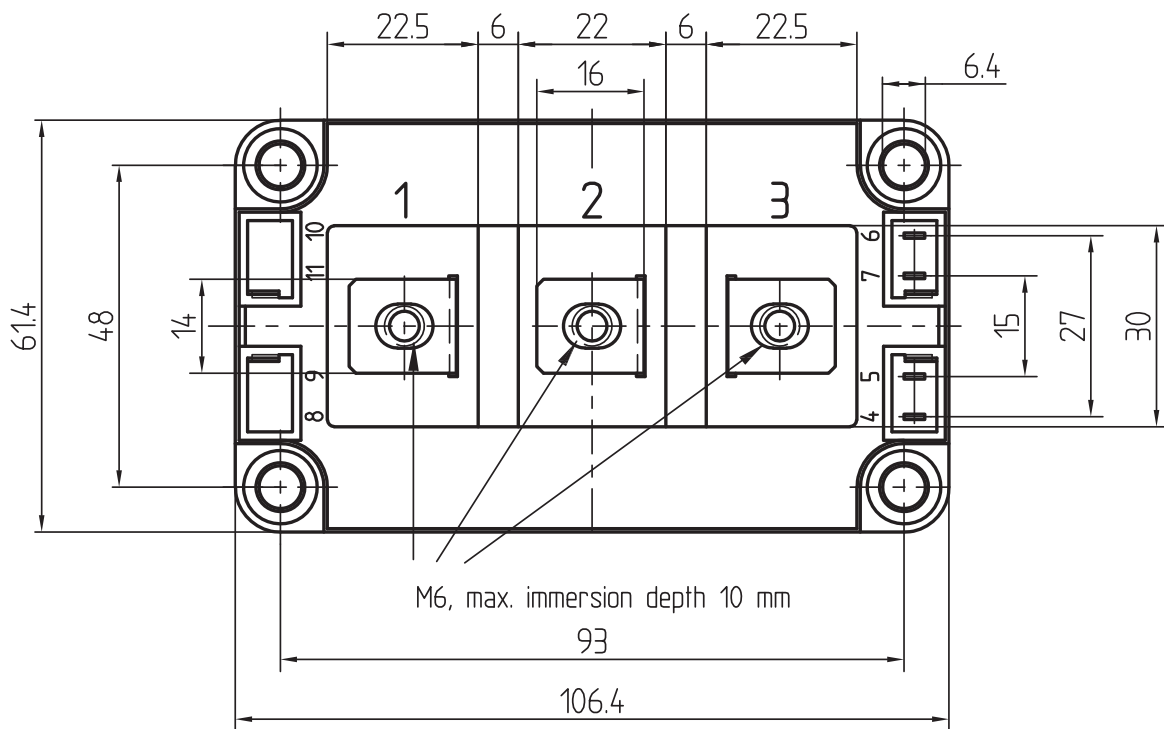
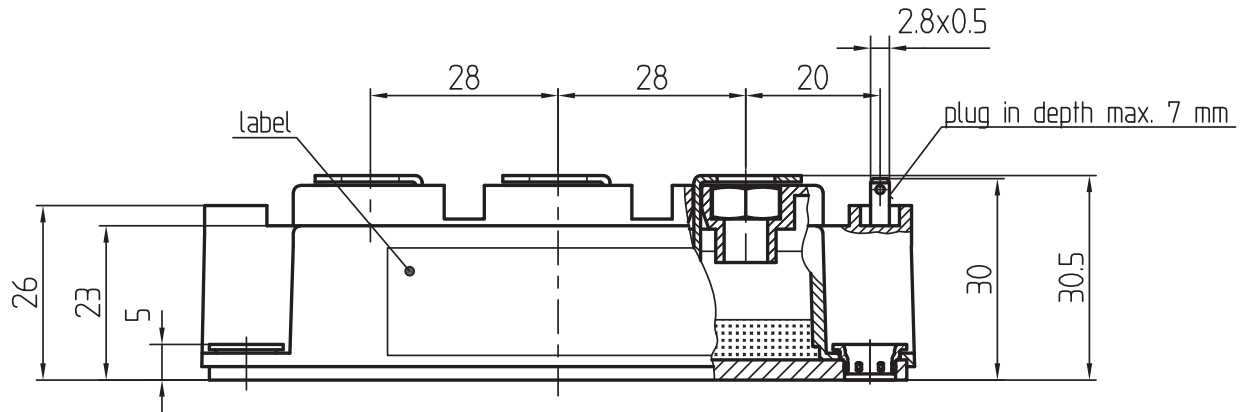

Fig. 12: Typ. CAL diode peak reverse recovery charge

SKM400GB17E4

Dimensions in mm



General tolerance +/- 0.5 mm

SEMITRANS 3

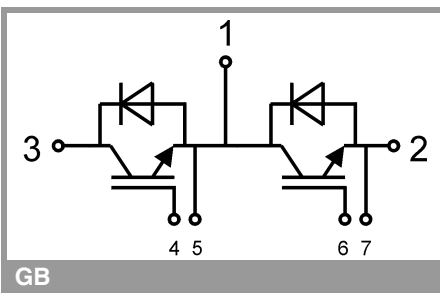

GB

IMPORTANT INFORMATION AND WARNINGS

This is an electrostatic discharge sensitive device (ESDS) according to international standard IEC 61340.

*The specifications of Semikron Danfoss products may not be considered as any guarantee or assurance of product characteristics ("Beschaffenheitsgarantie"). The specifications of Semikron Danfoss products describe only the usual characteristics of Semikron Danfoss products to be expected in typical applications, which may still vary depending on the specific application. Therefore, products must be tested for the respective application in advance. Resulting from this, application adjustments of any kind may be necessary. Any user of Semikron Danfoss products is responsible for the safety of their applications embedding Semikron Danfoss products and must take adequate safety measures to prevent the applications from causing any physical injury, fire or other problem, also if any Semikron Danfoss product becomes faulty. Any user is responsible for making sure that the application design and realization are compliant with all laws, regulations, norms and standards applicable to the scope of application. Unless otherwise explicitly approved by Semikron Danfoss in a written document signed by authorized representatives of Semikron Danfoss, Semikron Danfoss products may not be used in any applications where a failure of the product or any consequences of the use thereof can reasonably be expected to result in personal injury. No representation or warranty is given and no liability is assumed with respect to the accuracy, completeness and/or use of any information herein, including without limitation, warranties of non-infringement of intellectual property rights of any third party. Semikron Danfoss does not convey any license under its or a third party's patent rights, copyrights, trade secrets or other intellectual property rights, neither does it make any representation or warranty of non-infringement of intellectual property rights of any third party which may arise from a user's applications.