

MAKING MODERN LIVING POSSIBLE

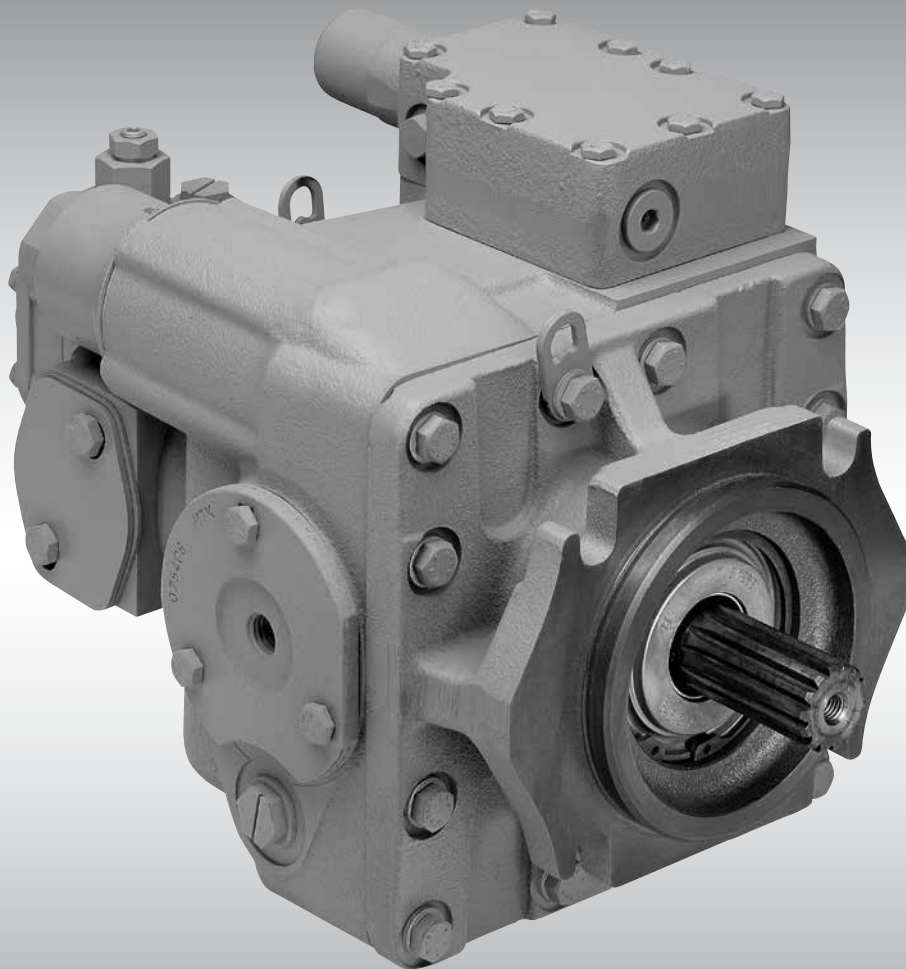

Technical Information

Axial Piston Pumps Series 20



General Description**Introduction**

Danfoss a world leader in hydraulic power systems has developed a family of axial piston pumps.

Description

Danfoss axial piston variable displacement pumps are of swash plate design with variable flow capability suitable for hydrostatic transmissions with closed loop circuit. Tilting the swash plate to the opposite side of the neutral or zero displacement position reverses flow direction.

Danfoss axial piston variable displacement pumps are well engineered and easy to handle. The full-length shaft with a highly efficient tapered roller bearing arrangement offers a high loading capacity for external radical forces. The hydro-mechanical servo displacement control maintains the selected swash plate position and hence pumps displacement. Upon release of the control handle, the swash plate automatically returns to zero position and the flow reduces to zero. High case pressures can be achieved without leakage even at the lowest temperatures by using suitable shaft seals. The servo valve arrangement offers the facility to incorporate function regulators and remote control systems. Axial piston units are designed for easy servicing. Complete dismantling and reassembly can be carried out with standard hand tools, and all components or sub-assemblies are replaceable. Axial piston variable displacement pumps of the Danfoss pattern are made by licensed producers worldwide, providing consistent service and fully interchangeable parts.

Typical markets

- Industrial
- Mining
- Transit Mixer
- Utility Vehicles

Technical Information Series 20 Axial Piston Pumps

Contents

General Description	Axial Piston Variable Displacement Pump.....	4
	Pump and Motor Circuit Description.....	5
	Pump circuit schematic	5
Technical Specification	Technical Parameters.....	6
	Design	6
	Type of mounting	6
	Pipe connections.....	6
	Direction of rotation	6
	Installation position	6
	External drain fluid loss	6
	Hydraulic Parameters	7
	System pressure range, input p_1	7
	System pressure range, output p_2	7
	Case pressure.....	7
	Hydraulic fluids	7
	Temperature range.....	7
	Viscosity range.....	7
	Filtration	7
	Shaft load.....	7
	Hydraulic Parameters	8
	Determination of Nominal Pump Sizes	8
	Based on SI units/Based on US units	8
	Servo Displacement Control (linear response)	9
	Pump flow direction	9
	Reversing time	10
	Reset time.....	11
	Changing reversing and reset time.....	11
Dimensions	Configuration PS, displacement control VML 1	12
– Frame Size 070 and 089	Configuration AA 010, displacement control VML 1	14
Dimensions	Configuration PS, displacement control VML 1	15
– Frame Size 334	Configuration AA 010, displacement control VML 1	17

General Description

Axial Piston Variable Displacement Pump

Sectional View

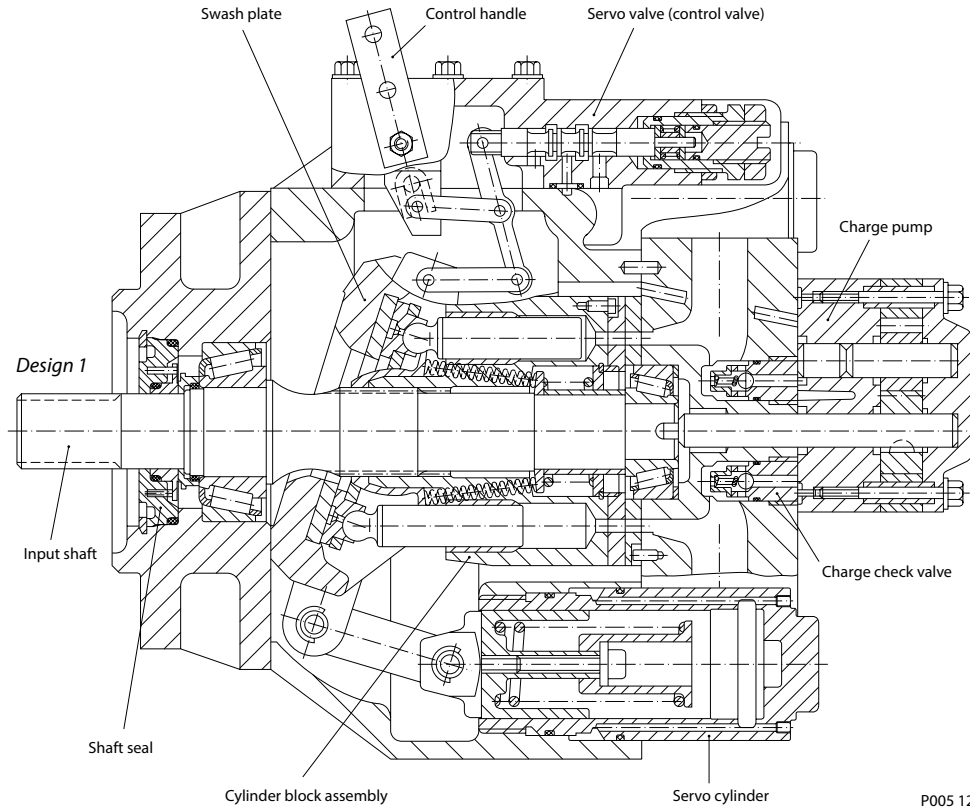

P005 121E

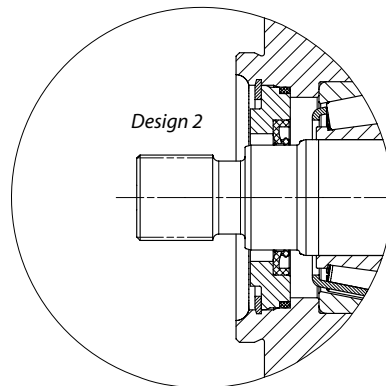

General Description

Pump and Motor Circuit Description

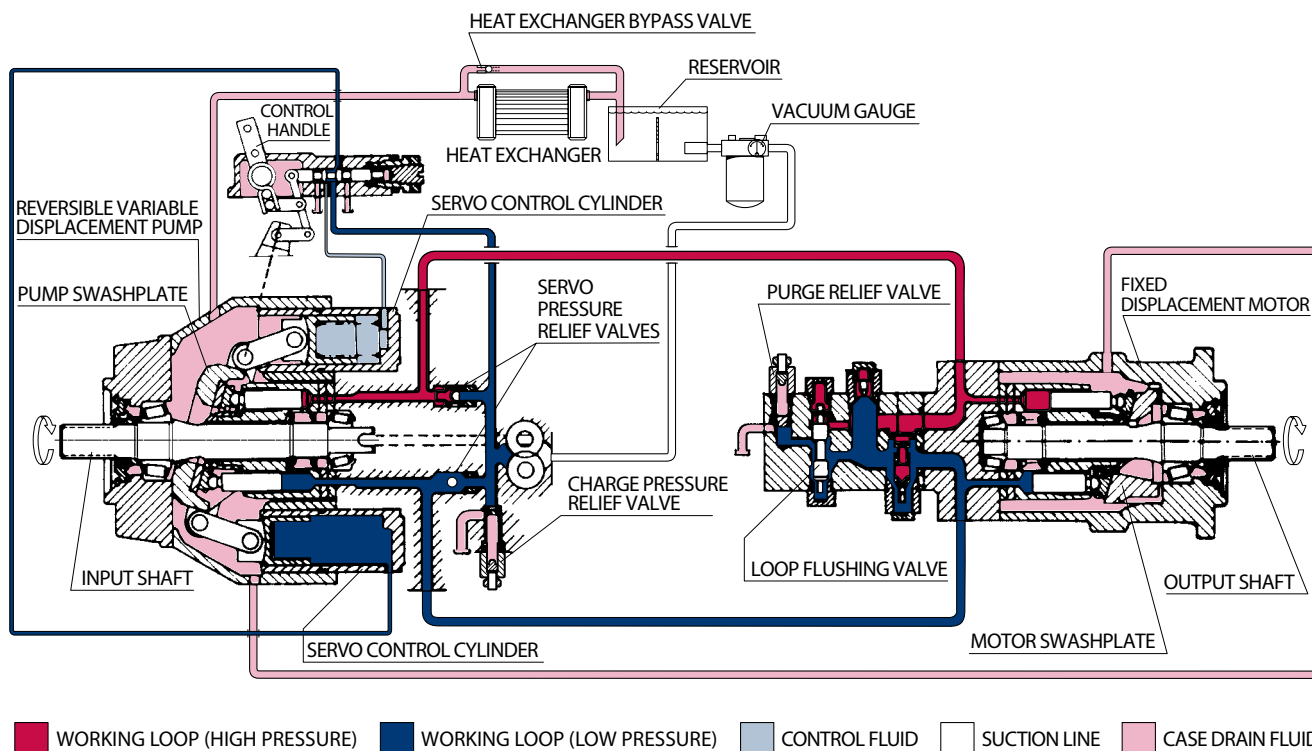

P000 027E

Above figure shows schematically the function of a hydrostatic transmission using an axial piston variable displacement pump and a fixed displacement motor.

Pump Circuit Schematic

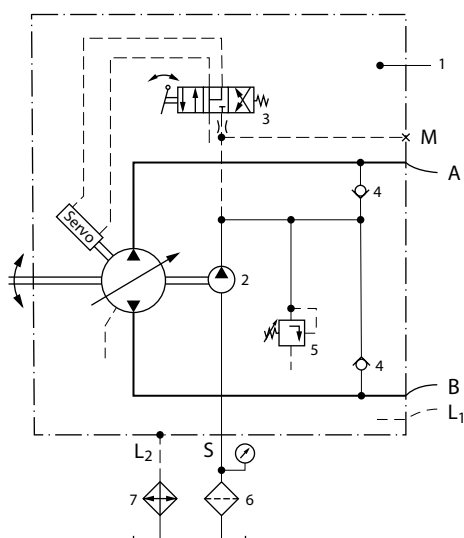

Designation:

- 1 = Variable displacement pump
- 2 = Charge pump
- 3 = Servo control valve
- 4 = Charge check valve
- 5 = Charge relief valve
- 6 = Filter
- 7 = Heat exchanger

Ports:

- A, B = Main pressure ports (working loop)
- S = Suction port - charge pump
- L1, L2 = Drain ports
- M = Gauge port - charge pressure

P000 012

Technical Specification

Technical Parameters

Design

Axial piston pump of swash plate design, with variable displacement.

Type of mounting

SAE four bolt flanges.

Pipe connections

Main pressure ports: SAE split flange

Remaining ports: SAE O-ring boss

Direction of rotation

Clockwise or counterclockwise (viewing from the input shaft).

Installation position

Optional; pump housing must be always filled with hydraulic fluid.

External drain fluid loss

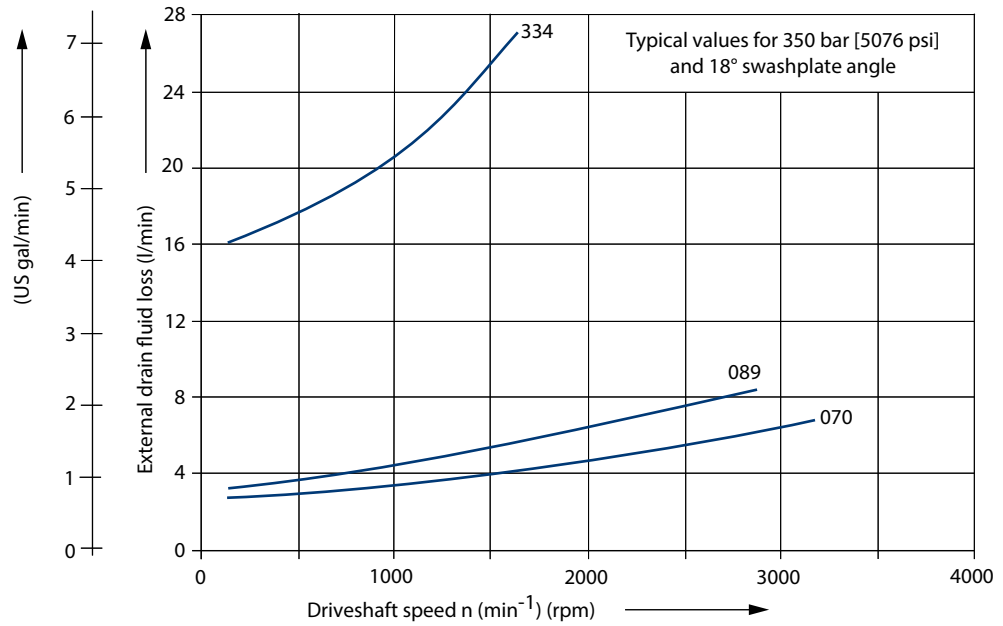

P005 105E

Technical Specification**Hydraulic Parameters****System pressure range, input p_1**

Variable displacement pump:

Charge pressure nominal: 13 bar [189 psi] above case pressure

Charge pressure minimum: 8 bar [116 psi], intermittent only

Charge pump input pressure:

Min. allowable pressure, continuous = 0.75 bar [10.9 psi] absolute

Min. allowable pressure, intermittent = 0.50 bar [7.3 psi] absolute (for cold start)

Charge pump output pressure:

Max. operating pressure = 35 bar [508 psi] above case pressure

System pressure range, output p_2 Pressure on port A or B: Max. operating pressure $\Delta p = 420$ bar [6092 psi]Max. high pressure setting $\Delta p = 460$ bar¹ [6672 psi]¹only with POR-valve**Case pressure**

Max. rated pressure = 2.5 bar [36.3 psi]

Intermittent = 5.0 bar [72.5 psi]

Hydraulic fluidsRefer to Danfoss publications [Hydraulic Fluids and Lubricants, 520L0463](#) and [Experience with Biodegradable Hydraulic Fluids, 520L0465](#).**Temperature range** $\vartheta_{\min} = -40$ °C [-40 °F] $\vartheta_{\max} = 95$ °C [203 °F]**Viscosity range** $\nu_{\min} = 7$ mm²/s [49 SUS*] $\nu_{\max} = 1000$ mm²/s [4630 SUS*] (intermittent cold start)Recommended viscosity range: 12 - 60 mm²/s [66 - 280 SUS*]

*SUS (Saybolt Universal Second)

FiltrationRequired cleanliness level: ISO 4406 - 1999 Code 22/18/13 or better. Refer to Danfoss publication [Hydraulic Fluids and Lubricants, 520L0463](#) and [Design Guideline for Hydraulic Fluid Cleanliness, 520L0467](#).**Shaft load**

The pump will accept radial and axial loads on its shaft, the maximum capacity being determined by direction and point of application of the load. Please contact your Danfoss representative.

Technical Specification
**Hydraulic Parameters
(continued)**
Technical Data

Parameter		Units	Frame size		
			070	089	334
Max. displacement		cm ³ [in ³]	69.8 [4.26]	89.0 [5.43]	333.7 [20.36]
Charge pump displacement	options	cm ³ [in ³]	18.03 [1.10]		65.50 [4.00]
			12.30 [0.75]		-
Minimum speed		min ⁻¹ (rpm)	500		
Rated speed 1		min ⁻¹ (rpm)	3200	2900	1900
Maximum swash plate angle		degree	±18		
Mass moment of inertia of rotating group (without charge pump)		kg m ² · 10 ⁻³ [lbf ft ² · 10 ⁻³]	12.34 [292.8]	17.77 [421.7]	161.40 [3830.0]
Weight		kg [lb]	63 [139]	78 [172]	270 [595]

¹ for higher speeds contact your Sauer-Danfoss representative.

**Determination of Nominal
Pump Sizes**

Use these formulae to determine the nominal pump size for a specific application:

Based on SI units
Based on US units

Output flow: $Q = \frac{V_g \cdot n \cdot \eta_v}{1000} \text{ l/min}$

$Q = \frac{V_g \cdot n \cdot \eta_v}{231} \text{ [US gal/min]}$

Input torque: $M = \frac{V_g \cdot \Delta p}{20 \cdot \pi \cdot \eta_m} \text{ N}\cdot\text{m}$

$M = \frac{V_g \cdot \Delta p}{2 \cdot \pi \cdot \eta_m} \text{ [lbf}\cdot\text{in]}$

Input power: $P = \frac{M \cdot n}{9550} = \frac{Q \cdot \Delta p}{600 \cdot \eta_t} \text{ kW}$

$P = \frac{M \cdot n}{63.025} = \frac{Q \cdot \Delta p}{1714 \cdot \eta_t} \text{ [hp]}$

Variables: SI units [US units]

V_g = Displacement per rev. cm³/rev [in³/rev]
 p_{HD} = Outlet pressure bar [psi]
 p_{ND} = Inlet pressure bar [psi]
 Δp = $p_{HD} - p_{ND}$ bar [psi]
 n = Speed min⁻¹ (rpm)
 η_v = Volumetric efficiency
 η_m = Mechanical (torque) efficiency
 η_t = Overall efficiency ($\eta_v \cdot \eta_m$)

Technical Specification

Servo Displacement Control (linear response)

Regulated by the control handle on the servo valve, the swash plate can be infinitely varied in both directions with the help of the servo system. The pump displacement resulting from any control handle position can be established using the figures on this page.

The angle of the control handle for stroke initiation and for the final position of the stroke can vary from unit to unit within the range of the tolerance band.

The inter-relation of flow direction, rotation of the pump and the control handle movement is shown below.

Pump flow direction

Flow direction changes with the direction of rotation and the control handle movement (see *besides*).

Pump rotation	Movement of control handle in direction	Pressure port OUT	Pressure port IN
CCW (Left)	C	B	A
	D	A	B
CW (Right)	C	A	B
	D	B	A

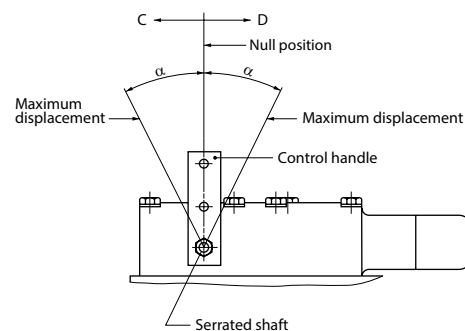

P000 013E

SPV2/070

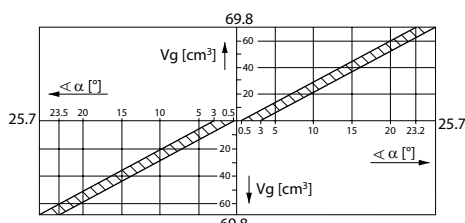

P000 016

SPV2/089

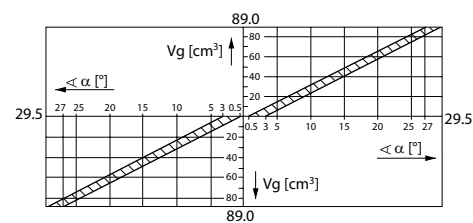

P000 017

SPV2/334

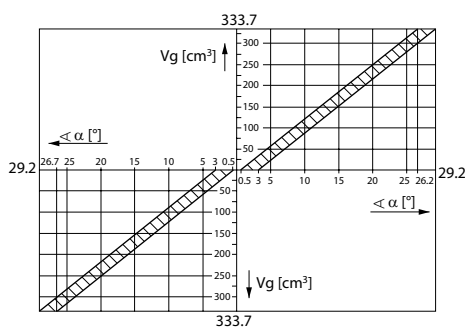

P000 021

Technical Specification

**Servo Displacement Control
(linear response)
(continued)**

Reversing time

Time for the directional change of the flow from Q_{max} , across zero to Q_{max} , depending on the size of the control orifice fitted in the supply port to the servo valve (see *below*).

The values given assume movement of the control handle directly from one end position to the other.

Adjustment time of handle: < minimum reserving time
 Operating pressure: $\Delta p_2 = 210 \text{ bar [3046 psi]}$
 Speed: $n = 1450 \text{ min}^{-1} \text{ (rpm)}$
 System temperature: $50 \text{ }^\circ\text{C [122 }^\circ\text{F]}$
 Viscosity: $35 \text{ mm}^2/\text{s [164 SUS]}$

Frame size	Minimum reversing time (s) without orifice	Maximum reversing time (s) with orifice $\varnothing 0.66$ in supply port
070	1.0	9.3
089	1.1	9.0
334	5.6	43.8

Schematic diagram of servo valve with alternative orifice positions

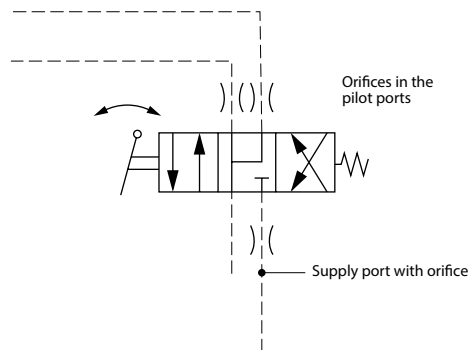

P000 056E

Technical Specification
**Servo Displacement Control
(linear response)
(continued)**
Reset time

Time for reducing the flow from either flow direction from Q_{max} to 0 releasing the control handle. Assuming no mechanical blockage of the control handle's free return and assuming no orifices in the pilot ports:

Operating pressure: $\Delta p_2 = 210 \text{ bar [3046 psi]}$
 System temperature: $50 \text{ }^\circ\text{C [122 }^\circ\text{F]}$
 Viscosity: $35 \text{ mm}^2/\text{s [164 SUS]}$

Changing reversing and reset time

Servo valve counter bored recesses for orifice insert

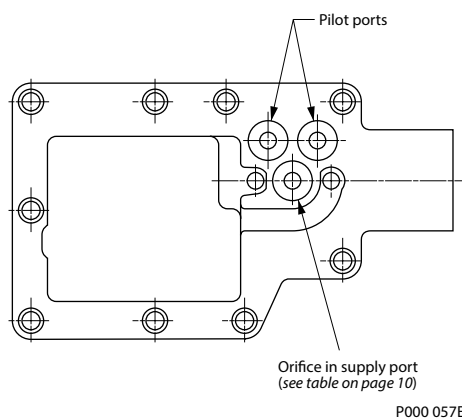

Frame size	Minimum reset time (s)
070	3.0
089	
334	5.4

Inserting one orifice in each of the pilot ports can extend the reversing time. The reset time will also be extended.

Inserting an orifice in one of the pilot ports only can extend the reversing time in one flow direction. The reset time will be extended only for this flow direction.

Dimensions

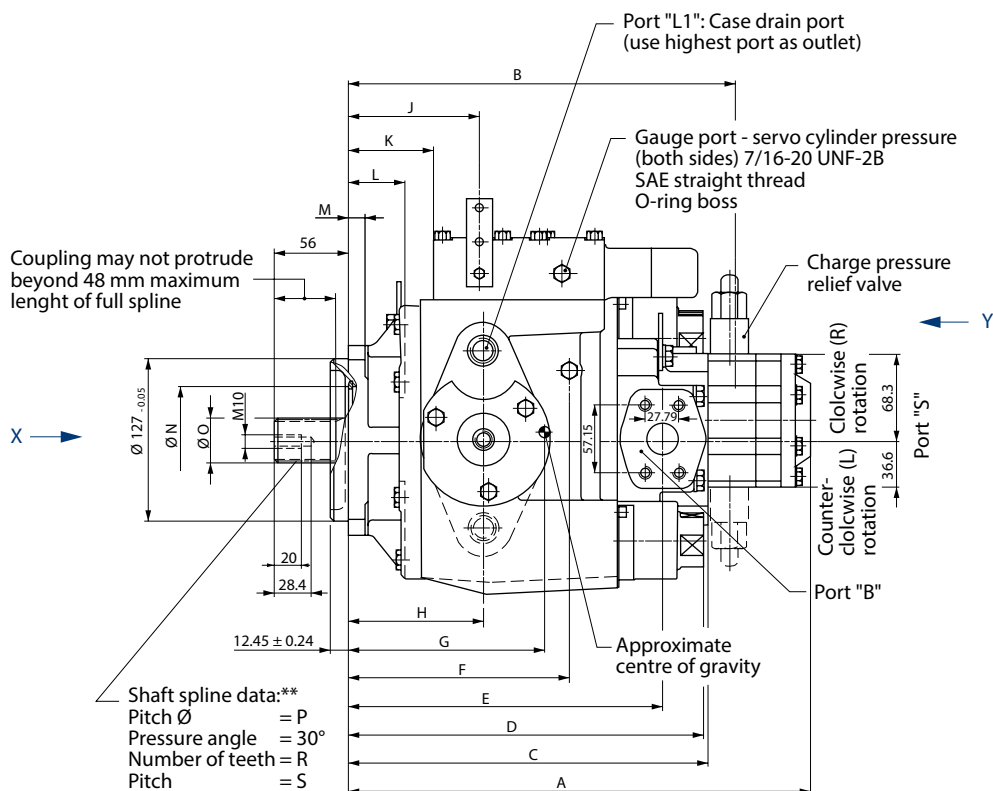
 – Frame Size 070 and 089 cm³
**Configuration PS,
displacement control VML 1**

P005 106E

 * Minimum and maximum angle α , (see section *Servo displacement control*).

** Shaft spline data: spline shaft with involute spline, according to SAE handbook, 1963, class 1, fillet root side fit.

Dimensions - mm [in]

Frame size	B	C	D	E	F	G	H	J	K	L	M	Ø N
070	315 [12.402]	294 [11.575]	305 [12.008]	259 [10.197]	188 [7.402]	146 [5.748]	112 [4.409]	120 [4.724]	84 [3.307]	48 [1.890]	16 [0.630]	84 [3.307]
089	328 [12.913]	307 [12.087]	312 [12.283]	271 [10.669]	195 [7.677]	140 [5.512]	118 [4.646]	129 [5.079]	91 [3.583]	49 [1.929]	17.5 [0.689]	98 [3.858]

Frame size	A ¹		Shaft spline				Bore Ø for shaft coupling
	Charge pump 12 cm ³	18 cm ³	Ø O	Ø P	R	S	
070	372 [14.646]	381 [15.000]	34.50 ^{-0.17} [1.358 ^{-0.0067}]	33.338 [1.313]	21 [0.827]	16/32	31.75 ^{+0.062} [1.250 ^{+0.0024}]
089	358 [14.094]	394 [15.512]	37.68 ^{-0.17} [1.483 ^{-0.0067}]	36.513 [1.438]	23 [0.906]	16/32	34.95 ^{+0.062} [1.376 ^{+0.0024}]

¹ Short version available on request. Please contact your local Danfoss representative.

Dimensions - mm [in]

Frame size	T	U	V	W	X	Y	Z
070	71.4 [2.811]	112.7 [4.437]	105 [4.134]	108 [4.252]	60.5 [2.382]	85.8 [3.378]	9.5 [0.374]
089	77.7 [3.059]	128.7 [5.067]	115 [4.528]	119 [4.685]	65 [2.559]	95.2 [3.748]	12.7 [0.500]

Technical Information Series 20 Axial Piston Pumps

Dimensions – Frame Size 070 and 089 cm³

Configuration PS, displacement control VML 1 (continued)

View X (for SPV 2/070 only)

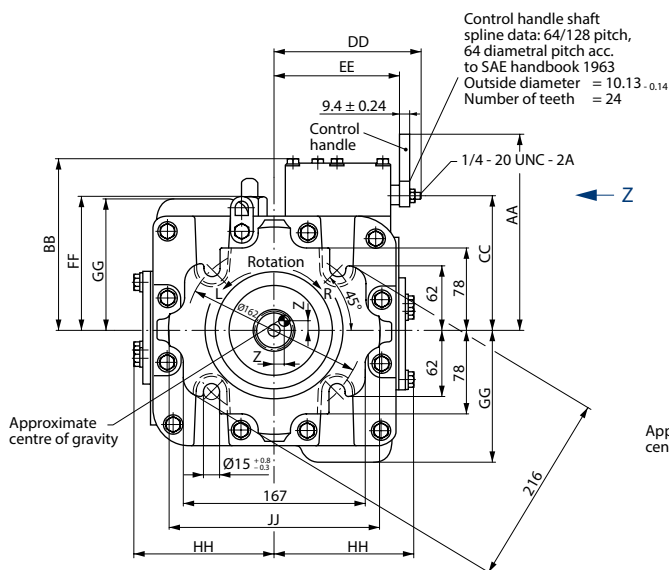

View X (for SPV 2/089 only)

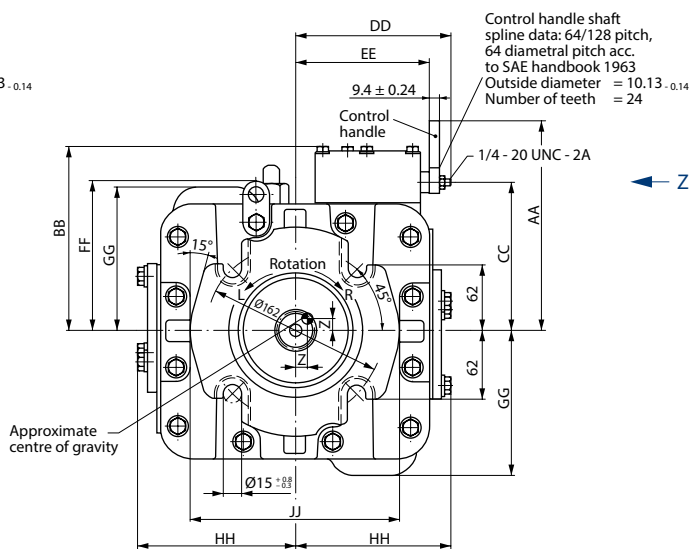

P005 108E

Frame size	AA	BB	CC	DD	EE	FF	GG	HH	JJ
070	187.6 [7.386]	162 [6.378]	128.6 [5.063]	133 [5.236]	113 [4.449]	126 [4.961]	123 [4.843]	130 [5.118]	194 [7.638]
089	198.6 [7.819]	173 [6.811]	139.6 [5.496]	144 [5.669]	123 [4.843]	140 [5.512]	134 [5.276]	148 [5.827]	194 [7.638]

View Y

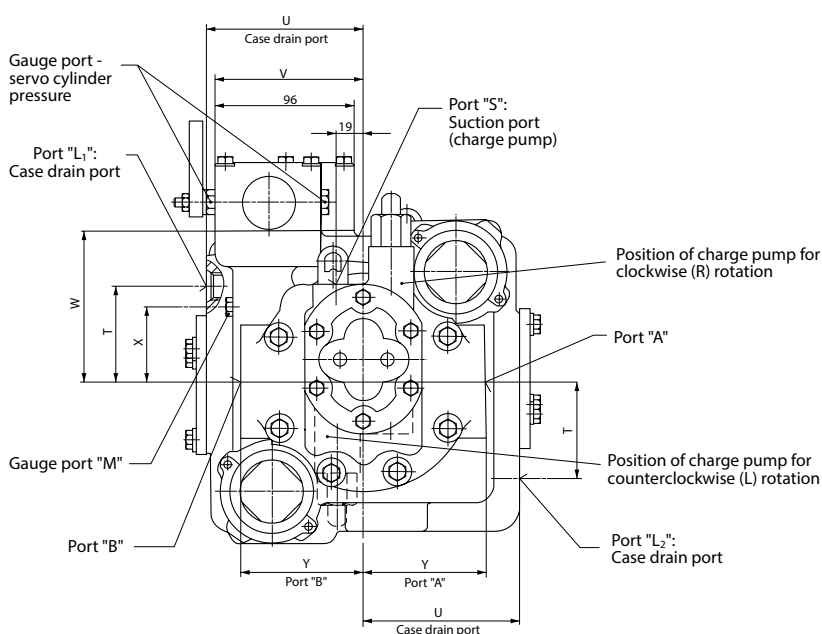

View Z

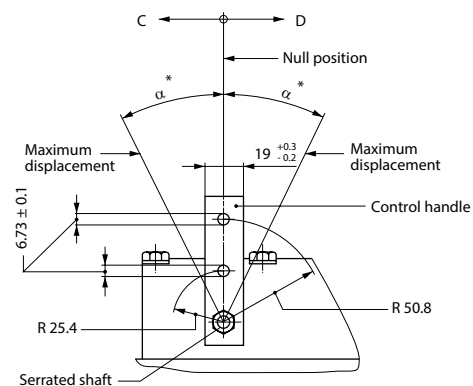

P000 022E

P005 107E

Dimensions

– Frame Size 070 and 089 cm³

**Configuration AA 010,
displacement control VML 1**

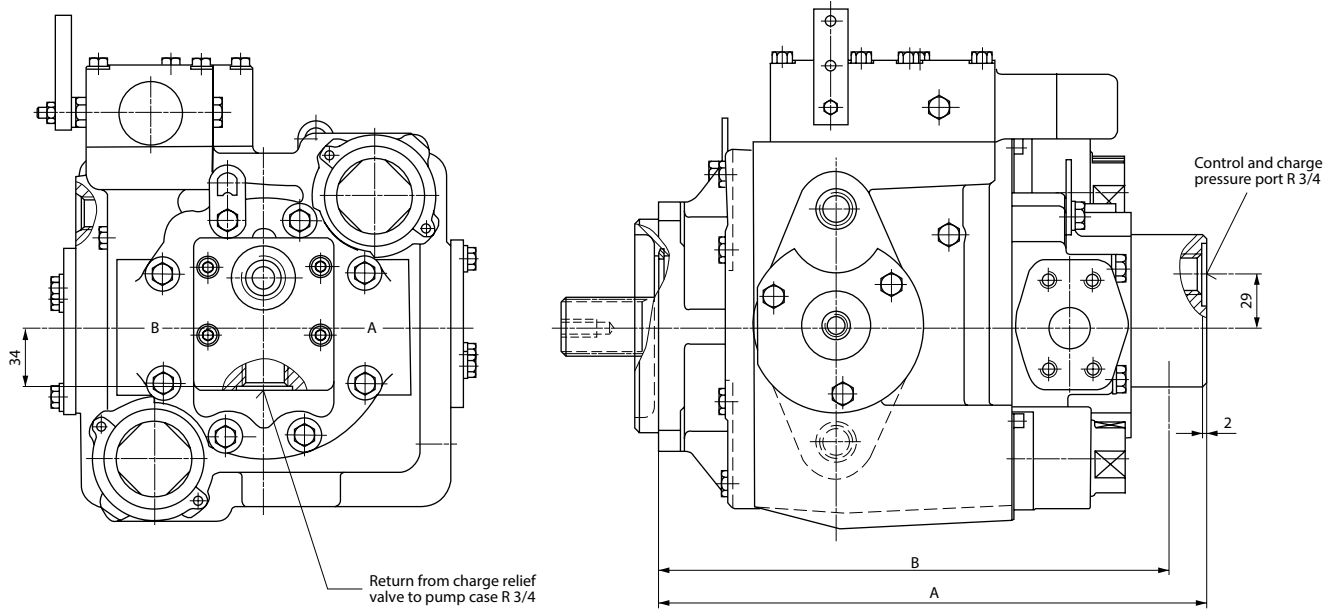

P000 009E

Dimensions - mm [in]

Frame Size	A	B	Weight kg [lb]
070	339 [13.346]	316 [12.441]	63.5 [140]
089	352 [13.858]	329 [12.953]	78.5 [173]

Circuit schematic

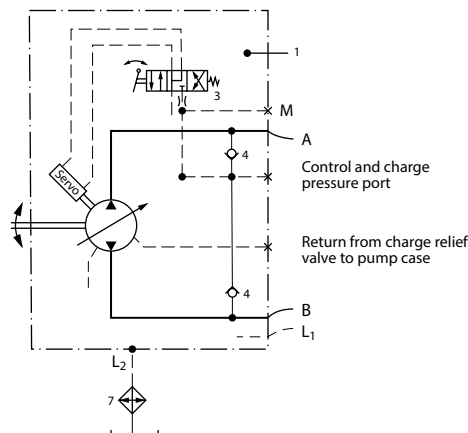

Designation:

- 1 = Variable Displacement pump
- 3 = Servo control valve
- 4 = Charge check valve
- 7 = Heat exchanger

Ports:

- A, B = Main pressure ports (working loop)
- L1, L2 = Drain ports
- M = Gauge port - charge pressure

P000 058E

Dimensions
– Frame Size 334 cm³

**Configuration PS,
displacement control VML 1**

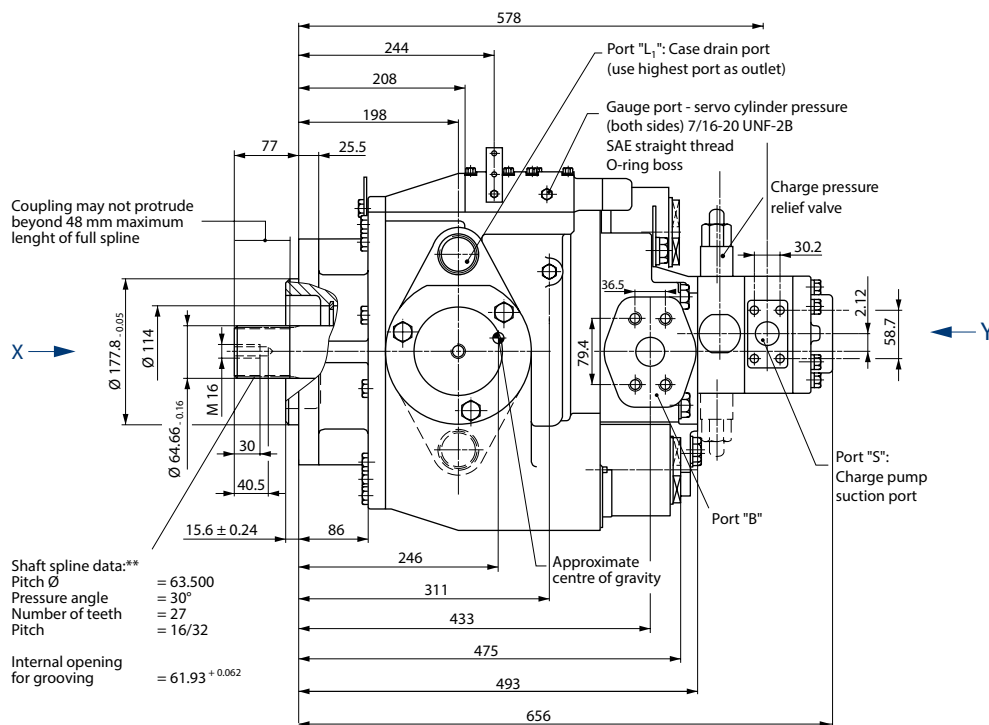

P005 115E

* Minimum and maximum angle α , (see section *servo displacement control*).

** Shaft spline data: spline shaft with involute spline, according to SAE handbook, 1963, class 1, fillet root side fit.

Dimensions

– Frame Size 334 cm³

**Configuration PS,
displacement control VML 1
(continued)**

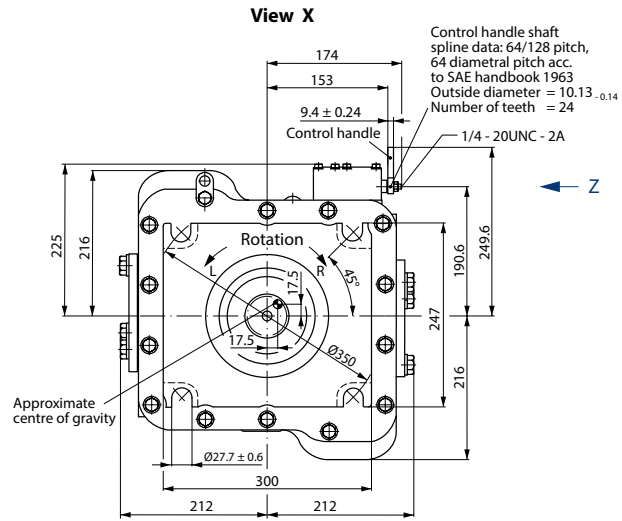
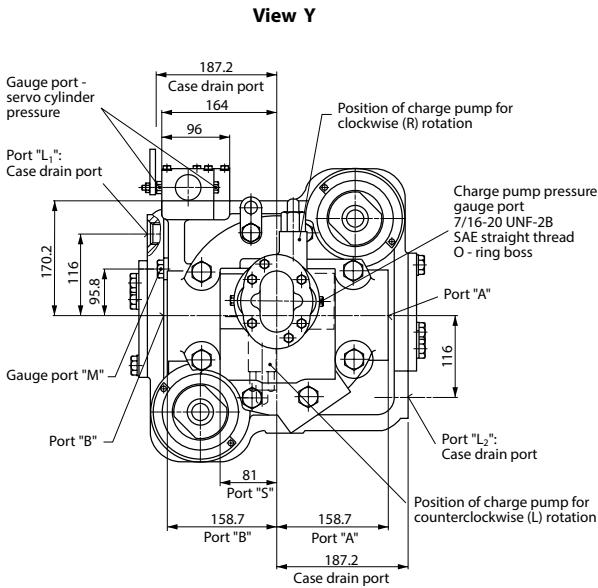

P005 111E

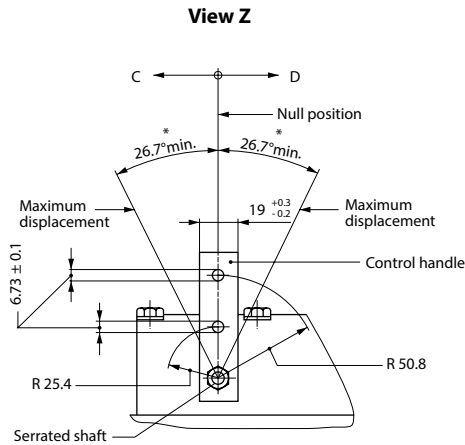

P000 026E

- Port A and B:** SAE flange, size 1 1/2 SAE split flange boss, 6000 psi, 4 threads, 5/8-11 UNC-2B, 35 deep
- Port L1, L2:** 1 7/8-12 UNF-2B, SAE straight thread, O-ring boss
- Port S:** SAE flange, 1 1/4 SAE split flange boss, 3000 psi, 4 threads, 7/16-14 UNC-2B, 28 deep
- Port M:** 7/16-20 UNF-2B, SAE straight thread, O-ring boss

Dimensions

– Frame Size 334 cm³

**Configuration AA 010,
displacement control VML 1**

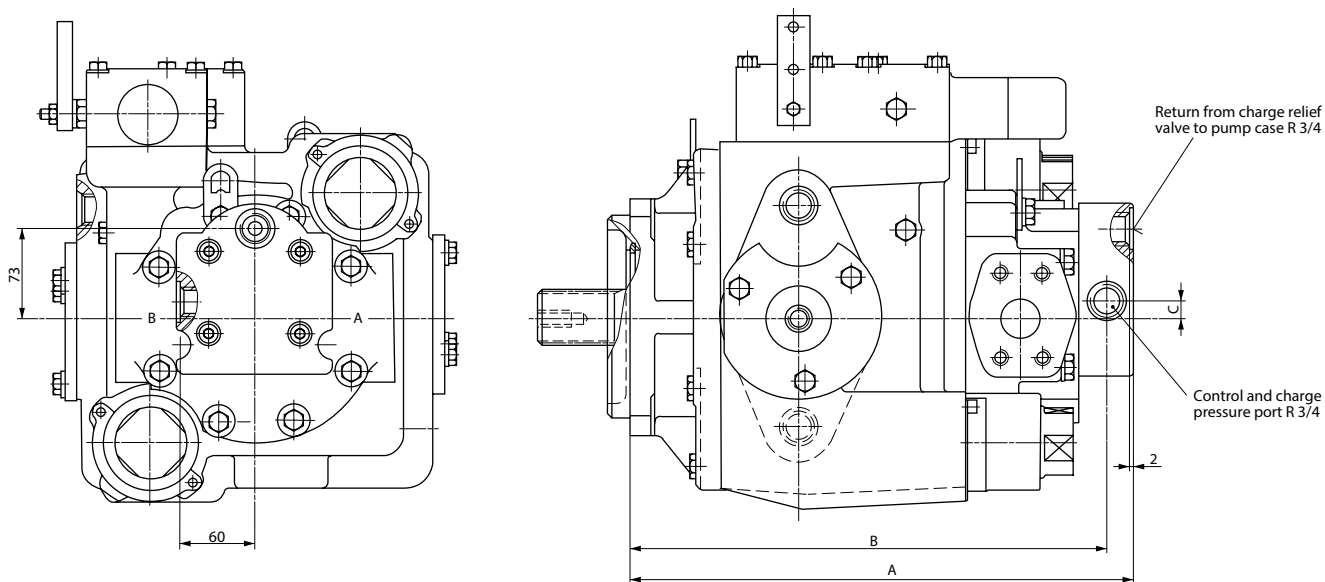

P000 010E

Dimensions - mm [in]

Frame size	A	B	C	Weight kg [lb]
334	546 [21.496]	520 [20.472]	21 [0.827]	264.5 [583]

Circuit schematic

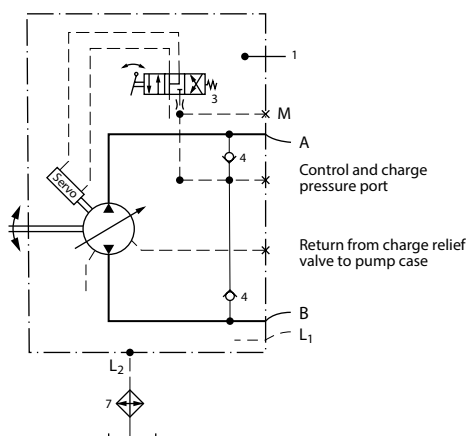

Designation:

- 1 = Variable Displacement pump
- 3 = Servo control valve
- 4 = Charge check valve
- 7 = Heat exchanger

Ports:

- A, B = Main pressure ports (working loop)
- L1, L2 = Drain ports
- M = Gauge port - charge pressure

P000 058E



Products we offer:

- Bent Axis Motors
- Closed Circuit Axial Piston Pumps and Motors
- Displays
- Electrohydraulic Power Steering
- Electrohydraulics
- Hydraulic Power Steering
- Integrated Systems
- Joysticks and Control Handles
- Microcontrollers and Software
- Open Circuit Axial Piston Pumps
- Orbital Motors
- PLUS+1® GUIDE
- Proportional Valves
- Sensors
- Steering
- Transit Mixer Drives

Danfoss Power Solutions is a global manufacturer and supplier of high-quality hydraulic and electronic components. We specialize in providing state-of-the-art technology and solutions that excel in the harsh operating conditions of the mobile off-highway market. Building on our extensive applications expertise, we work closely with our customers to ensure exceptional performance for a broad range of off-highway vehicles.

We help OEMs around the world speed up system development, reduce costs and bring vehicles to market faster.

Danfoss – Your Strongest Partner in Mobile Hydraulics.

Go to www.powersolutions.danfoss.com for further product information.

Wherever off-highway vehicles are at work, so is Danfoss.

We offer expert worldwide support for our customers, ensuring the best possible solutions for outstanding performance. And with an extensive network of Global Service Partners, we also provide comprehensive global service for all of our components.

Please contact the Danfoss Power Solution representative nearest you.

Comatrol

www.comatrol.com

Schwarzmueller-Inverter

www.schwarzmueller-inverter.com

Turolla

www.turollaocg.com

Valmova

www.valmova.com

Hydro-Gear

www.hydro-gear.com

Daikin-Sauer-Danfoss

www.daijin-sauer-danfoss.com

Local address:

Danfoss Power Solutions (US) Company

2800 East 13th Street
Ames, IA 50010, USA
Phone: +1 515 239 6000

Danfoss Power Solutions GmbH & Co. OHG

Krokamp 35
D-24539 Neumünster, Germany
Phone: +49 4321 871 0

Danfoss Power Solutions ApS

Nordborgvej 81
DK-6430 Nordborg, Denmark
Phone: +45 7488 2222

Danfoss Power Solutions Trading (Shanghai) Co., Ltd.

Building #22, No. 1000 Jin Hai Rd
Jin Qiao, Pudong New District
Shanghai, China 201206
Phone: +86 21 3418 5200

Danfoss can accept no responsibility for possible errors in catalogues, brochures and other printed material. Danfoss reserves the right to alter its products without notice. This also applies to products already on order provided that such alterations can be made without changes being necessary in specifications already agreed. All trademarks in this material are property of the respective companies. Danfoss and the Danfoss logotype are trademarks of Danfoss A/S. All rights reserved.