



ENGINEERING
TOMORROW

Danfoss

Environmental **Product Declaration**



DEVlreg™ Basic
DEVlreg™ Room

EPD issued	2025-10-22
EPD expires	2030-10-22
EPD author	Danfoss Climate Solutions
EPD type	Cradle-to-gate with options
Declared unit	One product over its 10 years of Reference Service Life
Products included	DEVlreg™ Basic Polar white (140F1164) DEVlreg™ Room Polar white (140F1165)
Manufacturing Location	Thailand
Use Location	Finland
Application	Combined, room or floor temperature control
Mass	0,142 kg no packaging / 0,153 kg no packaging (Room) 0,194 kg with packaging / 0,204 kg with packaging (Room)
Dimensions (HxWxD)	88 x 88 x 20-24 mm without packaging
Verification	<input type="checkbox"/> External <input checked="" type="checkbox"/> Internal <input type="checkbox"/> None
Produced to	Danfoss Product Category Rules (2022-09)
Internal independent verifier	Danfoss Power Electronics & Drives A/S

DISCLAIMER

This EPD was prepared to the best of knowledge of Danfoss A/S. The life cycle assessment calculations were performed in accordance with ISO 14040 & 14044 and EN15804+A2.

All results were internally reviewed by independent experts. While this declaration has followed the guidance of ISO 14025, it has not been externally verified or registered by an EPD programme and therefore does not fully comply with the ISO 14025 standard.

This EPD has been published by Danfoss A/S on Danfoss Product Store and Danfoss Website. For questions, feedback or requests please contact your Danfoss sales representative.

Introduction

This Environmental Product Declaration (EPD) follows the Danfoss Product Category Rules (PCR) (2022-09-20). These rules provide a consistent framework for calculating and reporting the environmental performance of Danfoss' products and is aligned with relevant international standards, particularly ISO 14025:2006, EN 15804+A2:2019 and EN 50598-3:2015.

This document has been produced by Danfoss A/S following an internal verification process, but it is not a third-party verified document.

What is an EPD?

An EPD is a document used to communicate transparently the quantified environmental impacts of a product over its lifecycle stages. This quantification is done by performing a Life Cycle Assessment (LCA) in line with a consistent set of rules known as a PCR (Product Category Rules).

An EPD provides:

- A product's carbon footprint together with other relevant environmental indicators, including air pollution, water use, energy consumption and waste, over its own life cycle (Modules A-C), as well as the expected benefits of reuse and recycling in reducing the impact of future products (Module D). See Table 1 for module descriptions.
- Environmental data allowing customers to calculate LCAs and produce EPDs for their own products.

Type of EPD

This EPD is of the type 'cradle-to-gate with options' and includes all relevant modules: production (A1-A3), shipping (A4) and installation (A5); operational energy use (B6); deconstruction (C1), waste collection and transport (C2), treatment (C3) and disposal (C4). It also includes potential net benefits to future products from recycling or reusing post-consumer waste (D). The codes in brackets are the module labels from EN 15804+A2. Modules concerning use, maintenance, repair, replacement, refurbishment (B1-B5) and operational water use (B7) are excluded, following the cut-off rules from EN 15804.

Table 1: Modules of the product's life cycle included in the EPD

Product stage			Installation		Use stage							End-of-life stage				Benefits
Raw materials	Transport	Manufacture	Transport	Installation	Use	Maintenance	Repair	Replacement	Refurbishment	Operational energy use	Operational water use	De-install.	Transport	Waste processing	Disposal	Benefits and loads outside system boundaries
A1	A2	A3	A4	A5	B1	B2	B3	B4	B5	B6	B7	C1	C2	C3	C4	D
X	X	X	X	X	MNR	MNR	MNR	MNR	MNR	X	MNR	X	X	X	X	X

(X = declared module; MNR = module not relevant)

Product Description

The product covered by this EPD is representative of DEVIreg™ Room and DEVIreg™ Basic. The production location is the Danfoss plant in Bangkok, Thailand. See more information on [Danfoss Product Store DEVIreg Basic](#) and [Danfoss Product Store DEVIreg Room](#). The calculations were done for the heavier thermostat DEVIreg™ Room Polar white (140F1165).

The DEVIreg™ Basic (140F1164) an intuitive programmable timer thermostat, for floor temperature control, complying with Eco design Lot 20, used for controlling electric floor heating elements.

The DEVIreg™ Room (140F1165) is an intuitive programmable timer thermostat, for combined, room or floor temperature control, complying with Eco design Lot 20, used for controlling electrical floor heating elements, according to the room temperature.



Figure 1.1: The exploded illustration of the DEVIreg™ Basic with frame and power supply unit.

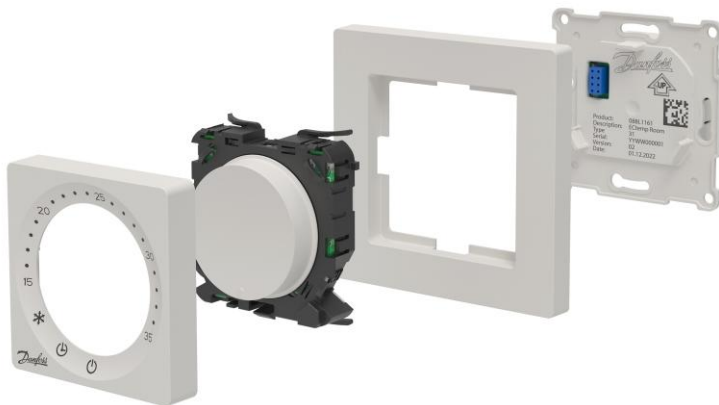

Product Description

Figure 2.2: The exploded illustration of the DEVIreg™ Room with frame and power supply unit.

The thermostat has a packaging that is the World's first Cradle to Cradle Gold-certified packaging for DEVI by Danfoss – KLS PurePrint. Amongst the features, the packaging:

- Does not contain harmful, banned chemicals;
- Is recyclable, biodegradable and compostable;
- Is easy to disassemble and all components can be reused;



Figure 1.3: Picture of the packaging

Reference Service Life

For the purpose of this EPD the reference service life (RSL) of the product is considered to be 10 years.

Intended market

The intended market of this study is Finland and the baseline scenario involves the distribution, installation, and end-of-life in Finland. With regards to the use stage and the end-of-life stage, this EPD is not representative of regions other than Finland.

Product Description

Table 2: Product composition

Material	Mass (kg)	%
Plastics	0,061	43,5%
Polycarbonate, mix	0,061	43,5%
Electrical/electronic	0,079	56,5%
Cables	0,039	27,7%
PCBA	0,040	28,8%
Total product	0,140	100,0%
Packaging	0,064	100,0%
Paper and cardboard	0,064	100,0%
Total product	0,204	100,0%

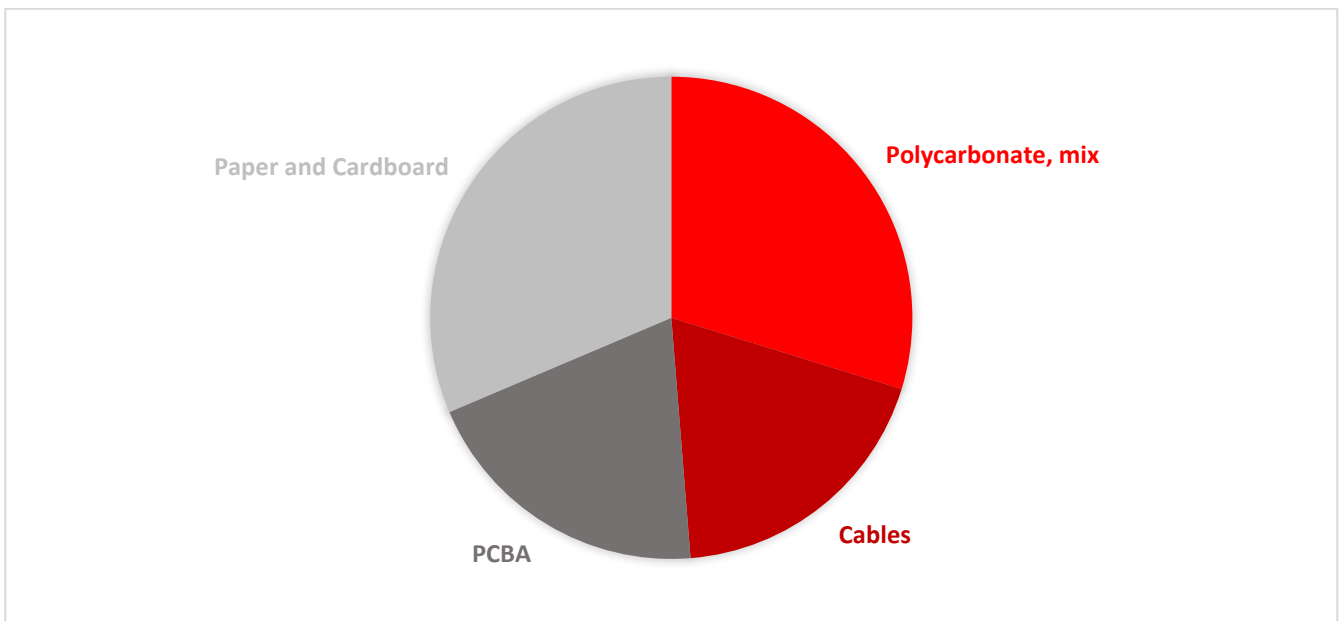

Figure 3: Material Composition Overview (product and packaging)

Overview of LCA study

Data quality

Data quality of the selected datasets is generally assessed as good and very good in terms of geographical, time and technology representativeness and applicability. Background data is from *LCA for Experts*© database version 2025.2.

Allocation and cut-off criteria

The allocation is made in accordance with the provisions of EN 15804+A2. All major raw materials and all the essential energy are included. All hazardous materials and substances are considered in the inventory. Data sets within the system boundary are complete and fulfil the criteria for the exclusion of inputs and output criteria.

System boundaries

The results in this EPD are split into life cycle modules following EN 15804 (Figure 1): production (A1-A3), distribution (A4), use (B6) and the end of the product's life (C1-C4). Module D represents environmental benefits and loads that occur beyond the system boundary (i.e., in future products).

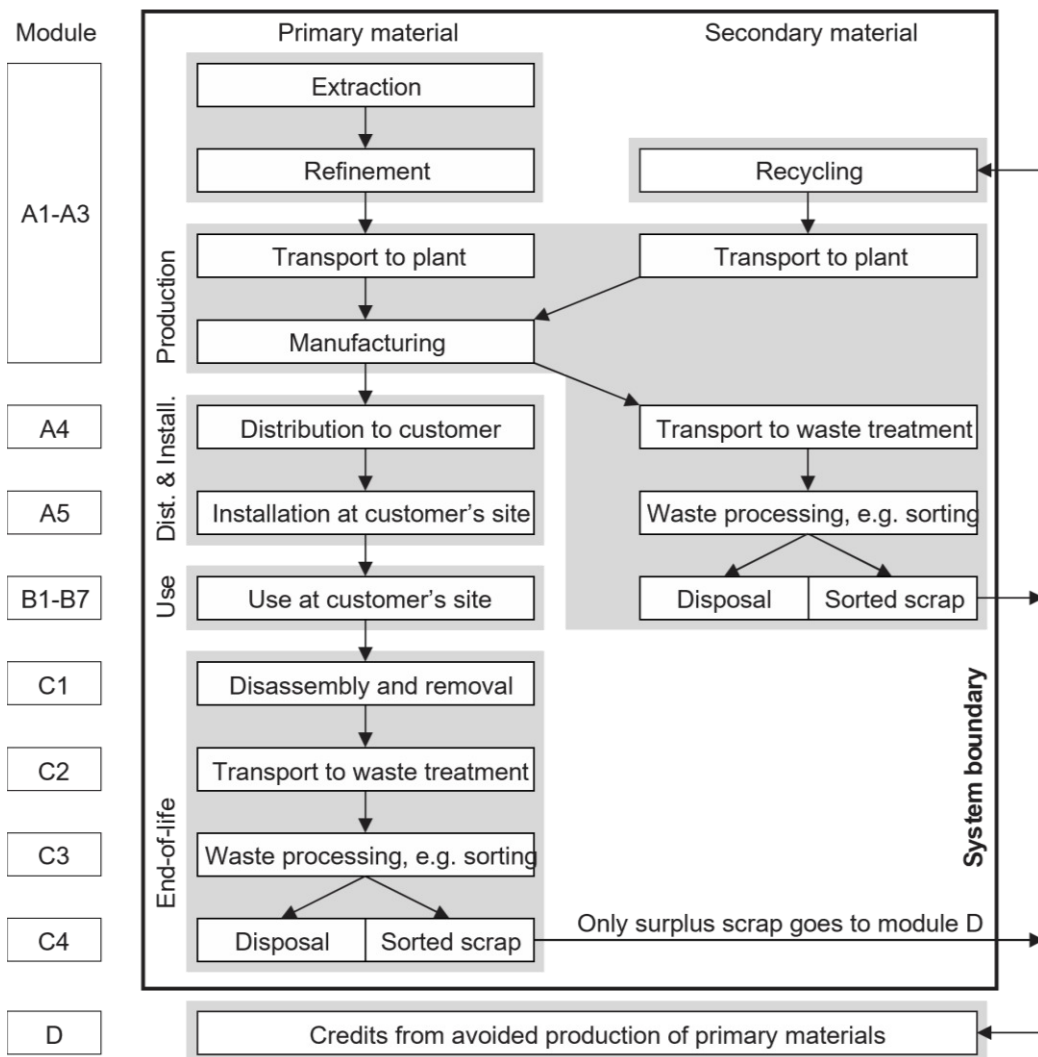

Figure 3: Modular structure used in this EPD (following EN 15804+A2)

Overview of LCA study

Product and packaging manufacture (A1-A3)

Final manufacturing occurs in the Bangkok, Thailand at external vendor. The product is shipped with the packaging to Nordborg, Denmark, where the documentation added to it before distribution to customers. Where waste generated on-site is recyclable, it is separated and recycled. The product is shipped in the packaging as described in Table 1. All packaging materials can be safely recycled or incinerated if appropriate local facilities are available. Data was collected for 2025.

Table 3: Biogenic carbon content in product and packaging

	Total (excluding recycling)
Biogenic carbon content in product [kg]	-
Biogenic carbon content in accompanying packaging [kg]	0,028

Note: 1 kg biogenic carbon is equivalent to 44/12 kg of CO₂.

Shipping and installation (A4-A5)

Distribution is assumed to occur to customers within Finland. Transportation at 1510 km distance by truck is assumed between the factory and the final customers. This assumption was made as an average distance within Finland.

Module A5 includes disposal of packaging materials only, the benefits from e.g., energy recovered after plastic incineration are allocated to module D. The product is assumed to be installed by hand. Energy use in handheld tools during installation is not included as it falls under the cut-off criteria.

Use phase (B1-B7)

The electricity consumption by the thermostats during the use phase (B6) is regulated by the *Eco-design Lot 20* directive. The use scenario considered here is an average scenario to represent a range of applications, depending on external and environmental conditions. The estimated electricity consumption is provided by product experts at Danfoss Climate Solutions.

The energy consumption is calculated considering 10 years of Reference Service Life. The daily operation during the year is estimated to be around 100 days. The thermostat is in active mode on average 3 hours per day, the majority of the operation is in standby mode with an average of 19 hours per day, and the rest of the 2 hours the thermostat is in idle mode.

Power consumption was measured using a Rohde & Schwarz NPA 701. The device is connected directly to the main power input and provides accurate readings of power consumption. The measurements were done by a Danfoss electrical engineer.

The scope of this study is targeted for the Finnish market; therefore, the product under study is sold and used in Finland. Sales also occur outside of Finland, which is important to note considering the impact the electricity grid mix can have on the emissions in the use phase. The impact in other countries can differ, depending on the country's share of renewables and fossil energy sources in its local electricity grid.

The major limitation of the impact calculations for the use phase is that the electricity grid mix in use is assumed to remain at the same carbon intensity over time. Following the plans for the decarbonization of the grid across EU, the environmental impacts are expected to decrease over time within the course

Overview of LCA study

of the next 10 years. However, as decarbonization will occur in the future and as the pace of decarbonization is uncertain, the use of the emission intensity of today's grid should prove to be a "worst-case", conservative assumption.

For the purpose of this assessment, use within Finland is assumed and an average Finland CO₂ factor from LCA for Experts database (2025.2) is applied.

End-of-life (C1-C4)

The following end-of-life procedure has been applied:

- Manual dismantling is used to separate recyclable bulk materials, e.g. bulk metals and plastics.
- Shredding is used for the remaining parts, such as printed circuit board assemblies.
- Ferrous metals, non-ferrous metals and bulk plastics are recovered through recycling.
- The remaining materials go to either energy recovery or landfill.

In line with EN 15804+A2, only the 'net scrap' (i.e., the leftover recyclable materials remaining after inputs of recycled content required in the manufacturing phase are first satisfied) is used to calculate the benefits and loads beyond the system boundary (Module D).

For this EPD an average scenario with 50% of the product sent to recycling & 50% of the product sent to landfill (C3, C4, D) was used. This scenario is designed to represent an average end-of-life scenario.

For the EPD this average scenario was chosen as it is assumed that it represents the majority of cases on average.

1. Recycling scenario with 100% of the product sent to recycling at the end-of-life, excluding fractions that cannot be recycled or incinerated (e.g., glass reinforcing in glass-filled plastics) and are sent to landfill.

This scenario illustrates best case performance. It assumes a 100% collection rate and best available recycling technologies. Under this scenario electrical cables, and all metals, flat glass and unreinforced plastics found within the body and chassis of the product are recycled. Printed circuit board assemblies are incinerated, and the copper and precious metals (gold, silver, palladium, and platinum) are recycled.

2. Landfill scenario with 100% of the product sent to landfill.

This scenario assumes that the whole product, including its packaging, is landfilled. It is designed to represent a poor end-of-life-route where valuable resources are lost.

Benefits and loads beyond the system boundary (D)

Module D considers the net benefit of recycling (including energy recovery) of materials in the product and packaging, taking account of losses in the recycling process and the recycled material used in the production of the product. Module D covers the two end-of-life scenarios, as described above. It does not cover energy recovery from incineration since the process used in LCA for Experts has an efficiency below 60%. Therefore, the impacts of this process are reported in module C4 and no benefits are claimed in module D.

Environmental performance

This section presents the environmental performance of one DEVlreg™ Basic. Figure 4 presents the environmental impact of the DEVlreg™ Basic across a number of environmental impact categories (following EN 15804+A2:2019) per life cycle stage, over its full 10-year life cycle, including Global Warming Potential.

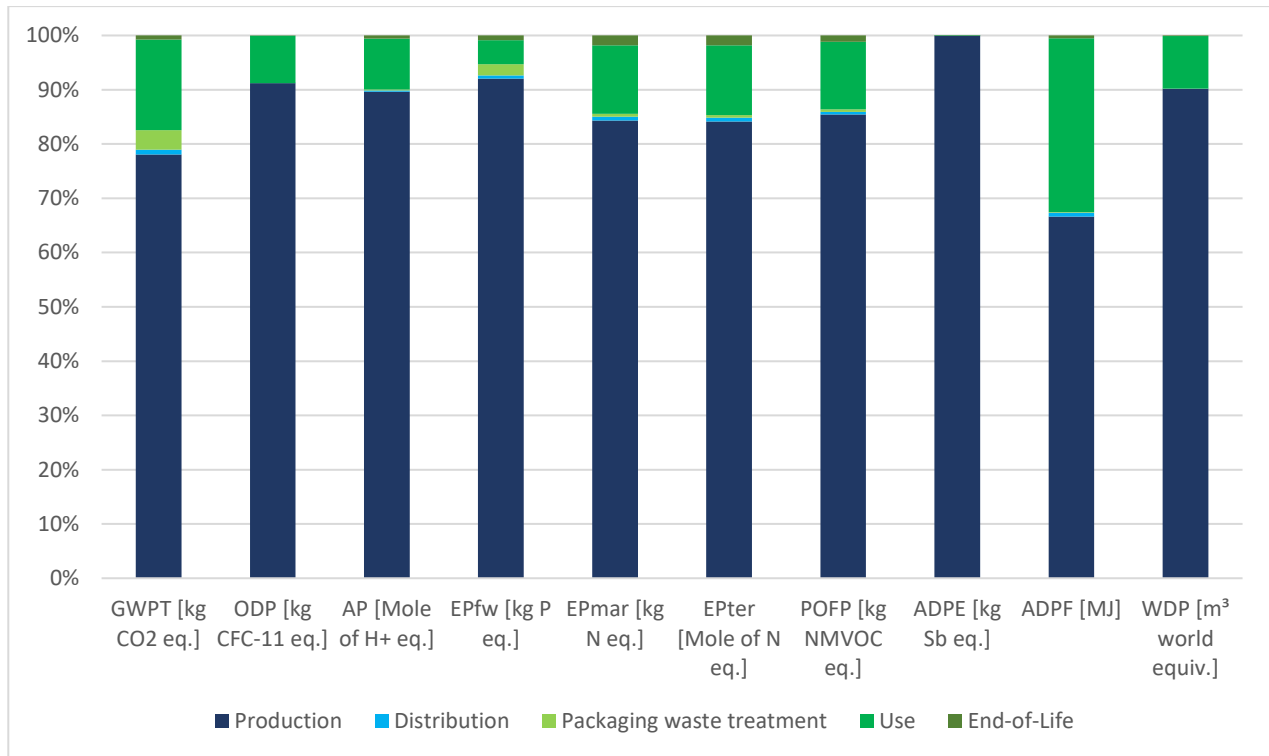

Figure 4: Breakdown of environmental impacts by life cycle stages. See Table 5 and 6 for descriptions of environmental impact indicators.

Environmental performance

Table 5: Environmental impact indicators

	Production	Distribution	Packaging waste treatment	Use	End-of-Life				(not included in Figure 4)	
Life cycle stages based on EN 15804+A2	A1-A3	A4	A5	B6	C1	C2	C3	C4	D	
Environmental Impact Indicators	Description	Manufacture of the product from 'cradle-to-gate'	Transport of the product to the customer	Installation of the product and disposal of used packaging	Use of the product over its lifetime e.g. 10 years	Deinstallation of the product from the site	Transport of the product to waste treatment	Processing waste for recycling	Disposal of waste that cannot be recycled (through landfill and incineration)	Potential benefits and loads beyond the system boundary due to reuse, recycling, and energy recovery
GWPT [kg CO2 eq.]	2,33E+00	2,68E-02	1,07E-01	4,22E-01	0,00E+00	1,41E-03	1,53E-02	5,23E-03	-9,83E-02	
GWPF [kg CO2 eq.]	2,42E+00	2,66E-02	5,97E-03	3,97E-01	0,00E+00	1,41E-03	1,51E-02	5,22E-03	-9,83E-02	
GWPB [kg CO2 eq.]	-1,01E-01	0,00E+00	1,01E-01	1,45E-02	0,00E+00	0,00E+00	0,00E+00	0,00E+00	0,00E+00	
GWPLULUC [kg CO2 eq.]	6,06E-03	2,76E-04	4,85E-06	1,12E-02	0,00E+00	3,44E-08	1,61E-04	8,72E-06	-3,94E-05	
GWP-GHG [kg CO2 eq.]	2,43E+00	2,68E-02	5,98E-03	4,08E-01	0,00E+00	1,41E-03	1,53E-02	5,23E-03	-9,83E-02	
ODP [kg CFC-11 eq.]	2,49E-11	4,45E-15	5,37E-15	2,01E-12	0,00E+00	1,66E-19	3,72E-15	5,99E-15	-8,73E-13	
AP [Mole of H+ eq.]	1,96E-02	5,13E-05	3,31E-05	1,74E-03	0,00E+00	1,99E-06	9,55E-05	2,47E-05	-1,94E-03	
EPfw [kg P eq.]	1,16E-05	7,22E-08	2,62E-07	4,72E-07	0,00E+00	3,08E-10	4,06E-08	6,63E-08	-6,13E-08	
EPmar [kg N eq.]	2,67E-03	2,20E-05	1,78E-05	3,39E-04	0,00E+00	7,74E-07	4,72E-05	8,78E-06	-1,22E-04	
EPter [Mole of N eq.]	2,87E-02	2,36E-04	1,61E-04	3,72E-03	0,00E+00	8,72E-06	5,13E-04	9,64E-05	-1,33E-03	
POFP [kg NMVOC eq.]	8,28E-03	4,64E-05	4,46E-05	1,02E-03	0,00E+00	1,84E-06	8,84E-05	2,12E-05	-4,56E-04	
ADPE [kg Sb eq.]	2,63E-04	1,78E-09	6,97E-10	5,64E-08	0,00E+00	5,07E-11	1,03E-09	1,83E-10	-2,66E-05	
ADPF [MJ]	3,35E+01	3,43E-01	8,16E-02	1,36E+01	0,00E+00	2,06E-02	2,00E-01	4,97E-02	-1,77E+00	
WDP [m ³ world equiv.]	5,61E-01	1,23E-04	2,15E-04	5,09E-02	0,00E+00	2,40E-06	9,99E-05	6,22E-04	-1,38E-02	

How to read scientific numbers:

e.g. 2,05E02 = 2,05 x 10² = 205

2,04E-01 = 2,04 x 10⁻¹ = 0,204

Environmental performance

Table 6: Environmental impact indicator descriptions

Acronym	Unit	Indicator
GWPT	kg CO ₂ eq.	Carbon footprint (Global Warming Potential) – total
GWPF	kg CO ₂ eq.	Carbon footprint (Global Warming Potential) – fossil
GWPB	kg CO ₂ eq.	Carbon footprint (Global Warming Potential) – biogenic
GWPLULUC	kg CO ₂ eq.	Carbon footprint (Global Warming Potential) – land use and land use change
ODP	kg CFC-11 eq.	Depletion potential of the stratospheric ozone layer
AP	Mole H ⁺ eq.	Acidification potential
EPfw	kg P eq.	Eutrophication potential – aquatic freshwater
EPmar	kg N eq.	Eutrophication potential – aquatic marine
EPter	Mole of N eq.	Eutrophication potential – terrestrial
POFP	kg NMVOC eq.	Summer smog (photochemical ozone formation potential)
ADPE*	kg Sb eq.	Depletion of abiotic resources – minerals and metals
ADPF*	MJ	Depletion of abiotic resources – fossil fuels
WDP*	m ³ world eq.	Water deprivation potential (deprivation-weighted water consumption)

Results for module A1-A3 are specific to the product. All results from module A4 onwards should be considered as scenarios that represent one possible outcome. The true environmental performance of the product will depend on actual use.

The results in this section are relative expressions only and do not predict actual impacts, the exceeding of thresholds, safety margins, or risks. EPDs from others may not be comparable.

Carbon footprint

The total carbon footprint (GWPT), cradle-to-grave, of the product is **2,91E+00 kg CO₂-eq (A1-C4)**, based on the baseline use phase scenario. The carbon footprint of production of this product, cradle-to-gate, is **2,33E+00 kg CO₂-eq (A1-A3)**.

Environmental performance

Table 7: Resource use

	A1-A3	A4	A5	B6	C1	C2	C3	C4	D
PERE [MJ]	9,89E+00	2,59E-02	5,58E-03	1,01E+01	0,00E+00	6,77E-05	2,07E-02	5,72E-03	-1,36E-01
PERM [MJ]	0,00E+00	0,00E+00	0,00E+00	0,00E+00	0,00E+00	0,00E+00	0,00E+00	0,00E+00	0,00E+00
PERT [MJ]	9,89E+00	2,59E-02	5,58E-03	1,01E+01	0,00E+00	6,77E-05	2,07E-02	5,72E-03	-1,36E-01
PENRE [MJ]	3,12E+01	3,43E-01	8,16E-02	1,36E+01	0,00E+00	2,06E-02	2,00E-01	4,97E-02	-1,77E+00
PENRM [MJ]	2,28E+00	0,00E+00	0,00E+00	0,00E+00	0,00E+00	0,00E+00	0,00E+00	0,00E+00	0,00E+00
PENRT [MJ]	3,35E+01	3,43E-01	8,16E-02	1,36E+01	0,00E+00	2,06E-02	2,00E-01	4,97E-02	-1,77E+00
SM [kg]	4,25E-02	0,00E+00	0,00E+00	0,00E+00	0,00E+00	0,00E+00	0,00E+00	0,00E+00	0,00E+00
RSF [MJ]	0,00E+00	0,00E+00	0,00E+00	0,00E+00	0,00E+00	0,00E+00	0,00E+00	0,00E+00	0,00E+00
NRSF [MJ]	0,00E+00	0,00E+00	0,00E+00	0,00E+00	0,00E+00	0,00E+00	0,00E+00	0,00E+00	0,00E+00
FW [m3]	1,85E-02	1,28E-05	6,95E-06	1,10E-02	0,00E+00	1,09E-07	1,39E-05	1,60E-05	-4,62E-04

Table 8: Resource use indicator descriptions

Acronym	Unit	Indicator
PERE	MJ	Use of renewable primary energy excluding renewable primary energy resources used as raw materials
PERM	MJ	Use of renewable primary energy resources used as raw materials
PERT	MJ	Total use of renewable primary energy resources (primary energy and primary energy resources used as raw materials)
PENRE	MJ	Use of non-renewable primary energy excluding non-renewable primary energy resources used as raw materials
PENRM	MJ	Use of non-renewable primary energy resources used as raw materials
PENRT	MJ	Total use of non-renewable primary energy resources (primary energy and primary energy resources used as raw materials)
SM	kg	Use of secondary material
RSF	MJ	Use of renewable secondary fuels
NRSF	MJ	Use of non-renewable secondary fuels
FW	m ³	Net use of fresh water

Environmental performance

Table 9: Waste categories and output flows

	A1-A3	A4	A5	B6	C1	C2	C3	C4	D
HWD [kg]	3,23E-08	1,38E-11	1,35E-11	1,45E-08	0,00E+00	1,41E-13	1,67E-11	6,99E-12	1,94E-09
NHWD [kg]	1,11E-01	4,79E-05	2,36E-02	1,24E-02	0,00E+00	2,06E-06	3,44E-05	1,32E-01	-6,72E-03
RWD [kg]	8,31E-04	6,48E-07	5,61E-07	3,31E-03	0,00E+00	2,20E-08	2,41E-06	3,88E-07	-9,37E-06
CRU [kg]	0,00E+00	0,00E+00	0,00E+00	0,00E+00	0,00E+00	0,00E+00	0,00E+00	0,00E+00	0,00E+00
MFR [kg]	0,00E+00	0,00E+00	0,00E+00	0,00E+00	0,00E+00	0,00E+00	0,00E+00	1,30E-01	0,00E+00
MER [kg]	0,00E+00	0,00E+00	0,00E+00	0,00E+00	0,00E+00	0,00E+00	0,00E+00	0,00E+00	0,00E+00
EEE [MJ]	0,00E+00	0,00E+00	0,00E+00	0,00E+00	0,00E+00	0,00E+00	0,00E+00	0,00E+00	0,00E+00
EET [MJ]	0,00E+00	0,00E+00	0,00E+00	0,00E+00	0,00E+00	0,00E+00	0,00E+00	0,00E+00	0,00E+00

Table 10: Waste category and output flow descriptions

Acronym	Unit	Indicator
HWD	kg	Hazardous waste disposed
NHWD	kg	Non-hazardous waste disposed
RWD	kg	Radioactive waste disposed
CRU	kg	Components for reuse
MFR	kg	Materials for recycling
MER	kg	Materials for energy recovery
EEE	kg	Exported energy (electrical)
EET	kg	Exported energy (thermal)

Environmental performance

Table 11: Additional indicators*

	A1-A3	A4	A5	B6	C1	C2	C3	C4	D
PM [Disease incidences]	2,11E-07	4,37E-10	2,42E-10	1,74E-08	0,00E+00	1,18E-11	6,32E-10	2,46E-10	-1,65E-08
IRP [kBq U235 eq.]	8,44E-02	9,31E-05	7,33E-05	3,29E-01	0,00E+00	3,12E-06	2,56E-04	4,67E-05	-2,30E-04
ETPfw [CTUe]	2,11E+01	4,46E-01	6,09E-02	8,74E-01	0,00E+00	1,51E-02	2,50E-01	4,05E-02	-1,39E+00
HTPc [CTUh]	6,86E-10	6,02E-12	1,07E-12	2,24E-10	0,00E+00	2,77E-13	3,50E-12	7,82E-13	-3,56E-11
HTPnc [CTUh]	2,60E-08	3,37E-10	7,57E-11	2,77E-09	0,00E+00	9,06E-12	1,90E-10	2,91E-11	-9,69E-10
SQP [Pt]	9,48E+00	1,52E-01	1,02E-02	1,04E+01	0,00E+00	5,26E-05	9,11E-02	7,10E-03	-1,29E-01

Table 12: Optional indicator descriptions

Acronym	Unit	Indicator
PM	Disease incidence	Potential incidence of disease due to particulate matter emissions
IRP**	kBq U235 eq.	Potential human exposure efficiency relative to U235
ETPfw*	CTUe	Potential Comparative Toxic Unit for ecosystems (fresh water)
HTPc*	CTUh	Potential Comparative Toxic Unit for humans (cancer)
HTPnc*	CTUh	Potential Comparative Toxic Unit for humans (non-cancer)
SQP*	Dimensionless	Potential soil quality index

*Disclaimer for ADPE, ADPF, WDP, ETPfw, HTPc, HTPnc, SQP: The results of these environmental impact indicators shall be used with care as the uncertainties on these results are high or as there is limited experienced with the indicator.

**Disclaimer for ionizing radiation: This impact category deals mainly with the eventual impact of low dose ionizing radiation on human health of the nuclear fuel cycle. It does not consider effects due to possible nuclear accidents, occupational exposure nor due to radioactive waste disposal in underground facilities. Potential ionizing radiation from the soil, from radon and from some construction materials is also not measured by this indicator.

References

- CEN (2015). *EN 50598-3:2015: Ecodesign for power drive systems, motor starters, power electronics and their driven applications – Part 3: Quantitative eco design approach through life cycle assessment including product category rules and the content of environmental declarations*. Brussels, Belgium: European Committee for Standardization.
- CEN (2019). *EN 15804:2012+A2:2019: Sustainability of construction works – Environmental product declarations – Core rules for the product category of construction products*. Brussels, Belgium: European Committee for Standardization.
- Danfoss (2022). *Danfoss Product Category Rules: Environmental Product Declarations for Danfoss Products*. Nordborg, Denmark: Danfoss A/S.
- ISO (2006a). *ISO 14025:2006: Environmental labels and declarations – Type III environmental declarations – Principles and procedures*. Geneva, Switzerland: International Organization for Standardization.
- ISO (2006b). *ISO 14040:2006: Environmental management – Life cycle assessment – Principles and framework*. Geneva, Switzerland: International Organization for Standardization.
- ISO (2006c). *ISO 14044:2006: Environmental management – Life cycle assessment – Requirements and guidelines*. Geneva, Switzerland: International Organization for Standardization.

Danfoss Climate Solutions

Any information, including, but not limited to information on selection of product, its application or use, product design, weight, dimensions, capacity or any other technical data in product manuals, catalogues descriptions, advertisements, etc. and whether made available in writing, orally, electronically, online or via download, shall be considered informative, and is only binding if and to the extent, explicit reference is made in a quotation or order confirmation. Danfoss cannot accept any responsibility for possible errors in catalogues, brochures, videos and other material. Danfoss reserves the right to alter its products without notice. This also applies to products ordered but not delivered provided that such alterations can be made without changes to form, fit or function of the product. All trademarks in this material are property of Danfoss A/S or Danfoss group companies. Danfoss and the Danfoss logo are trademarks of Danfoss A/S. All rights reserved.
