

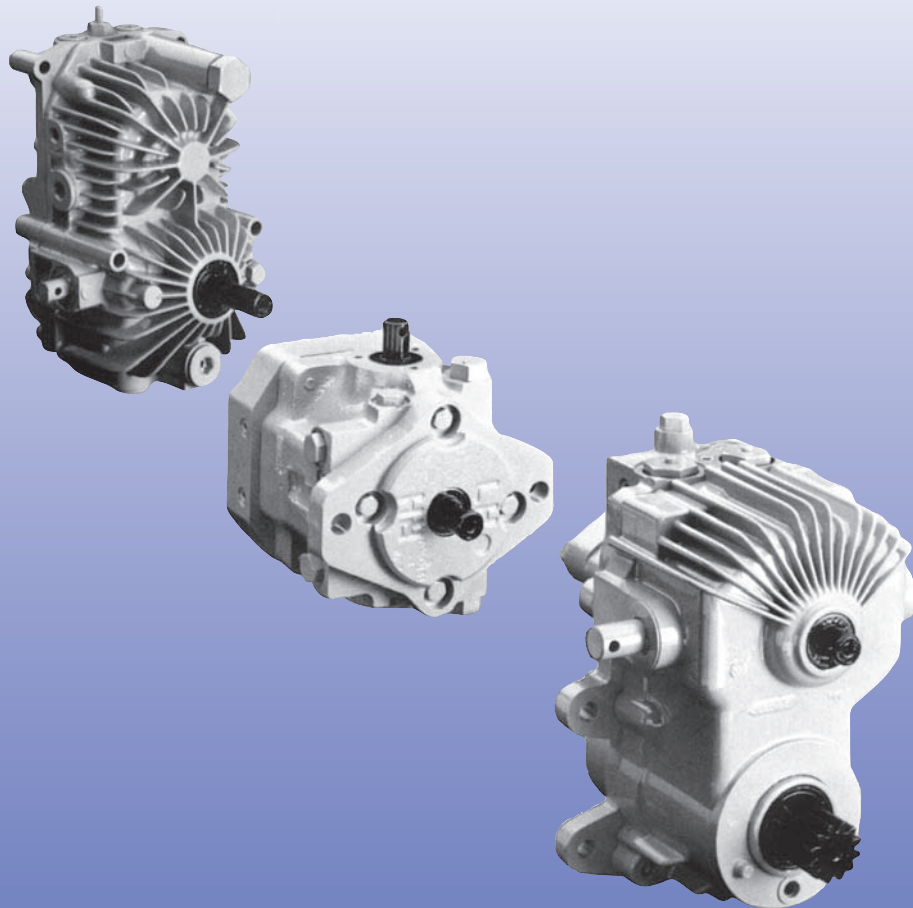

---

## Series 70 / 15 Series

---



---

**Axial Piston**

---

**Pumps, Motors**

---

**and Transmissions**

---

**Technical Information**

---

**Series 70 Transmissions and Pumps**

---

- 2 Transmission Frame Sizes: 10 and 21
- Variable Pump Version of 10 Frame Size Available
- Cost Effective, Compact Design
- Low Noise
- High Efficiency
- Worldwide Sales and Service



**15 Series Pumps, Motors, and Transmissions**

---

- Proven Reliability and Performance
- Variable Pumps, Tandem Pumps, and Fixed Motors Available
- Two Transmission Configurations: “In-line” and “U” Style
- PTO Capability on “U” Style Transmission
- Compact, Lightweight Design
- Worldwide Sales and Service

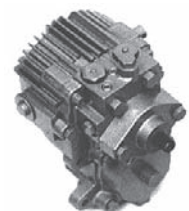
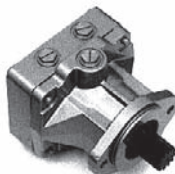
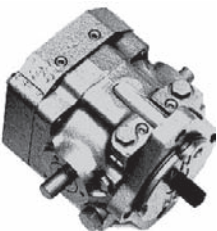

## Series 70 Transmissions and Pumps

---

### A Complete Transmission Family to Meet the Needs of the Lawn and Turf Equipment Market

---

- Two (2) Different Sizes -  
.61 in<sup>3</sup>/Rev. (10 cc/rev)  
1.28 in<sup>3</sup>/Rev. (21 cc/rev)
- “U” Style Transmissions and Variable Displacement Pump (10 Size Only)
- Closed Circuit Installations

### High Performance

---

- High Efficiency
- Low Noise Levels

### Advanced Technology

---

- Compact, Lightweight Design
- Designed for Economical Manufacturing
- Design Provides for Reduced Operating Costs
- Direct Displacement Control

### Reliability and Support

---

- Designed and Tested to Rigorous Standards
- Proven in Laboratory and Field
- Sales and Technical Support in All Industrialized Countries of the World
- Serviced by a Worldwide Network of Authorized Service Centers

## 15 Series Pumps, Motors, and Transmissions

---

### A Complete Transmission Family to Meet the Needs of the Utility, Construction, and Commercial Turf Maintenance Equipment Markets

---

- Displacement - .913 in<sup>3</sup>/Rev. (15 cc/rev)
- Variable Displacement Pumps, Tandem Pumps, and Fixed and Variable Motors
- “U” Style and “In-line” Transmissions
- Wide Range of Installation Options

### High Performance

---

- High Efficiency
- Low Noise Levels

### Proven Technology

---

- Compact Design
- Designed for Economical Manufacturing
- Direct Displacement Control
- Designed to Worldwide Standards

### Reliability and Support

---

- Manufactured to Rigid Quality Standards
- Long Service Life
- Sales and Technical Support in All Industrialized Countries of the World
- Serviced by a Worldwide Network of Authorized Service Centers

**Contents**

---

<b>Description</b>	<b>Page</b>
<b>General Description</b> .....	2
<b>Technical Features</b> .....	3
<b>Product Configurations</b> .....	5
<b>Technical Specifications - Series 70 Products</b> .....	6
<b>Technical Specifications - 15 Series Products</b> .....	7
<b>Type Designation and Order Code</b> .....	8
Series 70 Model Code .....	8
15 Series Typical Models .....	9
<b>Description of Operation for Series 70 and 15 Series Products</b> .....	10
Basic Pump/Motor Circuit, Variable Displacement Pump, Fixed Displacement Motor, Direct Displacement Control .....	10
Charge Pump, Inlet filter, Bypass Valve .....	11
Implement Circuit .....	12
Easy-Ride Valves .....	13
<b>General Technical Specifications - Series 70 and 15 Series Products</b> .....	15
Speed Ratings, Pressure Limits, Fluids, Filtration, Reservoir Requirements, Case Pressure .....	15
Temperature and Cooling, Auxiliary Mounting Pad (15PV), Mounting Flange Loads (15PT), Allowable Shaft Side Loads .....	16
Direct Displacement Control (DDC), Implement Pump Performance, Braking Warning .....	17
Efficiency and Performance of Series 70 Units .....	18
Efficiency and Performance of 15 Series Units .....	19
<b>Definitions of Typical Lawn Care and Turf Maintenance Vehicles</b> .....	20
<b>Component Selection for Lawn Care and Turf Maintenance Vehicles</b> .....	20
<b>Installation Drawings</b> .....	22
Dimensions • BDU-10S and BDU-10L Transmissions .....	22
Dimensions • BDP-10L Variable Displacement Pump .....	23
Dimensions • BDU-21L Transmission .....	24
Dimensions • 15 Series Variable Displacement Pump • 15 PV .....	25
Dimensions • 15 Series Variable Displacement Tandem Pump • 15 PT .....	27
Dimensions • 15 Series Fixed Displacement Motor • 15 MF .....	28
Dimensions • 15 Series In-line Transmission .....	29
Dimensions • 15 Series “U” Style Transmission • 15U .....	30

## Series 70 / 15 Series - Configuration

### Series 70 Units

Series 70 units are of axial piston design, utilizing spherical nosed pistons. All Series 70 variable pumps feature cradle washplates with direct displacement control.

- The BDU-10L transmission is a “U” style transmission designed for machine applications where up to 6 horsepower is required for the propel function. The variable displacement pump has a maximum displacement of 0.61 in<sup>3</sup>/Rev. (10 cc/Rev), and the fixed displacement motor has a displacement of 0.61 in<sup>3</sup>/Rev. (10 cc/Rev.).
- The BDU-21L transmission is a “U” style transmission designed for vehicle applications where up to 12 horsepower is required for the propel function. The variable displacement pump has a maximum displacement of 1.28 in<sup>3</sup>/Rev. (21 cc/Rev), and the fixed displacement motor has a displacement of 1.28 in<sup>3</sup>/Rev. (21 cc/Rev).
- The BDP-10L is a variable displacement pump designed for vehicle applications where up to 6 horsepower is required for the propel function, or for auxiliary functions where the system pressure requirements and design life can be met within the pump rating. This variable displacement pump has a maximum displacement of 0.61 in<sup>3</sup>/Rev. (10 cc/Rev).



### 15 Series Units

15 Series units are of axial piston design, utilizing slipper pistons. All 15 Series variable pumps feature trunnion style washplates with direct displacement control.

- The 15 Series transmission is offered in two configurations; a “U” style and an in-line style. These units are designed for machine applications where up to 15 horsepower is required for the propel function. The variable displacement pump has a maximum displacement of 0.913 in<sup>3</sup>/Rev. (15 cc/Rev.), and the fixed displacement motor has a displacement of 0.913 in<sup>3</sup>/Rev. (15 cc/Rev.).
- The 15 Series variable displacement pump is designed for machine applications where up to 15 horsepower is required for the propel function, or for auxiliary work functions where the system pressure requirements and the design life can be met within the pump rating. The maximum pump displacement is 0.913 in<sup>3</sup>/Rev. (15 cc/Rev.).
- The 15 Series fixed displacement motor is an axial piston unit with a fixed displacement of 0.913 in<sup>3</sup>/Rev. (15 cc/Rev.). The variable displacement motor has a maximum displacement of 0.913 in<sup>3</sup>/Rev. (15 cc/Rev.).

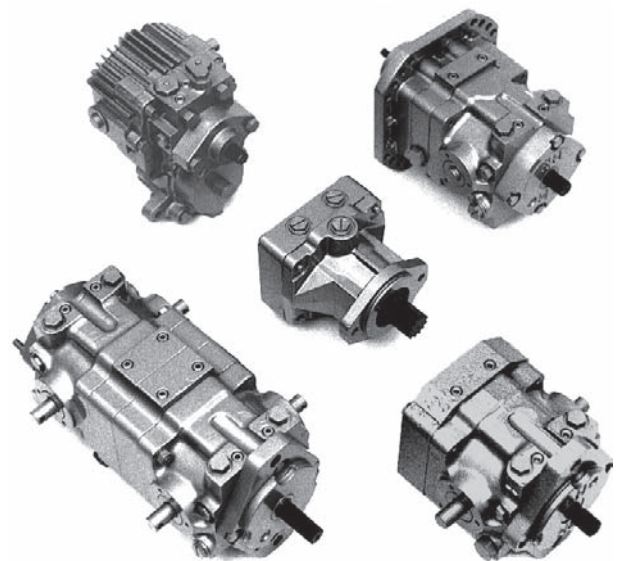

**Technical Specifications - Series 70 Products**

Product Type	"U" Style Transmissions			Variable Pump BDP-10L		
	BDU-10S	BDU-10L	BDU-21L			
<b>Displacement</b> Variable Pump (Maximum)	in <sup>3</sup> /Rev	0.61	0.61	1.28	0.61	
	cc/Rev	10	10	21	10	
	Fixed Motor	in <sup>3</sup> /Rev	0.61	0.61	1.28	DNA
		cc/Rev	10	10	21	DNA
<b>Input Speeds</b>	Maximum Hi-Idle - rpm	3000	3600	3600	3600	
	Maximum Loaded - rpm	3000	3600	3200	3600	
	Minimum (Pump) - rpm	1800	1800	1800	1800	
<b>System Operating Pressure</b>	Maximum	2100	2100	2100	2100	
	psi					
	bar	145	145	145	145	
	Continuous	850	1000	1000	1000	
psi						
bar	60	70	70	70		
<b>Case Pressure</b>	Continuous	psi	} ————— ALL UNITS —————>			
		bar				4
	Maximum (Cold Start)	psi				0.3
		bar				10
Weight	lbs	15	15	23	10	
	kg	6.8	6.8	10	4.5	
<b>Charge Pump Displacement</b>	in <sup>3</sup> /Rev	DNA	0.11	0.13	0.11	
	cc/Rev		1.9	2.1	1.9	
<b>Motor Output Torque (Approximate)</b>	lbf•in / 1000 psi	85	85	180	DNA	
	Nm / 100 bar	14	14	30		
<b>Control Torque Required to Stroke Pump (Approximate)</b>	lbf•in / 1000 psi	65	65	100	65	
	Nm / 70 bar	7.3	7.3	11.3	7.3	
<b>Transmission Oil Temperature</b>	Maximum Intermittent	° F	} ————— ALL UNITS —————>			
		° C				220
	Normal Operating Range	° F				-30 to 180
		° C				
<b>Fluid Viscosity Limits — SUS (mm<sup>2</sup>/sec)</b>	Optimum	70 (13)	} ————— ALL UNITS —————>			
	Minimum Continuous	55 (9.0)				
	Minimum Intermittent	45 (6.0)				

DNA = Does Not Apply

**Technical Specifications - 15 Series Products**

Product Type	Transmissions		Variable Pump 15 PV	Tandem Pump 15 PT	Fixed Motor 15 MF		
	15 "U"	15 In-line					
<b>Displacement</b> Variable Pump (Maximum)	in <sup>3</sup> /Rev	0.913	0.913	0.913	0.913 X 2	DNA	
	cc/Rev	15	15	15	15 X 2		
Fixed Motor	in <sup>3</sup> /Rev	0.913	0.913	DNA	DNA	0.913	
	cc/Rev	15	15				15
<b>Shaft Speeds</b>	Maximum - rpm	4200	4200	4200	4200	4200	
	Continuous - rpm	4000	4000	4000	4000	4000	
	Minimum (Pump) - rpm	1000	1000	1000	1000	DNA	
<b>System Operating Pressure</b>	Maximum *	psi	} ALL 15 SERIES UNITS →	}	}	}	
		bar					4500
	Continuous *	psi					310
		bar					2500
<b>Case Pressure</b>	Continuous	psi	} ALL 15 SERIES UNITS →	}	}	}	
		bar					10
	Maximum (Cold Start)	psi					0.7
		bar					25
<b>Weight</b>	lbs	33	37	32	64	15	
	kg	15.0	16.5	14.5	29.0	6.5	
<b>Charge Pump Displacement</b>	in <sup>3</sup> /Rev	0.30	0.33	0.33	0.33 X 2	DNA	
	cc/Rev	4.9	5.4	5.4	5.4 X 2		
<b>Motor Output Torque (Approximate)</b>	lbf•in / 1000 psi	135	135	DNA	DNA	135	
	Nm / 100 bar	21	21			21	
<b>Control Torque Required to Stroke Pump (Approximate)</b>	lbf•in / 1000 psi	65	} ALL 15 SERIES PUMPS →	}	}	DNA	
	Nm / 70 bar	7.3					
Maximum torque on control shaft must not exceed 400 lbf•in (45.2 Nm). Maximum radial force on control shaft must not exceed 100 lbf (445 N), applied 3 in (76.2 mm) from seal surface.							
<b>Transmission Oil Temperature</b>	Maximum Intermittent	° F	} ALL 15 SERIES UNITS →	}	}	}	
		° C					220
	Normal Operating Range	° F					104
		° C					-30 to 180
<b>Fluid Viscosity Limits — SUS (mm<sup>2</sup>/sec)</b>	Optimum	° F	} ALL 15 SERIES UNITS →	}	}	}	
		° C					-34 to 82
	Minimum Continuous	° F					70 (13)
		° C					55 (9.0)
Minimum Intermittent	° F	45 (6.0)					
	° C						

DNA = Does Not Apply

\* = Refer to text for unit life relationship

**Series 70 Type Designation and Order Code**

**BDU Transmissions and BDP Pumps**

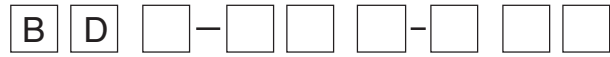

**PRODUCT OR SERIES** \_\_\_\_\_

BD = Bantam Duty Transmission or Variable Pump

**1. CONFIGURATION** \_\_\_\_\_

U = Transmission

P = Pump - Variable (10 cc/Rev., Charge Pump Std.)

**2. DISPLACEMENT** \_\_\_\_\_

10 = 10 cc/Rev (0.61 in<sup>3</sup>/Rev.)

21 = 21 cc/Rev (1.28 in<sup>3</sup>/Rev.) (Charge Pump Std.)

**3. STYLE** \_\_\_\_\_

S = Standard, 3000 rpm Maximum Input Speed (No Charge Pump)

L = With Charge Pump, 3600 rpm Maximum Input Speed

**4. CONTROL LOCATION** \_\_\_\_\_

1 = Left Hand Side

2 = Right Hand Side

3 = Left Hand Side w/Auxiliary Pump (3 cc/Rev.)

**5. OPTIONS**

	Input Shaft Rotation	Shaft Styles		Other
		Pump	Motor	
BDU-10S-1 14	Both	36T, 12.319 PD Spline	36T, 12.319 PD Spline	Fits Hydro-Gear 210-1000 Axle Motor Shaft suitable for Indirect Drive Motor Shaft suitable for Indirect Drive Fits Hydro-Gear 210-1000 Axle
BDU-10S-1 15	Both	15 mm dia., Straight Key	16T 32/64P Spline	
BDU-10S-2 13	Both	15 mm dia., Straight Key	16T 32/64P Spline	
BDU-10S-2 14	Both	36T, 12.319 PD Spline	36T, 12.319 PD Spline	
BDU-10L-1 10	LH	15 mm dia., Straight Key	16T 32/64P Spline	Fits Hydro-Gear 210-2500 Axle Motor Shaft suitable for Indirect Drive Motor Shaft suitable for Indirect Drive Fits Hydro-Gear 210-2500 Axle
BDU-10L-1 11	RH	15 mm dia., Straight Key	16T 32/64P Spline	
BDU-10L-2 10	LH	15 mm dia., Straight Key	16T 32/64P Spline	
BDU-10L-2 11	RH	15 mm dia., Straight Key	16T 32/64P Spline	
BDP-10L-1 10	RH	15 mm dia., Straight Key	N/A	
BDP-10L-1 11	LH	15 mm dia., Straight Key	N/A	
BDP-10L-1 12	RH	9T 16/32P Spline	N/A	
BDP-10L-1 13	LH	9T 16/32P Spline	N/A	
BDU-21L-1 10	LH	17 mm dia., Straight Key	22T 32/64P Spline	Easy-Ride Valves (2) Fits Hydro-Gear 210-3000 Axle
BDU-21L-2 00	RH	17 mm dia., Straight Key	22T 32/64P Spline	
BDU-21L-2 02	RH	17 mm dia., Straight Key	22T 32/64P Spline	
BDU-21L-2 03	RH	17 mm dia., Straight Key	22T 32/64P Spline	
BDU-21L-3 00	RH	17 mm dia., Straight Key	22T 32/64P Spline	
BDU-21L-3 10	LH	17 mm dia., Straight Key	22T 32/64P Spline	

N/A = Not Applicable



**15 Series Typical Models Incorporating Standard Options**

---

**15 PV**

Model Number	Pump Rot	Pump Shaft	Control Side	Comments
15-2125	CW	Straight, Sq Key (E)	R	
15-2133	CCW	17T Spline, Tapped (J)	R	
15-2158	CCW	Straight, Wdrf Key (A)	L	7/8-14 Inlet

**15 MF**

Model Number	Motor Shaft	Comments
15-3022	24T Spline (B)	Mates with Dana GT-20 Axle (20.9:1)
15-3034	12T Gear (G)	Mates with Dana GT-20 Axle (30:1)
15-3043	12T Spline	Mates With Peerless 2500 Axle
15-3045	17T Spline	Mates With Peerless 2600 Axle

**15 U**

Model Number	Pump Rot	Pump Shaft	Motor Shaft	Control Side	Comments
90-1219	CW	.625/.625 Pin (A)	12T Gear (B)	L	Mates with Dana GT-20 Axle (30:1)
90-1252	CCW	.625/.750 Strt Key (D)	16T Gear (D)	R	Mates with Dana GT-20 Axle (20.9:1)
90-1267	CCW	21T/17T Spline (G)	17T Spline (E)	L	Mates With Peerless 2600 Axle

**15 In-line**

Model Number	Pump Rot	Pump Shaft	Motor Shaft	Control Side	Comments
90-1303	CCW	Straight, Wdrf Key	17T Spline	R	Mates with Dana GT-20 Axle (20.9:1)

NOTE: Contact Sauer-Sundstrand for information on other available models.

## Description of Operation for Series 70 and 15 Series Products

### Basic Pump/Motor Circuit

A typical hydrostatic transmission consists of a variable displacement axial piston pump connected in closed circuit to a fixed displacement axial piston motor. There are two basic arrangements of hydrostatic transmissions:

1. A split system in which the pump and motor are mounted separately. Pressurized fluid is contained and directed through hoses or tubing.
2. An integral system in which the pump and motor are contained in the same housing with pressurized fluid internally contained.

The variable pump (PV) is driven by a prime mover, typically an internal combustion engine. The fixed motor (MF) drives the vehicle transmission or other work function. Direction of rotation and speed of the motor shaft depends on the output flow of the pump. System pressure is dependent upon vehicle tractive resistance or other work function requirements.

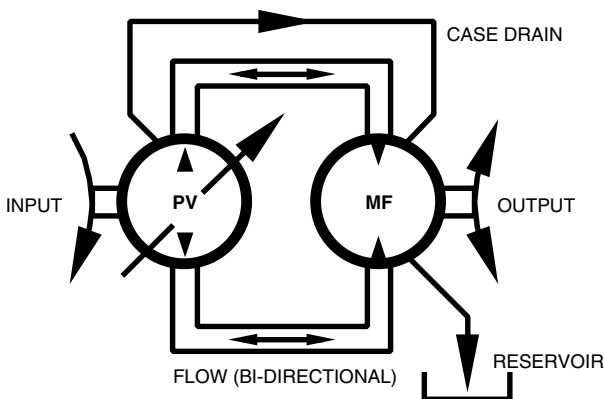

### Basic Closed Circuit

### Variable Displacement Pump

The variable displacement pump (PV) is an axial piston design. It has a mechanical control connected to the swashplate. In operation, as the machine operator moves the control handle, the swashplate tilts. This tilting results in fluid flow from the pump, with the amount of fluid flow being proportional to the swashplate tilt angle. The direction in which fluid is pumped depends on input rotation and the side of neutral that the swashplate is tilted or stroked. Reversing the swashplate angle reverses the flow of fluid.

### Fixed Displacement Motor

The fixed displacement motor (MF) is an axial piston motor that has the swashplate at a fixed angle, giving it a fixed displacement. The direction of motor shaft rotation depends on the direction of fluid flow through the motor. Changing the direction of fluid flow through the motor causes opposite motor shaft rotation.

### Direct Displacement Control

The variable displacement pump swashplate in both the Series 70 and 15 Series transmissions is directly controlled. For the Series 70 pump, any movement of the control shaft results in a proportional movement of the swashplate, with 21 degrees of control rotation resulting in 15 degrees of swashplate rotation. For the 15 Series pump, any movement of the control shaft results in equivalent swashplate movement, with 15 degrees of control shaft rotation resulting in 15 degrees of swashplate rotation.

Description of Operation for Series 70 and 15 Series Products (Continued)

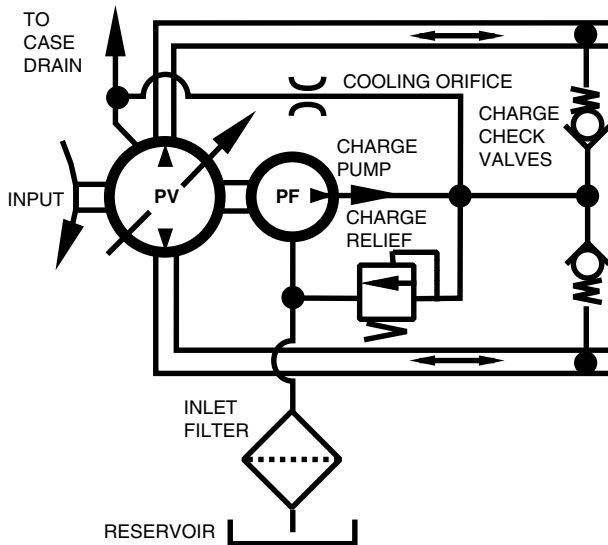

Charge Circuit – Series 70-BD

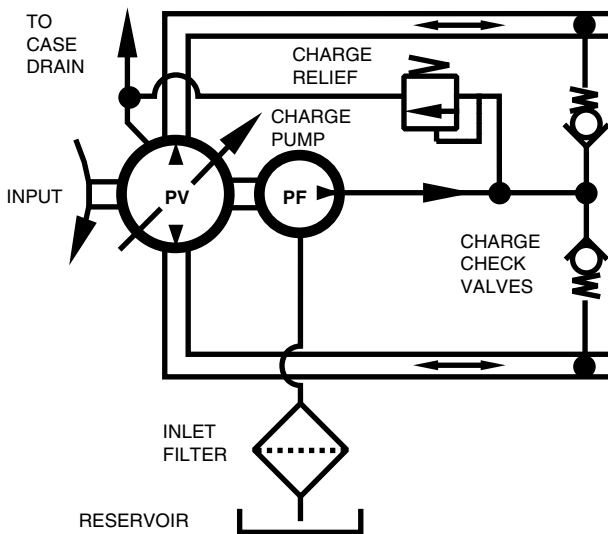

Charge Circuit – 15 Series

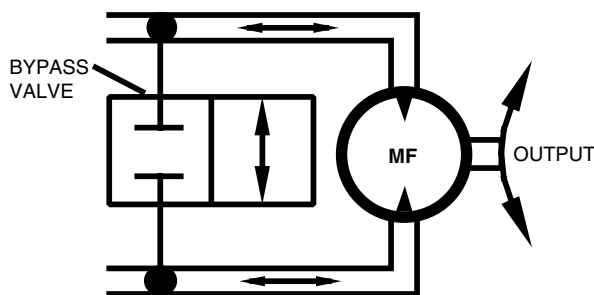

Bypass Valve Circuit

**Charge Pump**

Axial piston pumps and motors use a small amount of fluid for internal lubrication. This results in fluid being lost from the closed circuit that must be replenished. A fixed displacement gerotor pump is used to replenish the lost oil. This gerotor pump, called a charge pump, is driven by the prime mover through the piston pump drive shaft.

Since the piston pump and piston motor are connected in a closed circuit, either side of the hydrostatic loop may be pressurized. To allow charge oil to enter the closed circuit, two check valves are used to direct charge flow to the side of the loop with the lowest pressure.

The pressure in the charge pump circuit is limited by a direct operating relief valve. Any fluid not used as replenishing oil is discharged over this valve, either into the transmission case or recirculated back to the charge pump inlet. Flow across a small fixed orifice connecting the charge circuit with the transmission housing, supplements the cooling flow in the Series 70 transmissions.

**Inlet Filter**

It is imperative that only clean fluid enters the hydrostatic transmission circuit, therefore a 20 micron (nominal rating) inlet filter is required in the charge pump inlet line. This filter should not have a bypass and should be changed regularly to ensure system reliability.

**Bypass Valve**

In some applications, it is desirable to move the machine for short distances at low speeds without starting the engine. A bypass valve allows oil to be routed from one side of the pump/motor circuit to the other, thus allowing the motor to turn. The bypass valve must be fully closed during normal vehicle operation.

Series 70 BDU-10L and 21L transmissions utilize a spool type bypass valve. A spring closes this valve on the 10L transmission, while charge pressure closes the valve on the 21L transmission. The BDP-10L pump utilizes a screw type bypass valve.

15 Series PV, PT, and in-line units utilize a screw type bypass valve which is fully open at 1/2 revolution of the valve stem. 15 Series U transmissions utilize the charge check valves for the bypass function. External plungers are depressed to hold the charge check balls off of their seats, allowing oil to bypass from one side of the pump/motor circuit to the other.

Description of Operation for Series 70 and 15 Series Products (Continued)

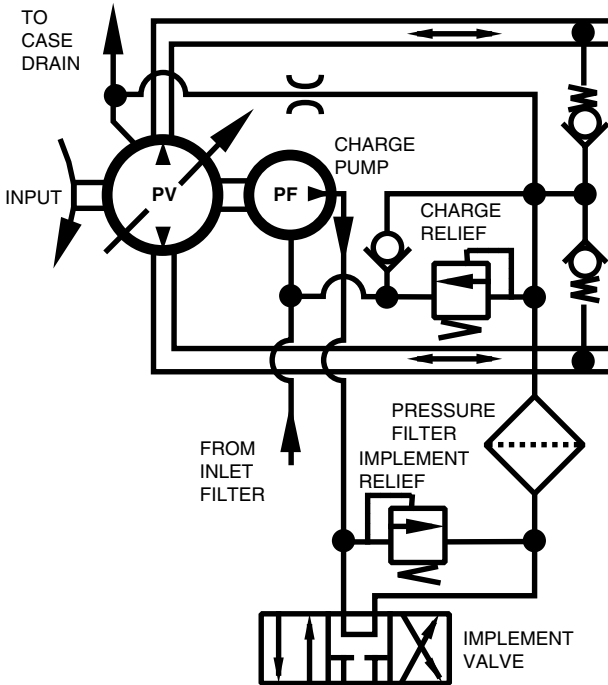

Implement Circuit – Series 70-BDU-21L

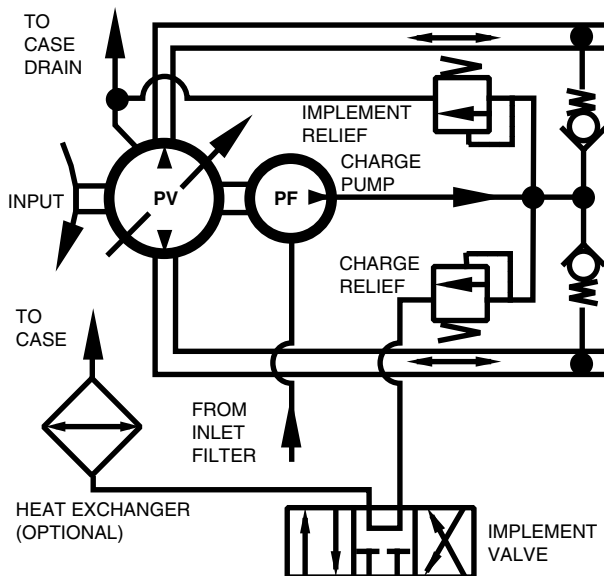

Implement Circuit – 15 Series

**Implement Pump**

Implement (auxiliary) flow capability is offered on the Series 70 21 cc transmission and on 15 Series units. Charge (implement) pump sizes available are .18 in<sup>3</sup>/Rev. (3 cc/rev.) for the Series 70 BDU-21L transmission, .30 in<sup>3</sup>/Rev. (4.9 cc/rev.) for the 15 U transmission and .33 in<sup>3</sup>/Rev. (5.4 cc/rev.) for the 15 PV, 15 PT, or 15 in-line transmission.

The implement circuit must be of the “open center” type that allows oil from the charge pump circulating through the control valve to return to the transmission.

There are two styles of implement circuits depending upon whether the Series 70 or the 15 Series is used.

In the Series 70 BDU-21 implement circuit, flow from the charge (implement) pump flows first to the implement circuit control valve, then to the charge relief and charge check valves. The implement circuit **must** be designed to return the implement flow to the transmission. (A check valve is provided to allow oil to be drawn into the charge circuit should the flow returning from the implement circuit be momentarily insufficient to charge the closed loop.) The customer must provide an implement circuit relief valve in addition to the implement control valve. It is also recommended that the customer provide a charge pressure filter between the implement control valve and the transmission to prevent any contaminants created in the implement circuit actuator(s) from entering the charge circuit.

In the 15 Series implement circuit, flow from the charge (implement) pump flows to the charge check valves and charge relief. Once charge pressure is established, the charge relief allows oil to flow to the implement control valve, and on to the transmission case drain. (If an oil cooler is required in the circuit, it may be installed between the implement control valve and the case connection.) The implement relief valve limits the pressure in the implement circuit (and charge circuit) when the implement valve is actuated.

**Description of Operation for Series 70 and 15 Series Products (Continued)**

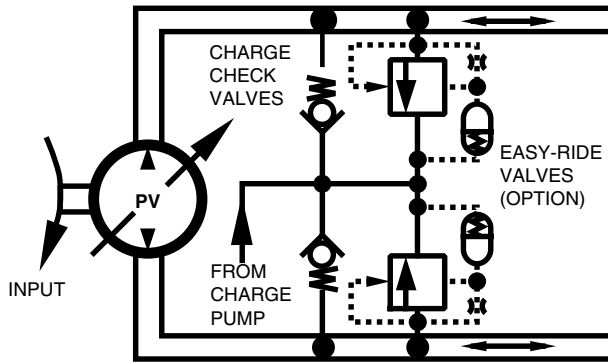

**Easy Ride Valve Circuit**

**Easy-Ride Valves**

The Series 70 BDU-21L transmissions are available with optional Easy-Ride valves to reduce the rate of change in acceleration (“jerkiness”) in vehicle propel applications. Each Easy-Ride valve incorporates a poppet-piston, sleeve assembly, valve spring, and plug.

A sudden increase in pressure in one side of the closed loop will open the corresponding Easy-Ride valve, allowing some high pressure fluid to flow to the opposite side of the loop through the charge circuit and charge check. This limits the pressure rise rate in the loop and reduces the acceleration rate of the vehicle.

The poppet-piston, sleeve assembly, and spring act as an accumulator. Once system pressure builds-up between the poppet-piston and sleeve assembly, the poppet-piston will move toward its seat, closing the passage.

A typical Easy-Ride valve cycle requires 0.5 to 1.0 seconds, depending on system oil viscosity and loop pressure. If the loop pressure is above the functional range of the valve (approximately 1500 psi [103 bar]), the valve spring will compress until the sleeve assembly contacts the plug, and the poppet-piston will be rapidly forced onto its seat.

## Notes

---

## General Technical Specifications

### Speed Ratings

**Maximum speed** is the highest operating speed recommended and cannot be exceeded without reduction in the life of the product or risking premature failure and loss of drive line power (which may create a safety hazard).

**Continuous speed** is the speed limit recommended at full power condition and is the highest value at which normal life can be expected.

### Pressure Limits

System pressure is a dominant operating variable affecting hydraulic unit life. High pressure, which results from high load, reduces expected life in a manner similar to many mechanical assemblies such as engines and gear boxes. There are load-life relationships for the rotating group and for the shaft anti-friction bearings.

**Maximum pressure** is the highest intermittent pressure allowed. It is determined by the maximum machine load demand. **Maximum pressure is assumed to occur a small percentage of operating time, usually less than 2% of the total.**

**Continuous pressure** is the average, regularly occurring pressure.

**Both the maximum and continuous pressure limits must be satisfied to achieve the expected life.**

### Series 70 / 15 Series Product Pressure Limits for 5 Year (@ 200 Hrs Usage / Yr.) Transmission Life Expectancy, psi (bar)

Product	Continuous Pressure	Maximum Pressure
Series 70-BD	1000 (69)	2100 (145)
15 Series	2500 (175)	4500 (310)

Operation at these pressure limits (under normal conditions) will give a five year life expectancy (@ 200 hours usage per year), assuming recommended maintenance procedures are followed. In the event that an extreme duty cycle is anticipated, consult Sauer-Sundstrand.

### Fluids

Ratings and data for Sauer-Sundstrand products are based on operating with premium hydraulic fluids containing oxidation, rust, and foam inhibitors.

These premium fluids include API CD engine oils per SAE J183, Type F automatic transmission fluids, power shift transmission fluids meeting Allison C-3 or Caterpillar TO-2 requirements and certain specialty agriculture tractor fluids. For further information, consult Sauer-Sundstrand.

At continuous operating conditions, fluid viscosity should be above 55 SUS (9 mm<sup>2</sup>/sec). Minimum fluid viscosity should be above 45 SUS (6.4 mm<sup>2</sup>/sec) at intermittent operating conditions.

### Filtration

A 20 micron (nominal rating) filter should be placed in the inlet line to the charge pump. The maximum continuous inlet vacuum should not exceed 10 in. Hg (0.7 bar abs.); the filter should be replaced when the inlet vacuum exceeds 10 in. Hg (0.7 bar abs.). During cold starts, the inlet vacuum may exceed this level. Inlet vacuum at normal operating conditions should not exceed 5 in. Hg (0.8 bar abs.).

### Reservoir Requirements

A suggested minimum reservoir volume is 5/8 of the total charge pump flow with a minimum fluid volume equal to 1/2 of the charge pump flow. This allows 30 seconds dwell time for removing any entrained air in the oil. This is adequate for a closed reservoir in most applications.

The reservoir outlet to the charge pump inlet should be near the bottom of the reservoir and must always be covered with fluid. The reservoir inlet (fluid return) from the transmission should be below the fluid level and be as far away as possible from the outlet port.

### Case Pressure

Under normal operating conditions, the maximum continuous case pressure must not exceed 4 psi (0.3 bar) for Series 70-BD units or 10 psi (0.7 bar) for 15 Series units. Maximum allowable intermittent case pressure during cold start must not exceed 10 psi (0.7 bar) for Series 70 units or 25 psi (1.7 bar) for 15 Series units.

**General Technical Specifications (Continued)**

**Temperature and Cooling**

The operating temperature of the transmission should not exceed 180° F (82° C) continuous and 220° F (104° C) intermittent. These temperature limits apply at the hottest point in the transmission, which is normally the case drain.

Heat exchangers may be installed in the case drain circuit if necessary, and should be sized to keep the fluid within recommended temperature limits. Testing to verify that these temperature limits are not exceeded is recommended.

Cold oil will generally not affect durability of the transmission components, but it may affect the ability to start the engine, flow oil, and transmit power. In general, cold starts may be made at a temperature 30° F (16° C) above the pour point of the fluid. The accompanying graph illustrates the relationship between shaft turning torque at 400 rpm and fluid viscosity.

**Cold Weather Torque to Turn  
(@ 400 RPM and 0 Swashplate Angle)**

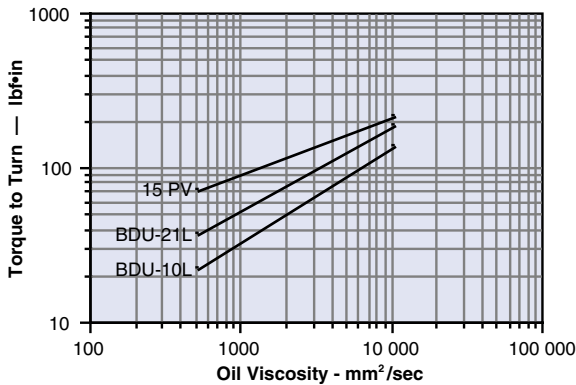

**Auxiliary Mounting Pad (15PV)**

The 15 Series pump is available with an optional SAE “A” mounting pad for mounting auxiliary hydraulic pumps. Since the auxiliary pad operates under case pressure, an O-ring must be used to seal the auxiliary pump mounting flange to the pad.

The 9 tooth spline has a 450 lb•in (51 Nm) continuous and 950 lb•in (107 Nm) maximum torque rating. These ratings assume a 58 Rc hardness on the mating pump shaft and 0.53 in. (13.5 mm) minimum spline engagement. The continuous torque rating is based on spline tooth wear.

**Mounting Flange Loads (15PT)**

Subjecting 15 Series tandem pumps to high shock loads may result in excessive loading of the mounting flange. Studs are provided at the rear of the unit for attaching a support bracket.

**Allowable Pump Input Shaft Side Loads**

The following graphs assume that a self tensioning device is used to supply tension to the belt, and that the belt tension is proportional to the amount of torque required to turn the shaft. Since torque is proportional to the system pressure generated, belt tension can be determined by knowing the operating system pressure and the pitch diameter of the sheave.

Typical self tension devices apply five times the tension to the tight side of the belt as is applied to the loose side of the belt. The following equations can be used to calculate the belt side load.

$$\text{Belt Side Load (lbs.)} = \frac{3 \times T_{in}}{D_s}$$

OR

$$\text{Belt Side Load (lbs.)} = \frac{K \times P}{D_s}$$

Where:

- T<sub>in</sub> = Maximum Shaft Input Torque in lb•in.
- D<sub>s</sub> = Sheave Pitch Diameter in inches
- P = System Working Pressure in psi
- K = Constant:  
 0.33 for BDP-10L or BDU-10L  
 0.68 for BDU-21L  
 0.48 for 15 Series

The accompanying graph represents the maximum allowable conditions based upon shaft stress. All external shaft loads will have an effect on bearing life. If continuously applied external loads exceed 25% of the maximum allowable, contact Sauer-Sundstrand for unit bearing life evaluation.

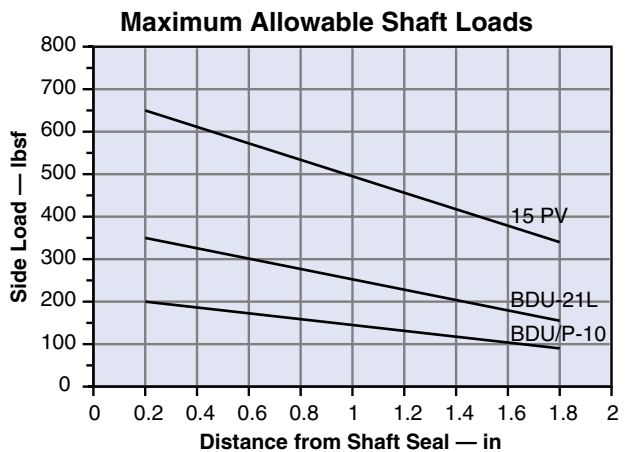



**General Technical Specifications (Continued)**

**Direct Displacement Control (DDC)**

The Direct Displacement Control can be located on either side of the Series 70 and 15 Series transmission or pump (except the BDP-10L). It provides a simple, positive method of control. Movement of the control shaft causes a proportional swashplate movement, thus varying the pump's displacement from full displacement in one direction to full displacement in the opposite direction.

Vehicle propel applications may require a provision for non-linear control input to reduce control sensitivity near neutral. Damping or frictional forces may be necessary to produce the desired control feel.

These units do not include any neutral centering device for the swashplate. It is necessary to provide a force in the machine's control system that will hold the swashplate at the desired angle. A "fail safe" design which will return the swashplate to neutral in the event of linkage failure is recommended.

**WARNING**

**With no external forces applied to the swashplate trunnion, internal hydraulic forces may not return the swashplate to the neutral position under all conditions of operation.**

The approximate torque necessary to rotate the control per 1000 psi (70 bar) of system operating pressure is as follows:

Series 70 BD-10	65 lbf•in per 1000 psi (7.3 Nm per 70 bar)
Series 70 BD-21	100 lbf•in per 1000 psi (11.3 Nm per 70 bar)
15 Series	65 lbf•in per 1000 psi (7.3 Nm per 70 bar)

The maximum torque that should be applied to the control under any condition is as follows:

Series 70 BD-10	200 lbf•in (22.6 Nm)
Series 70 BD-21	400 lbf•in (45.2 Nm)
15 Series	400 lbf•in (45.2 Nm)*

\* With a maximum radial force of 100 lbf (445 N) applied to the control shaft not more than 3 inches (76.2 mm) from the seal surface.

**Implement Pump Performance**

The following graphs provide typical implement pump performance information for the Series 70-BDU-21L and the 15 Series units.

**BDU-21L Implement Flow (@ 3200 RPM)**

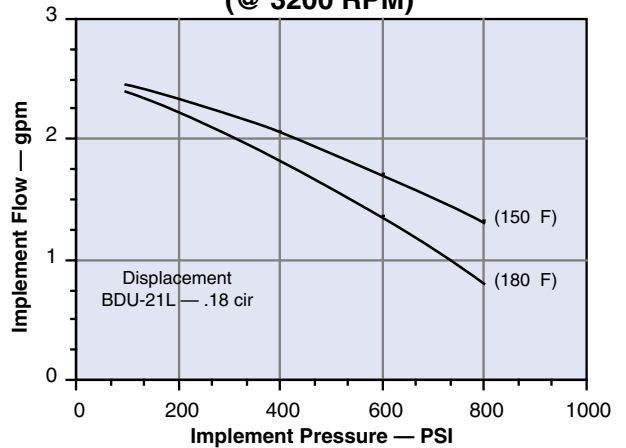

**15 Series Implement Flow (@ 3300 RPM and 180 F)**

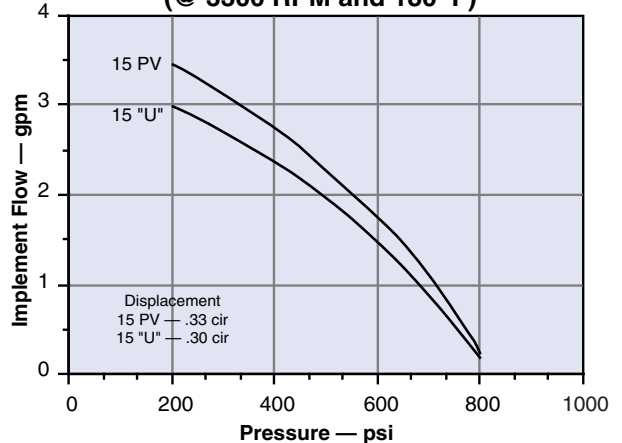

**BRAKING WARNING**

The loss of hydrostatic drive line power in any mode of operation may cause the loss of hydrostatic braking capacity. A braking system, redundant to the hydrostatic transmission must, therefore, be provided which is adequate to stop and hold the system should the condition develop.

Efficiency and Performance of Series 70 Units

The following graphs provide typical efficiency and performance information for Series 70 units.

**BDU-10L Overall Efficiency**  
(@ 3000 RPM Pump Input Speed)

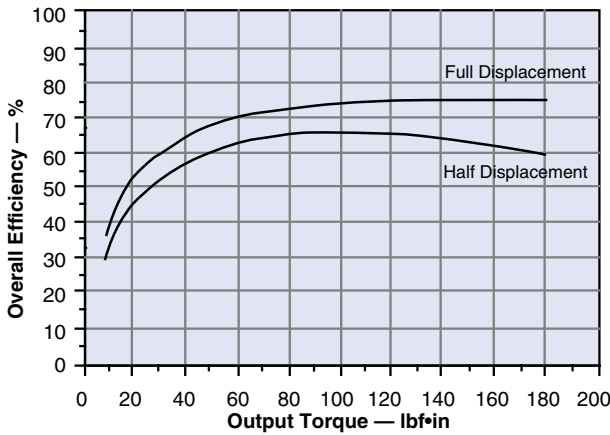

**BDU-10L Performance**  
(@ 3000 RPM Pump Input Speed)

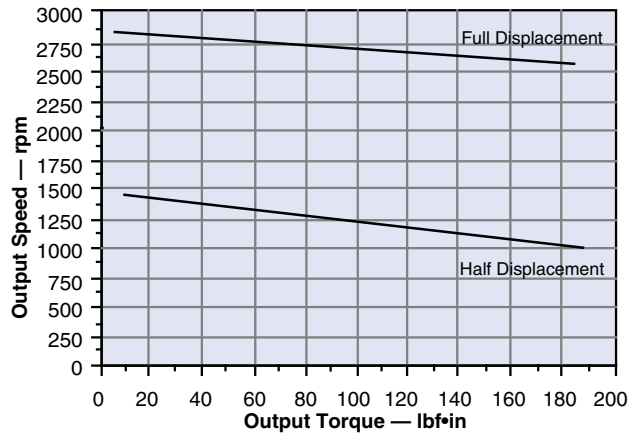

**BDP-10L Overall Efficiency**  
(@ Full Displacement [15 Swashplate Angle])

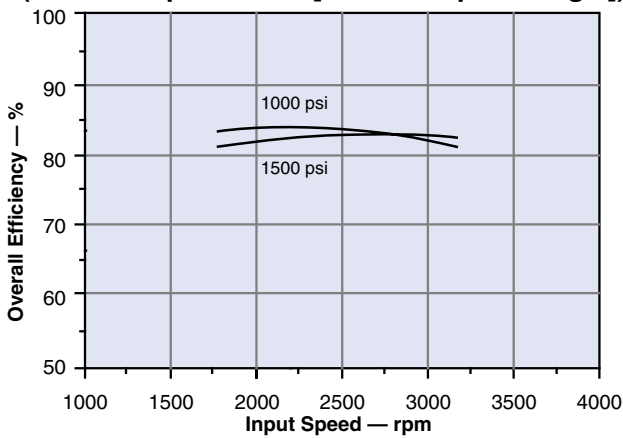

**BDP-10L OutputFlow**  
(@ Full Displacement [15 Swashplate Angle])

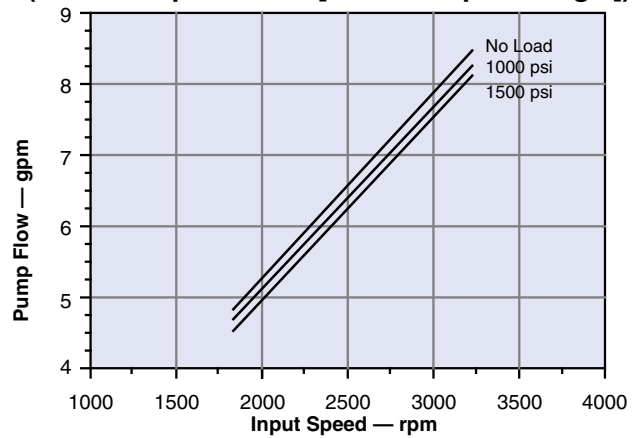

**BDU-21L Overall Efficiency**  
(@ 3000 RPM Pump Input Speed)

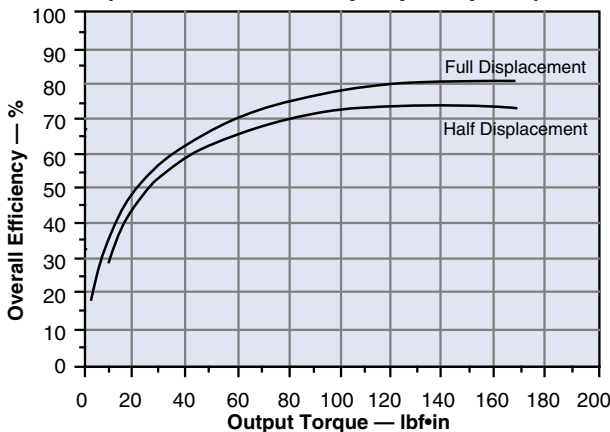

**BDU-21L Performance**  
(@ 3000 RPM Pump Input Speed)

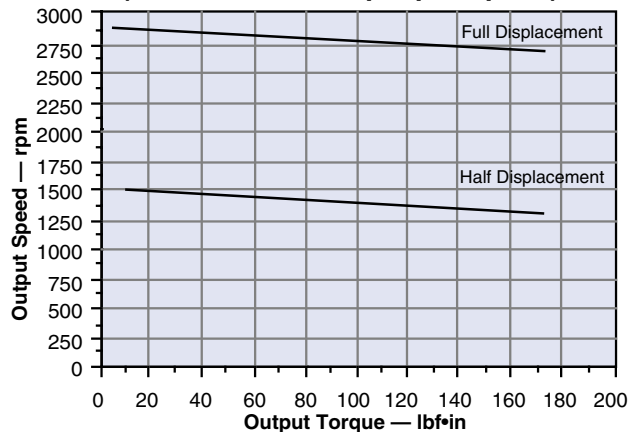

### Efficiency and Performance of 15 Series Units

The following graphs provide typical efficiency and performance information for 15 Series units.

**15 PV OutputFlow  
(@ Full Displacement)**

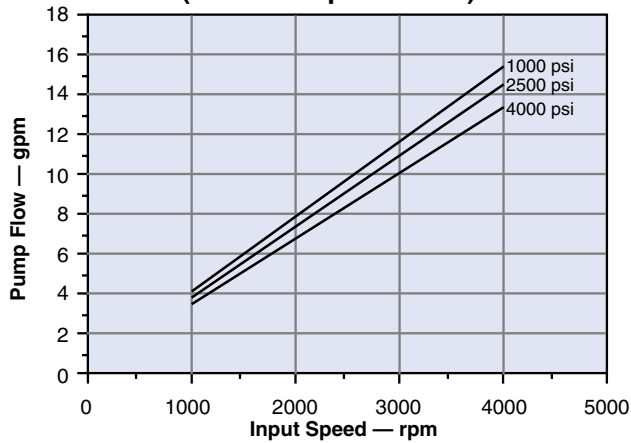

**15 MF Output Speed**

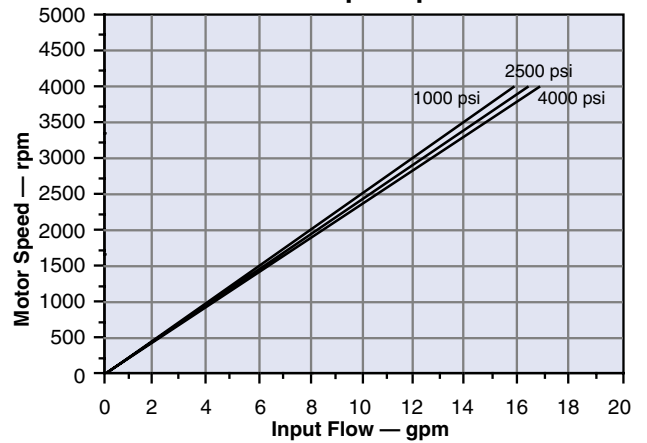

**15 "U" Overall Efficiency  
(@ 3300 RPM Pump Input Speed)**

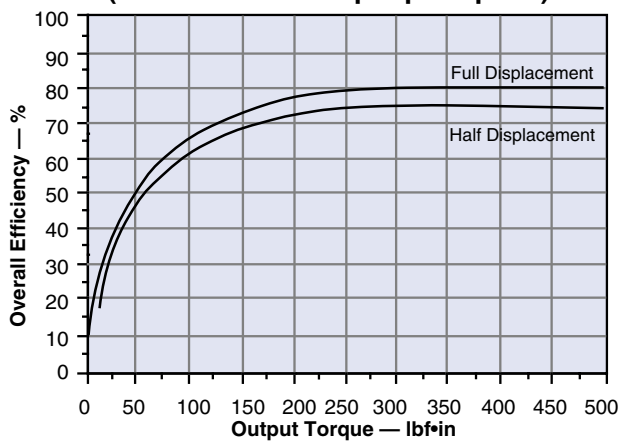

**15 "U" Performance  
(@ 3300 RPM Pump Input Speed)**

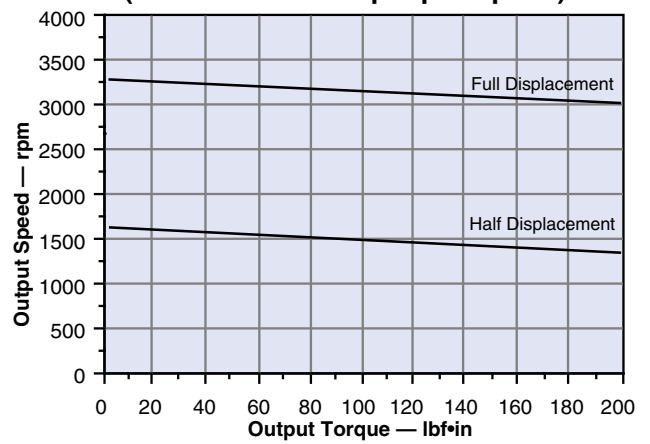

**Definitions of Typical Lawn and Garden and Turf Maintenance Vehicles**

Lawn Tractor – Vehicle with an 8 to 16 horsepower (6 to 12 kW) gasoline engine that is used primarily for mowing with limited drawbar capability and some active ground engaging attachments (i.e. rotary tillers, snowblowers). Tire diameters are typically 18 to 20 in. (457 to 508 mm) and vehicle weights are generally 500 lbs. (227 kg) or less.

Yard Tractor – Vehicle with a 12 to 18 horsepower (9 to 13.5 kW) gasoline or diesel engine that is used primarily for mowing with some drawbar capability and some active ground engaging attachments (i.e. rotary tillers, snowblowers, front blade). Tire diameters are typically 20 to 23 in. (508 to 584 mm) and vehicle weights range from 650 to 850 lbs. (295 to 386 kg).

Garden Tractor – Vehicle with a 14 to 20 horsepower (10.5 to 15 kW) gasoline or diesel engine that is used as a mowing or utility vehicle. Capability for using passive ground engaging implements such as mold-board plows and front end loaders distinguish these tractors from yard tractors. Tire diameters are typically 23 to 28 in. (584 to 711 mm) and vehicle weights range from 1000 to 1200 lbs. (454 to 544 kg).

Front Mount Mower – Vehicle used primarily for mowing, where the mowing attachment is located in front of the machine. Some have accessory attachments such as brooms, snowblowers, and blades. The vehicle is usually driven through a transmission/transaxle arrangement and the rear wheels are steered. Vehicle weights and tire diameters vary in relation to the size of the mower.

Rear Engine Rider – Vehicle used primarily for mowing, where the mower deck is located under the machine. The engine is located at the rear, often under the operator's seat. The vehicle is usually driven through a transaxle arrangement and the front wheels are steered. Tire diameters are typically 18 in. (457 mm) or less, and vehicle weights are generally 500 lbs. (227 kg) or less.

Dual Path Mower – Vehicle used primarily for mowing with some accessory attachment capability. Usually a dual path propelled vehicle in which steering is done by controlling the speed of each drive wheel independently. Vehicle weights and tire diameters vary in relation to the size of the mower.

**Component Selection for Lawn and Garden or Turf Maintenance Vehicles**

Selecting the proper transmission for a vehicle begins with determining the maximum vehicle speed desired and the maximum tractive effort required. The transmission selected must meet both requirements.

Many lawn and garden hydrostatic transmissions are used in conjunction with readily available transaxles. The maximum hydrostatic motor speed can be calculated by using the following equation. The input speed to the pump should be 10% greater than the maximum motor speed.

$$\text{Max. Motor Speed (rpm)} = \frac{S \times \text{FDR} \times 168}{\text{LR}}$$

Where:

- S = Maximum Vehicle Speed in mph
- FDR = Transaxle Final Drive Ratio
- LR = Tire Loaded Radius in inches

A useful parameter for determining tractive effort is “pull ratio”. Pull ratio is a dimensionless term that is the ratio of tractive effort to gross vehicle weight. It is generally constant for each class of vehicle. These values may be used when actual vehicle tractive efforts are not known.

**Typical Pull Ratios for Lawn and Garden Vehicles**

Vehicle Class	Maximum Pull Ratio	Typical Pull Ratio
Lawn Tractor	0.73	0.18
Yard Tractor	0.80	0.20
Garden Tractor	1.00*	0.23
Front Mount Mower	0.80**	0.23
Rear Engine Rider	0.50	0.16
Dual Path Mower	0.85 / 2	0.25 / 2

\* Assumes weight transfer to the driving wheels from an implement.

\*\* Based on wheel slip for a four-wheel-drive vehicle on dry asphalt. For mower service on turf, a ratio of 0.62 may be more appropriate.

**Component Selection (Continued)**

Because there are no system pressure relief valves in Series 70 units and many 15 Series transmissions, the maximum hydrostatic motor torque should occur at the vehicle wheel slip condition. Because of weight transfer from pushing or pulling implements, it may be difficult to determine the true weight on the drive wheels at wheel slip. Experience has shown that the values listed under "Maximum Pull Ratio" in the above table can be used to determine the maximum tractive effort. The maximum hydrostatic motor torque can be calculated using the following equation:

$$\text{Max. Motor Torque (lbf in)} = \frac{\text{Maximum PR} \times \text{GVW} \times \text{LR}}{\text{FDR} \times \text{FD eff}}$$

Where:

- PR = Pull Ratio
- GVW = Gross Vehicle Weight in lbs.
- LR = Tire Loaded Radius in inches
- FDR = Transaxle Final Drive Ratio
- FD eff = Transaxle Final Drive Efficiency

Vehicles generally operate at the maximum tractive effort condition less than 2% of their life, therefore it is necessary to select a transmission which will give adequate life under typical operating conditions. If a duty cycle for the transmission is known, Sauer-Sundstrand can assist in calculating a weighted average or root cubic mean motor torque and can estimate the life expectancy of the transmission selected.

If the vehicle duty cycle is not known, then the values in the accompanying table listed under typical operating conditions can be used in the following equation for the motor torque determination. If the life is not adequate, the transaxle final drive ratio or tire size may need to be changed, or the next larger transmission may be needed. Contact Sauer-Sundstrand for assistance in the correct transmission selection.

$$\text{Typical Operating Motor Torque (lbf in)} = \frac{\text{Typ. PR} \times \text{GVW} \times \text{LR}}{\text{FDR} \times \text{FD eff}}$$

Where:

- Typ. PR = Typical Pull Ratio
- GVW = Gross Vehicle Weight in lbs.
- LR = Tire Loaded Radius in inches
- FDR = Transaxle Final Drive Ratio
- FD eff = Transaxle Final Drive Efficiency

**Series 70 / 15 Series Transmission System Operating Pressure Limits (and Corresponding Motor Output Torques) for 5 Year Life Expectancy**

Pressure in psi (Torque in lbf•in)

Typical Continuous Operating Limits			
Usage Hrs./Yr.	Product		
	BDU-10L	BDU-21L	15 Series
100	1300 (115)	1300 (250)	3000 (410)
200	1000 (85)	1000 (190)	2600 (350)
300	800 (70)	800 (155)	2000 (270)
400	650 (55)	650 (125)	1500 (195)

Maximum Operating Limits			
Usage Hrs./Yr.	Product		
	BDU-10L	BDU-21L	15 Series
100	2100 (180)	2100 (400)	4500 (610)
200	2100 (180)	2100 (400)	4500 (610)
300	1900 (170)	1900 (380)	4000 (525)
400	1800 (160)	1800 (355)	3600 (480)

NOTE: Operation at these pressure and output torque limits (under normal conditions) will give a five year life expectancy, assuming recommended maintenance procedures are followed. In the event that an extreme duty cycle is anticipated, consult Sauer-Sundstrand.

Dimensions • Series 70 BDU-10S and BDU-10L Transmission

inches  
[mm]

Input Shaft Rotation	CW		CCW	
Control Shaft Rotation	A	B	A	B
Output Shaft Rotation	CW	CCW	CCW	CW

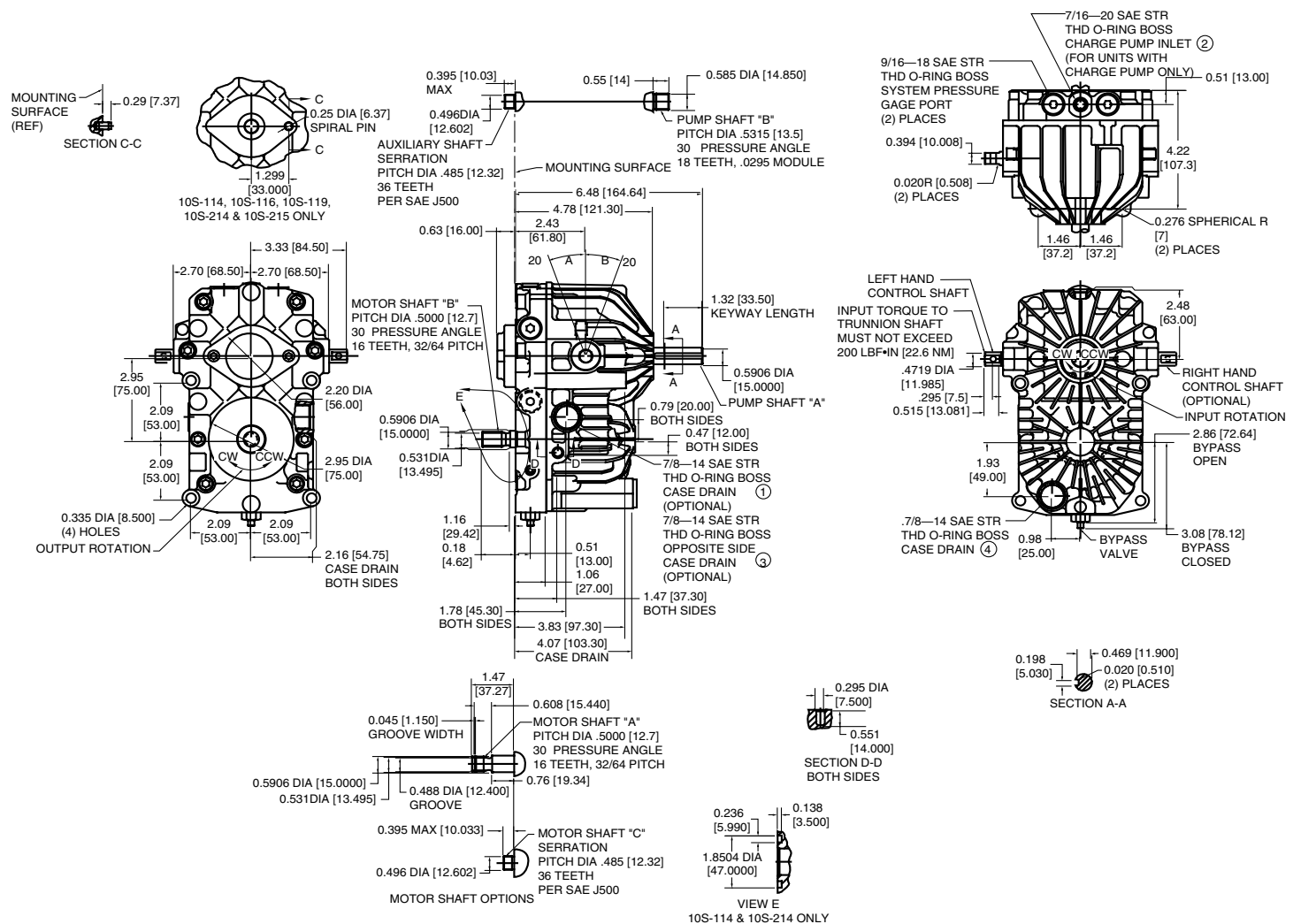

**Dimensions • Series 70 BDP-10L Pump**

inches  
[mm]

Input Shaft Rotation	CW		CCW	
Control Shaft Rotation	A	B	A	B
Port A Flow	Out	In	In	Out
Port B Flow	In	Out	Out	In

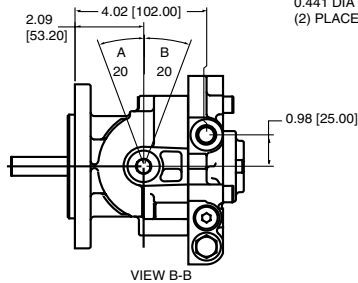
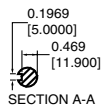
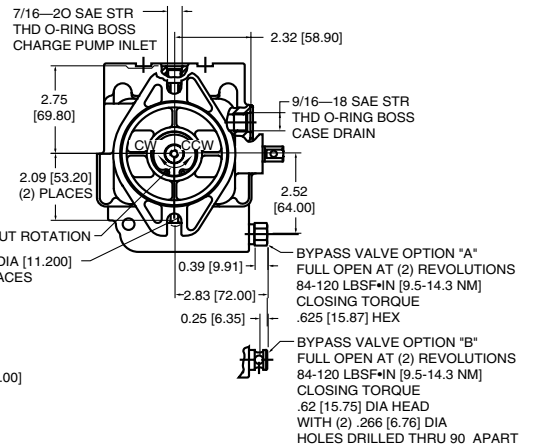
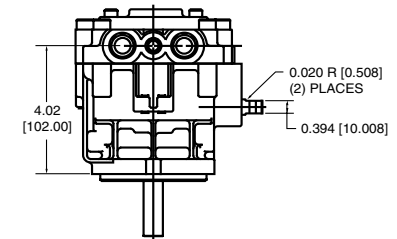
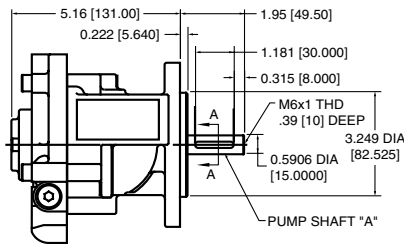
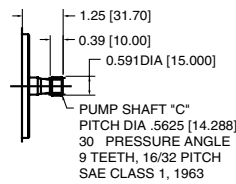
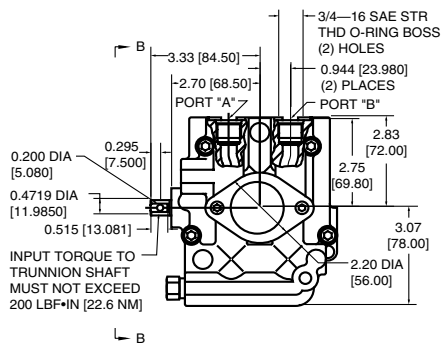

Dimensions • Series 70 BDU-21L Transmission

inches  
[mm]

Input Shaft Rotation	CW		CCW	
Control Shaft Rotation	A	B	A	B
Output Shaft Rotation	CCW	CW	CW	CCW

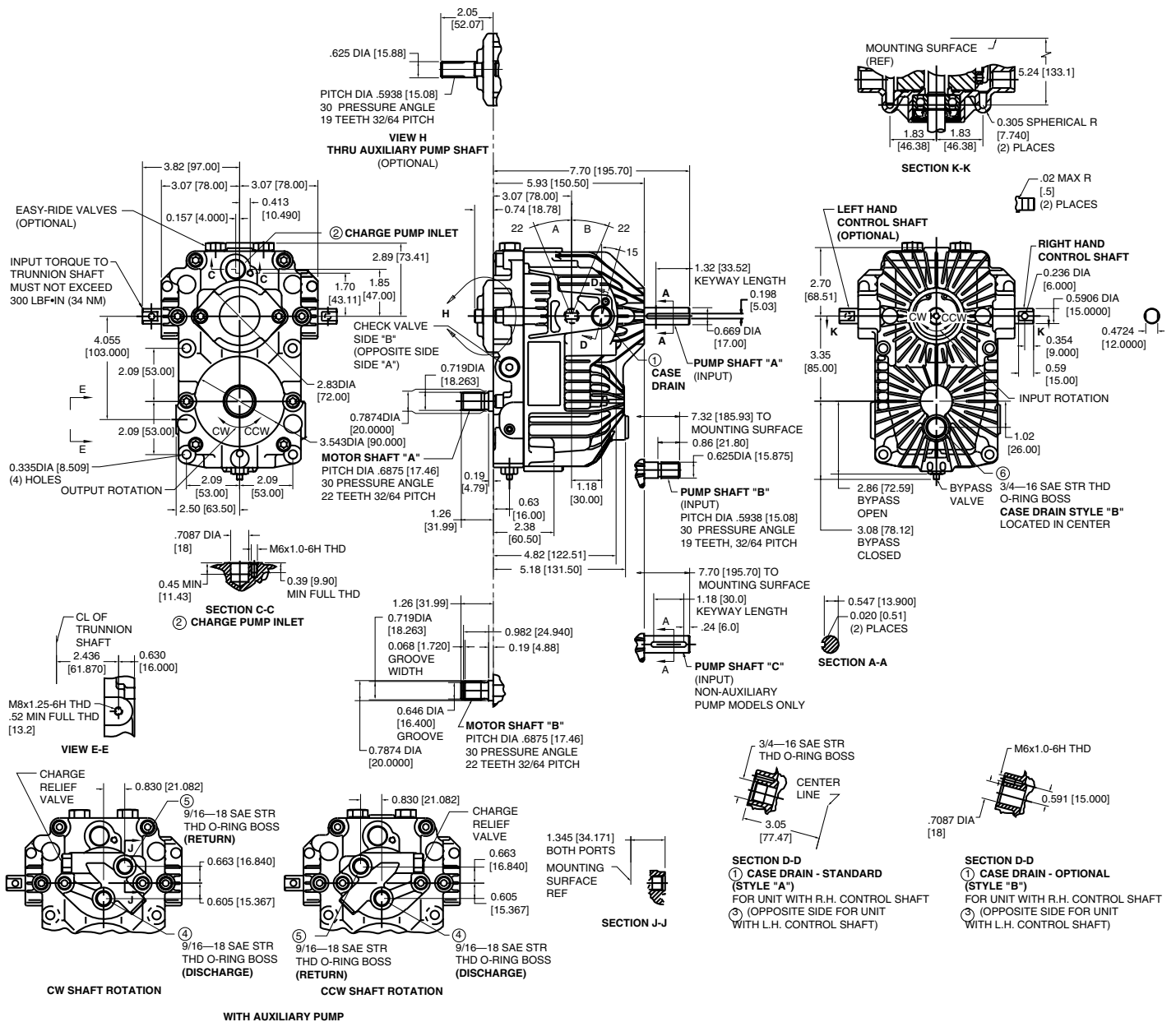



Dimensions • 15 Series Variable Displacement Pump • 15 PV

mm  
[in.]

Input Shaft Rotation	CW		CCW	
Control Trunnion Rotation	a	b	a	b
Port A Flow	In	Out	Out	In
Port B Flow	Out	In	In	Out

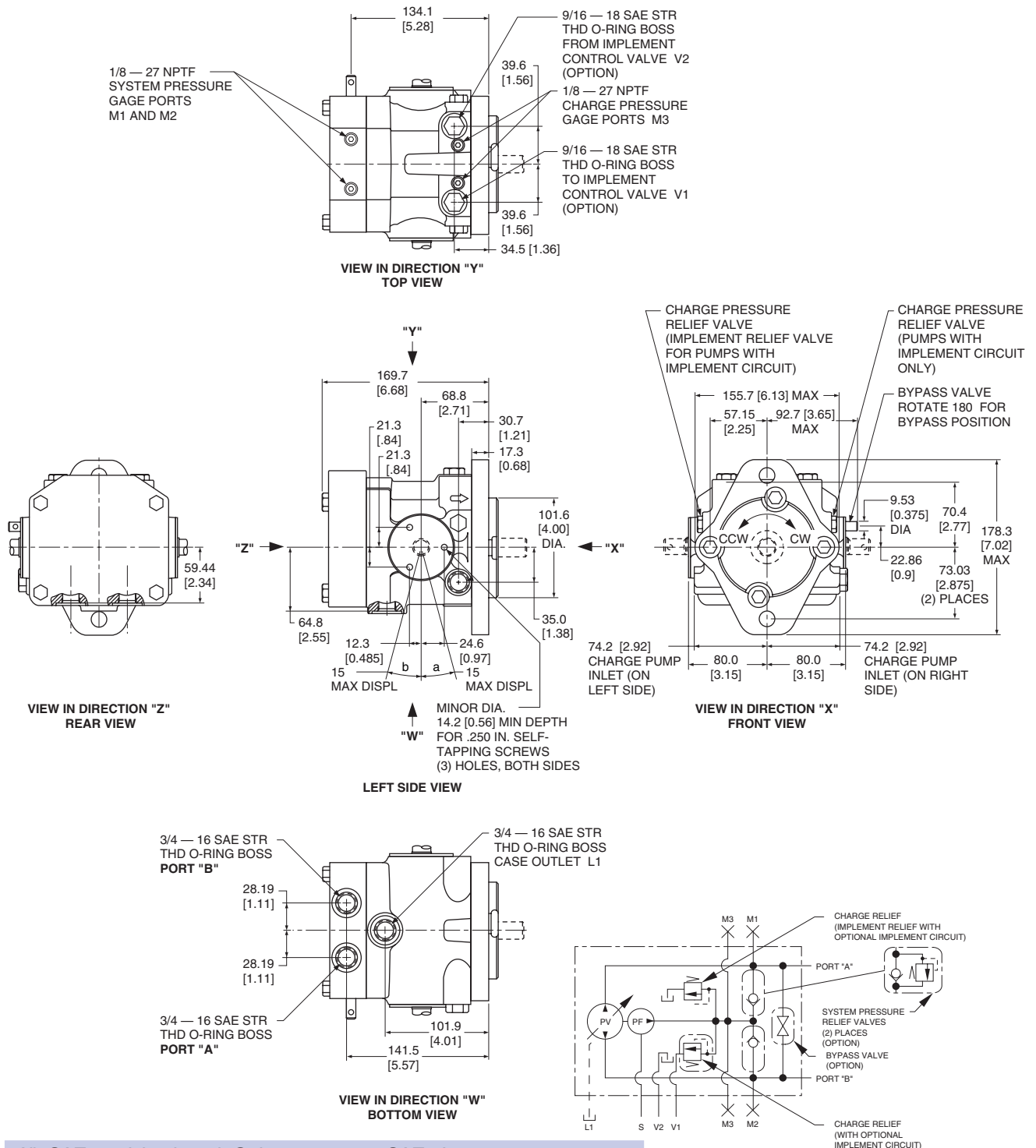

All SAE straight thread O-ring ports per SAE J514.

Shaft rotation is determined by viewing pump from input shaft end.

Contact SAUER-SUNDSTRAND Application Engineering for specific installation drawings.

**Dimensions • 15 Series Variable Displacement Pump • 15 PV (Continued)**

mm  
[in.]

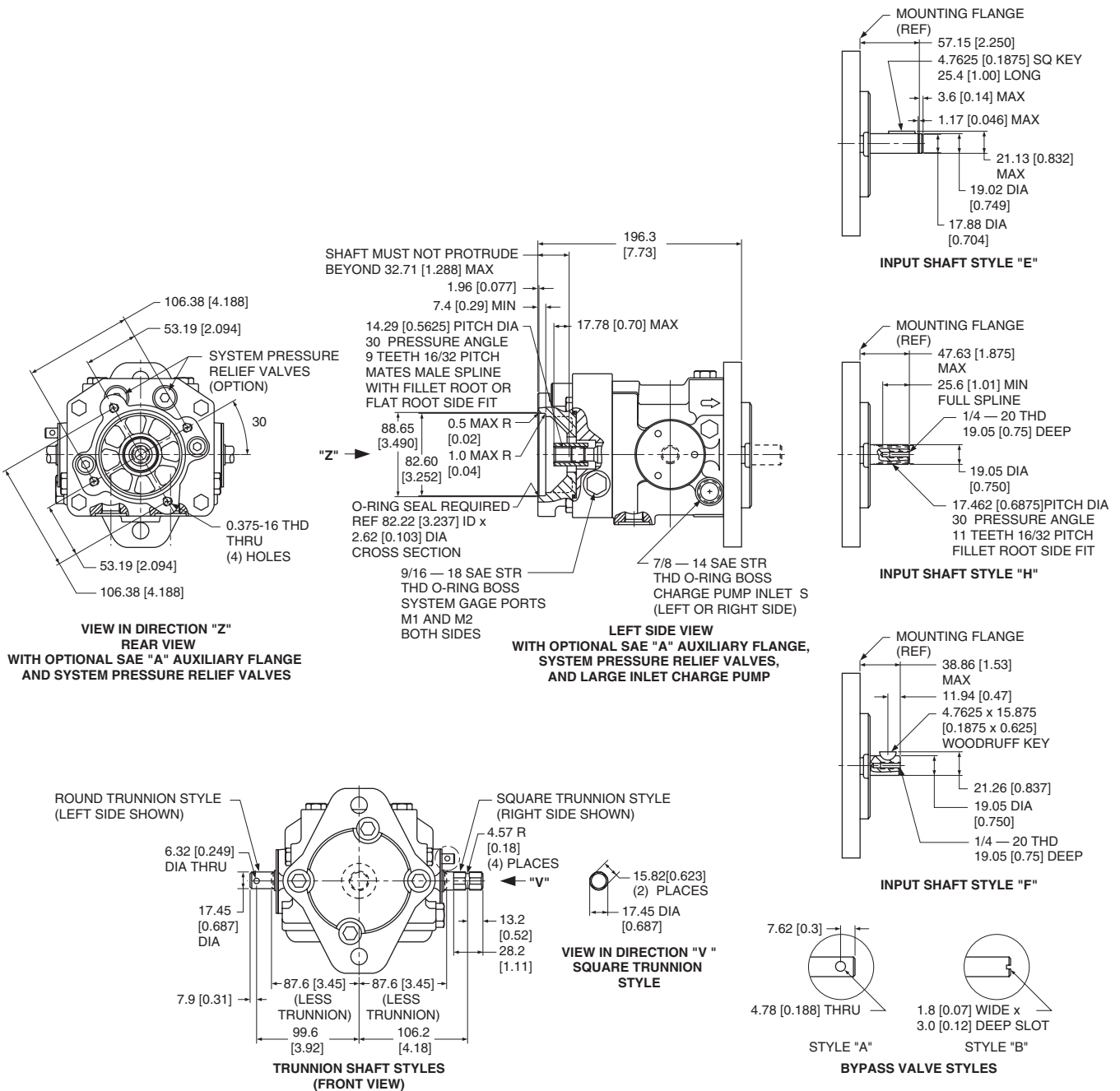

All SAE straight thread O-ring ports per SAE J514.

Shaft rotation is determined by viewing pump from input shaft end.

Contact SAUER-SUNDSTRAND Application Engineering for specific installation drawings.



Dimensions • 15 Series Fixed Displacement Motor • 15 MF

Dimensions in inches

Output Shaft Rotation	Flow Direction	
	Port A	Port B
Clockwise (CW)	In	Out
Counter-clockwise (CCW)	Out	In

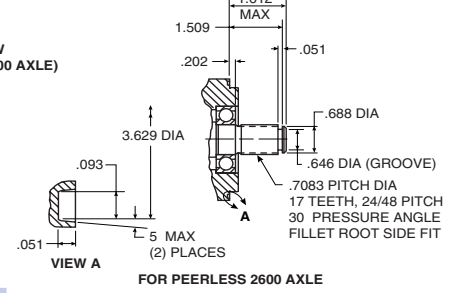
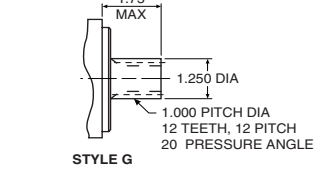
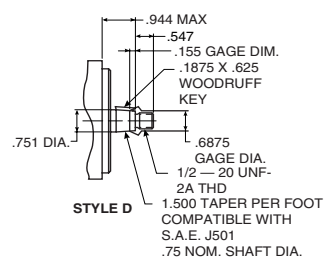
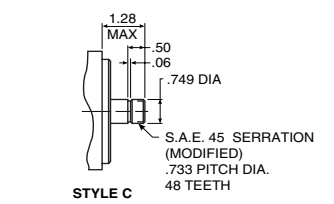
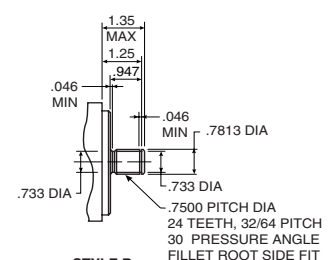
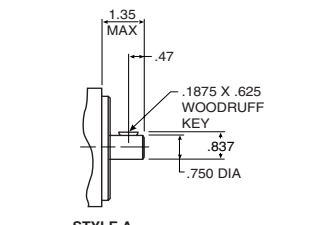
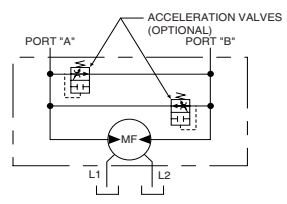
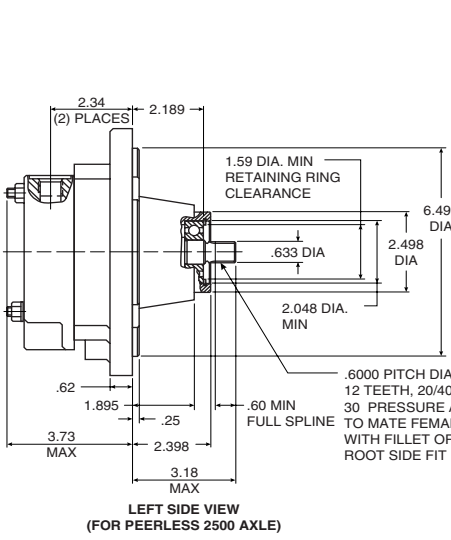
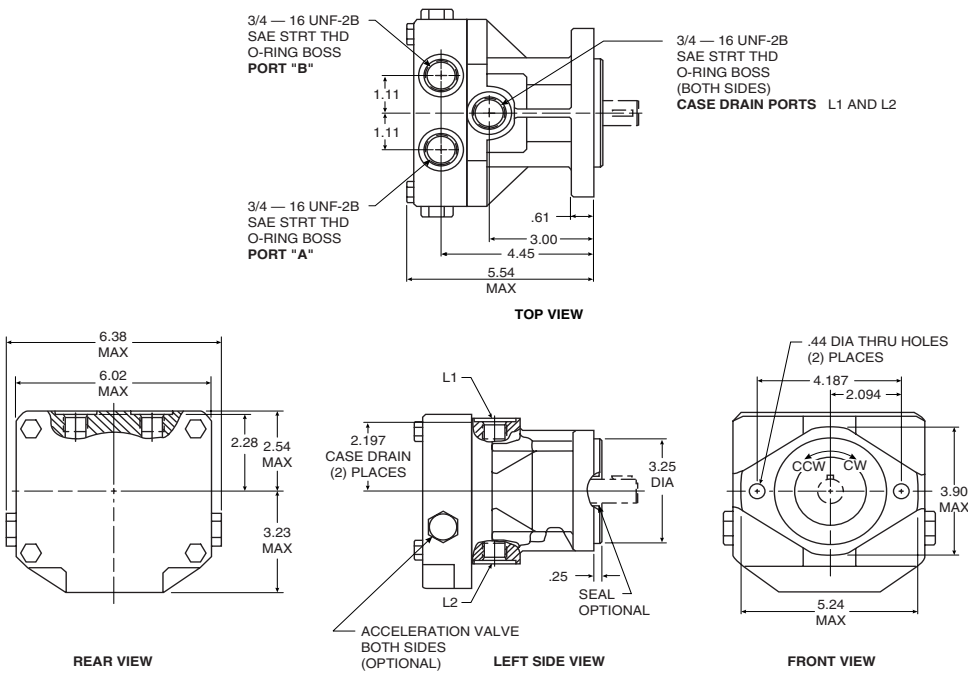

All SAE straight thread O-ring ports per SAE J514.  
 Shaft rotation is determined by viewing motor from output shaft end.  
 Contact SAUER-SUNDSTRAND Application Engineering for specific installation drawings.

Dimensions • 15 Series In-line Transmission

Dimensions in inches

Input Shaft Rotation	CW		CCW	
Control Trunnion Rotation	a	b	a	b
Output Shaft Rotation	CCW	CW	CW	CCW

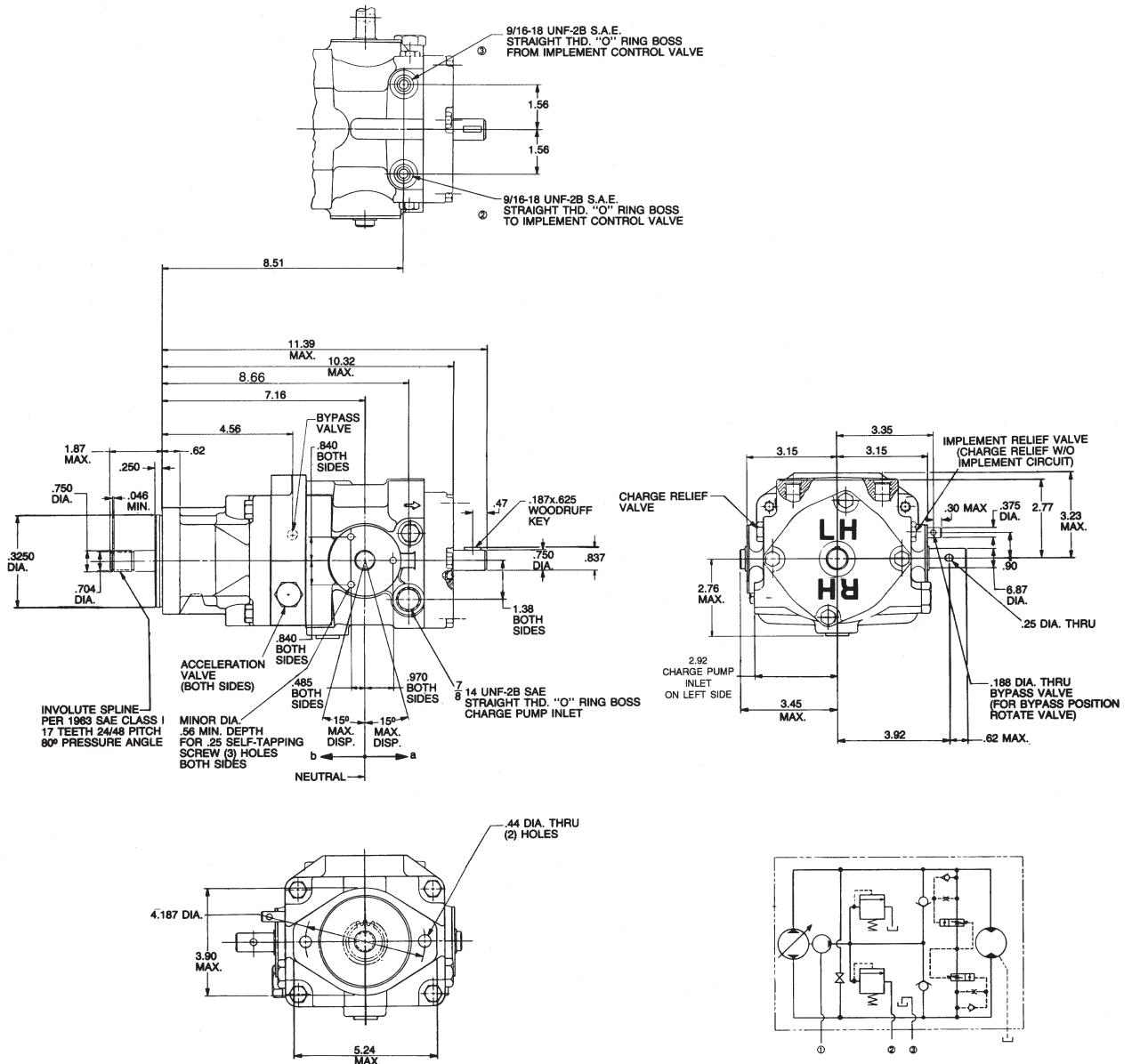

Dimensions • 15 Series “U” Style Transmission (15U)

Dimensions in inches

Input Shaft Rotation	CW		CCW	
Control Trunnion Rotation	a	b	a	b
Output Shaft Rotation	CW	CCW	CCW	CW

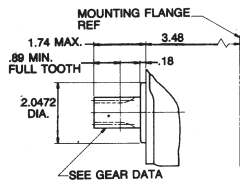
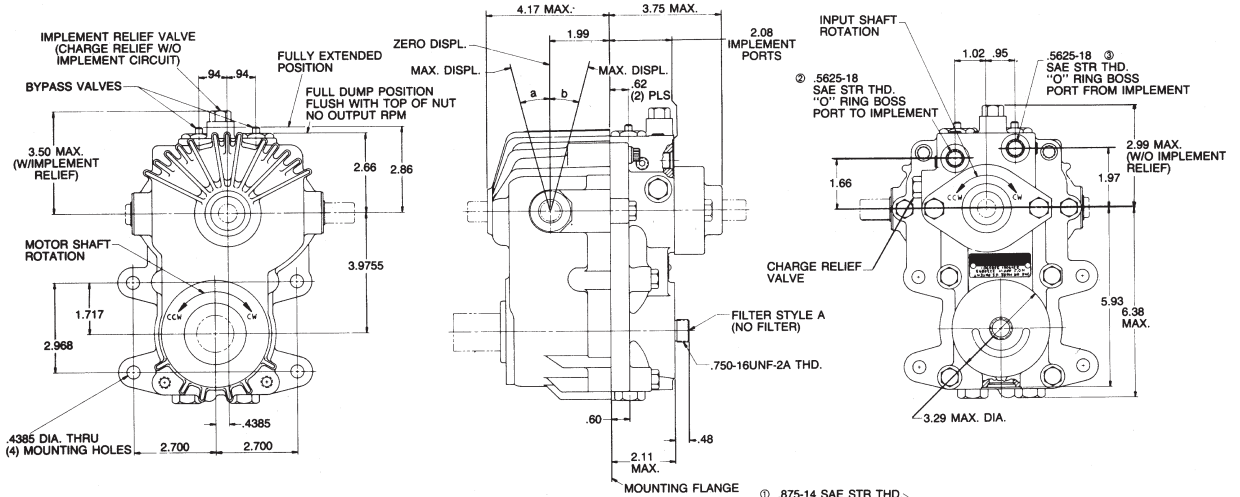

Shaft Style	Shaft Dia.	Pitch Dia.	No. Teeth	Pitch	Press. Angle
A	1.05	.833	10	12	25°
B	1.25	1.00	12	12	20°

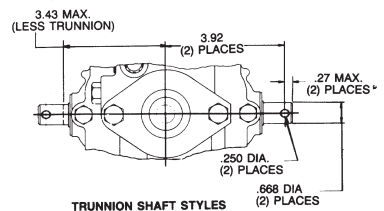
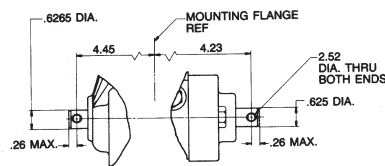

PUMP SHAFT STYLE A

TRUNNION SHAFT STYLES

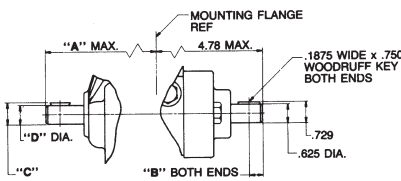
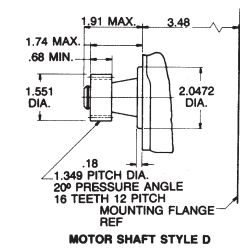

Shaft Style	Dim. "A"	Dim. "B"	Dim. "C"	Dim. "D"
C	5.04	.45	.731	.626
D	5.35	.47	.875	.750
E	5.35	.47	.729	.625

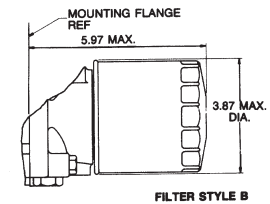

FILTER STYLE B

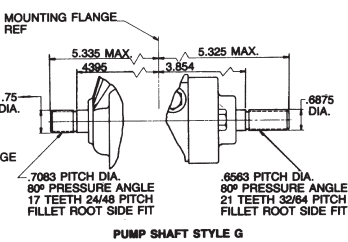
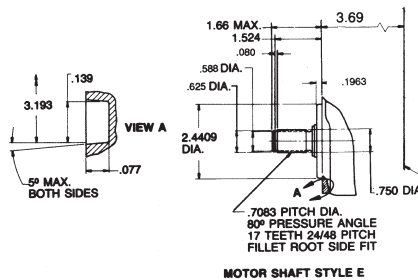

PUMP SHAFT STYLE G

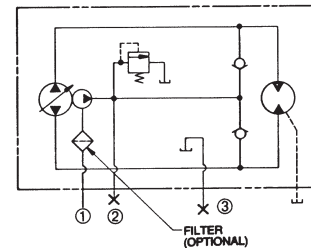







## Hydraulic Power Systems

### SAUER-SUNDSTRAND Hydraulic Power Systems - Market Leaders Worldwide

SAUER-SUNDSTRAND is a world leader in the design and manufacture of Hydraulic Power Systems. Research and development resources in both North America and Europe enable SAUER-SUNDSTRAND to offer a wide range of design solutions utilizing hydraulic power system technology.

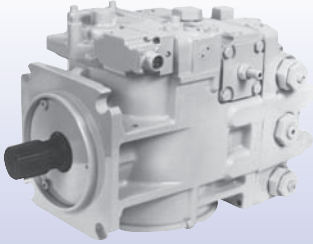
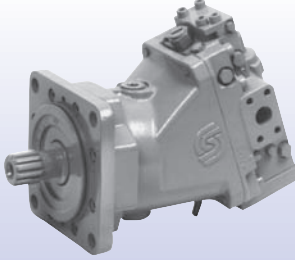
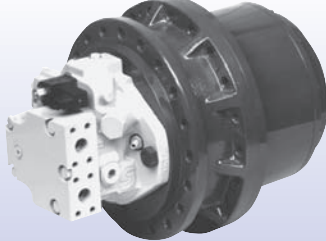
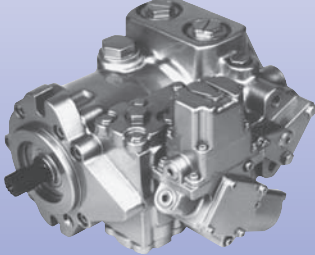
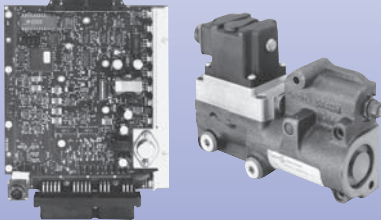
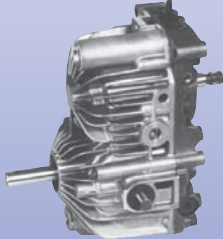
SAUER-SUNDSTRAND specializes in integrating a full range of system components to provide vehicle designers with the most advanced total-design system.

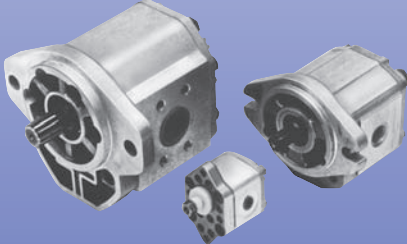
SAUER-SUNDSTRAND is Your World Source for Controlled Hydraulic Power Systems.

 <p>Heavy Duty Axial Piston Pumps and Motors</p>	 <p>Heavy Duty Bent Axis Variable Motors</p>	 <p>Cartridge Motors/ Compact Wheel Drives</p>
 <p>Medium Duty Axial Piston Pumps and Motors</p>	 <p>Mikrocontrollers Electrohydraulic and Controls</p>	 <p>Hydrostatic Transmissions Packages</p>
 <p>Open Circuit Axial Piston Pumps</p>	 <p>Gear Pumps and Motors</p>	 <p>Genuine Service Parts</p>

### Worldwide Service Support

SAUER-SUNDSTRAND provides comprehensive worldwide service for its products through an extensive network of Authorized Service Centers strategically located in all parts of the world.

Look to SAUER-SUNDSTRAND for the best in WORLDWIDE SERVICE.

