

ENGINEERING
TOMORROW



Technical Information

Hydraulic Brakes

BK, AB, FB, SB, RP Series



Revision history

Table of revisions

Date	Changed	Rev
June 2019	Spelling and grammatical updates	0103
Nov 2017	Updated SB 930 max. release pressure rating	0102
Mar 2017	First edition	0101

Contents

Technical Information

Operating Recommendations..... 4
 Oil Type..... 4
 Fluid Viscosity and Filtration..... 4
 Installation and Start-up..... 4
 Hydraulic Motor Safety Precaution..... 4
 Hydraulic Brake Precaution..... 4
 Allowable Bearing and Shaft Loading..... 5
 Vehicle Drive Calculations..... 6
 Induced Side Load..... 9
 Hydraulic Equations..... 10
 Shaft Nut Information..... 11

BK 913 and 915 Series

BK 913 and 915 Series Housings..... 14
 BK 913 and 915 Series Technical Information..... 14
 BK 913 and 915 Series Shafts..... 16
 BK 913 and 915 Series Ordering Information..... 16

AB 920 Series

AB 920 Series Housings..... 17
 AB 920 Series Technical Information..... 18
 AB 920 Series Shafts..... 19
 AB 920 Series Ordering Information..... 19

FB 925 Series

FB 925 Series Housings..... 20
 FB 925 Series Technical Information..... 21
 FB 925 Series Shafts..... 22
 FB 925 Series Ordering Information..... 22

SB 930 Series

SB 930 Series Housings..... 24
 SB 930 Series Shafts..... 25
 SB 930 Series Technical Information..... 26
 SB 930 Series Installation Information..... 26
 SB 930 Series Ordering Information..... 27

RP 960 Series

RP 960 Series Ordering Information..... 29

Technical Information

Operating Recommendations

Oil Type

Hydraulic oils with anti-wear, anti-foam and demulsifiers are recommended for systems incorporating Danfoss motors. Straight oils can be used but may require VI (viscosity index) improvers depending on the operating temperature range of the system. Other water based and environmentally friendly oils may be used, but service life of the motor and other components in the system may be significantly shortened. Before using any type of fluid, consult the fluid requirements for all components in the system for compatibility. Testing under actual operating conditions is the only way to determine if acceptable service life will be achieved.

Fluid Viscosity and Filtration

Fluids with a viscosity between 20 - 43 cSt [100 - 200 S.U.S.] at operating temperature is recommended. Fluid temperature should also be maintained below 85°C [180° F]. It is also suggested that the type of pump and its operating specifications be taken into account when choosing a fluid for the system. Fluids with high viscosity can cause cavitation at the inlet side of the pump. Systems that operate over a wide range of temperatures may require viscosity improvers to provide acceptable fluid performance.

Danfoss recommends maintaining an oil cleanliness level of ISO 17-14 or better.

Installation and Start-up

When installing a Danfoss motor it is important that the mounting flange of the motor makes full contact with the mounting surface of the application. Mounting hardware of the appropriate grade and size must be used. Hubs, pulleys, sprockets and couplings must be properly aligned to avoid inducing excessive thrust or radial loads. Although the output device must fit the shaft snug, a hammer should never be used to install any type of output device onto the shaft. The port plugs should only be removed from the motor when the system connections are ready to be made. To avoid contamination, remove all matter from around the ports of the motor and the threads of the fittings. Once all system connections are made, it is recommended that the motor be run-in for 15-30 minutes at no load and half speed to remove air from the hydraulic system.

Hydraulic Motor Safety Precaution

A hydraulic motor must not be used to hold a suspended load. Due to the necessary internal tolerances, all hydraulic motors will experience some degree of creep when a load induced torque is applied to a motor at rest. All applications that require a load to be held must use some form of mechanical brake designed for that purpose.

Hydraulic Brake Precaution

Caution

Danfoss' brakes are intended to operate as static or parking brakes. System circuitry must be designed to bring the load to a stop before applying the brake.

To achieve proper brake release operation, it is necessary to bleed out any trapped air and fill brake release cavity and hoses before all connections are tightened. To facilitate this operation, all motor/brakes feature two release ports. One or both of these ports may be used to release the brake in the unit. Motor/brakes should be configured so that the release ports are near the top of the unit in the installed position.

Once all system connections are made, one release port must be opened to atmosphere and the brake release line carefully charged with fluid until all air is removed from the line and motor/brake release cavity. When this has been accomplished the port plug or secondary release line must be reinstalled. In the event of a pump or battery failure, an external pressure source may be connected to the brake release port to release the brake, allowing the machine to be moved.

Technical Information

Allowable Bearing and Shaft Loading

This catalog provides curves showing allowable radial loads at points along the longitudinal axis of the motor. They are dimensioned from the mounting flange. Two capacity curves for the shaft and bearings are shown. A vertical line through the centerline of the load drawn to intersect the x-axis intersects the curves at the load capacity of the shaft and of the bearing.

In the example below, the maximum radial load bearing rating is between the internal roller bearings illustrated with a solid line. The allowable shaft rating is shown with a dotted line.

The bearing curves for each model are based on laboratory analysis and testing conducted at Danfoss. The shaft loading is based on a 3:1 safety factor and 330 Kpsi tensile strength. The allowable load is the lower of the curves at a given point. For instance, one inch in front of the mounting flange the bearing capacity is lower than the shaft capacity. In this case, the bearing is the limiting load. The motor user needs to determine which series of motor to use based on their application knowledge.

ISO 281 Ratings vs. Manufacturer's Ratings

Published bearing curves can come from more than one type of analysis. The ISO 281 bearing rating is an international standard for the dynamic load rating of roller bearings. The rating is for a set load at a speed of 33 1/3 RPM for 500 hours (1 million revolutions). The standard was established to allow consistent comparisons of similar bearings between manufacturers. The ISO 281 bearing ratings are based solely on the physical characteristics of the bearings, removing any manufacturers specific safety factors or empirical data that influences the ratings.

Manufacturers' ratings are adjusted by diverse and systematic laboratory investigations, checked constantly with feedback from practical experience. Factors taken into account that affect bearing life are material, lubrication, cleanliness of the lubrication, speed, temperature, magnitude of the load and the bearing type.

The operating life of a bearing is the actual life achieved by the bearing and can be significantly different from the calculated life. Comparison with similar applications is the most accurate method for bearing life estimations.

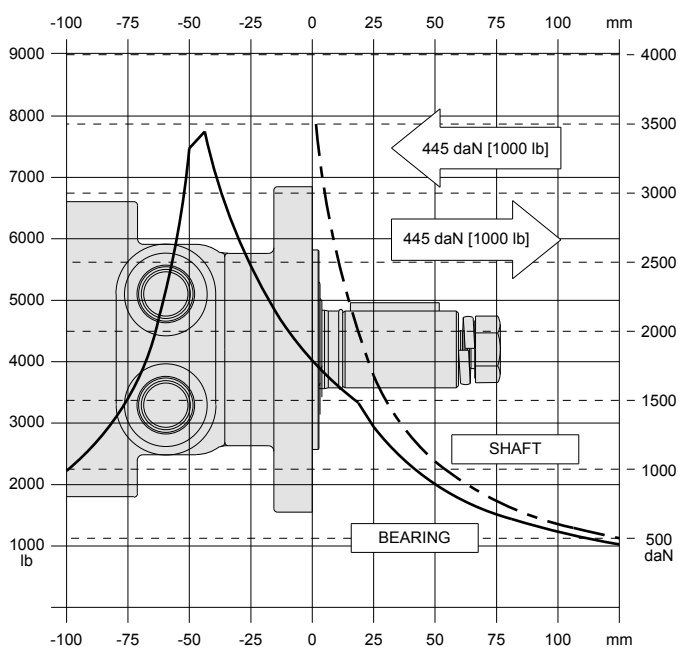

P109320

Technical Information

Example Load Rating for Mechanically Retained Needle Roller Bearings

Bearing Life L_{10}	(C/P) ^p [10 ⁶ revolutions]
L_{10}	nominal rating life
C	dynamic load rating
P	equivalent dynamic load
Life Exponent p	10/3 for needle bearings

Bearing Load Multiplication Factor Table

RPM	Factor
50	1.23
100	1.00
200	0.81
300	0.72
400	0.66
500	0.62
600	0.58
700	0.56
800	0.50

Vehicle Drive Calculations

When selecting a wheel drive motor for a mobile vehicle, a number of factors concerning the vehicle must be taken into consideration to determine the required maximum motor RPM, the maximum torque required and the maximum load each motor must support. The following sections contain the necessary equations to determine this criteria. An example is provided to illustrate the process.

Sample application (vehicle design criteria)

vehicle description	4 wheel vehicle
vehicle drive	2 wheel drive
GVW	1,500 lbs.
weight over each drive wheel	425 lbs.
rolling radius of tires	16 in.
desired acceleration	0-5 mph in 10 sec.
top speed	5 mph
gradability	20%
worst working surface	poor asphalt

To determine maximum motor speed

$$RPM = (2.65 \times KPH \times G) / r_m \text{ or } RPM = (168 \times MPH \times G) / r_i$$

KPH max. vehicle speed (kilometers/hr)

MPH max. vehicle speed (miles/hr)

Technical Information

- G** gear reduction ratio (if none, G = 1)
- rm** rolling radius of tire (meters)
- ri** rolling radius of tire (inches)

$$\text{RPM} = (168 \times 5 \times 1) / 16 = 52.5$$

To determine maximum torque requirement of motor

To choose a motor(s) capable of producing enough torque to propel the vehicle, it is necessary to determine the Total Tractive Effort (TE) requirement for the vehicle. To determine the total tractive effort, the following equation must be used:

$$\text{TE} = \text{RR} + \text{GR} + \text{FA} + \text{DP} \text{ (lbs or N)}$$

- TE** Total tractive effort
- RR** Force necessary to overcome rolling resistance
- GR** Force required to climb a grade
- FA** Force required to accelerate
- DP** Drawbar pull required

The components for this equation may be determined using the following steps.

Step One: Determine Rolling Resistance

Rolling Resistance (RR) is the force necessary to propel a vehicle over a particular surface. It is recommended that the worst possible surface type to be encountered by the vehicle be factored into the equation.

$$\text{RR} = (\text{GVW} / 1000) \times \text{R} \text{ (lb or N)}$$

- GVW** gross (loaded) vehicle weight (lb or kg)
- R** surface friction (value from [Rolling Resistance](#) on page 7)

Rolling Resistance

Concrete (excellent)	10
Concrete (good)	15
Concrete (poor)	20
Asphalt (good)	12
Asphalt (fair)	17
Asphalt (poor)	22
Macadam (good)	15
Macadam (fair)	22
Macadam (poor)	37
Cobbles (ordinary)	55
Cobbles (poor)	37
Snow (2 inch)	25
Snow (4 inch)	37
Dirt (smooth)	25
Dirt (sandy)	37
Mud	37 to 150

Technical Information

Rolling Resistance (continued)

Sand (soft)	60 to 150
Sand (dune)	160 to 300

Step Two: Determine Grade Resistance

Grade Resistance (GR) is the amount of force necessary to move a vehicle up a hill or “grade.” This calculation must be made using the maximum grade the vehicle will be expected to climb in normal operation.

To convert incline degrees to % Grade:

$$\% \text{ Grade} = [\tan \text{ of angle (degrees)}] \times 100$$

$$\text{GR} = (\% \text{ Grade} / 100) \times \text{GVW (lb or N)}$$

Example: $\text{GR} = (20 / 100) \times 1500 \text{ lbs} = 300 \text{ lbs}$

Step Three: Determine Acceleration Force

Acceleration Force (FA) is the force necessary to accelerate from a stop to maximum speed in a desired time.

$$\text{FA} = (\text{KPH} \times \text{GVW (N)}) / (35.32 \times t) \text{ or } \text{FA} = (\text{MPH} \times \text{GVW (lb)}) / (22 \times t)$$

t time to maximum speed (seconds)

Example: $\text{FA} = (5 \times 1500 \text{ lbs}) / (22 \times 10) = 34 \text{ lbs}$

Step Four: Determine Drawbar Pull

Drawbar Pull (DP) is the additional force, if any, the vehicle will be required to generate if it is to be used to tow other equipment. If additional towing capacity is required for the equipment, repeat steps one through three for the towable equipment and sum the totals to determine DP.

Step Five: Determine Total Tractive Effort

The Tractive Effort (TE) is the sum of the forces calculated in steps one through three above. On low speed vehicles, wind resistance can typically be neglected. However, friction in drive components may warrant the addition of 10% to the total tractive effort to insure acceptable vehicle performance.

$$\text{TE} = \text{RR} + \text{GR} + \text{FA} + \text{DP (lb or N)}$$

Example: $\text{TE} = 33 + 300 + 34 + 0 \text{ (lbs)} = 367 \text{ lbs}$

Step Six: Determine Motor Torque

The Motor Torque (T) required per motor is the Total Tractive Effort divided by the number of motors used on the machine. Gear reduction is also factored into account in this equation.

$$\text{T} = (\text{TE} \times \text{rm}) / (\text{M} \times \text{G}) \text{ Nm per motor or } \text{T} = (\text{TE} \times \text{ri}) / (\text{M} \times \text{G}) \text{ lb-in per motor}$$

M number of driving motors

Example: $\text{T} = (367 \times 16) / (2 \times 1) \text{ lb-in/motor} = 2936 \text{ lb-in}$

Step Seven: Determine Wheel Slip

To verify that the vehicle will perform as designed in regards to tractive effort and acceleration, it is necessary to calculate wheel slip (TS) for the vehicle. In special cases, wheel slip may actually be desirable to prevent hydraulic system overheating and component breakage should the vehicle become stalled.

$$\text{TS} = (\text{W} \times \text{f} \times \text{rm}) / \text{G (Nm per motor)} \text{ or } \text{TS} = (\text{W} \times \text{f} \times \text{ri}) / \text{G (lb-in per motor)}$$

Technical Information

f coefficient of friction (see *Coefficient of friction (f)* on page 9)

W loaded vehicle weight over driven wheel (lb or N)

Example: $TS = (425 \times .06 \times 16) / 1 = \text{lb-in/motor} = 4080 \text{ lbs}$

Coefficient of friction (f)

Steel on steel	0.3
Rubber tire on dirt	0.5
Rubber tire on a hard surface	0.6 - 0.8
Rubber tire on cement	0.7

To determine radial load capacity requirement of motor

When a motor used to drive a vehicle has the wheel or hub attached directly to the motor shaft, it is critical that the radial load capabilities of the motor are sufficient to support the vehicle. After calculating the Total Radial Load (RL) acting on the motors, the result must be compared to the bearing/shaft load charts for the chosen motor to determine if the motor will provide acceptable load capacity and life.

$$RL = \sqrt{W^2 + (T / r_i)^2} \text{ lb or } RL = \sqrt{W^2 + (T / r_m)^2} \text{ kg}$$

Example: $RL = \sqrt{425^2 + (2936 / 16)^2} = 463 \text{ lbs}$

Once the maximum motor RPM, maximum torque requirement, and the maximum load each motor must support have been determined, these figures may then be compared to the motor performance charts and to the bearing load curves to choose a series and displacement to fulfill the motor requirements for the application.

Induced Side Load

In many cases, pulleys or sprockets may be used to transmit the torque produced by the motor. Use of these components will create a torque induced side load on the motor shaft and bearings. It is important that this load be taken into consideration when choosing a motor with sufficient bearing and shaft capacity for the application.

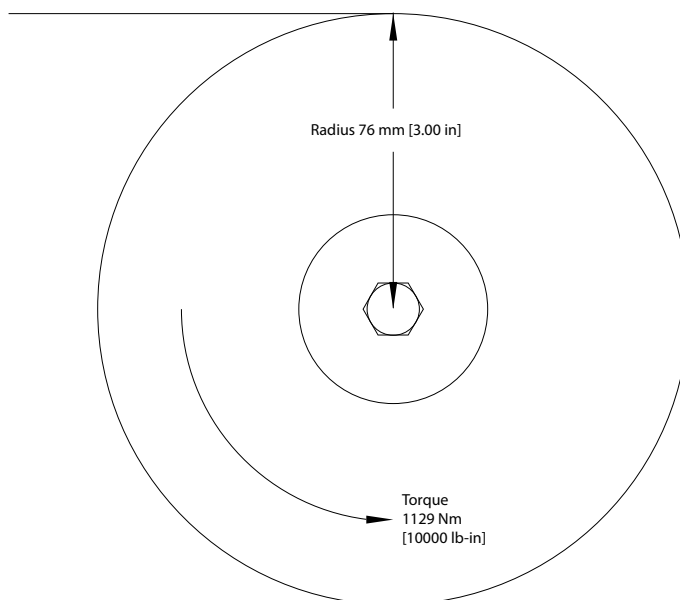

P109321

Technical Information

To determine the side load, the motor torque and pulley or sprocket radius must be known. Side load may be calculated using the formula below. The distance from the pulley/sprocket centerline to the mounting flange of the motor must also be determined. These two figures may then be compared to the bearing and shaft load curve of the desired motor to determine if the side load falls within acceptable load ranges.

$$\text{Side Load} = \frac{\text{Torque}}{\text{Radius}}$$

$$\text{Side Load} = 14855 \text{ Nm [3333 lbs]}$$

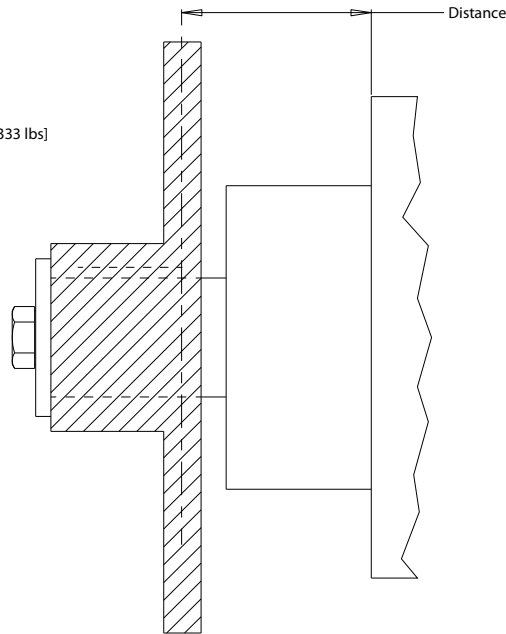

P109322

Hydraulic Equations

Multiplication Factor	Abbreviation	Prefix
10 ¹²	T	tera
10 ⁹	G	giga
10 ⁶	M	mega
10 ³	K	kilo
10 ²	h	hecto
10 ¹	da	deka
10 ⁻¹	d	deci
10 ⁻²	c	centi

- Theo. Speed (RPM)** (1000 x LPM) / Displacement (cm³/rev)
 (231 x GPM) / Displacement (in³/rev)
- Theo. Torque (lb-in)** (Bar x Disp. (cm³/rev)) / 20 pi
 (PSI x Disp. (in³/rev) / 6.28)
- Power In (HP)** (Bar x LPM) / 600
 (PSI x GPM) / 1714
- Power Out (HP)** (Torque (Nm) x RPM) / 9543

Technical Information

(Torque (lb-in) x RPM) / 63024

Shaft Nut Information

The tightening torques listed with each nut should only be used as a guideline. Hubs may require higher or lower tightening torque depending on the material. Consult the hub manufacturer to obtain recommended tightening torque. To maximize torque transfer from the shaft to the hub, and to minimize the potential for shaft breakage, a hub with sufficient thickness must fully engage the taper length of the shaft.

Hub engagement

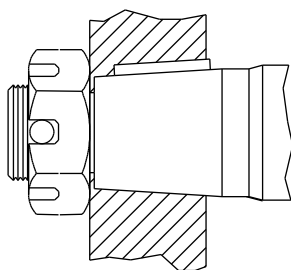

Incorrect

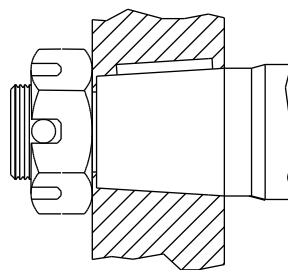

Correct

P109323

Technical Information

35MM TAPERED SHAFTS
M24 x 1.5 Thread

A Slotted Nut

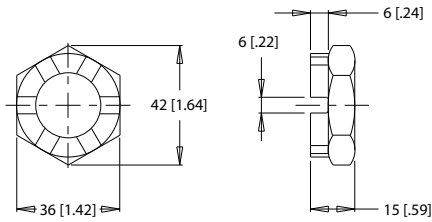

Torque Specifications: 32.5 daNm [240 ft.lb.]

1" TAPERED SHAFTS
3/4-28 Thread

A Slotted Nut

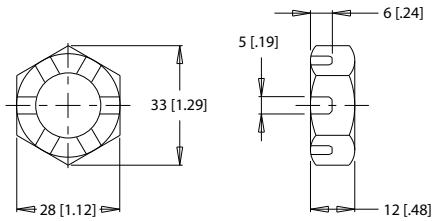

Torque Specifications: 20 - 23 daNm [150 - 170 ft.lb.]

B Lock Nut

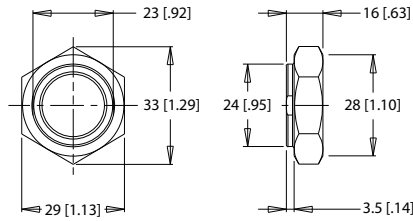

Torque Specifications: 24 - 27 daNm [180 - 200 ft.lb.]

C Solid Nut

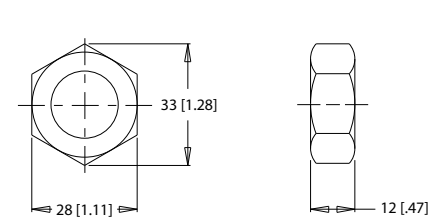

Torque Specifications: 20 - 23 daNm [150 - 170 ft.lb.]

1-1/4" TAPERED SHAFTS
1-20 Thread

A Slotted Nut

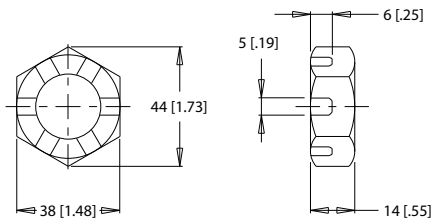

Torque Specifications: 38 daNm [280 ft.lb.] Max.

B Lock Nut

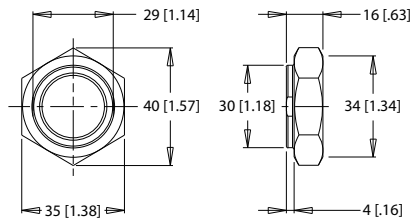

Torque Specifications: 33 - 42 daNm [240 - 310 ft.lb.]

C Solid Nut

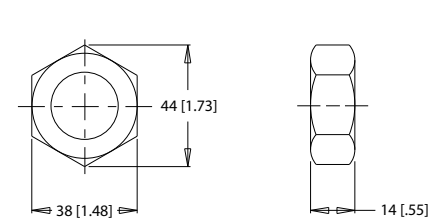

Torque Specifications: 38 daNm [280 ft.lb.] Max.

1-3/8" & 1-1/2" TAPERED SHAFTS
1 1/8-18 Thread

A Slotted Nut

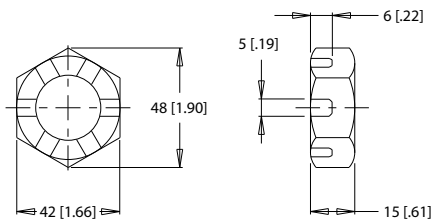

Torque Specifications: 41 - 54 daNm [300 - 400 ft.lb.]

B Lock Nut

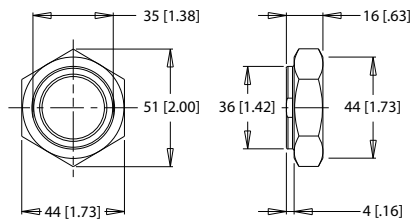

Torque Specifications: 34 - 48 daNm [250 - 350 ft.lb.]

C Solid Nut

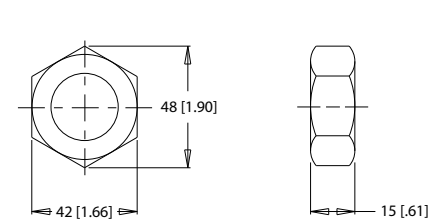

Torque Specifications: 41 - 54 daNm [300 - 400 ft.lb.]

BK 913 and 915 Series

Overview

With safety an increasingly important factor in the design and manufacture of equipment, it has become necessary to add a brake to many critical machine functions. In response to that concern, Danfoss offers BK Series brakes. Based on technology proven in Danfoss integrated motor/brakes, this spring-applied, hydraulically released brake provides up to 1500 Nm [13,300 lb-in] of holding torque for static brake applications.

Other features contribute to the superior operation and durability of the BK brakes. All internal components, including roller bearings, brake disks, springs and seals were chosen for maximum durability. To further extend the life of the unit and reduce noise, all internal components run in an oil bath. Two brake release ports are also provided to simplify plumbing and bleeding of the brake release circuit during installation. All of these features combine to make BK Series brakes a top choice for any static brake application requiring up to 1500 Nm [13,300 lb-in] of holding torque.

Features / Benefits

- Heavy-duty roller bearings support high shaft loads and provide long life.
- Dual release ports allow easier bleeding of brake release cavity.
- Oil-filled cavity immerses all components providing quiet operation and reduced wear.

Typical Applications

Wheel drives, positioners, conveyors, door openers, swing drives, aerial work platforms and more

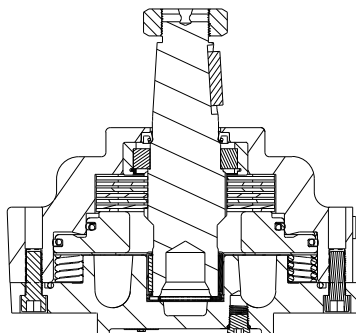

P109449

Specifications

913 Series Holding Torque	1130 Nm [10,000 lb-in]
915 Series Holding Torque	1500 Nm [13,300 lb-in]
Release Pressure	28 bar [400 psi]
Maximum Release Pressure	207 bar [3,000 psi]
Release Volume	11.5 cm ³ [0.7 in ³]
Max. Speed	250 rpm
Max. Operating Temperature	82 °C [180 °F]
Weight	16.8 kg [37 lb]
Fluid Type	Mineral based oil

BK 913 and 915 Series

BK 913 and 915 Series Housings

Dimensions shown are without paint. Paint thickness can be up to 0.13 [.005].

4-Hole, Brake Mount, Aligned Ports

4-HOLE, BRAKE MOUNT, ALIGNED PORTS

K30 7/16-20 UNF

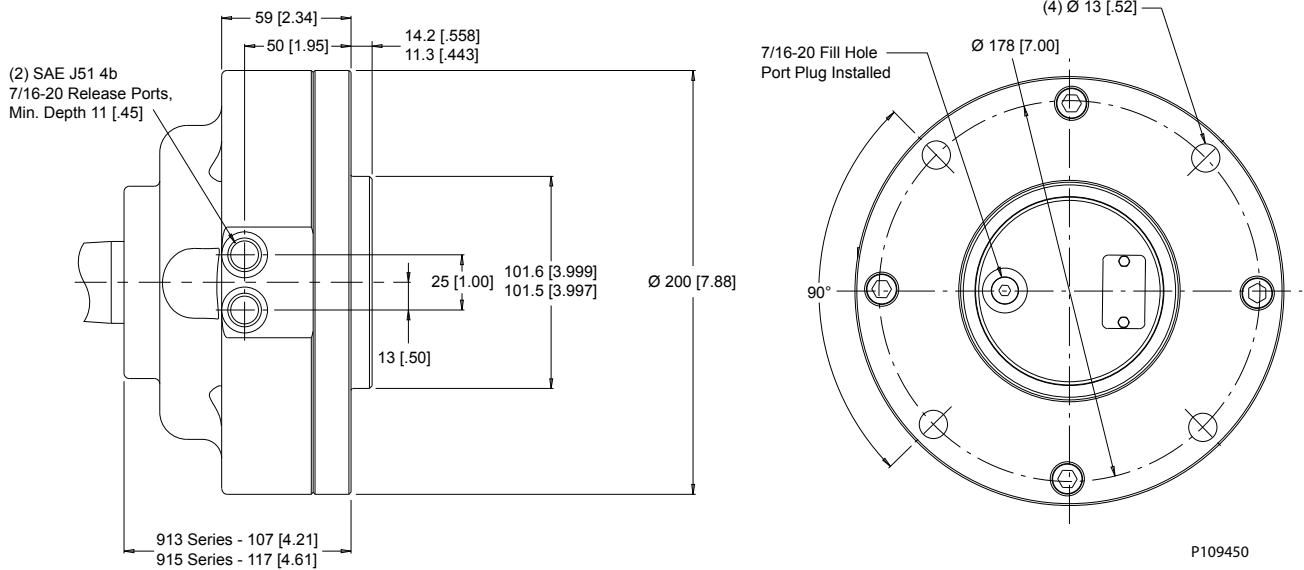

BK 913 and 915 Series Technical Information

Allowable Shaft Load / Bearing Curve

The bearing curve represents allowable bearing loads based on ISO 281 bearing capacity for an L_{10} life of 2,000 hours at 100 rpm. Radial loads for speeds other than 100 rpm may be calculated using the [Bearing Load Multiplication Factor Table](#) on page 6.

BK 913 and 915 Series

BK 913 Series Brake - Side Load Chart

913 SERIES BRAKE - SIDE LOAD CHART

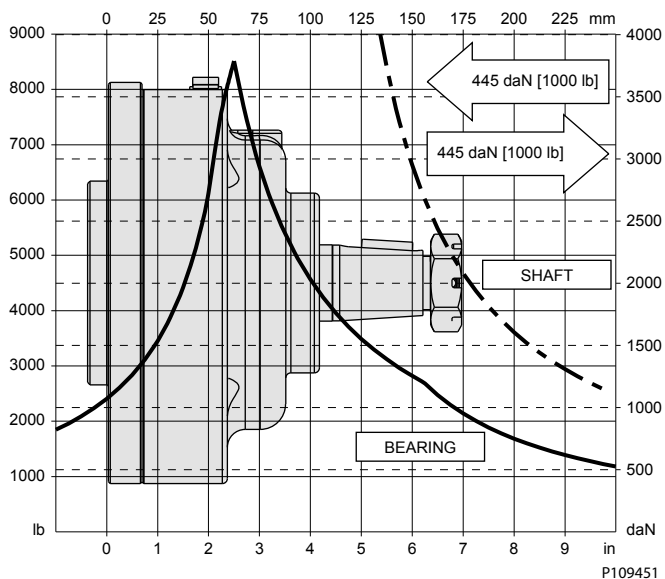

BK 915 Series Brake - Side Load Chart

915 SERIES BRAKE - SIDE LOAD CHART

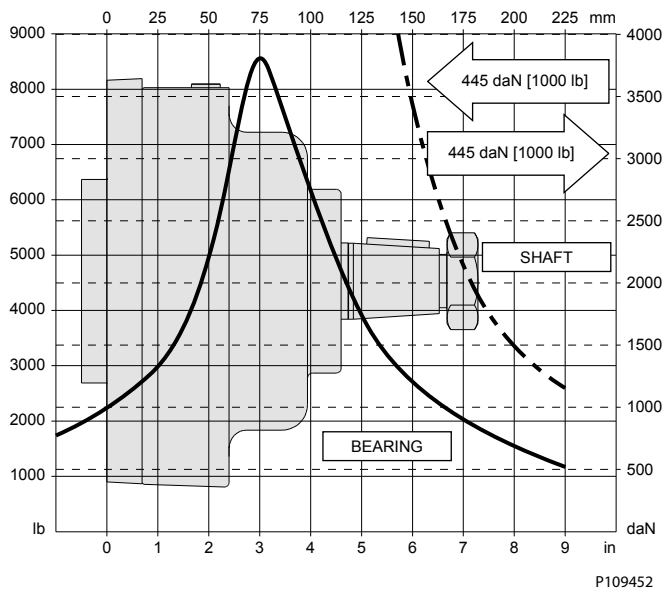

BK 913 and 915 Series

BK 913 and 915 Series Shafts

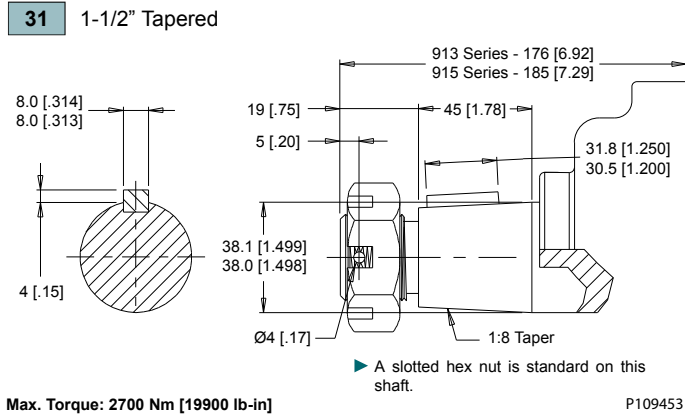

BK 913 and 915 Series Ordering Information

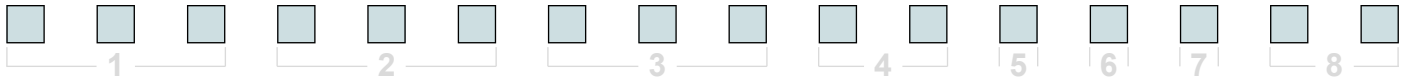

1. CHOOSE SERIES DESIGNATION

- 913** Hydraulic Brake
- 915** Hydraulic Brake

2. SELECT A HOLDING TORQUE OPTION

- 000** Standard

3. SELECT A MOUNT & PORT OPTION

- K30** 4-Hole, Brake Mount, Aligned Ports, 7/16-20 UNF

4. SELECT A SHAFT OPTION

- 31** 1-1/2" Tapered

5. SELECT A PAINT OPTION

- A** Black
- Z** No Paint

6. SELECT A VALVE CAVITY / CARTRIDGE OPTION

- A** None

7. SELECT AN ADD-ON OPTION

- A** Standard
- C** Solid Hex Nut

8. SELECT A MISCELLANEOUS OPTION

- AA** None

P109454

AB 920 Series

Overview

The AB series is a multi-wet-disc-brake that provides superior performance; all internal components are fully immersed in pre-filled fluid and are environmentally sealed to prevent contamination and corrosion while providing brake durability and maintaining proper holding capacity. Compact design and large holding torque along with a lower release pressure and lower free turn torque saves your space and reduces cost. Two brake release ports provide simple plumbing and the bleeding of the brake release circuit during installation.

Features / Benefits

- Compact design.
- Ball bearings support higher shaft loads and provide longer life shaft seal life.
- Dual release ports allow easier bleeding of brake release cavity.
- Oil-filled cavity immerses all components providing quiet operation.
- Large holding torque with lower release pressure and free turn torque.

Typical Applications

Wheel drives, positioners, conveyors, door openers, swing drives, aerial work platforms and more

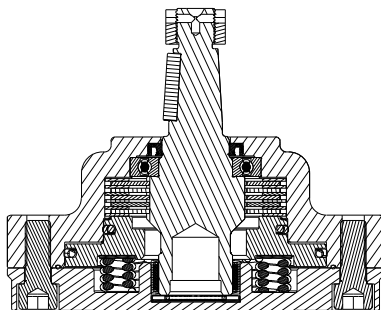

P109449

Specifications

Holding Torque	475 Nm [4,200 lb-in]
Release Pressure	20 bar [290 psi]
Maximum Release Pressure	207 bar [3,000 psi]
Release Volume	9.0 cm ³ [0.55 in ³]
Max. Speed	250 rpm
Max. Operating Temperature	82 °C [180 °F]
Weight	9.25 kg [20.4 lb]
Fluid Type	Mineral based oil

AB 920 Series Housings

Dimensions shown are without paint. Paint thickness can be up to 0.13 [.005].

AB 920 Series

4-Hole, Brake Mount

4-HOLE, BRAKE MOUNT

K30 7/16-20 UNF

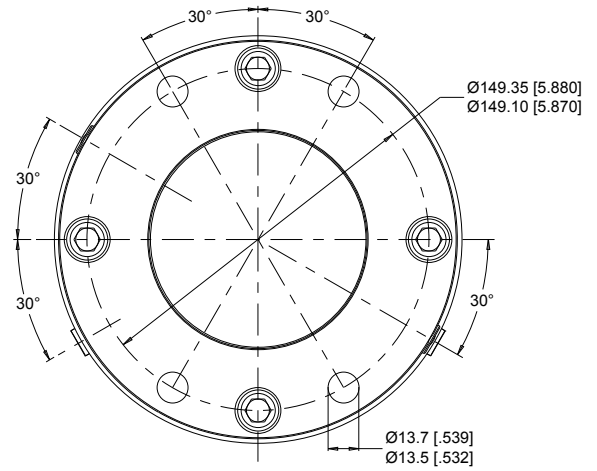
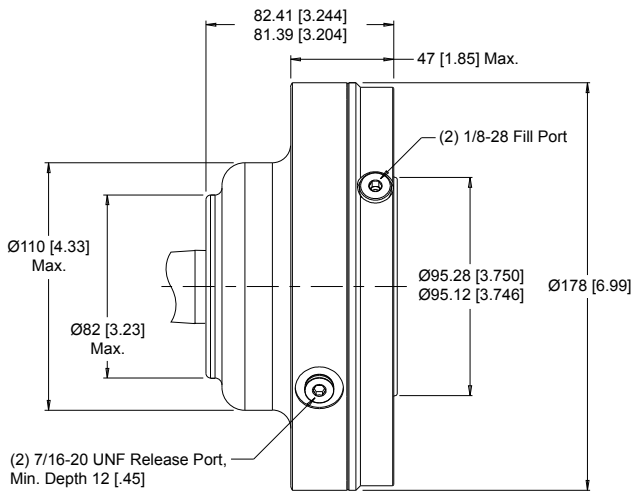

P109456

AB 920 Series Technical Information

Allowable Shaft Load / Bearing Curve

The bearing curve represents allowable bearing loads based on ISO 281 bearing capacity for an L_{10} life of 2,000 hours at 100 rpm. Radial loads for speeds other than 100 rpm may be calculated using the [Bearing Load Multiplication Factor Table](#) on page 6.

AB 920 Series Brake - Side Load Chart

920 SERIES BRAKE - SIDE LOAD CHART

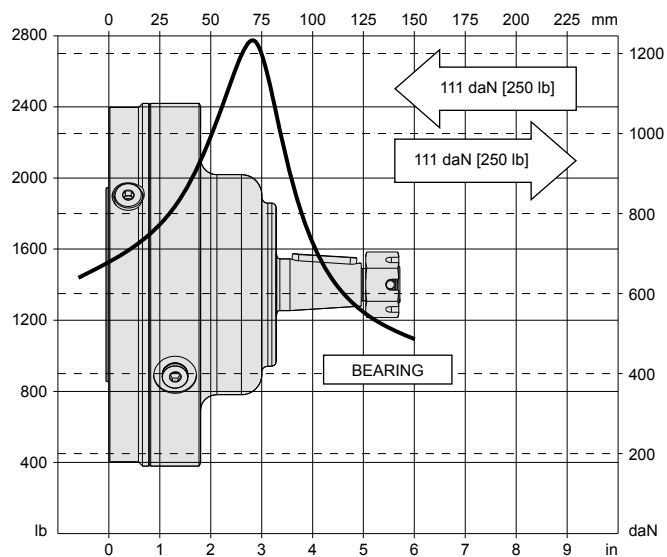

P109457

AB 920 Series

AB 920 Series Shafts

13 1" Tapered

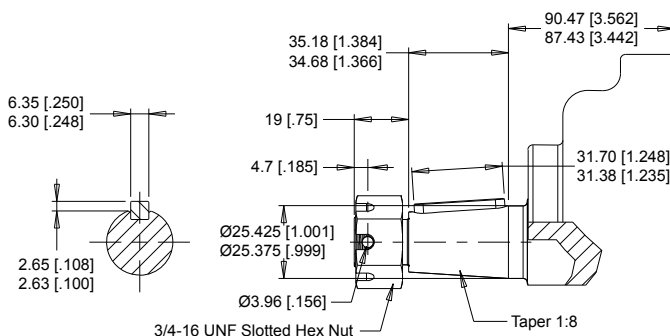

22 1-1/4" Tapered

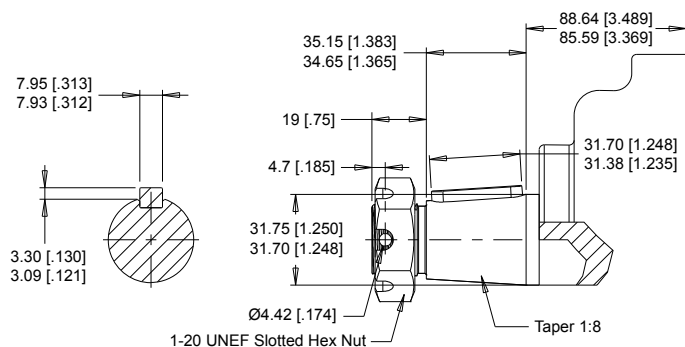

P109458

AB 920 Series Ordering Information

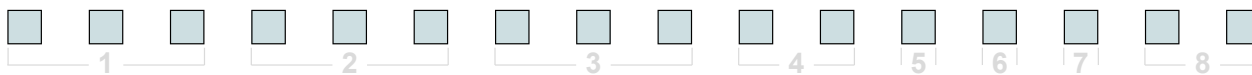

1. CHOOSE SERIES DESIGNATION

920 Hydraulic Brake

2. SELECT A HOLDING TORQUE OPTION

000 475 Nm [4200 lb-in]

3. SELECT A MOUNT & PORT OPTION

K30 4-Hole, Brake Mount, 7/16-20 UNF

4. SELECT A SHAFT OPTION

13 1" Tapered

22 1-1/4" Tapered

5. SELECT A PAINT OPTION

A Black

B Black, Unpainted Mounting Surface

6. SELECT A VALVE CAVITY / CARTRIDGE OPTION

A None

7. SELECT AN ADD-ON OPTION

A Standard

8. SELECT A MISCELLANEOUS OPTION

AA 1.50 [.060] Pilot Height (Standard)

AY 3.18 [.125] Pilot Height

AZ 6.35 [.250] Pilot Height

TC Single Throttle Valve With Standard Pilot Height

TD Two Throttle Valves With Standard Pilot Height

P109459

FB 925 Series

Overview

The FB series is a multi-wet-disc-brake that provides superior performance; all internal components are fully immersed in pre-filled fluid and are environmentally sealed to prevent contamination and corrosion while providing brake durability and maintaining proper holding capacity. Compact design and large holding torque along with a lower release pressure and lower free turn torque saves your space and reduces cost.

Features / Benefits

- Compact design.
- Heavy-duty roller bearings support higher shaft loads and provide longer life shaft seal life.
- Oil-filled cavity immerses all components providing quiet operation.
- Large holding torque with lower release pressure and free turn torque.

Typical Applications

Wheel drives, positioners, conveyors, door openers, swing drives, aerial work platforms and more

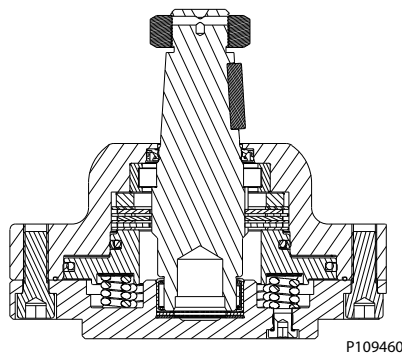

Specifications

Release Pressure	20 bar [290 psi]
Maximum Release Pressure	207 bar [3,000 psi]
Release Volume	9.0 cm ³ [0.55 in ³]
Max. Speed	250 rpm
Max. Operating Temperature	82 °C [180 °F]
Weight	10.9 kg [24 lb]
Fluid Type	Mineral based oil

FB 925 Series Housings

Dimensions shown are without paint. Paint thickness can be up to 0.13 [.005].

FB 925 Series

4-Hole, Brake Mount

4-HOLE, BRAKE MOUNT

K30 7/16-20 UNF

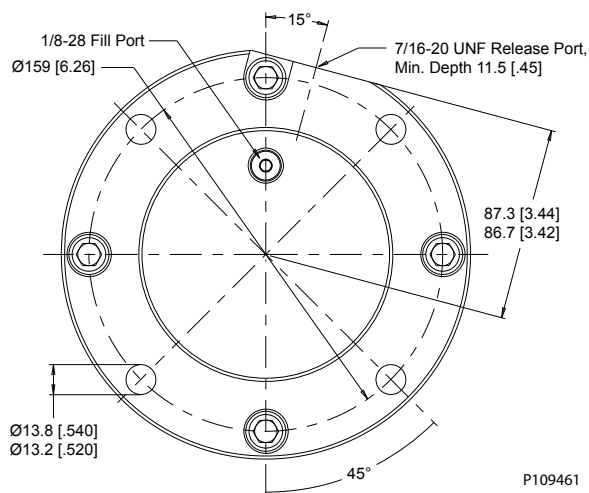
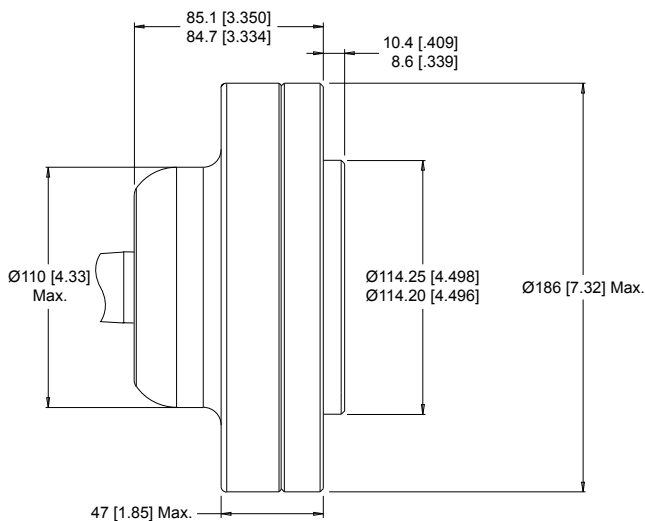

FB 925 Series Technical Information

Allowable Shaft Load / Bearing Curve

The bearing curve represents allowable bearing loads based on ISO 281 bearing capacity for an L_{10} life of 2,000 hours at 100 rpm. Radial loads for speeds other than 100 rpm may be calculated using the [Bearing Load Multiplication Factor Table](#) on page 6.

FB 925 Series Brake - Side Load Chart

925 SERIES BRAKE - SIDE LOAD CHART

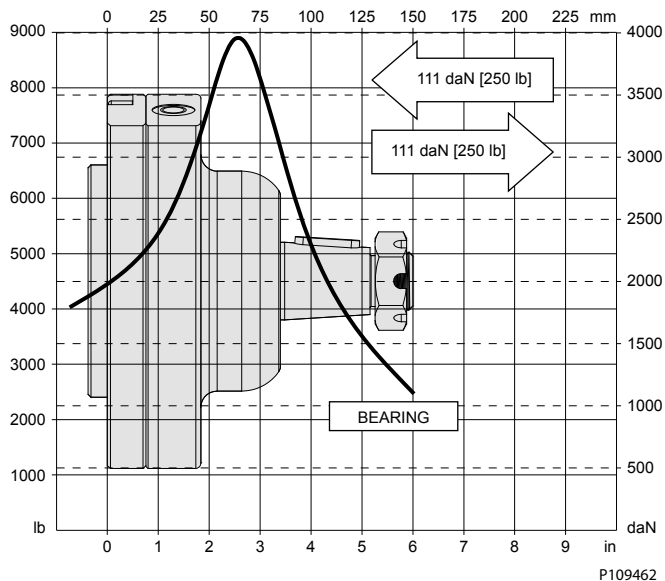

FB 925 Series

FB 925 Series Shafts

31 1-1/2" Tapered

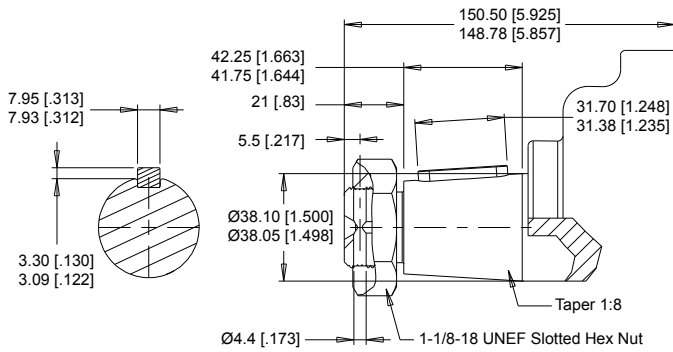

D7 32mm Tapered

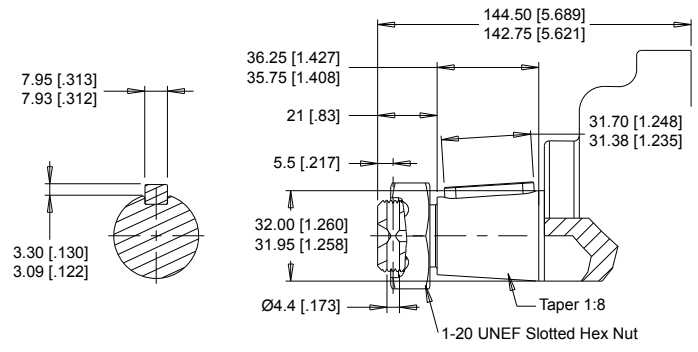

P109463

FB 925 Series Ordering Information

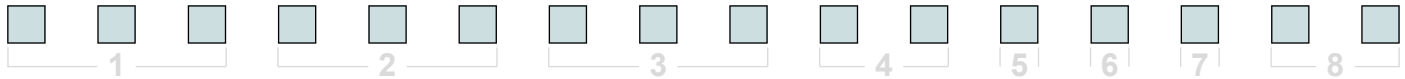

1. CHOOSE SERIES DESIGNATION

925 Hydraulic Brake

2. SELECT A HOLDING TORQUE OPTION

350 350 Nm [3100 lb-in]

550 550 Nm [4900 lb-in]

650 650 Nm [5750 lb-in]

3. SELECT A MOUNT & PORT OPTION

K30 4-Hole, Brake Mount, 7/16-20 UNF

4. SELECT A SHAFT OPTION

31 1-1/2" Tapered

D7 32mm Tapered

5. SELECT A PAINT OPTION

A Black

B Black, Unpainted Mounting Surface

6. SELECT A VALVE CAVITY / CARTRIDGE OPTION

A None

7. SELECT AN ADD-ON OPTION

A Standard

8. SELECT A MISCELLANEOUS OPTION

AA None

P109464

SB 930 Series

Overview

The SB Series is a multiple-wet-disc-brake that provides superior performance in an extremely compact package. Unlike conventional brakes offered today, the SB brake is performance-matched to fit the full range of small-frame SAE A mount motors available today. With an overall diameter of less than 137mm [5.4 in] the SB has a holding capacity in excess of 620 Nm [5,500 lb-in] and is easily mated to a variety of global industry standard motor mounting and shaft options. In addition, the SB Series can be used as a stand-alone brake solution without an input drive motor. This option further opens design flexibility to meet a wider variety of application needs.

Features / Benefits

- All wear components are fully immersed in fluid (wet multi-disc design)
- Performance-matched to fit small-frame motors with SAE A mounts
- Release pressure independent of motor pressure
- Brake directly coupled to the output shaft
- Wide-variety of input and output shaft options
- Environmentally sealed / factory prefilled with oil
- Proven, Quiet, Trouble-Free Operation
- Compact, Cost-Effective Package
- Simplifies System Circuits - Eliminates Need for Pressure- Reducing Valve
- Series Operating Capability
- Reliable Performance - Fewer Critical Components
- Design Flexibility
- Global Interchangeability
- Suited for "Stand Alone" Brake Applications
- Ease of Installation

Typical Applications

Wheel drives, positioners, conveyors, door openers, swing drives, aerial work platforms and more

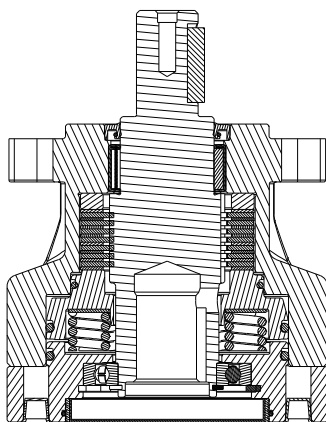

P109465

SB 930 Series

Specifications

Code	225	315	415	520	620
Holding Torque	225 Nm [2,000 lb-in]	315 Nm [2,800 lb-in]	415 Nm [3,700 lb-in]	520 Nm [4,600 lb-in]	620 Nm [5,500 lb-in]
Max. Release Pressure	207 bar [3,000 psi]	207 bar [3,000 psi]	207 bar [3,000 psi]	207 bar [3,000 psi]	207 bar [3,000 psi]
Full Release Pressure	23 bar [330 psi]	23 bar [330 psi]	23 bar [330 psi]	36 bar [520 psi]	36 bar [520 psi]
Release Volume	8.3 cm ³ [.51 in ³]	8.3 cm ³ [.51 in ³]	8.3 cm ³ [.51 in ³]	8.3 cm ³ [.51 in ³]	8.3 cm ³ [.51 in ³]
Max. Speed	250 rpm	250 rpm	250 rpm	250 rpm	250 rpm
Unit Weight	8 kg [17.6 lb]	8 kg [17.6 lb]	8 kg [17.6 lb]	8 kg [17.6 lb]	8 kg [17.6 lb]

SB 930 Series Housings

Dimensions shown are without paint. Paint thickness can be up to 0.13 [.005].

2-HOLE, SAE A BRAKE MOUNT

A10 7/16-20 UNF **A11** G 1/4

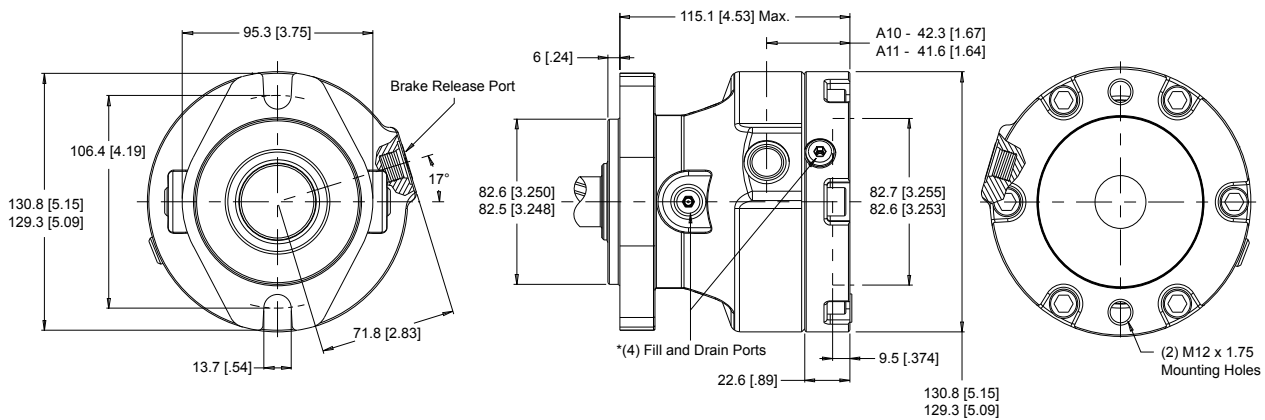

4-HOLE, SAE A BRAKE MOUNT

A30 7/16-20 UNF **A31** G 1/4

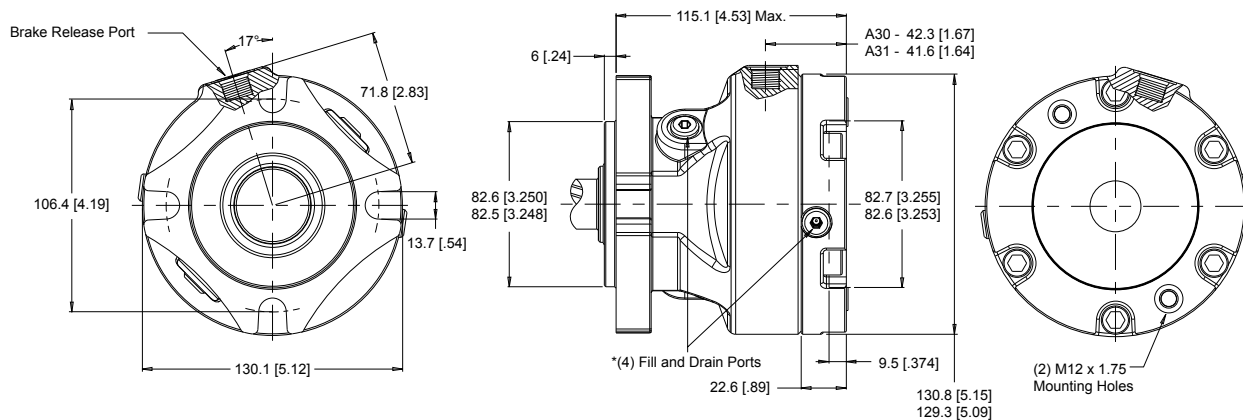

► Cast Dimensions are ± 0.8 mm [.030 in.] *Fill and drain ports for filling and draining the brake only. No system connections are to be made to the fill and drain ports. These ports are not suitable for use in a cooling loop.

P109466

SB 930 Series

Cast Dimensions are ± 0.8 mm [.030 in.] *Fill and drain ports for filling and draining the brake only.
 No system connections are to be made to the fill and drain ports. These ports are not suitable for use in a cooling loop.

SB 930 Series Shafts

ZW 1" Straight, 6B Input

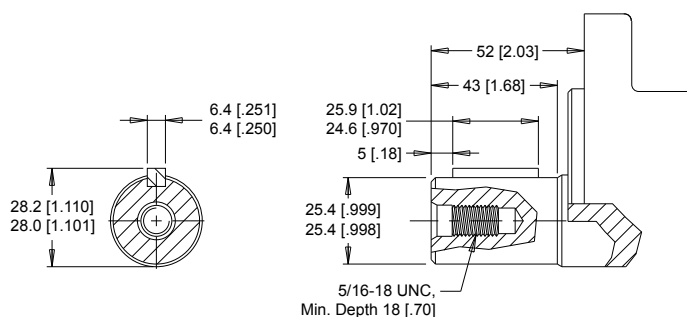

ZY 25mm Straight, 25mm Input **ZT** 25mm Straight, 6B Input

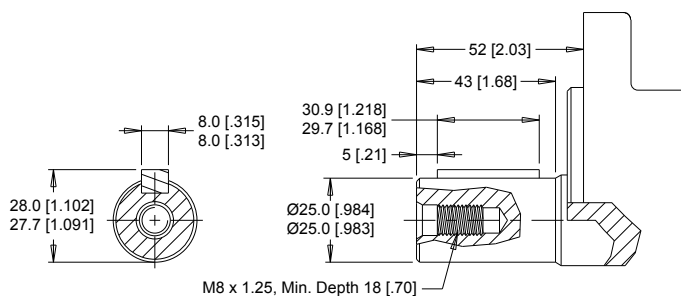

ZX 32mm Straight, 25mm Input **ZU** 32mm Straight, 6B Input

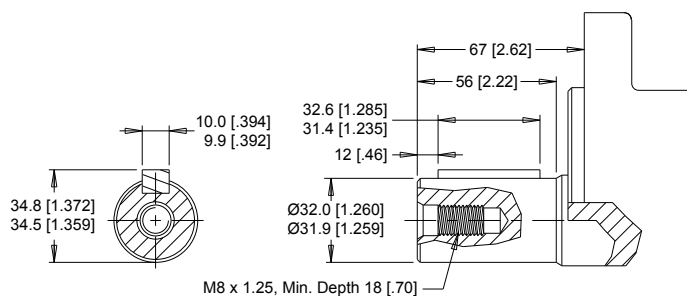

ZZ 6B Spline, 6B Input

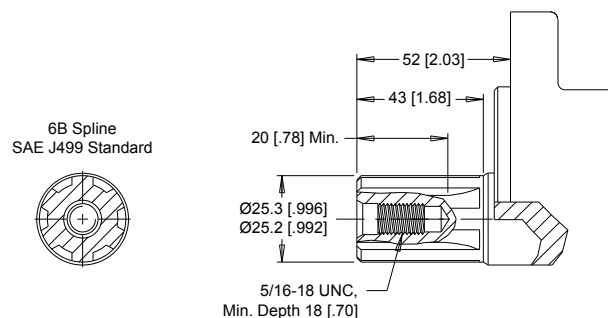

6B INPUT DIMENSIONS

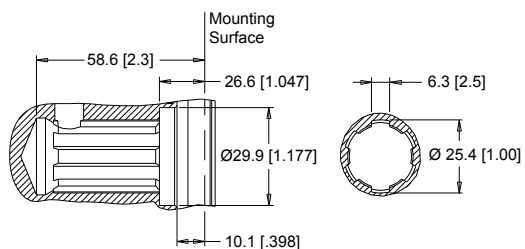

25MM INPUT DIMENSIONS

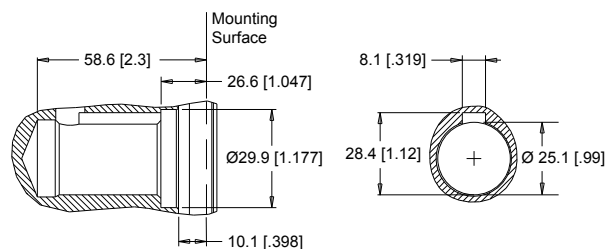

SB 930 Series

SB 930 Series Technical Information

Allowable Shaft Load / Bearing Curve

The bearing curve represents allowable bearing loads based on ISO 281 bearing capacity for an L_{10} life of 2,000 hours at 100 rpm. Radial loads for speeds other than 100 rpm may be calculated using the [Bearing Load Multiplication Factor Table](#) on page 6.

SB 930 Series Brake - Side Load Chart

930 SERIES BRAKE - SIDE LOAD CHART

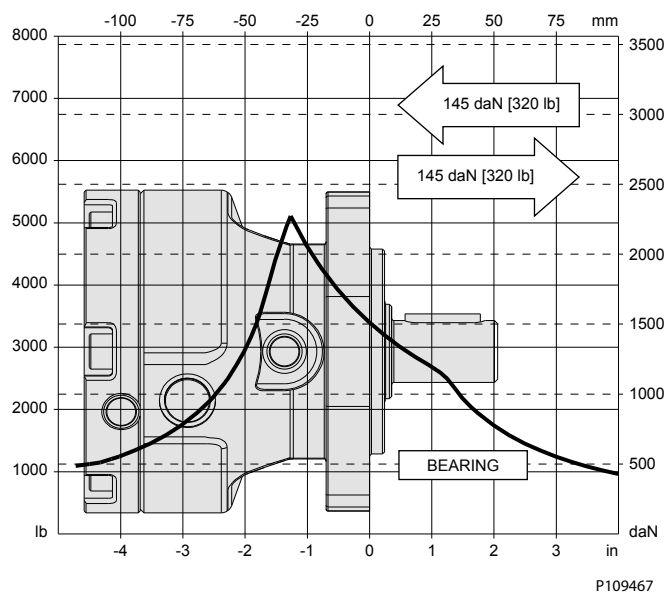

SB 930 Series Installation Information

The SB Brake is a wet multi-disc type static brake and is shipped factory filled with fluid. The fluid used is a standard SAE 20 hydraulic fluid. A hydraulic motor can be mounted to the SB Brake to provide a complete motor/brake package. A shipping cover protects and seals the input interface until it is ready for installation. The shipping cover is removed by removing the two cap screws and following the motor installation procedure below. Mounting pilot surfaces need to be free of paint or other substances for proper assembly and leak-free performance. Standard SB brakes are sold unpainted with an easy to remove shipping cover. Stand-alone SB brakes come standard painted and factory installed cover.

The input interface must be sealed to keep the brake environmentally protected and bearings fully immersed in fluid for proper lubrication and long life. Standard SAE 20 hydraulic oil is used in the brake cavity as well as typically used in hydraulic systems.

An internal seal is provided to seal long-pilot motors. When a short-pilot motor is used, an o-ring face seal is needed to properly seal the motor/brake interface. Two mounting bolts (M12 x 1.75 thread) and an o-ring seal with mounting instructions are included in the brake installation kit 930999001 and shipped with each SB Brake.

SB 930 Series

930 Series Brake Installation

930 SERIES BRAKE INSTALLATION

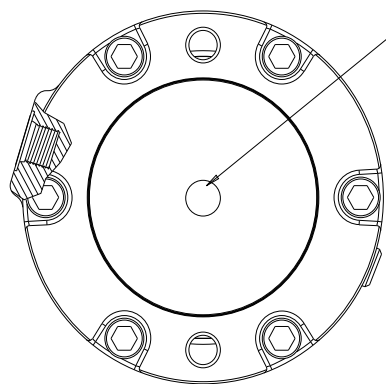

To remove cover, pierce and pry with a sharp awl.
When using the 930 Series as a Stand-Alone unit, this cover is not to be removed. It retains oil needed to lubricate the bearings.

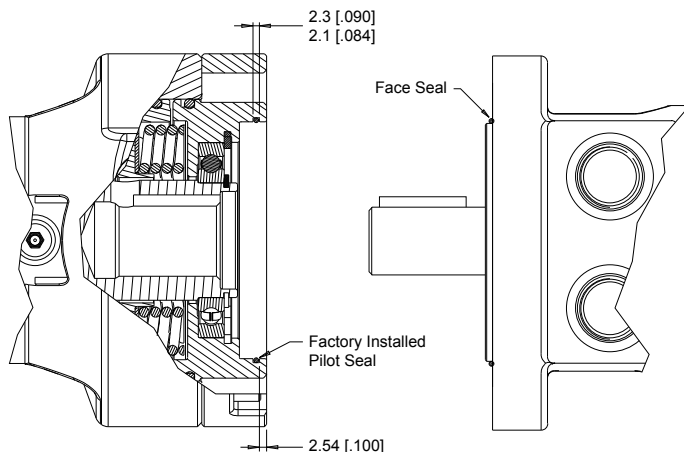

► The factory installed pilot seal may be left in place. However, this seal will not provide proper sealing for motors with short pilot mounts, therefore, the face seal contained in the mounting kit must be used.

P109470

The factory installed pilot seal may be left in place. However, this seal will not provide proper sealing for motors with short pilot mounts, therefore, the face seal contained in the mounting kit must be used.

SB 930 Series Ordering Information



1. CHOOSE SERIES DESIGNATION

930 Hydraulic Brake

2. SELECT A HOLDING TORQUE

225 225 Nm [2000 lb-in]	520 520 Nm [4600 lb-in]
315 315 Nm [2800 lb-in]	620 620 Nm [5500 lb-in]
415 415 Nm [3700 lb-in]	

3. SELECT A MOUNT & PORT OPTION

A10 2-Hole, SAE A Brake Mount, 7/16-20 UNF
A11 2-Hole, SAE A Brake Mount, G 1/4
A30 4-Hole, SAE A Brake Mount, 7/16-20 UNF
A31 4-Hole, SAE A Brake Mount, G 1/4

4. SELECT A SHAFT OPTION

ZT 25mm Straight, 6B Input	ZX 32mm Straight, 25mm Input
ZU 32mm Straight, 6B Input	ZY 25mm Straight, 25mm Input
ZW 1" Straight, 6B Input	ZZ 6B Spline, 6B Input

5. SELECT A PAINT OPTION

A Black
B Black, Unpainted Mounting Surface
Z No Paint

6. SELECT A VALVE CAVITY / CARTRIDGE OPTION

A None

7. SELECT AN ADD-ON OPTION

A Standard

8. SELECT A MISCELLANEOUS OPTION

AA Standard

P109469

RP 960 Series

Overview

The 960 Series is a device designed to replace existing, costly and complicated hydraulic brake release hand pumps that are present on various types of mobile equipment. It is typically used to release various types of spring applied/ hydraulically released brakes. Depending on the brake, typically 1-5 pumps of the 960 will release the brake. This enables equipment to be moved to a service area or a recharge/refuel station.

To operate, the equipment operator must depress the valve rod until it is firmly seated. The operator must then pump the pump rod until the brakes are released. If the hydraulic circuit is pressurized at any time during or after the 960 has released the brakes, the valve rod will automatically pop out and the mobile equipment will revert to its normal operation. This serves as a built in safety feature that ensures the equipment's normal braking operation is never accidentally disabled.

The 960 is a simplified product compared to competitive brands that are currently available. In addition, the product is a cost competitive alternative that offers superior performance and design flexibility.

Specifications

- Typical output flow 1cm³ [.06 in³] - 2cm³ [.12 in³] per stroke depending upon oil viscosity, speed of stroke, and pressure.
- Maximum working pressure of 276 bar [4000 psi].

Schematic

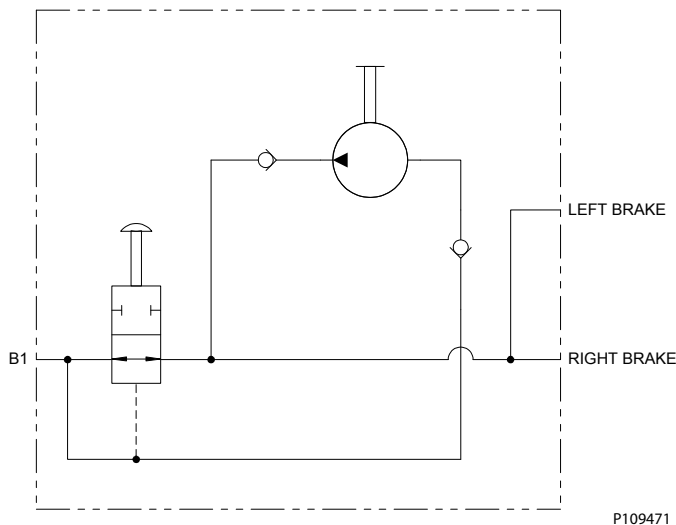

RP 960 Series

RP 960 Series Ordering Information

ORDER CODES

960020A10AAAA

960020A11AAAA

960020A12AAAA

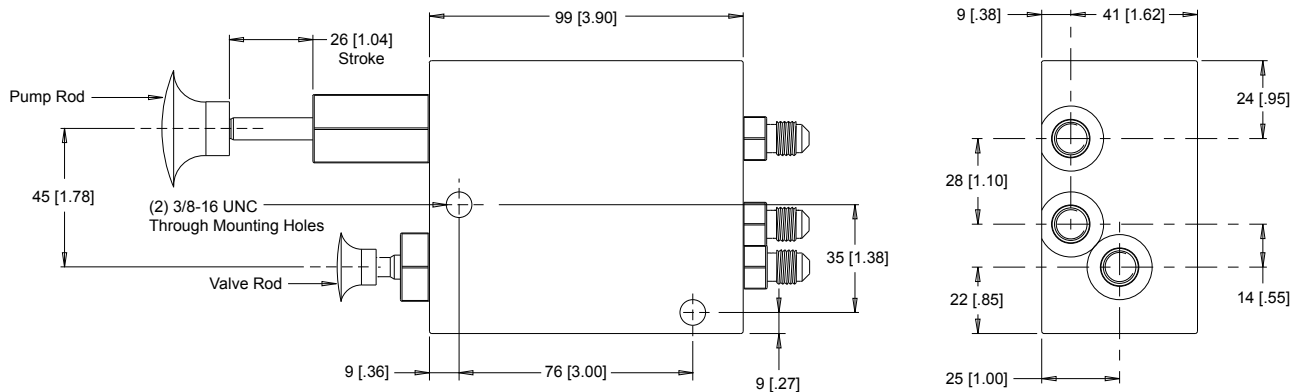

► The 960020A10AAAA has 7/16-20 UNF Ports. The 960020A11AAAA has #4 JIC fittings pre-installed. The 960020A12AAAA has G 1/4 Ports.

P109472

Products we offer:

- DCV directional control valves
- Electric converters
- Electric machines
- Electric motors
- Hydrostatic motors
- Hydrostatic pumps
- Orbital motors
- PLUS+1® controllers
- PLUS+1® displays
- PLUS+1® joysticks and pedals
- PLUS+1® operator interfaces
- PLUS+1® sensors
- PLUS+1® software
- PLUS+1® software services, support and training
- Position controls and sensors
- PVG proportional valves
- Steering components and systems
- Telematics

Danfoss Power Solutions is a global manufacturer and supplier of high-quality hydraulic and electric components. We specialize in providing state-of-the-art technology and solutions that excel in the harsh operating conditions of the mobile off-highway market as well as the marine sector. Building on our extensive applications expertise, we work closely with you to ensure exceptional performance for a broad range of applications. We help you and other customers around the world speed up system development, reduce costs and bring vehicles and vessels to market faster.

Danfoss Power Solutions – your strongest partner in mobile hydraulics and mobile electrification.

Go to www.danfoss.com for further product information.

We offer you expert worldwide support for ensuring the best possible solutions for outstanding performance. And with an extensive network of Global Service Partners, we also provide you with comprehensive global service for all of our components.

Hydro-Gear

www.hydro-gear.com

Daikin-Sauer-Danfoss

www.daikin-sauer-danfoss.com

Local address:

**Danfoss
Power Solutions (US) Company**
2800 East 13th Street
Ames, IA 50010, USA
Phone: +1 515 239 6000

**Danfoss
Power Solutions GmbH & Co. OHG**
Krokamp 35
D-24539 Neumünster, Germany
Phone: +49 4321 871 0

**Danfoss
Power Solutions ApS**
Nordborgvej 81
DK-6430 Nordborg, Denmark
Phone: +45 7488 2222

**Danfoss
Power Solutions Trading
(Shanghai) Co., Ltd.**
Building #22, No. 1000 Jin Hai Rd
Jin Qiao, Pudong New District
Shanghai, China 201206
Phone: +86 21 3418 5200

Danfoss can accept no responsibility for possible errors in catalogues, brochures and other printed material. Danfoss reserves the right to alter its products without notice. This also applies to products already on order provided that such alterations can be made without subsequent changes being necessary in specifications already agreed. All trademarks in this material are property of the respective companies. Danfoss and the Danfoss logotype are trademarks of Danfoss A/S. All rights reserved.