

Technical Information

Module Valve Block

MVB10

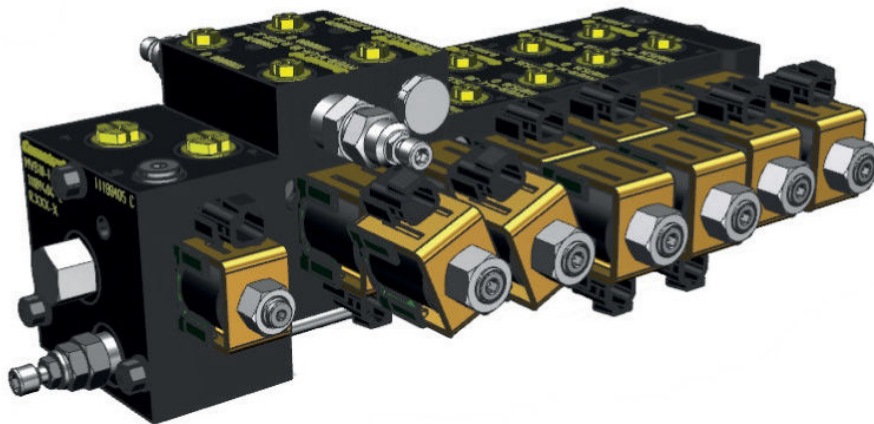

Revision history

Table of revisions

Date	Changed	Rev
September 2020	Rebranded to Danfoss	0101

Contents

MVB10 Module HIC System

MVB10 technical data.....	4
System configuration guidelines.....	5

Inlet module

MVB10-I-LS.....	7
MVB10-I.....	9
Inlet module component selection.....	11

Interface module

MVB10-IF.....	13
---------------	----

Working module

MVB10-W.....	15
MVB10-W-C.....	17
MVB10-W-LH with counterbalance valves.....	19
MVB10-W-LH with pilot check valves.....	21
MVB10-W-C-LH with counterbalance valves.....	24
MVB10-W-C-LH with pilot check valves.....	27
MVB10-W-F.....	29
MVB10-W-F-LH with counterbalance valves.....	31
MVB10-W-F-LH with pilot check valves.....	34
Working module component selection.....	37

End module

MVB10-E.....	40
--------------	----

Tie rod kits (seals included)

MVB10 Module HIC System

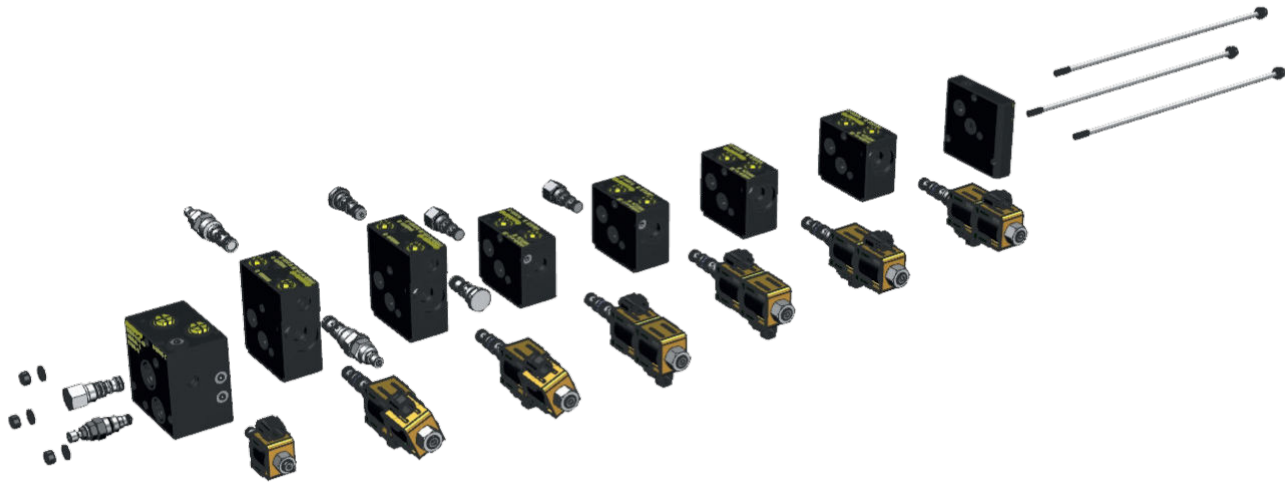

Danfoss has a range of modular HICs developed to match 40 years of experience in HIC and cartridge design with today's market request of compact and flexible solutions. The Danfoss MVB10 system is designed for the electro-hydraulic control of mobile machines for performance up to 80 l/min inlet flow and 210 bar working pressure, rated to 1 million cycles according to the NFPA T2.6.1 endurance test.

The modularity concept enables machine developers to create flexible hydraulic control solutions with standard components, ensuring the best speed to market is achieved with a high quality product. Moreover, MVB10 is completely configurable, allowing end customers to apply standard, cost effective solutions in applications.

The MVB10 also offers the flexibility to easily expand with optional features, thus reducing stock value while increasing technical and logistic flexibility. MVB10 offers a unique synergy with Danfoss PVG 16 and PVG 32 through an available interface module that allows the two products to be used in combination while using common hardware. This capability unlocks a whole new and exciting potential for tailor-made solutions that can match exactly the increasingly demanding the hydraulic controls market.

MVB10 technical data

General technical data

Ambient temperature	-25° C to + 50° C
Input flow max	80 l/min [21.1 US gal/min]
Working section rated flow	22 l/min [5 US gal/min]
Load operating max pressure*	210 bar [3045 psi]
Tank peak pressure*	210 bar [3045 psi]
Oil temperature	NBR seals: -40° C to 100° C [-40° F to 212° F]
	VITON seals: -26° C to 204° C [-15° F to 400° F]
Oil absolute viscosity limits	12-400 cSt [66-1854 SUS]
Oil recommended viscosity	12-54 cSt [66-250 SUS]
Permissible oil types	See Danfoss documents <i>Hydraulic Fluids and Lubricants</i> (BC152886484524) and <i>Biodegradable Hydraulic Fluids Applications</i> (520L0465)
Oil cleanliness	ISO 4406: 18/17/13 or better
Maximum number of sections	10 (for more, consult your Danfoss representative)
Surface treatment	Manifolds: black anodized
	Cartridges: zinc plated

* Rated pressure based on NFPA fatigue test standards (at 1 Million Cycles)

MVB10 Module HIC System

System configuration guidelines

Every MVB assembly is composed of the following base parts:

- An inlet section or a PVG 32/16 interface
- One or more work sections
- An end plate

Work sections are available with the following functions:

- On-off
- On-off with integrated load holding
- Proportional compensated
- Proportional compensated with integrated load holding*

Configuration example 1

3-function assembly for fixed displacement pump with 1 on-off directional controlled section, 1 proportional section, 1 proportional section with load holding function. System is provided with a shut-off valve, a relief valve and a logic element to bypass excessive flow. Proportional sections are locally compensated.

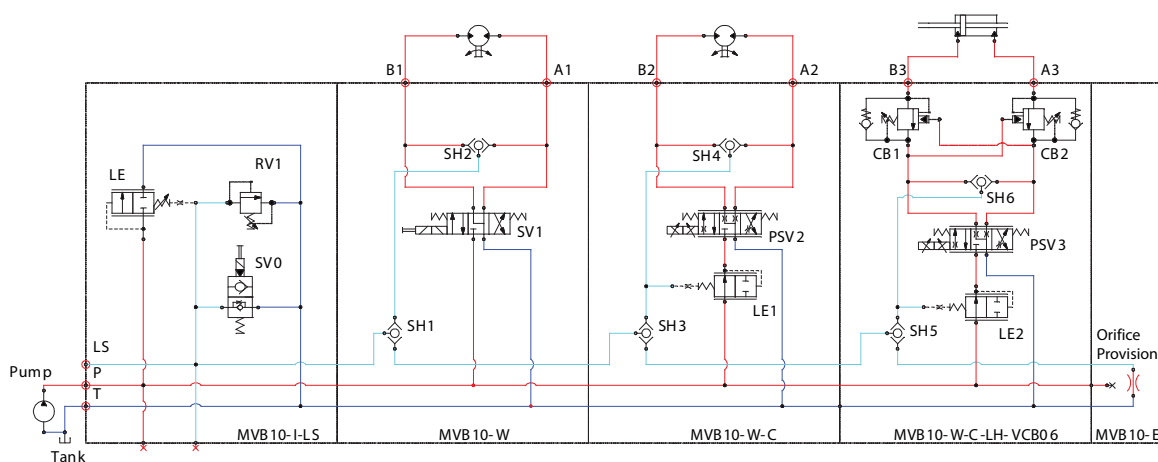

* Load holding module allows the use of either counterbalance or pilot operated check valves

MVB10 Module HIC System

Configuration example 2

3-function assembly for LS pump with 1 on-off directional controlled section, 1 proportional section and 1 on-off section with load holding. Proportional sections are locally compensated.

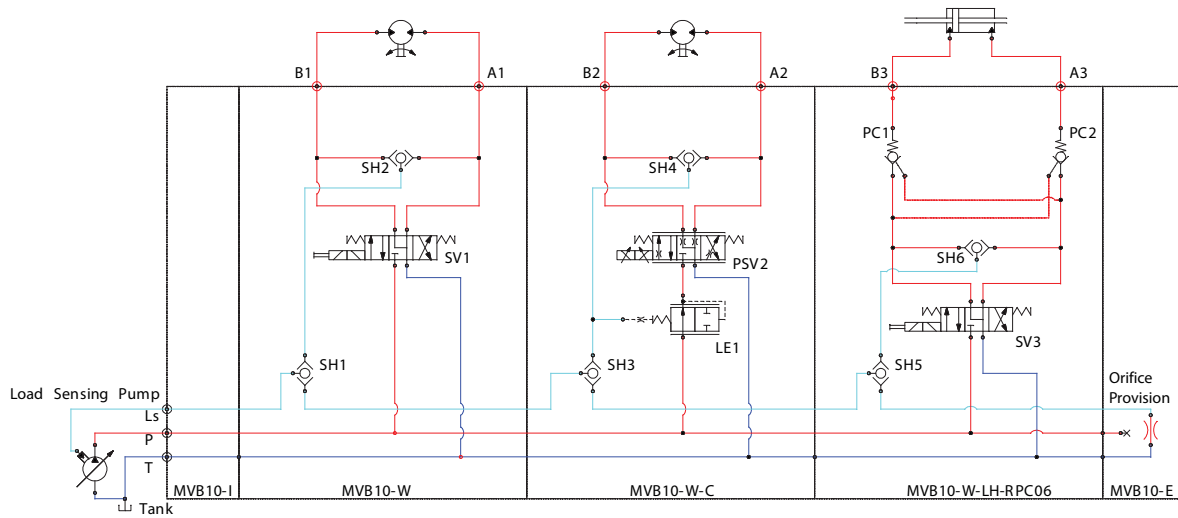

Inlet module

MVB10-I-LS

Operation



This inlet module is designed to operate in systems using either a fixed or variable displacement pump. Threaded ports are provided for external connection to the P, T and LS lines.

For applications with a fixed pump, the enable valve (SV) will allow all flow to bypass to tank at low pressure when de-energized. When energized, a logic element (LE) is used to efficiently bypass excess flow not used by the work sections to tank. The included LS relief valve (RV) limits the overall system pressure. This inlet section can also be configured to be applied with a variable displacement pump by replacing the logic element (LE) with a closed cavity plug (CP10-B- 3S-B).

Inlet module with compensation, relief and enable valve

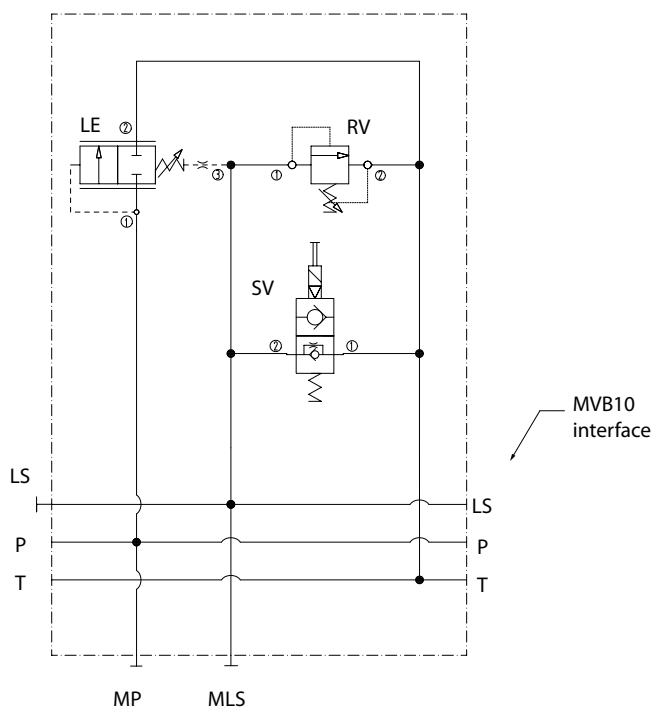

Inlet module

MVB10-I-LS dimension drawing

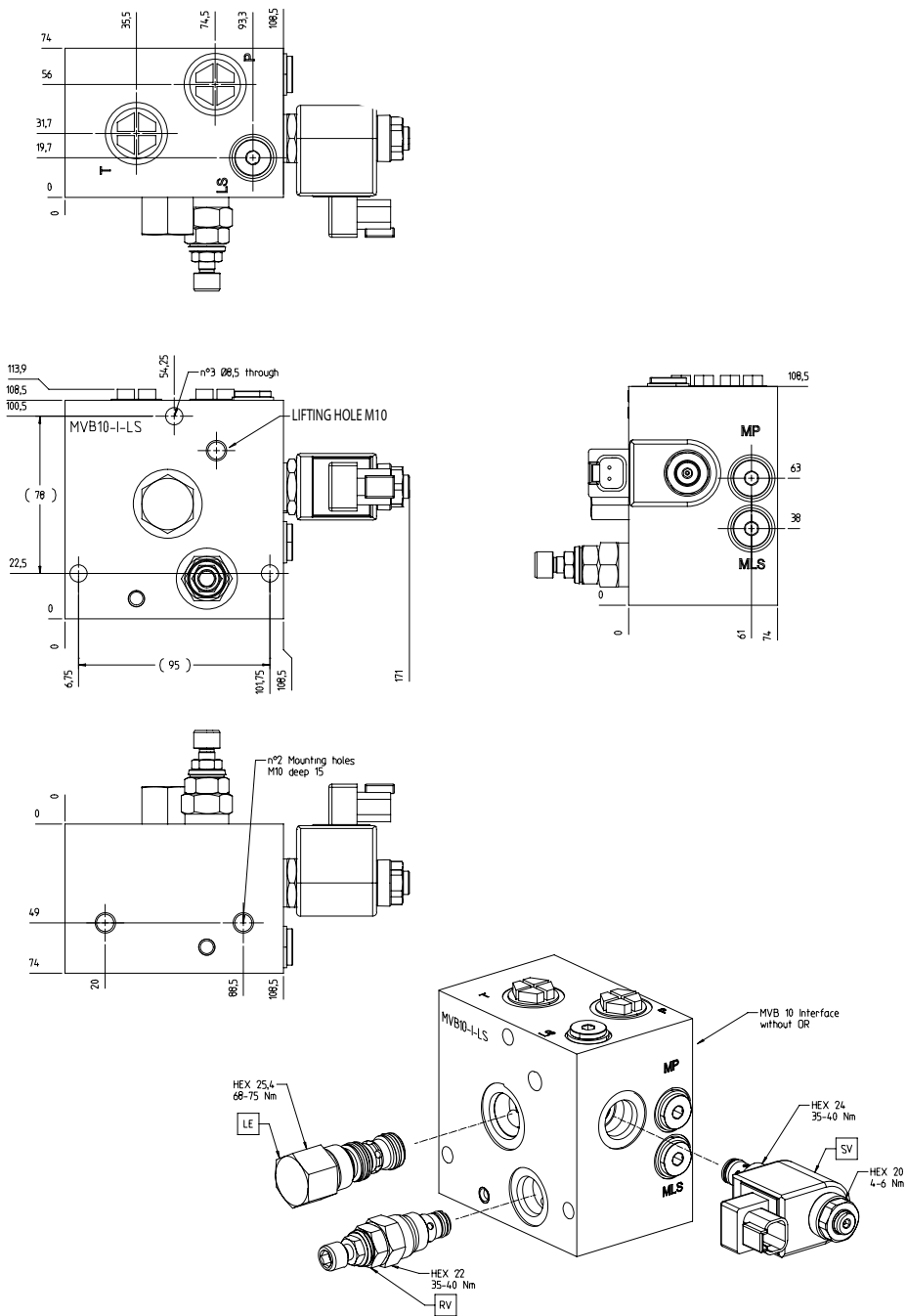

Inlet module

MVB10-I

Operation



This inlet module provides standard port connections to the P, T and LS lines in the MVB10 stack. It does not include any active components.

Standard inlet module

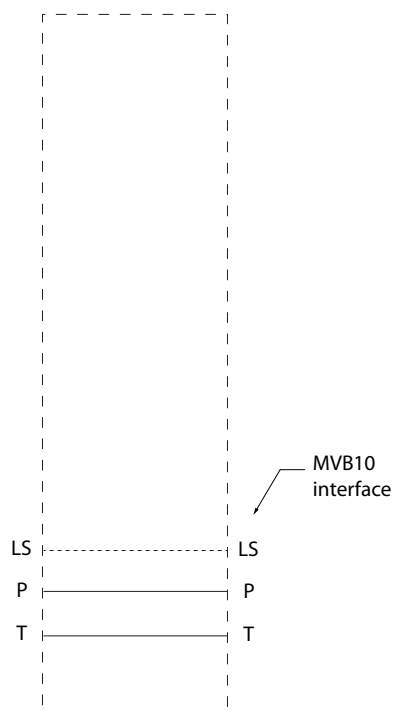

Technical Information
MVB10 Module Valve Block

Inlet module

MVB10-I dimension drawing

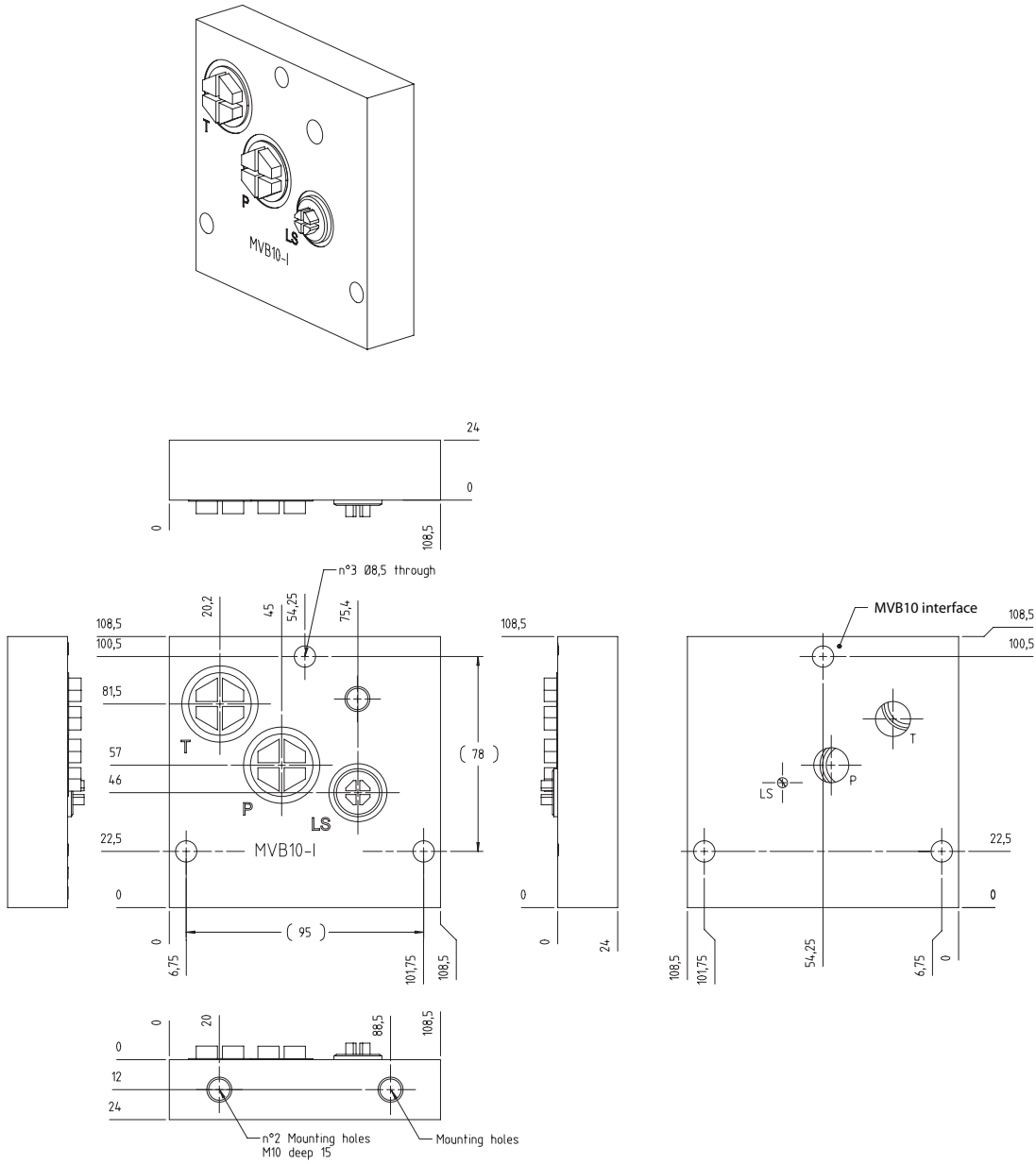

Inlet module

Inlet module component selection

The options for the inlet module area standard version equipped only with ports or an LS version equipped with cartridge valves.

For the valve selection:

- The relief valve (RV) will limit system pressure through regulating the pressure in the LS passage. If the LS pressure is controlled by an external component, this can be replaced with a plug
- The logic element (LE) will bypass excess flow to tank when applied with a fixed pump. LE can be replaced with a plug when applied with a variable displacement pump. In this case we recommend an external relief valve to protect the circuit
- The enable valve (SV) will allow flow to be bypassed at low pressure when de-energized through connecting the LS signal to tank. It will also disable the system in the case of power loss

Inlet module component selection

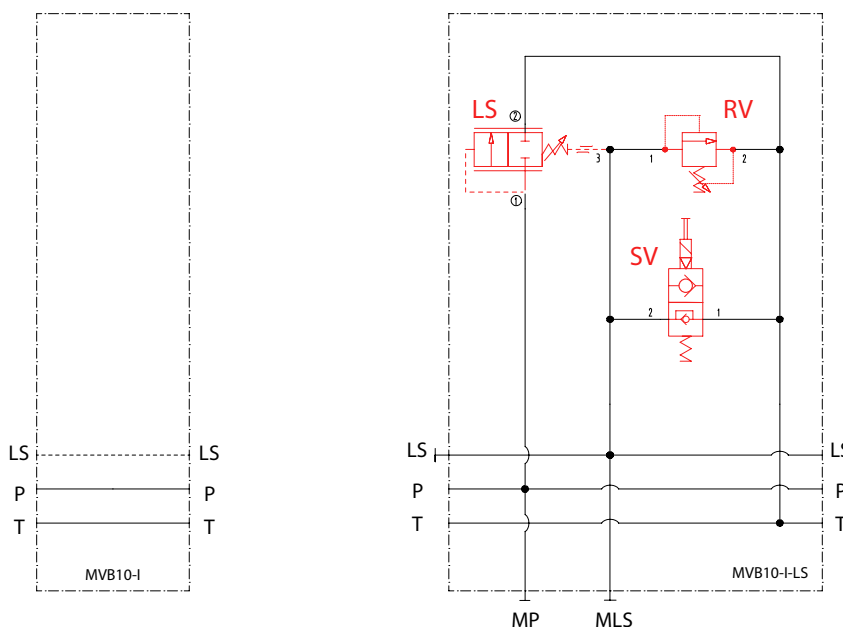

Cartridges shown in red are not included as a part of the base module and must be purchased separately. Refer to *Inlet module component selection* on page 11 for available options.

Inlet module component selection

Model code	Description	Part number
Body Type		
MVB10-I-4B	Standard Inlet Section. P and T: 1/2 BSP. LS: 1/4 BSP	11193649
MVB10-I-10S	Standard Inlet Section. P and T: #10 SAE. LS: #6 SAE	11198412
MVB10-I-LS-4B	Inlet section with compensation: relief and shut off options. P and T: 1/2 BSP ports. LS, MLS, MP: 1/4 BSP	11189404
MVB10-I-LS-10S	Inlet section with compensation: relief and shut off options. P and T: #10 SAE. LS, MLS, MP: #6 SAE	11195194
SV - Solenoid Valve (for additional options, see M13 & R13 coil catalog pages)		
CP08-B-2-B	No solenoid valve - Plug - Buna seals	920554
SVP08-NO-00-00-B-00	Solenoid valve - push pin override - no screen - Buna seals	805315219
SV - Solenoid Valve Coil (for additional options, see SVP08-NO technical information)		
M13-24D-20W-DN	Standard Coil: DIN 43650 connector, 24V	171139819

Inlet module

Inlet module component selection (continued)

Model code	Description	Part number
M13-12D-20W-DN	Standard Coil: DIN 43650 connector, 12V	171140019
M13-24D-20W-DE	Standard Coil: Deutsch DT04-2P connector, 24V	17114131
M13-12D-20W-DE	Standard Coil: Deutsch DT04-2P connector, 12V	17114141
R13-24D-16W-DE	Robust Coil: Deutsch DT04-2P connector, 24V	171180419
R13-12D-16W-DE	Robust Coil: Deutsch DT04-2P connector, 12V	171180619
RV - Relief Valve (for additional options, see RV08-DR catalog page)		
CP08-B-2-B	No Relief valve - Plug - Buna seals	920554
RV08-DR-2-E-100-B-00	Relief valve: external screw adjustment, Buna seals, 100 bar setting	810216519
RV08-DR-2-E-110-B-00	Relief valve: external screw adjustment, Buna seals, 110 bar setting	83054656
RV08-DR-2-E-120-B-00	Relief valve: external screw adjustment, Buna seals, 120 bar setting	83014557
RV08-DR-3-E-130-B-00	Relief valve: external screw adjustment, Buna seals, 130 bar setting	83051234
RV08-DR-3-E-140-B-00	Relief valve: external screw adjustment, Buna seals, 140 bar setting	83016195
RV08-DR-3-E-150-B-00	Relief valve: external screw adjustment, Buna seals, 150 bar setting	83006885
RV08-DR-3-E-160-B-00	Relief valve: external screw adjustment, Buna seals, 160 bar setting	83022156
RV08-DR-3-E-170-B-00	Relief valve: external screw adjustment, Buna seals, 170 bar setting	83024408
RV08-DR-3-E-180-B-00	Relief valve: external screw adjustment, Buna seals, 180 bar setting	83024684
RV08-DR-3-E-190-B-00	Relief valve: external screw adjustment, Buna seals, 190 bar setting	83006694
RV08-DR-3-E-200-B-00	Relief valve: external screw adjustment, Buna seals, 200 bar setting	810217319
RV08-DR-3-E-210-B-00	Relief valve: external screw adjustment, Buna seals, 210 bar setting	83018587
LS - Compensator (for additional options, see HLE10-CPC and HLEA10-CPC catalog pages)		
CP10-B-3S-B	No compensator - plug - Buna seals	11018366
HLE10-CPC-15-B-00	Compensator - 15 bar bias spring - Buna seals	83038529
HLEA10-CPC-E-15-B-00	Adjustable compensator - 15 bar setting - Buna seals	83033826

Interface module

MVB10-IF

Operation



This connection interface does not include any active components and may be used to connect MVB10 modules with PVG32/16 modules. The unique synergy between the MVB10 and the Danfoss PVG product line allows the use of the same tie-rods kits across both product groups. This enables assemblies the flexibility to be expanded across both product lines to meet the configuration requirements.

Before combining MVB10 sections with products from the Danfoss PVG product families, carefully read and consider the relevant operating instructions provided by Danfoss. Failure to comply with these instructions may result in performance or safety issues.

Standard inlet module

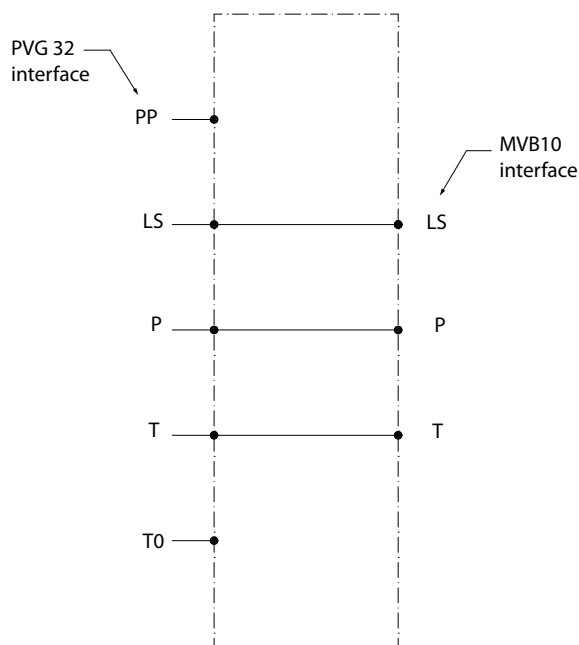

Interface module

MVB10-IF dimension drawing

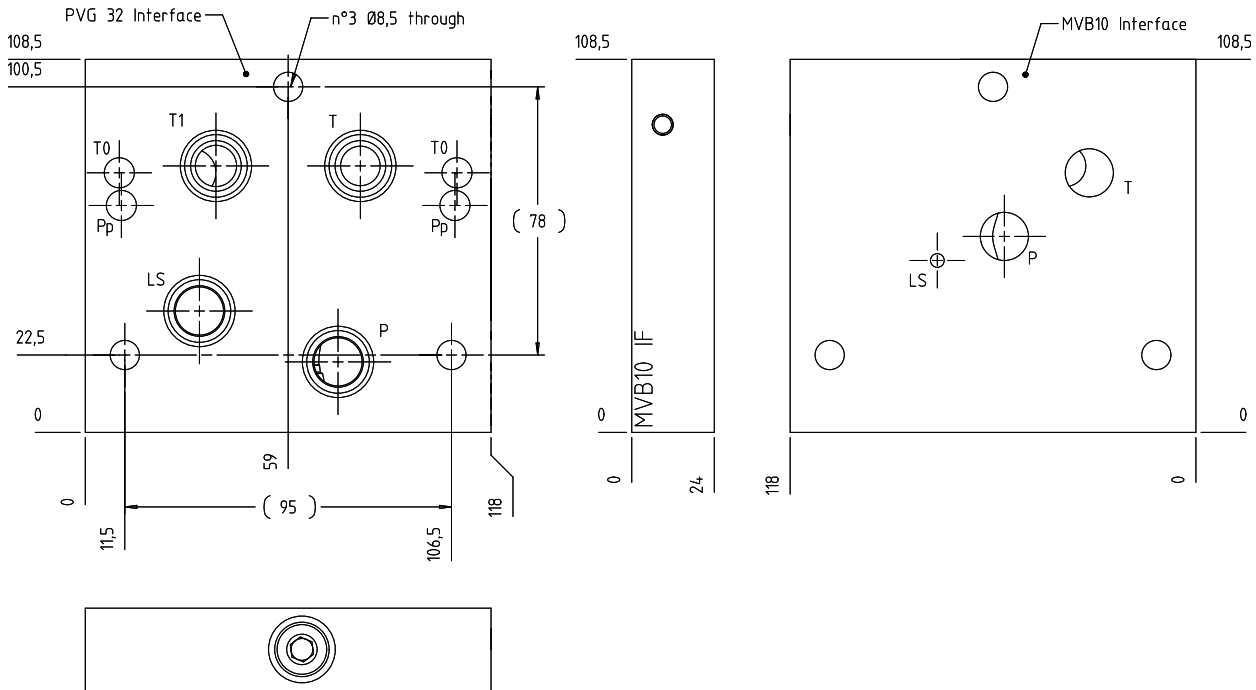

Application awareness

Standard open center PVG inlets use a 10 bar (145 psi) compensating element. When using a compensated MVB10 work section with this inlet, a compensator of 7 bar (100 psi) or less is recommended.

The PVG and the MVB10 will share a common inlet when used with the standard interface plate (MVB10-IF). The maximum pressure rating of the entire stack will be 210 bar (3000 psi).

When a non-compensated work section is applied with a high inlet pressure and low load pressure, the high pressure differential can cause the flow rate to exceed catalog rating of the solenoid. The operating envelope of the solenoid valve should be followed to ensure proper shifting. Careful evaluation should be given to applications using pressure compensated pumps as well as those requiring simultaneous use of multiple functions with differing loads. In these types of applications where there is a risk of overflowing the solenoid, a compensated or flow control work section can be used.

Interface module component selection

Model code	Description	Part number
MVB10-IF	PVG Interface Plate	11187916

Working module

MVB10-W

Operation

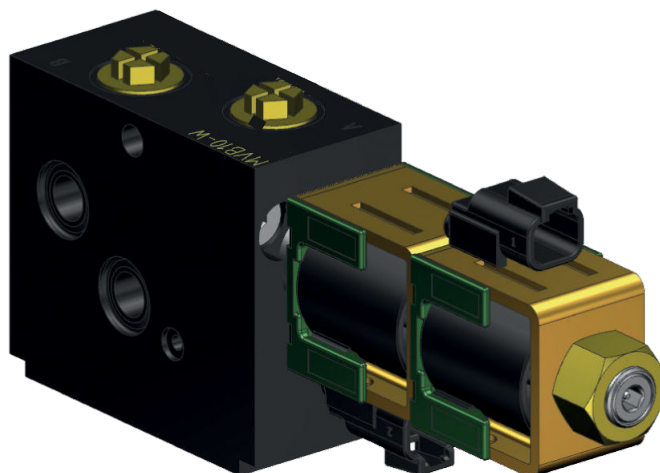

This work section provides on-off directional control of a double acting actuator.

This is a non-compensated module. High pressure differentials across this section can cause the flow rate to exceed catalog rating of the solenoid. The operating envelope of the solenoid valve should be followed to ensure proper shifting. For valve operating limits, review the solenoid valve catalog page. For additional information, see the application note in the Component Selection section of this catalog.

Non-compensated working module

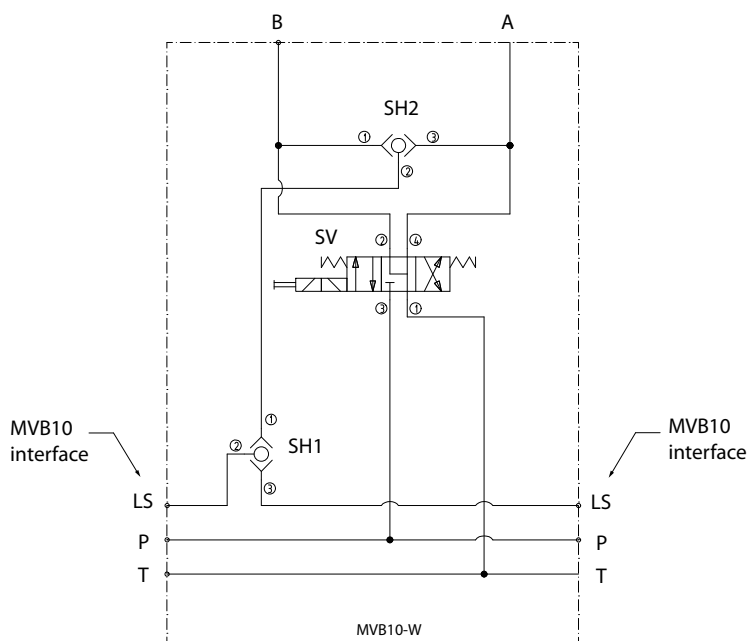

Working module

MVB10-W dimension drawing

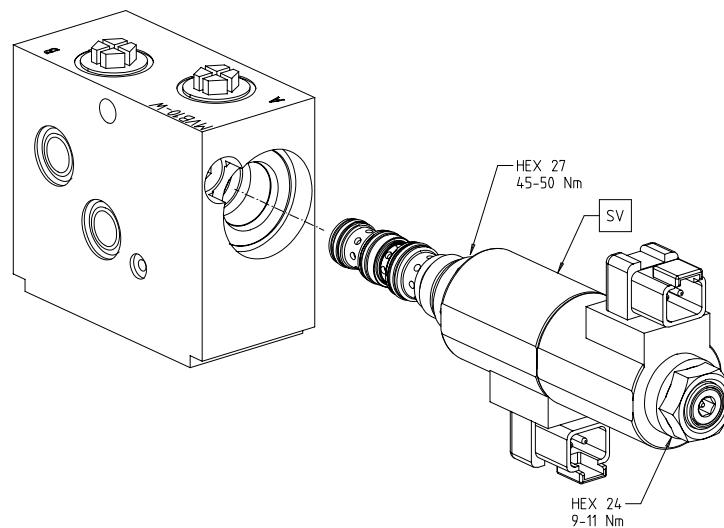
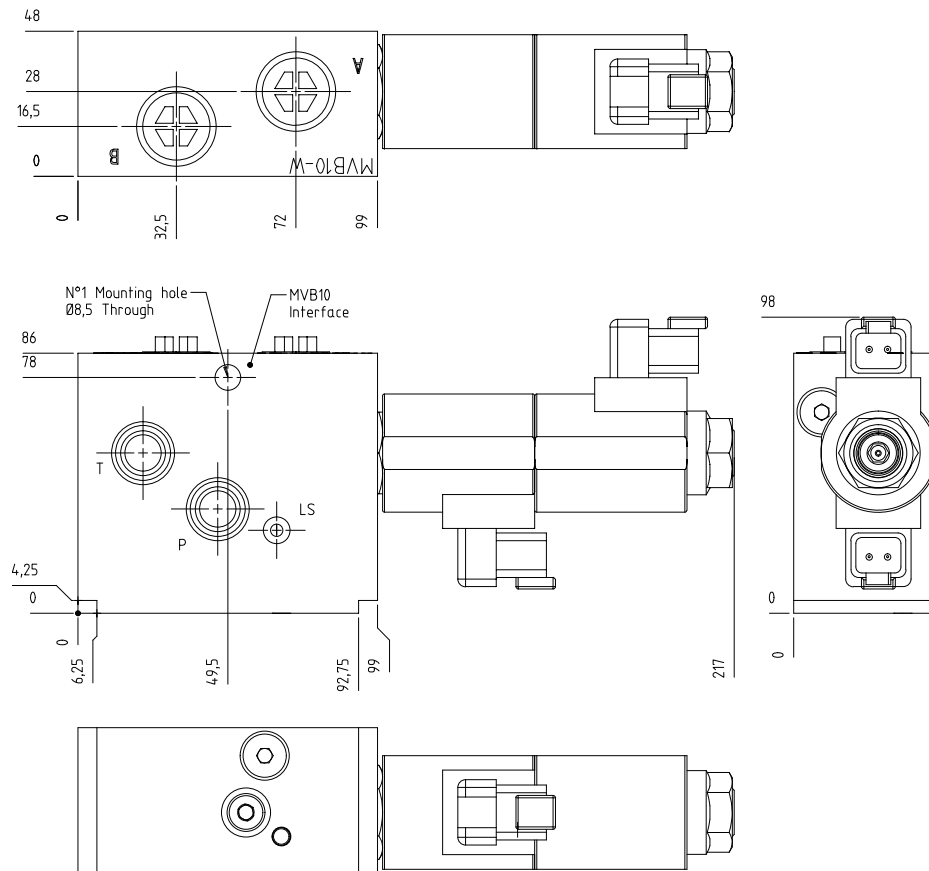

Working module

MVB10-W-C

Operation

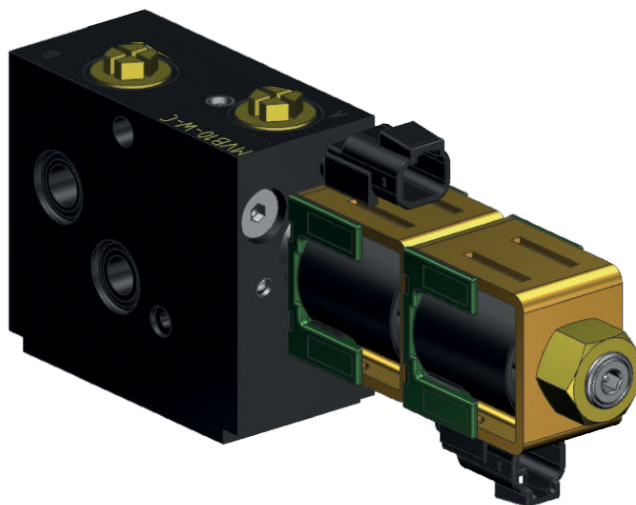

This pressure compensated work section provides proportional load-independent directional control of a double acting actuator.

Compensated working module

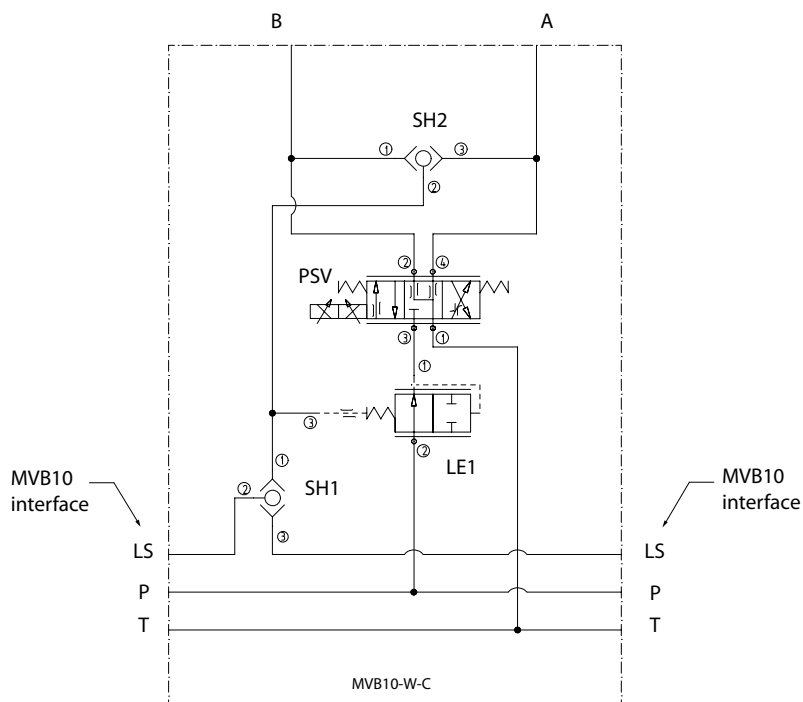

Working module

MVB10-W-C dimension drawing

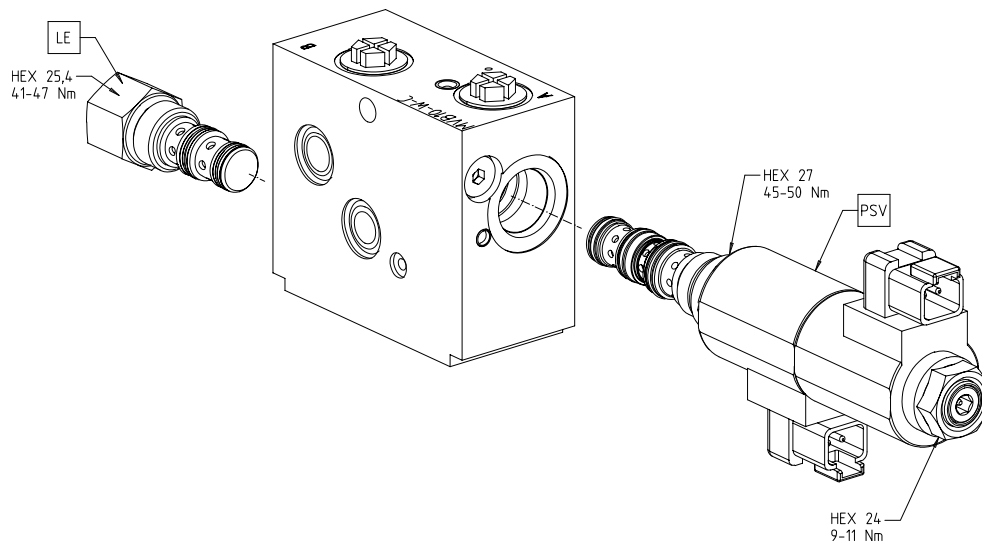
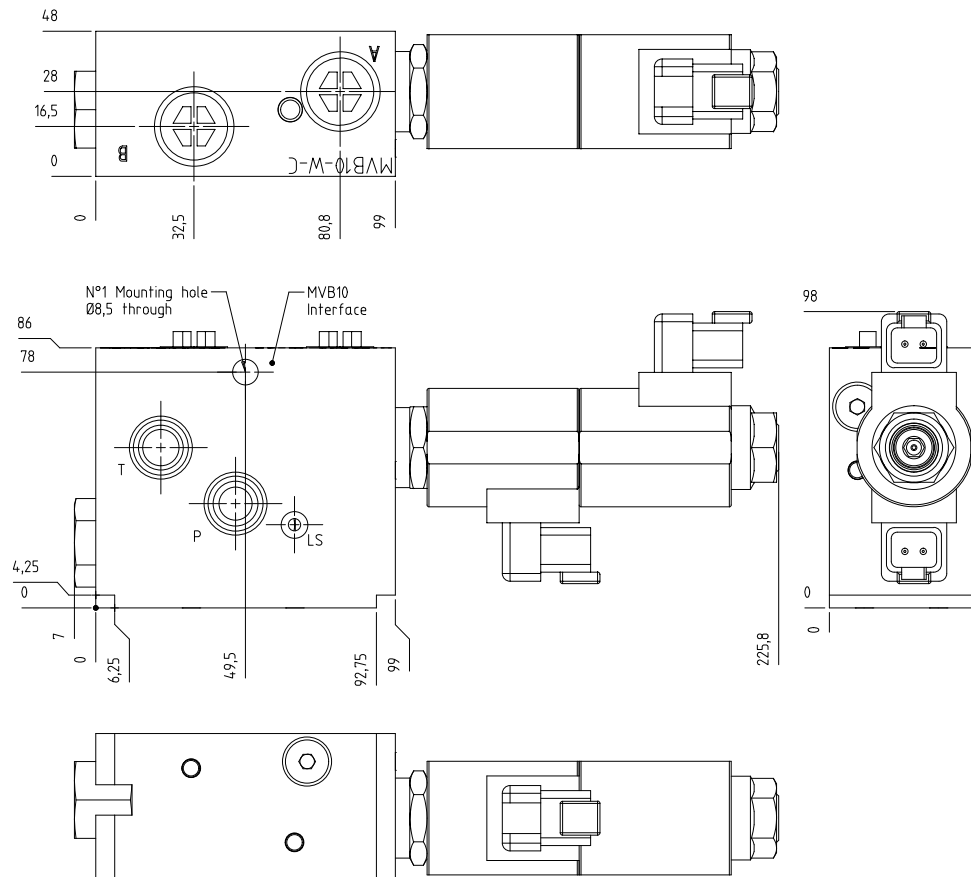

Working module

MVB10-W-LH with counterbalance valves

Operation

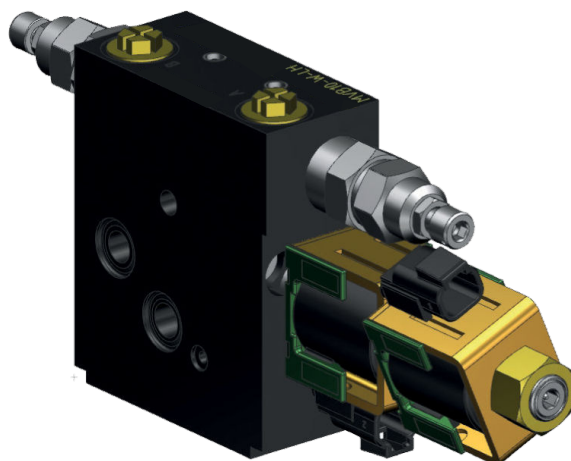

This work section provides on-off directional control of a double acting actuator. A load holding cartridge keeps an actuator in position by preventing any leakage that may cause drifting.

Counter balance valves help control the movement of lowering or runaway loads by restricting the flow returning to tank from the actuator. They also provide an antishock function by limiting the maximum pressure inside the actuator.

To ensure proper operation, this load holding module should always be specified with a directional control valve which connects the work ports to tank in the neutral position.

This is a non-compensated module. High pressure differentials across this section can cause the flow rate to exceed catalog rating of the solenoid. The operating envelope of the solenoid valve should be followed to ensure proper shifting. For valve operating limits, review the solenoid valve catalog page. For additional information, see the application note in the Component Selection section of this catalog.

Load holding with counterbalance

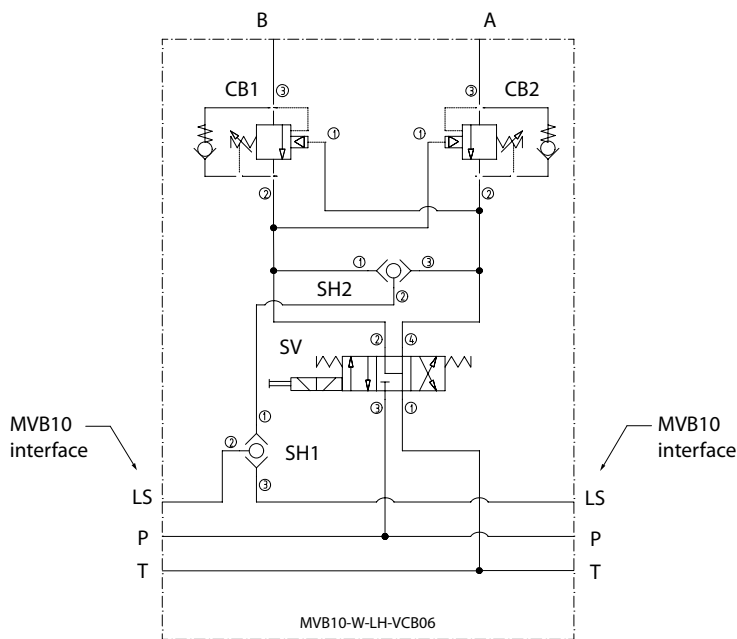

Working module

MVB10-W-LH with counterbalance valves dimension drawing

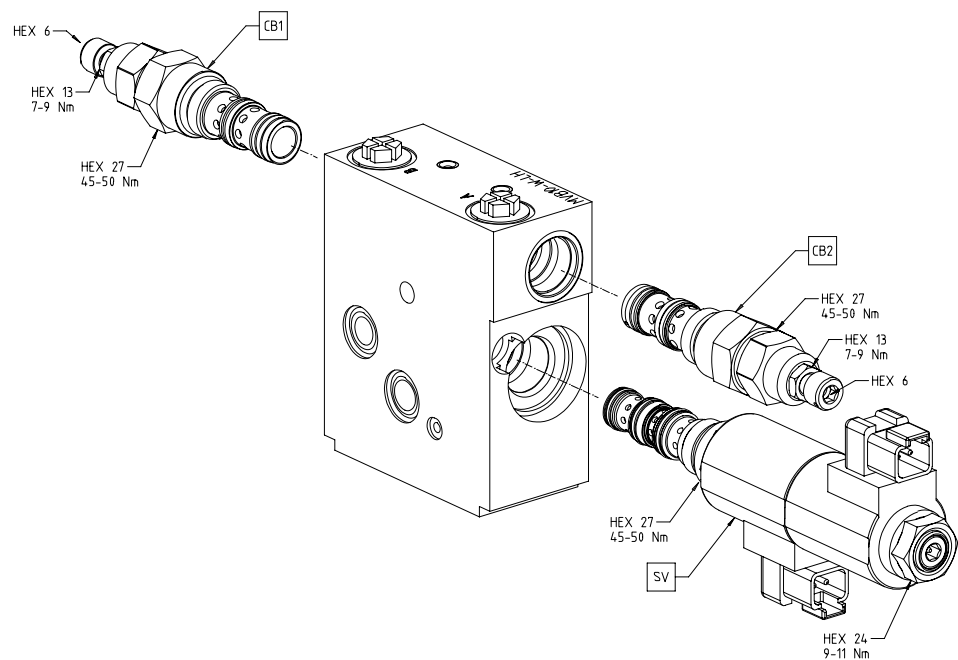
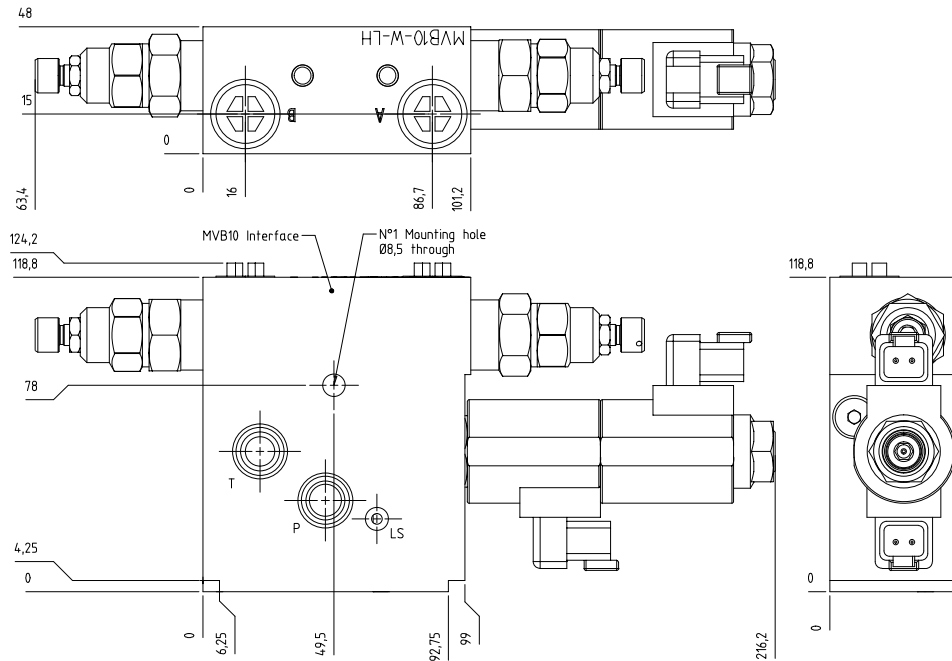

Working module

MVB10-W-LH with pilot check valves

Operation

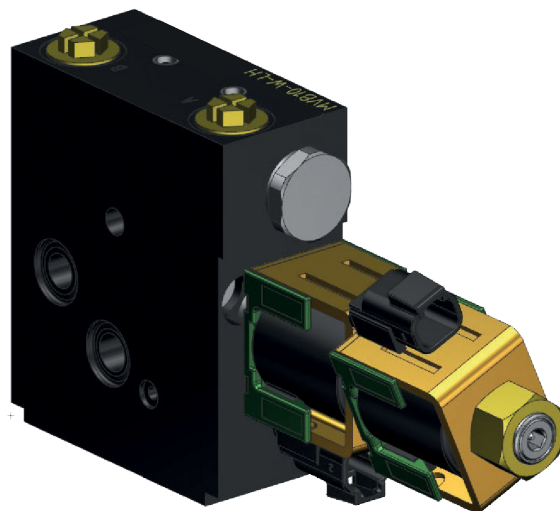

This work section provides on-off directional control of a double acting actuator. A load holding cartridge keeps an actuator in position by preventing any leakage that may cause drifting.

Pilot operated check valves minimize the restriction of flow to and from the actuator and therefore help achieve the best energy efficiency in simple load control situations.

To ensure proper operation, this load holding module should always be specified with a directional control valve which connects the work ports to tank in the neutral position.

This is a non-compensated module. High pressure differentials across this section can cause the flow rate to exceed catalog rating of the solenoid. The operating envelope of the solenoid valve should be followed to ensure proper shifting. For valve operating limits, review the solenoid valve catalog page. For additional information, see the application note in the Component Selection section of this catalog.

Working module

Load holding with pilot check valves

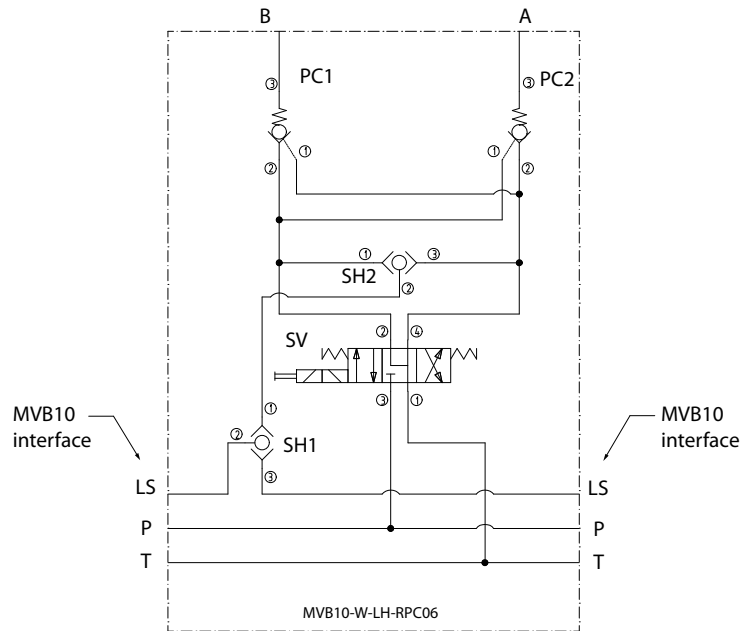

Working module

MVB10-W-LH with pilot check valves dimension drawing

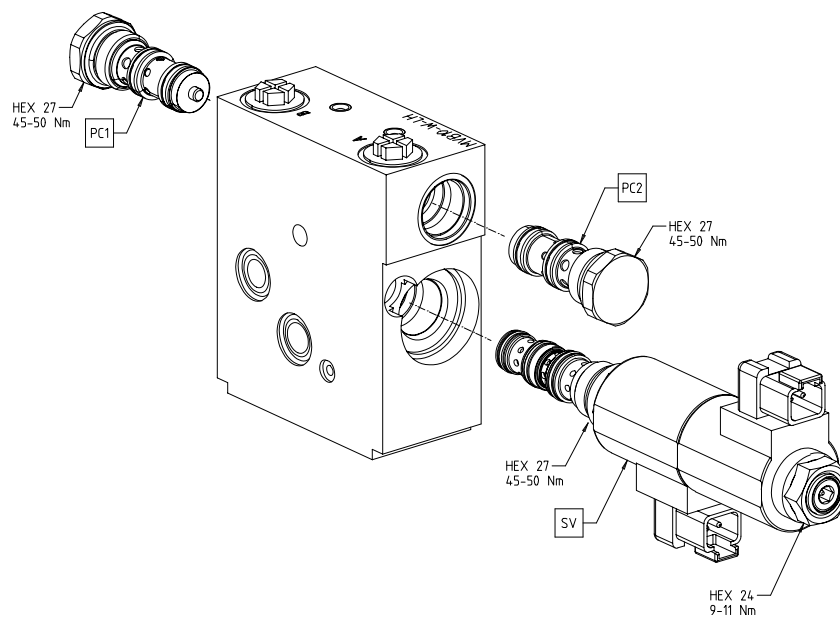
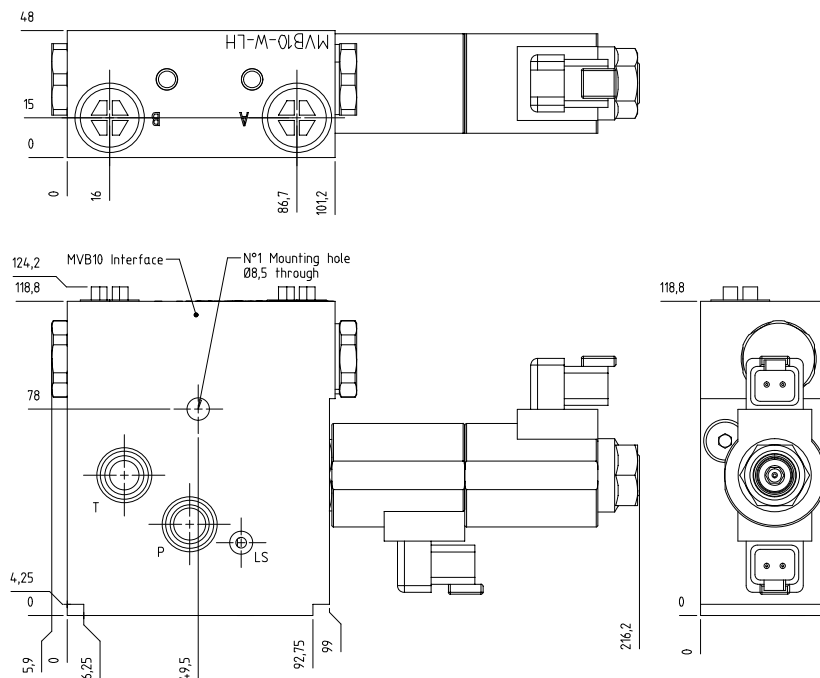

Working module

MVB10-W-C-LH with counterbalance valves

Operation

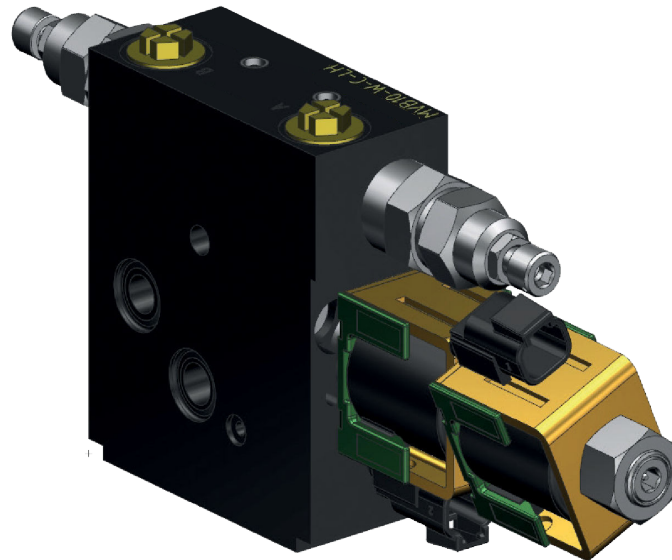

This pressure compensated work section provides proportional load-independent directional control of a double acting actuator. A load holding device keeps an actuator in position by preventing any leakage that may cause drifting.

Counterbalance valves help control the movement of lowering or run-away loads by restricting the flow returning to tank from the actuator. They also provide an antishock function by limiting the maximum pressure inside the actuator.

To ensure proper operation, this load holding module should always be specified with a directional control valve which connects the work ports to tank in the neutral position.

Working module

Compensated working module load holding with pilot check valve

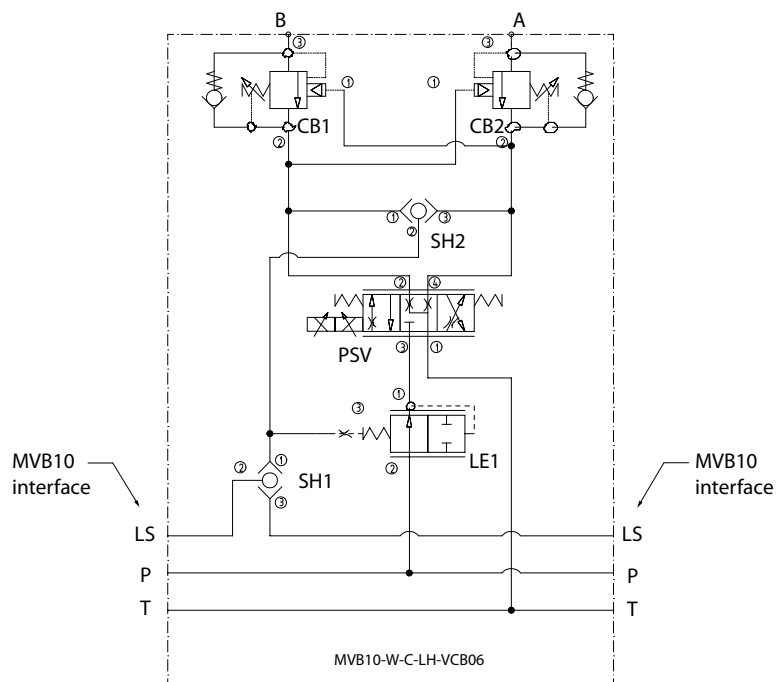

Working module

MVB10-W-C-LH with counterbalance valve dimension drawing

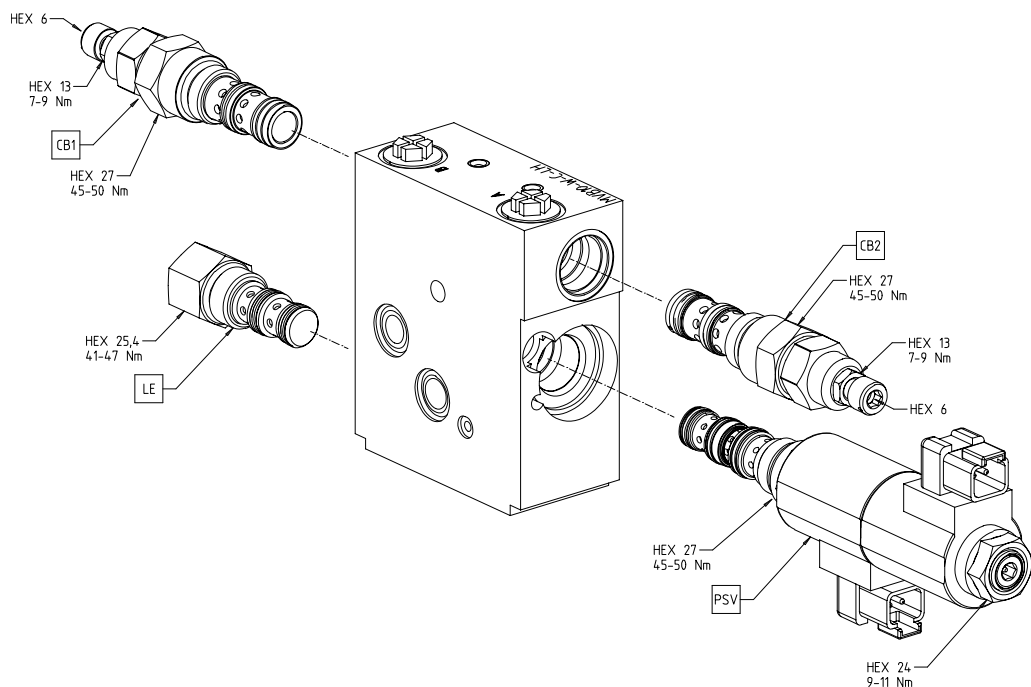
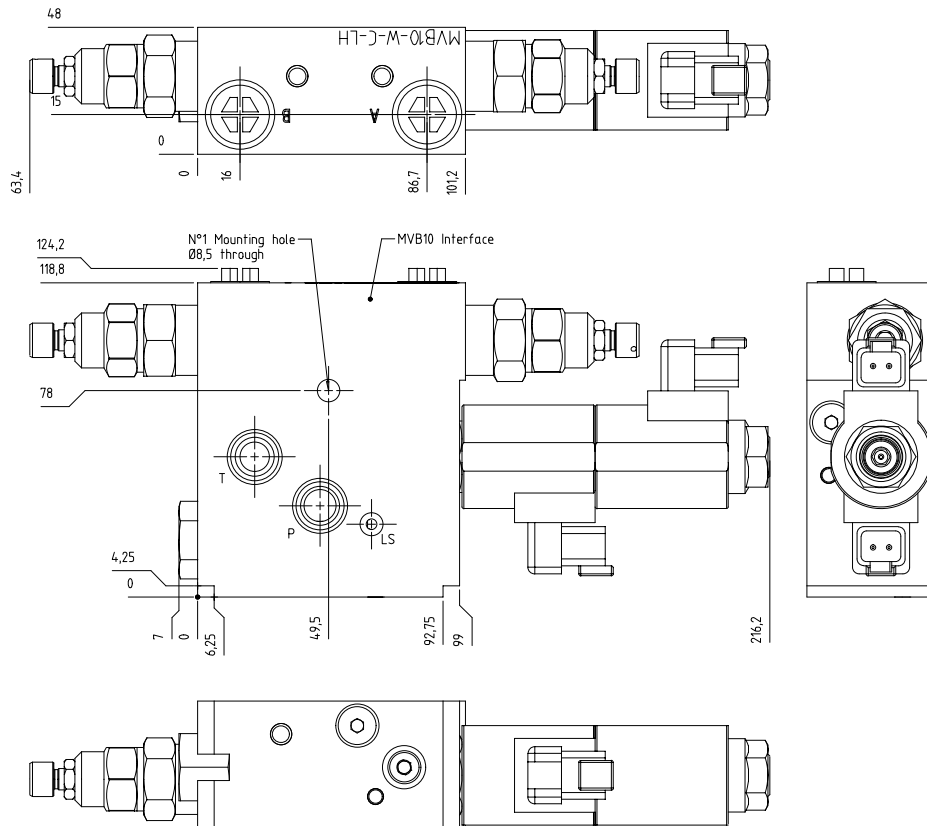

Working module

MVB10-W-C-LH with pilot check valves

Operation

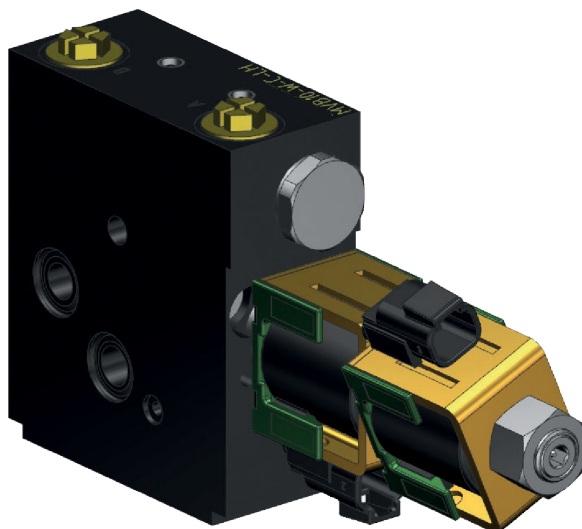

This pressure compensated work section provides proportional load-independent directional control of a double acting actuator. A load holding device keeps an actuator in position by preventing any leakage that may cause drifting.

Pilot operated check valves minimize the restriction of flow to and from the actuator and therefore help achieve the best energy efficiency in simple load control situations.

To ensure proper operation, this load holding module should always be specified with a directional control valve which connects the work ports to tank in the neutral position.

Compensated working module

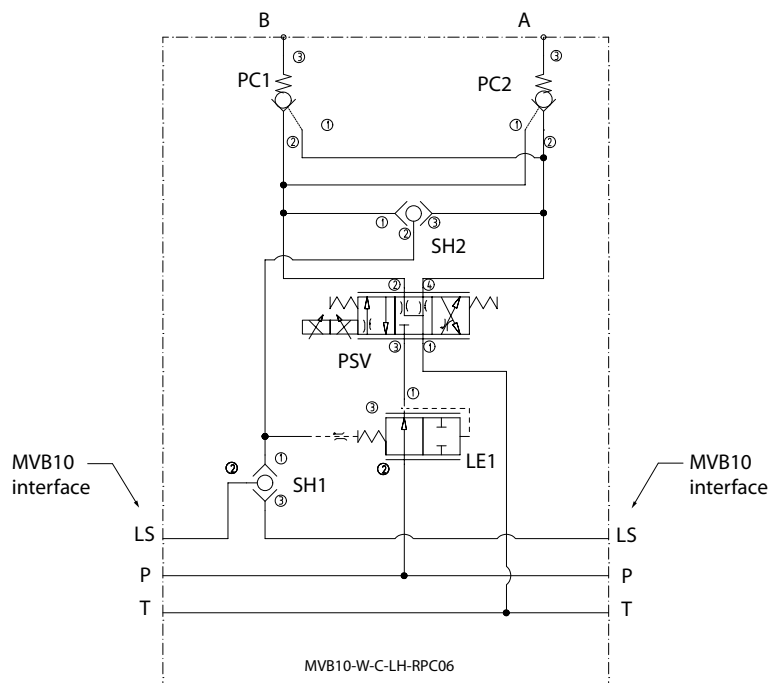

Working module

MVB10-W-C-LH with pilot check valves dimension drawing

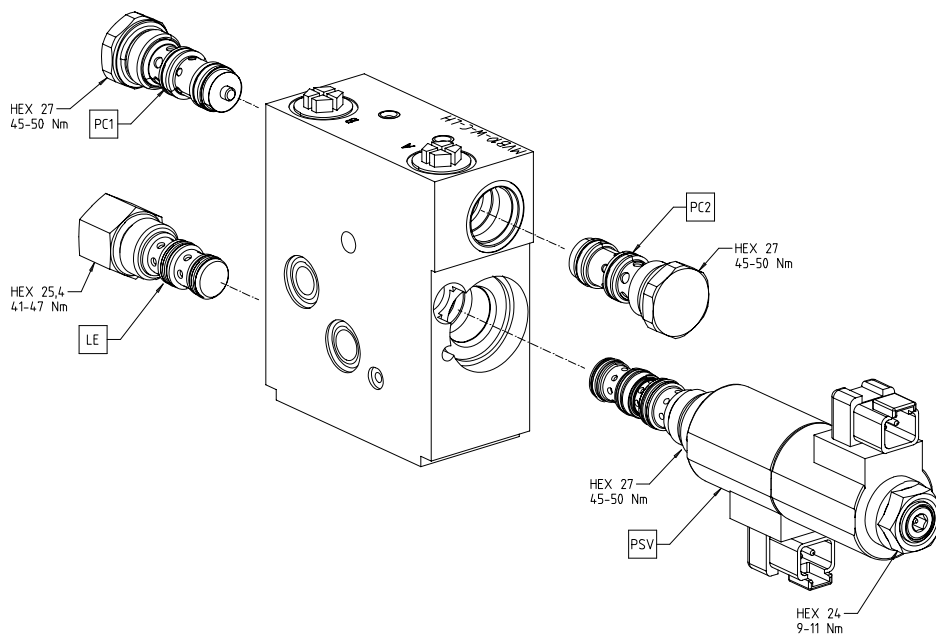
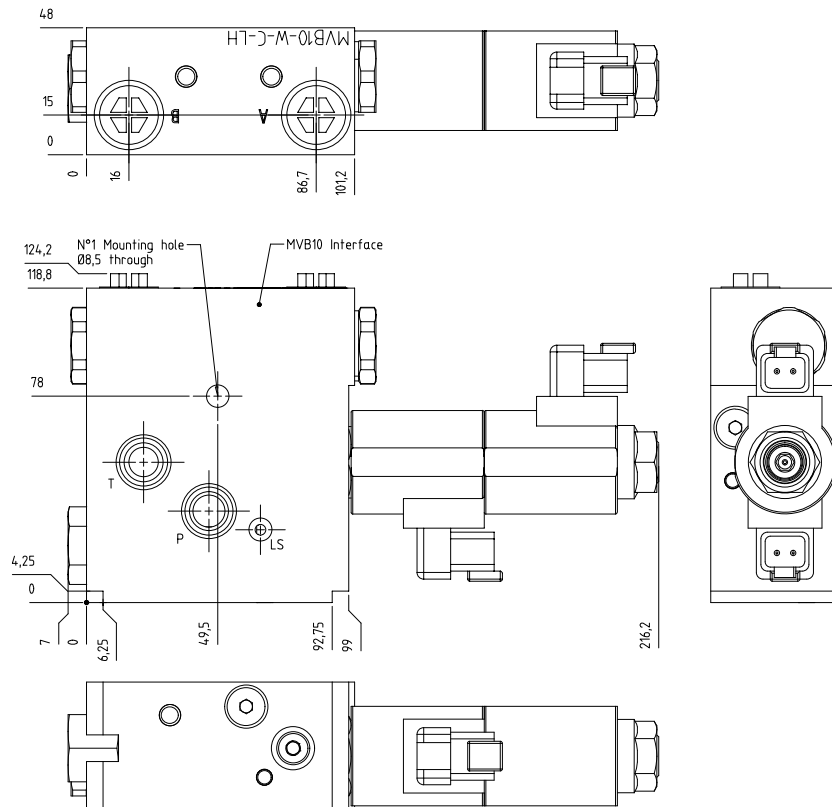

Working module

MVB10-W-F

Operation

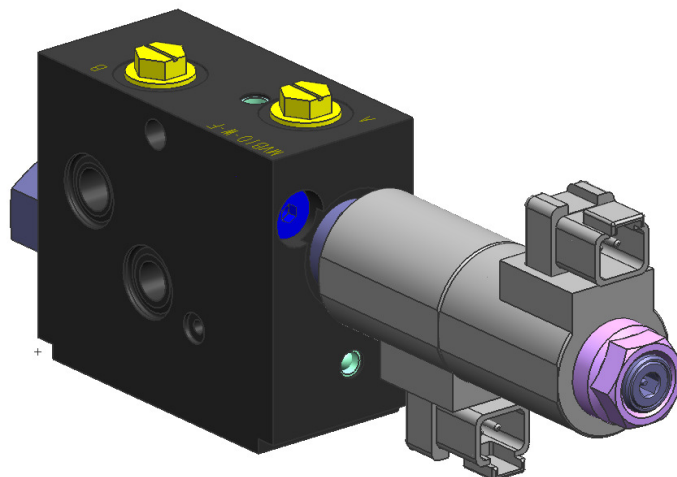

This work section provides on-off directional control of a double acting actuator. The flow control before the directional valve will limit the flow through the section to the actuator. An SDC10-2 cavity is provided for the flow control valve, allowing the use of a pressure compensated flow control or non-compensated, adjustable needle valve.

High pressure differentials across this section can cause the flow rate to exceed catalog rating of the solenoid when used with non-compensated flow controls. The operating envelope of the solenoid valve should be followed to ensure proper shifting. For valve operating limits, review the solenoid valve catalog page. For additional information, see the application note in [Working module component selection](#) on page 37.

Flow control working module

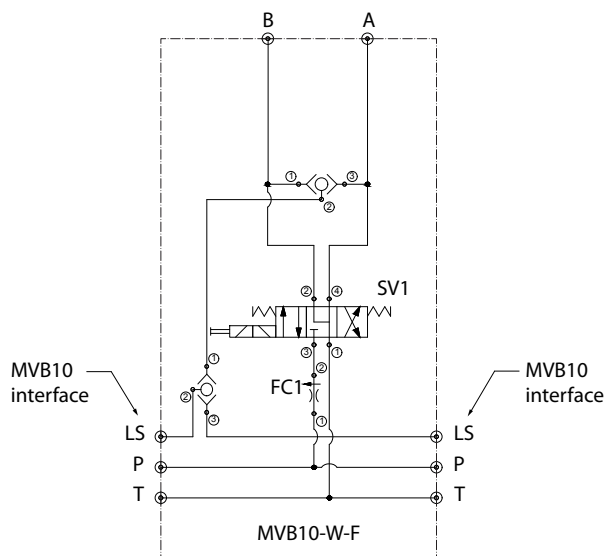

Working module

MVB10-W-F dimension drawing

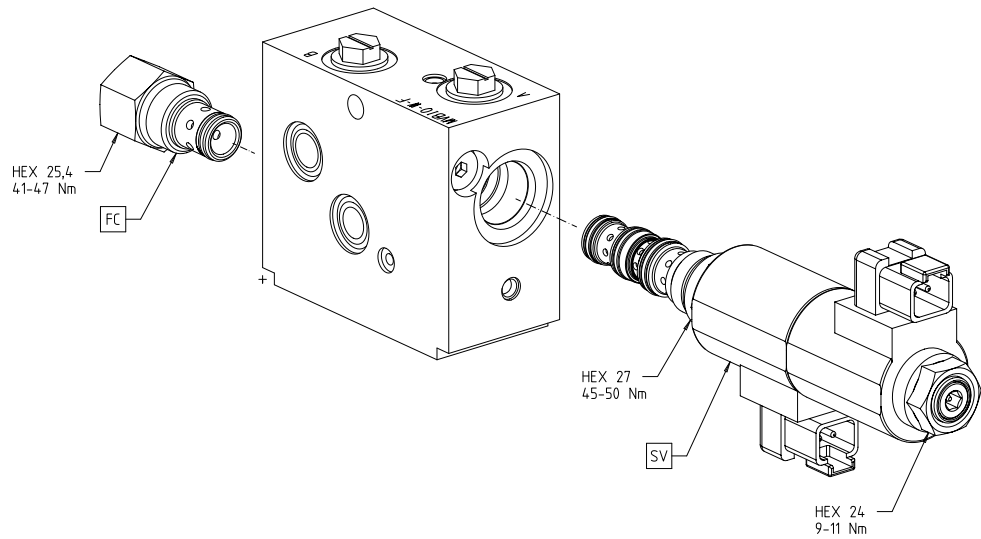
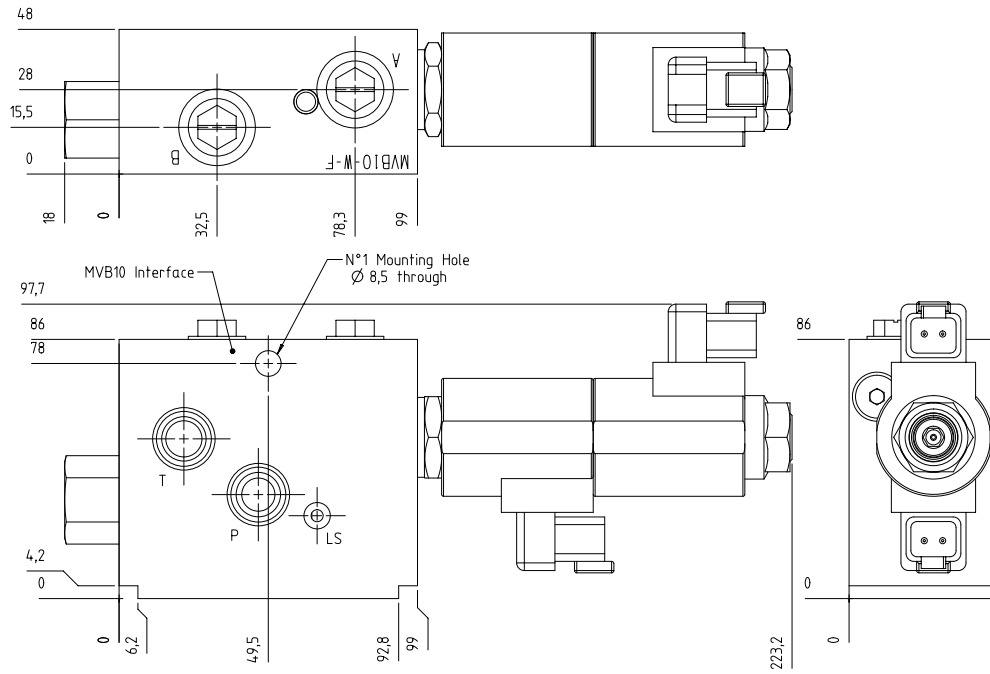

Working module

MVB10-W-F-LH with counterbalance valves

Operation

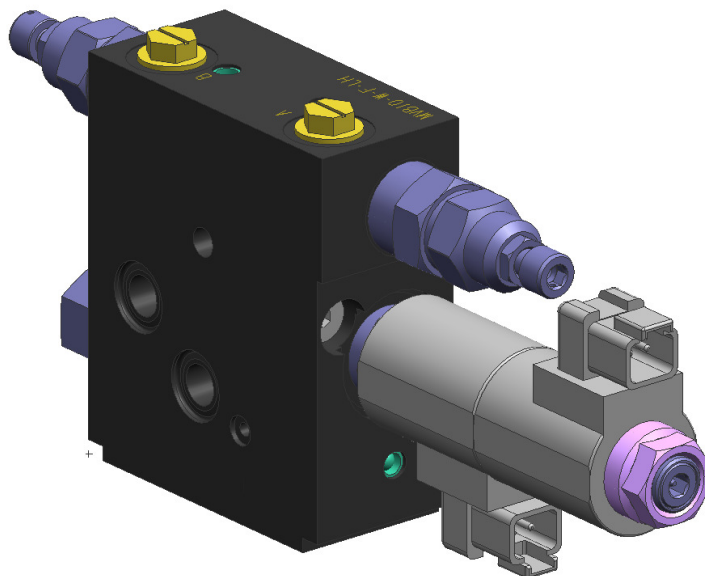

This work section provides on-off directional control of a double acting actuator. The flow control before the directional valve will limit the flow through the section to the actuator. An SDC10-2 cavity is provided for the flow control valve, allowing the use of a pressure compensated flow control or non-compensated, adjustable needle valve. A load holding cartridge keeps an actuator in position by preventing any leakage that may cause drifting.

Counter balance valves help control the movement of lowering or runaway loads by restricting the flow returning to tank from the actuator. They also provide an antishock function by limiting the maximum pressure inside the actuator.

To ensure proper operation, this load holding module should always be specified with a directional control valve which connects the work ports to tank in the neutral position.

High pressure differentials across this section can cause the flow rate to exceed catalog rating of the solenoid when used with non-compensated flow controls. The operating envelope of the solenoid valve should be followed to ensure proper shifting. For valve operating limits, review the solenoid valve catalog page. For additional information, see the application note in [Working module component selection](#) on page 37.

Working module

Flow control and load holding with counterbalance

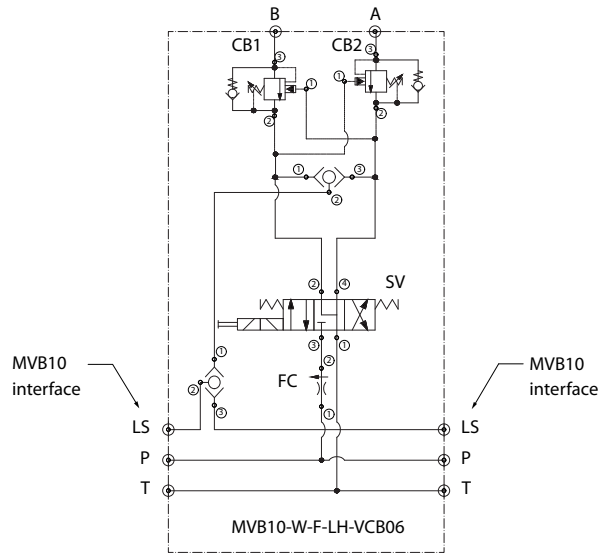

Working module

MVB10-W-F-LH with counterbalance valve dimension drawing

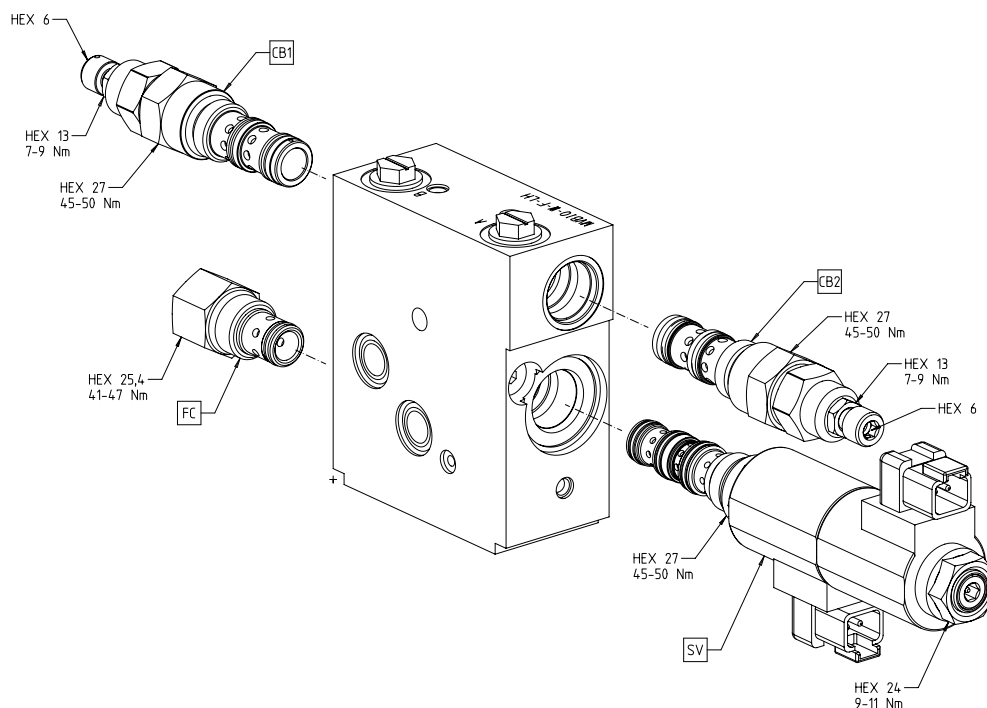
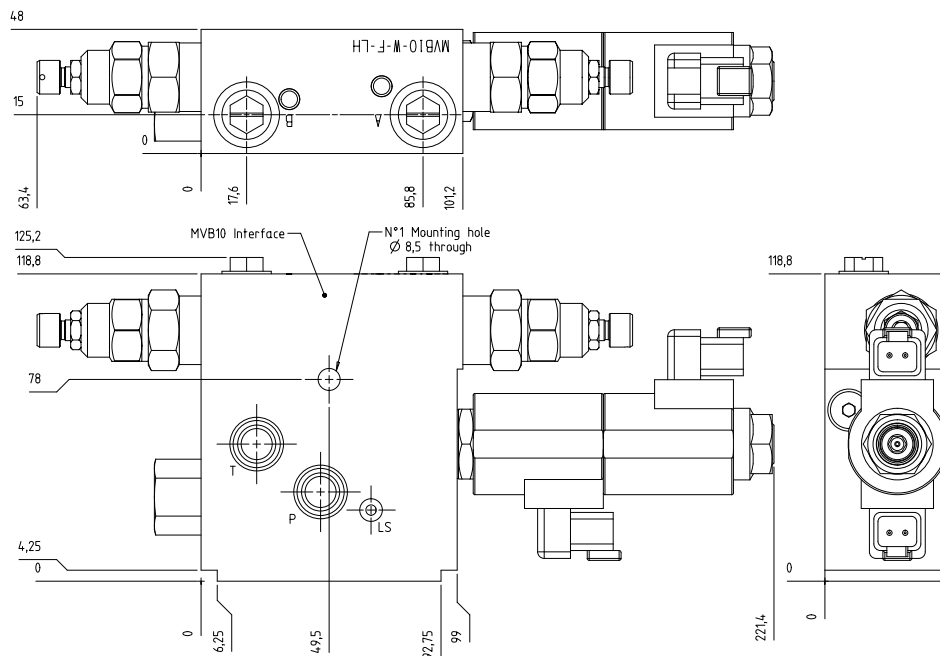

Working module

MVB10-W-F-LH with pilot check valves

Operation

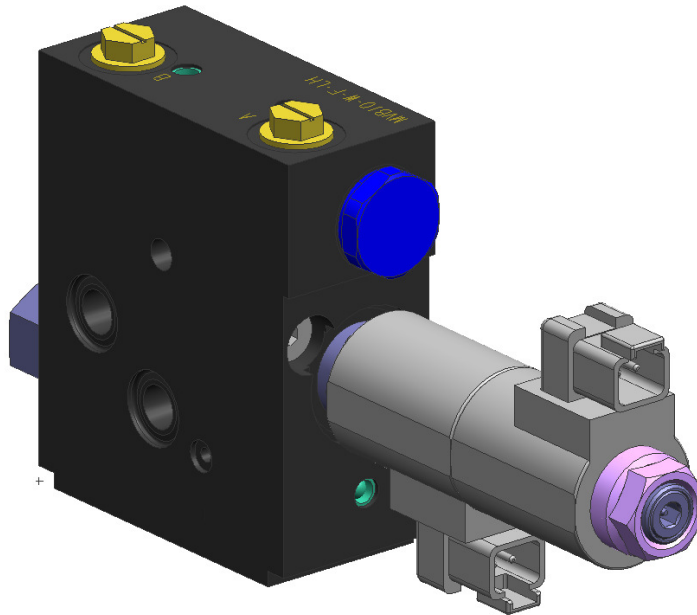

This work section provides on-off directional control of a double acting actuator. The flow control before the directional valve will limit the flow through the section to the actuator. An SDC10-2 cavity is provided for the flow control valve, allowing the use of a pressure compensated flow control or non-compensated, adjustable needle valve. A load holding cartridge keeps an actuator in position by preventing any leakage that may cause drifting.

Pilot operated check valves minimize the restriction of flow to and from the actuator and therefore help achieve the best energy efficiency in simple load control situations.

To ensure proper operation, this load holding module should always be specified with a directional control valve which connects the work ports to tank in the neutral position.

High pressure differentials across this section can cause the flow rate to exceed catalog rating of the solenoid when used with non-compensated flow controls. The operating envelope of the solenoid valve should be followed to ensure proper shifting. For valve operating limits, review the solenoid valve catalog page. For additional information, see the application note in [Working module component selection](#) on page 37.

Working module

Flow control and load handling with pilot check valves

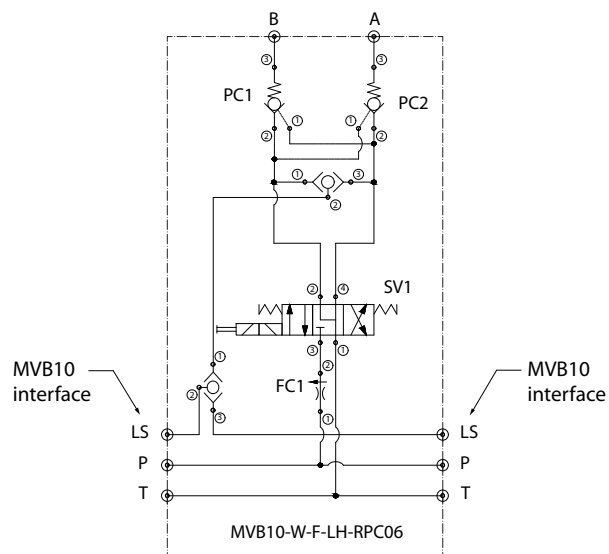

Working module

MVB10-W-F-LH with pilot check valves dimension drawing

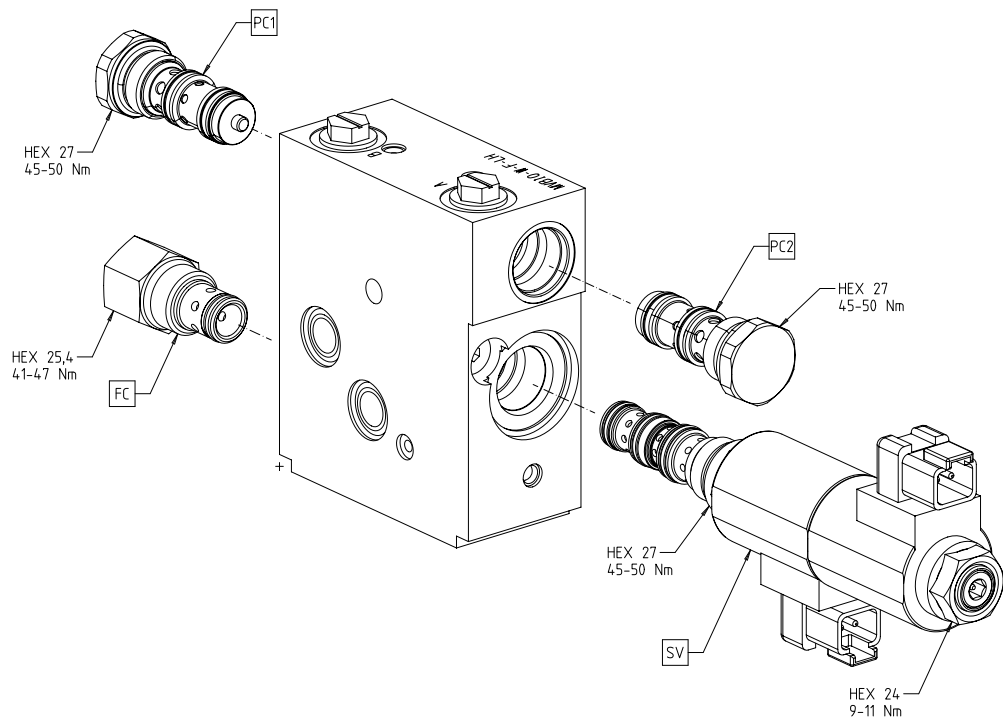
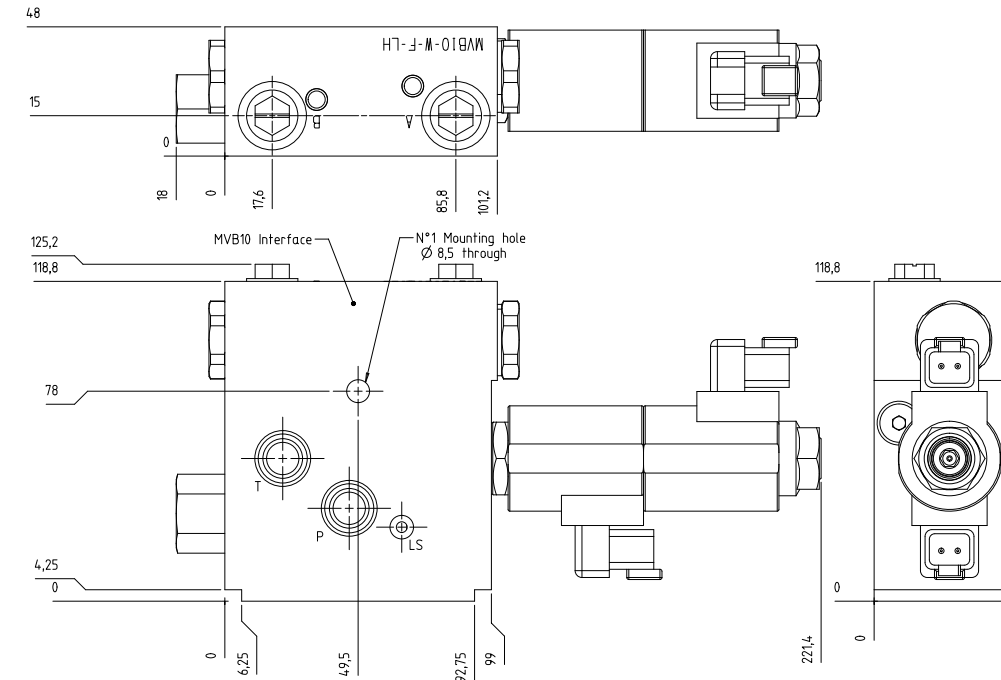

Working module

Working module component selection

The working modules can have on/off or proportional compensated directional control, with or without load holding.

The design of a new valve stack begins with the selection of the empty module, according to the required function.

The load sense shuttle valves are included in all base modules and do not need to be specified separately. It is possible to select the required components that can be specified in the module.

All of the solenoid and proportionals valves in the table can fit in all modules.

All of the logic elements in the table are compatible with all pressure compensated modules (-C).

All of the load holding valves in the table, both pilot operated check or counterbalance valves, are compatible with all load holding modules(-LH).

When a non-compensated work section is applied with a high inlet pressure and low load pressure, the high pressure differential can cause the flow rate to exceed catalog rating of the solenoid.

The operating envelope of the solenoid valve should be followed to ensure proper shifting. Careful evaluation should be given to applications using pressure compensated pumps and those requiring simultaneous use of multiple functions with differing loads. In these types of applications where there is a risk of overflowing the solenoid, a compensated or flow control work section can be used.

Working module

Working module component selection

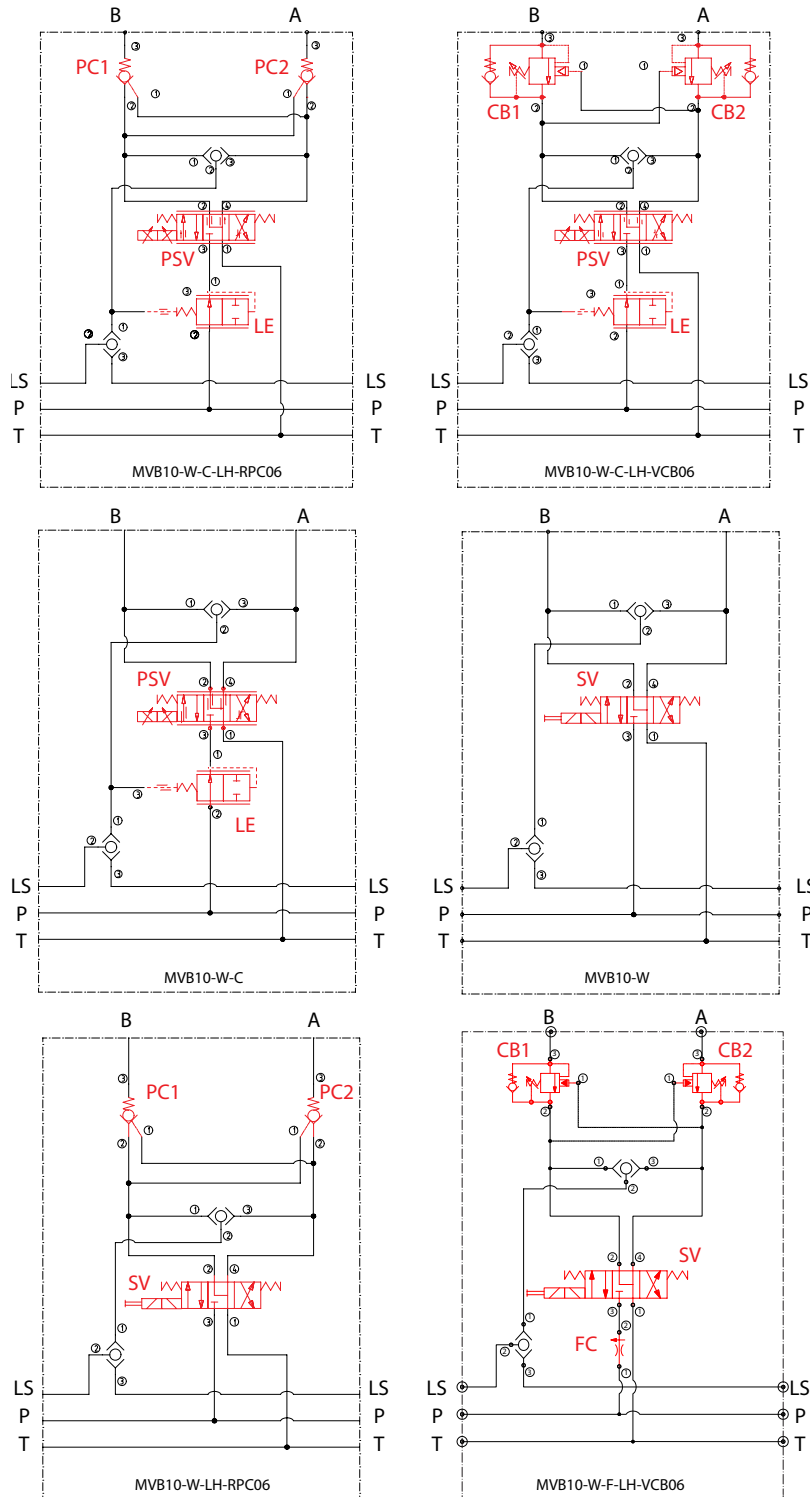

Cartridges shown in red are not included as a part of the base module and must be purchased separately. Refer to *Working module component selection* on page 39 for available options.

Working module

Working module component selection

Model code	Description	Part number
Body Type		
MVB10-W-3B	Working module, non compensated, A and B ports G3/8 BSP	11187533
MVB10-W-6S	Working module, non compensated, A and B ports SAE#6	11195179
MVB10-W-C-3B	Working module, compensated, A and B ports G3/8 BSP	11187535
MVB10-W-C-6S	Working module, compensated, A and B ports SAE#6	11195178
MVB10-W-LH-3B	Working module, non compensated, with load holding, A and B ports G3/8 BSP	11188879
MVB10-W-LH-6S	Working module, non compensated, with load holding, A and B ports SAE#6	11195193
MVB10-W-C-LH-3B	Working module, compensated, with load holding, A and B ports G3/8 BSP	11196245
MVB10-W-C-LH-6S	Working module, compensated, with load holding, A and B ports SAE#6	11198419
MVB10-W-F-3B	Working module, flow control, A and B ports G3/8 BSP	11229694
MVB10-W-F-6S	Working module, flow control, A and B ports SAE#6	11202459
MVB10-W-F-LH-3B	Working module, flow control, with load holding, A and B ports G3/8 BSP	11229782
MVB10-W-F-LH-6S	Working module, flow control, with load holding, A and B ports SAE#6	11202460
SV/PSV - Solenoid Valve - (for additional options, see SV10-34-05 and PSV10-34-05 catalog pages)		
SV10-34-05-00-00-B-00	ON-OFF solenoid valve, 4 ways 3 positions, Buna seals	805314819
PSV10-34-05-00-00-22-B-00	Proportional solenoid valve, 4 ways 3 positions, Buna seals	850168919
SV10-34-05-00-00-PAP-00	ON-OFF solenoid valve, 4 ways 3 positions, Buna seals, Push/Pull Override	11181460
PSV10-34-05-00-00-22-B-PAP-00	Proportional solenoid valve, 4 ways 3 positions, Buna seals, Push/Pull Override	11227515
SV/PSV - Solenoid Valve Coil - (for additional options, see M16 and R16 catalog pages)		
M16-12D-26W-DN	Standard coil DIN 43650 connector, 12V	17114581
M16-24D-26W-DN	Standard coil DIN 43650 connector, 24V	171146019
M16-12D-26W-DE	Standard coil Deutsch DT04-2P connector, 12V	17114931
M16-24D-26W-DE	Standard coil Deutsch DT04-2P connector, 24V	171149519
R16-12D-20W-DE	Robust coil Deutsch DT04-2P connector, 12V	171185919
R16-24D-20W-DE	Robust coil Deutsch DT04-2P connector, 24V	171183019
LE - Compensator - (for additional options, see CP700-4 catalog page)		
CP700-4-B-0-150	Compensator - 10,3 bar bias spring - Buna Seals	133899
CP700-4-B-0-100	Compensator - 7,6 bar bias spring - Buna Seals	134241
CP10-B-3-B1	No compensator - Open plug	134493
PC/CB - Load Holding valve - (for additional options, see RPC06 and VCB06-EN catalog pages)		
RPC06/0.5-00	Pilot Check valve - 0,5 bar - Buna Seals	11169090
RPC06/0.5-OR	Pilot Check valve - 0,5 bar - Buna Seals - w/ piston Seal	11169102
RPC06/5-00	Pilot Check valve - 5 bar - Buna Seals	11169108
RPC06/5-OR	Pilot Check valve - 5 bar - Buna Seals - w piston Seal	11169110
VCB06-EN-1-A-00-B		820202619
VCB06-EN-2-A-00-B	Counterbalance valve - range 2 (70-210 bar) - Ratio A (7.1:1) - Buna Seals Counterbalance valve - range 1 (25-140 bar) - Ratio A (7.1:1) - Buna Seals	820202719
VCB06-EN-3-A-00-B	Counterbalance valve - range 3 (105-350 Bar) - Ratio A (7.1:1) - Buna Seals	820202819
VCB06-EN-1-B-00-B	Counterbalance valve - range 1 (25-140 bar) - Ratio B (4.1:1) - Buna Seals	820153929
VCB06-EN-2-B-00-B	Counterbalance valve - range 2 (70-210 bar) - Ratio B (4.1:1) - Buna Seals	820158929
VCB06-EN-3-B-00-B	Counterbalance valve - range 3 (105-350 Bar) - Ratio B (4.1:1) - Buna Seals	820159029
NCS06/0	Cavity Plug NCS06/0	920000619
FC - Flow Control - (for additional options, see CP300-1 and CP610-2 catalog pages)		
CP300-1-B-0-2.4	Flow Control Valve - pressure compensated, 9 lpm - Buna Seals	83055469
CP610-2-B-0-K	Needle Valve - adjustable, knob - Buna Seals	130453

End module

MVB10-E

Operation



This end plate section does not include any active components and may be used for closing a MVB10 assembly.

End plate section

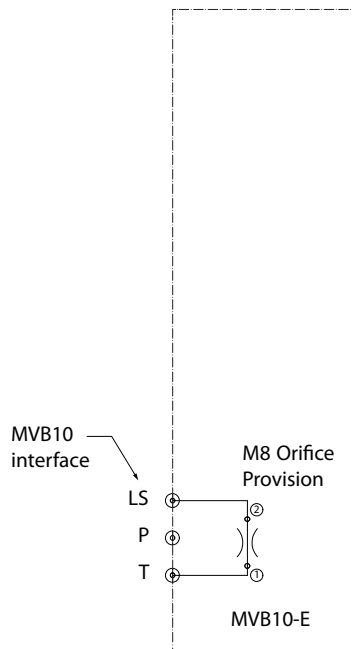

End module

MVB10-E end module dimension drawing

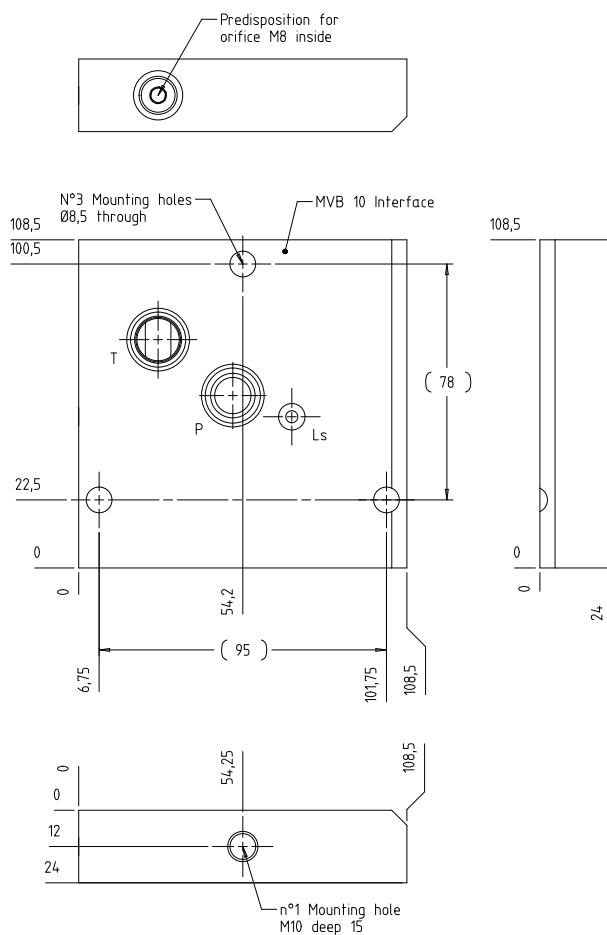

End module component selection

Model code	Description	Part number
MVB10-E	End plate	11187937

Tie rod kits (seals included)

Material number	Order code / Nomenclature
157B8000	PVAS32-MOUNTING KIT-PVG L 054-072MM
157B8031	PVAS32-MOUNTING KIT-PVG L 078-096MM
157B8001	PVAS32-MOUNTING KIT-PVG L 102-120MM
157B8021	PVAS32-MOUNTING KIT-PVG L 126-144MM
157B8002	PVAS32-MOUNTING KIT-PVG L 150-168MM
157B8022	PVAS32-MOUNTING KIT-PVG L 174-192MM
157B8003	PVAS32-MOUNTING KIT-PVG L 198-216MM
157B8023	PVAS32-MOUNTING KIT-PVG L 222-240MM
157B8004	PVAS32-MOUNTING KIT-PVG L 246-264MM
157B8024	PVAS32-MOUNTING KIT-PVG L 270-288MM
157B8005	PVAS32-MOUNTING KIT-PVG L 294-312MM
157B8025	PVAS32-MOUNTING KIT-PVG L 318-336MM
157B8006	PVAS32-MOUNTING KIT-PVG L 342-360MM
157B8026	PVAS32-MOUNTING KIT-PVG L 366-384MM
157B8007	PVAS32-MOUNTING KIT-PVG L 390-408MM
157B8027	PVAS32-MOUNTING KIT-PVG L 414-432MM
157B8008	PVAS32-MOUNTING KIT-PVG L 438-456MM
157B8028	PVAS32-MOUNTING KIT-PVG L 462-480MM
157B8009	PVAS32-MOUNTING KIT-PVG L 486-504MM
157B8029	PVAS32-MOUNTING KIT-PVG L 510-528MM
157B8010	PVAS32-MOUNTING KIT-PVG L 534-552MM
157B8030	PVAS32-MOUNTING KIT-PVG L 558-576MM
157B8061	PVAS32-MOUNTING KIT-PVG L 582-600MM
157B8081	PVAS32-MOUNTING KIT-PVG L 606-624MM
157B8062	PVAS32-MOUNTING KIT-PVG L 630-648MM
157B8082	PVAS32-MOUNTING KIT-PVG L 654-672MM

Products we offer:

- Cartridge valves
- DCV directional control valves
- Electric converters
- Electric machines
- Electric motors
- Gear motors
- Gear pumps
- Hydraulic integrated circuits (HICs)
- Hydrostatic motors
- Hydrostatic pumps
- Orbital motors
- PLUS+1® controllers
- PLUS+1® displays
- PLUS+1® joysticks and pedals
- PLUS+1® operator interfaces
- PLUS+1® sensors
- PLUS+1® software
- PLUS+1® software services, support and training
- Position controls and sensors
- PVG proportional valves
- Steering components and systems
- Telematics

Danfoss Power Solutions is a global manufacturer and supplier of high-quality hydraulic and electric components. We specialize in providing state-of-the-art technology and solutions that excel in the harsh operating conditions of the mobile off-highway market as well as the marine sector. Building on our extensive applications expertise, we work closely with you to ensure exceptional performance for a broad range of applications. We help you and other customers around the world speed up system development, reduce costs and bring vehicles and vessels to market faster.

Danfoss Power Solutions – your strongest partner in mobile hydraulics and mobile electrification.

Go to www.danfoss.com for further product information.

We offer you expert worldwide support for ensuring the best possible solutions for outstanding performance. And with an extensive network of Global Service Partners, we also provide you with comprehensive global service for all of our components.

Local address:

Hydro-Gear

www.hydro-gear.com

Daikin-Sauer-Danfoss

www.daikin-sauer-danfoss.com

**Danfoss
Power Solutions (US) Company**
2800 East 13th Street
Ames, IA 50010, USA
Phone: +1 515 239 6000

**Danfoss
Power Solutions GmbH & Co. OHG**
Krokamp 35
D-24539 Neumünster, Germany
Phone: +49 4321 871 0

**Danfoss
Power Solutions ApS**
Nordborgvej 81
DK-6430 Nordborg, Denmark
Phone: +45 7488 2222

**Danfoss
Power Solutions Trading
(Shanghai) Co., Ltd.**
Building #22, No. 1000 Jin Hai Rd
Jin Qiao, Pudong New District
Shanghai, China 201206
Phone: +86 21 2080 6201

Danfoss can accept no responsibility for possible errors in catalogues, brochures and other printed material. Danfoss reserves the right to alter its products without notice. This also applies to products already on order provided that such alterations can be made without subsequent changes being necessary in specifications already agreed. All trademarks in this material are property of the respective companies. Danfoss and the Danfoss logotype are trademarks of Danfoss A/S. All rights reserved.