

Flat Stations

EvoFlat 4.0 M

Domestic hot water and direct heating with mixing loop

Description

Danfoss EvoFlat 4.0 station is particularly suitable for multi family buildings with central heat generation or district heating. The innovative unit sets new standard. It consists of functional blocks made of a specially reinforced PPS composite material. This makes the station extremely lightweight and limits internal heat emission. The smooth surface reduces the risks of scaling and clogging.

All components are assembled with newly designed click-fit connections. Compared to conventional substations with pipes and screw connections, this new connection technology does not require retightening during installation and commissioning.

Primary side (DH)

The flat station is equipped with two differential pressure controller and a central strainer. A summer bypass keeps the supply line warm during standstill. This ensures a fast response time for DHW during the summer. The bypass is thermostatically controlled.

Heating (HE)

The flat station supplies the underfloor heating with a regulated flow temperature, adjustable from 15 °C to 50 °C. The integrated temperature controller and the differential pressure controller create optimal operating conditions. A safety thermostat closes the flow at 55°C A highly efficient circulation pump is installed. A bathroom radiator or towel dryer can be connected using an optional high-temperature connection set.

Domestic hot water (DHW)

Four sizes of heat exchanger are available to cover all requirements from 37 kW up to 70 kW. The Evoflat 4.0 M is equipped with an intelligent controller that regulates the supply side flow based on the domestic hot water temperature and the volume of water drawn. The station features an integrated differential pressure controller on the supply side of the domestic hot water heating system. This eliminates the need for hydraulic balancing of the station. If necessary, the station can be expanded with a hot water circulation set.

Features & benefits

- Light weight
- Easy installation, maintenance and operation
- Durable composite material
- Minimum space required for installation
- Minimal heat loss thanks to EPP insulation cover
- Prepared for build-in heat meter
- Prepared for build-in water meter
- Compatible with various heat sources, such as district heating, heat pumps, biomass etc.

Ordering

Product code numbers

Product Type	Brazing (HEX) copper	Brazing (HEX) Stainless steel
EvoFlat 4.0 M Type 1	183B2000	183B2500
EvoFlat 4.0 M Type 2	183B2001	183B2501
EvoFlat 4.0 M Type 3	183B2002	183B2502
EvoFlat 4.0 M Type 4	183B2003	183B2503

Product code numbers stations with water hammer arrestor

Flat station	Brazing (HEX) copper	Brazing (HEX) Stainless steel
EvoFlat 4.0 M Type 1 WHA	183B2012	183B2512
EvoFlat 4.0 M Type 2 WHA	183B2013	183B2513
EvoFlat 4.0 M Type 3 WHA	183B2014	183B2514
EvoFlat 4.0 M Type 4 WHA	183B2015	183B2515

Danfoss offers flat stations where water hammer arrestor is built in from the factory.

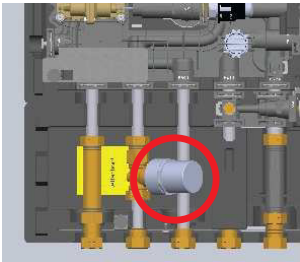

The water hammer resistor is placed at the domestic hot water supply.

Accessories code numbers

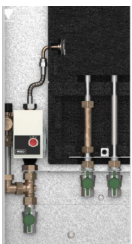

Domestic hot water circulation

If required a set with pump and safety valve (10 bar) can be ordered for easy connection to the flat station. This increases the width of the recess box to at least 690 mm.

Code number	
183B0500	Circulation set EvoFlat 4.0
183B0547	Circulation set EvoFlat 4.0 with insulation shell for circulation pump



High temperature connection set

A high temperature connection set can be used to connect a bathroom towel dryer.

Code number	
183B0501	HTC set for EvoFlat 4.0, with ball valves 3/4" and console
183B0539	HTC flex pipe set for EvoFlat 4.0, connection 3/4"



White steel cover

If the station is to be installed on a wall and a large recess box is not desired, Danfoss offers a steel cover to conceal the station, allowing it to blend seamlessly with a white wall. The cover is simply pressed into place over the EPP.

Code number	Description
004U8578	White steel cover for station RAL 9016



Recess box

Is made of galvanized sheet steel metal, with frame and door powder-coated on both sides in RAL 9016. Appropriate mounting bolts are provided on the rear wall for quick and easy installation of the flat station and distribution unit. The box is closed all around, open at the bottom, and features mounting feet that are height-adjustable by up to 120 mm. A mounting rail with seven ball valves (supplied loose) is included. The box can be mounted in a wall or on a wall.

Recess boxes for installation of flat station and distribution unit in same cabinet.

Recess boxes				
Code number		Wide	Height	Depth
183U6030	Recess box w/mounting rail and loose ball valves	610	1350	150
145H4905	Door + frame for Recess box 183U6030			
183U6031	Recess box w/mounting rail and loose ball valves	690	1350	150
145H4907	Door + frame for Recess box 183U6031			
183U6032	Recess box w/mounting rail and loose ball valves	850	1350	150
145H4909	Door + frame for Recess box 183U6032			
183U6033*	Feet set for recess box			
183L5142*	Ball valve set 3/4" 7 connections			

*Spare parts

On wall panels for recess boxes

Code number		Wide	High	Depth
183U6013	On wall panels	610	1350	150
183U6015	On wall panels	690	1350	150
183U6020	On wall panels	850	1350	150

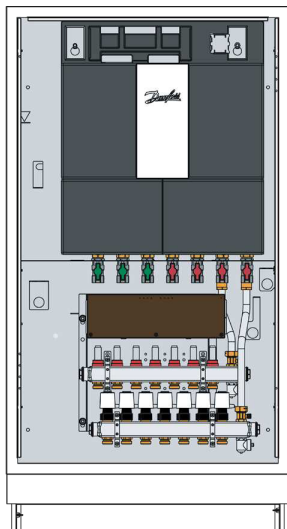

The flat station and the distribution unit fits on the back plate of the recess boxes but can also be mounted on the wall.

Recess boxes for built-in variants are available in three sizes:
2- 9 heating circuits suitable for:

Recess box W 610 / H 1350 / D 150 mm

2- 9 heating circuits with HTC and/or DHW circulation sets suitable for:

Recess box W 690 / H 1350 / D 150 mm

10 heating circuits with or without HTC and/or DHW circulation sets suitable for:

Recess box W 690 / H 1350 / D 150 mm

11- 12 heating circuits with or without HTC and/or DHW circulation sets suitable for:

Recess box W 850 / H 1350 / D 150 mm.

Recess boxes in which only the flat station is installed in the cabinet

Recess boxes				
Code number		Wide	Height	Depth
183U6028	Recess box w/mounting rail and loose ball valves	610	910	150
145H4901	Door + frame for Recess box 183U6028			
183U6029	Recess box w/mounting rail and loose ball valves	690	910	150
145H4903	Door + frame for Recess box 183U6029			
183U6033*	Feet set for recess box			
183L5142*	Ball valve set ¾" 7 connections			

*Spare parts

On wall panels for recess boxes

Code number		Wide	High	Depth
183U6012	On wall panels	610	910	150
183U6014	On wall panels	690	910	150

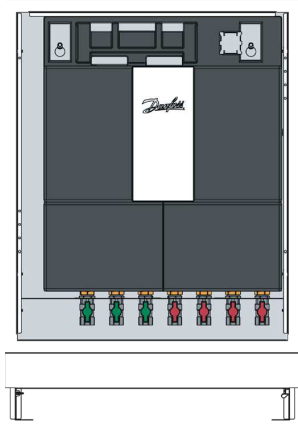

The heating circuit manifolds are designed for installation in a 1350 mm high Recess box below the flat station. Another option is to install the heating circuit manifold in a different location or room within the same apartment (see Danfoss UnoFloor product range).

Recess boxes for built-in variants are available in two sizes:

Flat station suitable for:

Recess box W 610 / H 910 / D 150 mm

Flat station with HTC and/or DHW circulation sets suitable for:

Recess box W 690 / H 910 / D 150 mm.



For on-wall installation, Danfoss Recess boxes can be mounted directly on the wall and covered with appropriate on-wall panels. The on-wall panels are attached magnetically

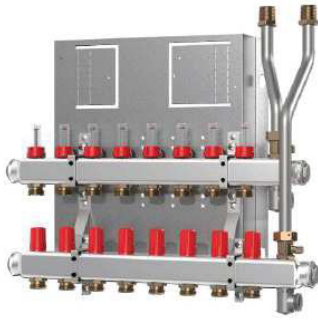

Distribution units SG

Plug and play for easy and quick installation. Finished stainless steel manifold especially designed for Danfoss flat stations. The back plate is mounts directly into the Recess box with pre-drilled screw holes.

It includes manual vent valves, drain valves and flow meters. The heating circuit manifolds are available for 2 to 12 heating circuits.

The SG variant is ordered if you want to install under-floor heating controller and actuators yourself.

Distribution unit SG

Code number	Description
145H0902	Distribution unit SG with 2 heating circuits
145H0903	Distribution unit SG with 3 heating circuits
145H0904	Distribution unit SG with 4 heating circuits
145H0905	Distribution unit SG with 5 heating circuits
145H0906	Distribution unit SG with 6 heating circuits
145H0907	Distribution unit SG with 7 heating circuits
145H0908	Distribution unit SG with 8 heating circuits
145H0909	Distribution unit SG with 9 heating circuits
145H0910	Distribution unit SG with 10 heating circuits
145H0911	Distribution unit SG with 11 heating circuits
145H0912	Distribution unit SG with 12 heating circuits

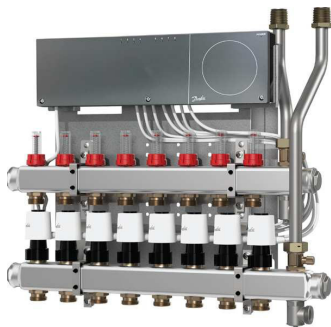

Distribution units SGC

Like the SG variant, but with the Danfoss ICON Wiring Center controller installed. 230V TWA NC thermostatic actuators, pre-wired, for controlling the underfloor heating.

The room thermostats must be wired to the ICON Wiring center on site.

Distribution unit SGC

Code number	Description
145H0922	Distribution unit SGC with 2 heating circuits, ICON Wiring Center and TWA NC 230V
145H0923	Distribution unit SGC with 3 heating circuits, ICON Wiring Center and TWA NC 230V
145H0924	Distribution unit SGC with 4 heating circuits, ICON Wiring Center and TWA NC 230V
145H0925	Distribution unit SGC with 5 heating circuits, ICON Wiring Center and TWA NC 230V
145H0926	Distribution unit SGC with 6 heating circuits, ICON Wiring Center and TWA NC 230V
145H0927	Distribution unit SGC with 7 heating circuits, ICON Wiring Center and TWA NC 230V
145H0928	Distribution unit SGC with 8 heating circuits, ICON Wiring Center and TWA NC 230V
145H0929	Distribution unit SGC with 9 heating circuits, ICON Wiring Center and TWA NC 230V
145H0930	Distribution unit SGC with 10 heating circuits, ICON Wiring Center and TWA NC 230V
145H0931	Distribution unit SGC with 11 heating circuits, ICON Wiring Center and TWA NC 230V
145H0932	Distribution unit SGC with 12 heating circuits, ICON Wiring Center and TWA NC 230V

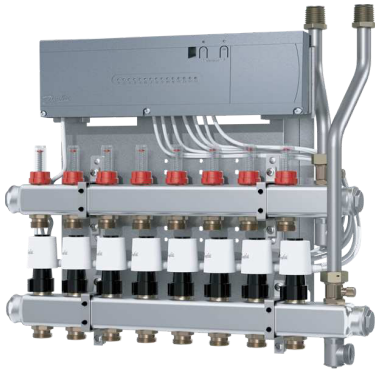

Distribution units SGCI

Like the SG variant, but with the Danfoss ICON2 Advanced Master Controller installed. 230V TWA NC thermotric actuators, pre-wired, for controlling the underfloor heating with automatic hydronic balancing.

Connected to wireless and/or wired room thermostats and can be connected to Danfoss Ally™ for end user control via the Ally Gateway.

Easy commissioning via the Danfoss ICON2 app, which allows the installer to generate a commissionings report.

Distribution unit SGCI

Code number	Description
145H1942	Distribution unit SGCI with 2 heating circuits, ICON2 and TWA NC 230V
145H1943	Distribution unit SGCI with 2 heating circuits, ICON2 and TWA NC 230V
145H1944	Distribution unit SGCI with 2 heating circuits, ICON2 and TWA NC 230V
145H1945	Distribution unit SGCI with 2 heating circuits, ICON2 and TWA NC 230V
145H1946	Distribution unit SGCI with 2 heating circuits, ICON2 and TWA NC 230V
145H1947	Distribution unit SGCI with 2 heating circuits, ICON2 and TWA NC 230V
145H1948	Distribution unit SGCI with 2 heating circuits, ICON2 and TWA NC 230V
145H1949	Distribution unit SGCI with 2 heating circuits, ICON2 and TWA NC 230V
145H1950	Distribution unit SGCI with 2 heating circuits, ICON2 and TWA NC 230V
145H1951	Distribution unit SGCI with 2 heating circuits, ICON2 and TWA NC 230V
145H1952	Distribution unit SGCI with 2 heating circuits, ICON2 and TWA NC 230V



CDM cooling module

The cooling module is installed between the station and the distribution unit and connected to an external cooling supply. It makes both heating and cooling of the apartment via the underfloor heating system possible. A differential pressure controller with flow limiter and integrated control valve with actuator is installed in the supply flow.

Control valves (TWA 230V) in the cooling supply flow for switching between heating and cooling mode, as well as hydraulic separation.

Fitting piece for cooling meter (G 3/4" x 110mm) in the cooling return flow. Strainer in the cooling supply flow.

Code number	
145B9506	CDM cooling module - DN20 AB+PM + DN15 RA-C, 230V
145B9507	CDM cooling module - DN25 AB-PM + DN20 RA-C, 230V

Cooling capacity [kW]	Flow at 4 K [l/h]	Flow at 5 K [l/h]	Flow at 6 K [l/h]	Flow at 7 K [l/h]	Flow at 8 K [l/h]
Standard flow (CDM DN20 HP AB-PM)					
0.5	107		143	123	107
1.0	215	172	184	161	
1.5	322	258	287	246	215
2.0	430	344			
2.5	537	430	358	307	269
3.0	645	516	430	369	322
3.5	752	602	502	430	376
4.0	860	688	573	491	430
4.5			553	484	
5.0			614	537	
5.5					591
High flow (CDM DN25 AB-PM)					
1.5	322	258	287		
2.0	430	344	287		
2.5	537	430	358	307	
3.0	645	516	430	369	322
3.5	752	602	502	430	376
4.0	860	688	573	491	430
4.5	967	774	645	553	484
5.0	1075	860	717	614	537
5.5	1182	946	788	676	591
6.0	1032	860	737	645	
6.5	1118		931	798	699
7.0	1204		1003	860	752
7.5			1075	921	806
8.0			1146	983	860
8.5			1204	1044	914
9.0			1106	967	
9.5				1167	1021
10.0					1075
10.5					
11.0					1182

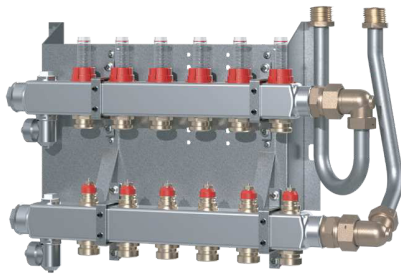

Distribution units SG - CDM

Plug and play for easy and quick installation. Finished stainless steel manifold especially designed for Danfoss flat stations. The back plate is mounted directly into the Recess box with pre-drilled screw holes.

It includes manual vent valves, drain valves and flow meters. The heating circuit manifolds are available for 2 to 12 heating circuits.

The SG variant is ordered if you want to install underfloor heating controller and actuators yourself.

Distribution unit SG - CDM

Code number	Description
145H0862	SG -CDM with 2 heating circuits
145H0863	SG -CDM with 3 heating circuits
145H0864	SG -CDM with 4 heating circuits
145H0865	SG -CDM with 5 heating circuits
145H0866	SG -CDM with 6 heating circuits
145H0867	SG -CDM with 7 heating circuits
145H0868	SG -CDM with 8 heating circuits
145H0869	SG -CDM with 9 heating circuits
145H0870	SG -CDM with 10 heating circuits
145H0871	SG -CDM with 11 heating circuits
145H0872	SG -CDM with 12 heating circuits

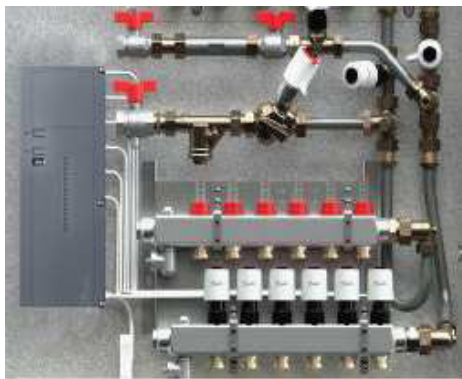

Distribution units SGCI -CDM

Like the SG variant, but with the Danfoss ICON2 Advanced Master Controller installed. 230V TWA NC thermotic actuators, pre-wired, for controlling the underfloor heating with automatic hydronic balancing. Connected to wireless and/or wired room thermostats and can be connected to Danfoss Ally™ for end user control via the Ally Gateway. Easy commissioning via the Danfoss ICON2 app, which allows the installer to generate a commissioning report. The master controller is mounted in the Recess box with magnets.







Distribution unit SGCI - CDM

Code number	Description
145H1882	SGCI -CDM with 2 heating circuits, ICON 2, 230V
145H1883	SGCI -CDM with 3 heating circuits, ICON 2, 230V
145H1884	SGCI -CDM with 4 heating circuits, ICON 2, 230V
145H1885	SGCI -CDM with 5 heating circuits, ICON 2, 230V
145H1886	SGCI -CDM with 6 heating circuits, ICON 2, 230V
145H1887	SGCI -CDM with 7 heating circuits, ICON 2, 230V
145H1888	SGCI -CDM with 8 heating circuits, ICON 2, 230V
145H1889	SGCI -CDM with 9 heating circuits, ICON 2, 230V
145H1890	SGCI -CDM with 10 heating circuits, ICON 2, 230V
145H1891	SGCI -CDM with 11 heating circuits, ICON 2, 230V
145H1892	SGCI -CDM with 12 heating circuits, ICON 2, 230V

Room thermostats for Danfoss ICON Wiring center

Wired room sensors are available for built-in or on wall installation.

Wired solution - Distribution units SGC with ICON Wiring Center installed

Code number		
088U1000	Danfoss ICON™ Dial, In-wall	
088U1010	Danfoss ICON™ Display, In-wall	
088U1020	Danfoss ICON™ Programable, In-wall	
088U1005	Danfoss ICON™ Dial, On-wall	
088U1015	Danfoss ICON™ Display, On-wall	
088U1025	Danfoss ICON™ Programable, On-wall	
088U1110	Floor sensor	







Room thermostats for Danfoss ICON2 Advanced Master controller

Wired or wireless room sensors are available for built-in or on wall installation.

If wired room thermostats are used, they can be connected in a Daisy chain, as registration is done via their MAC address.

An Ally™ gateway can be purchased, allowing the user to control the room heating (or cooling) via a Danfoss Ally™ user app.

Wireless/wired solution - Distribution unit SGCI - CDM with ICON2 Advanced Master controller

Code number		
088U2121	Danfoss ICON2™ RT display thermostat Wireless	
088U2122	Danfoss ICON2™ Featured RT display thermostat with infrared floor sensor Wireless	
088U2120	Danfoss ICON2™ Sensor, no settings or display Wireless	
088U2128	Danfoss ICON2™ On-wall thermostat 2-wire 24V	
088U2125	Danfoss ICON2™ In-wall thermostat 2-wire 24V	
088U1110	Floor sensor	
014G2400	Danfoss Ally™ Gateway (for user-app)	

Product details

General data

Circuit diagram

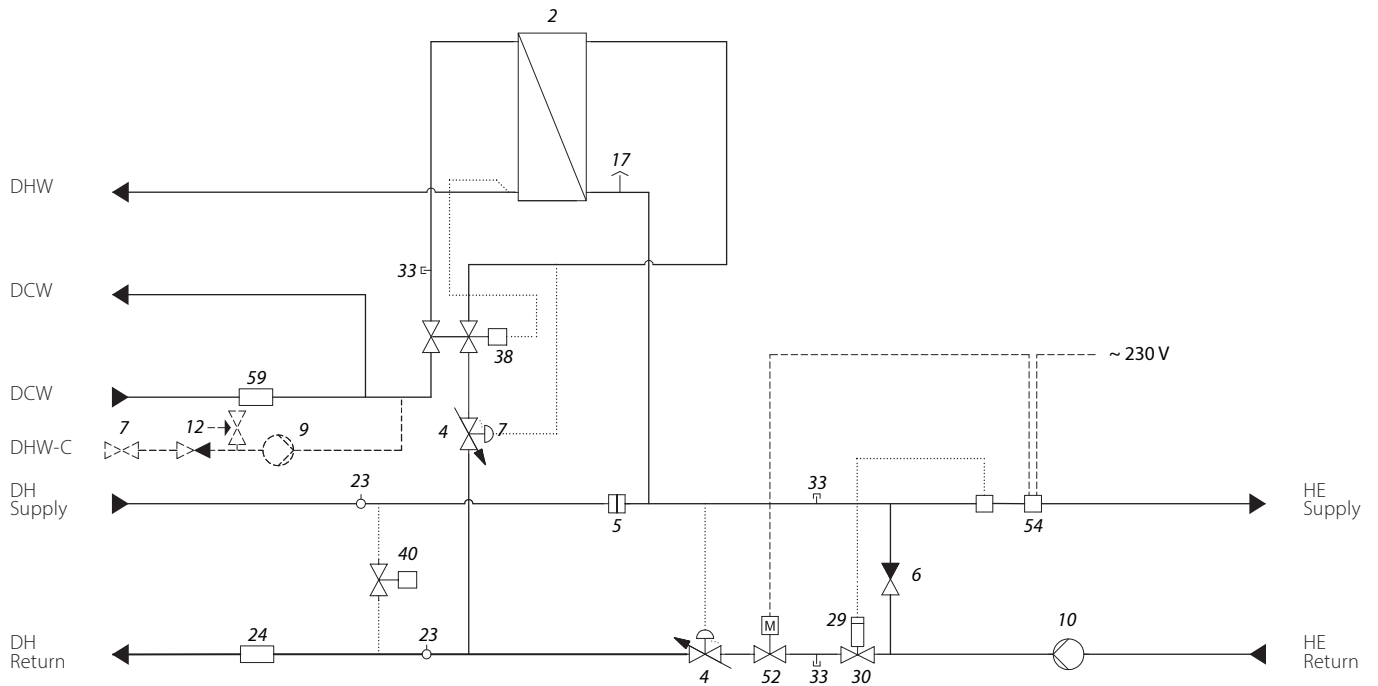

2	DHW plate heat exchanger
4	Differential pressure controller
5	Strainer
6	Check valve
7	Ball valve*
9	DHW circulation pump*
10	Heating pump mixing circuit
12	Safety valve*
17	Air vent
23	Sensor pocket

24	Fitting piece for energy meter $\frac{3}{4}'' \times 110$ mm
29	Temperature sensor
30	Valve HE
33	Plug for high temperature circuit (HTC)
38	Hot water controller
40	Summer bypass
52	Zone valve TWA*
54	Safety thermostat
59	Fitting piece for water meter $\frac{3}{4}'' \times 110$ mm
*Optional	

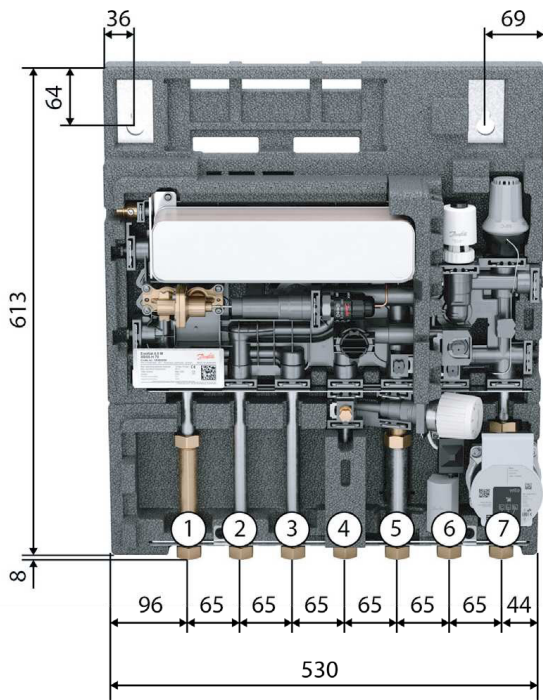

No.	Connection Description
1	Domestic cold water (DCW) inlet
2	Domestic hot water (DHW) supply
3	Domestic cold water (DCW) outlet
4	Heating source (DH) supply
5	Heating source (DH) return
6	Floor heating (HE) supply
7	Floor heating (HE) return

Technical data

Domestic hot water controller	Flow compensated temperature controller
Nominal pressure	PN10
Max. supply temperature (DH)	95 °C
DCW static cold water	$P_{\min} = 1.5 \text{ bar}$
Brazing (HEX)	Copper or stainless steel
Insulation	EPP $\lambda 0.039$
Electrical supply	230 V AC
Connection sizes	G $\frac{3}{4}$ " internal thread
Pressure nominal primary	10 bar
Pressure nominal secondary	10 bar
Weight without accessories - Type 1 HEX	12.2 kg
Weight without accessories - Type 2 HEX	13.3 kg
Weight without accessories - Type 3 HEX	13.8 kg
Weight without accessories - Type 4 HEX	14.6 kg

Capacity

DHW capacity examples at 10/50 °C

Unit type HEX	DHW capacity [kW]	Temperature DHS/DHR [°C]	Flow rate primary [l/h]	Pressure loss Primary* [kPa]	Tap load 50 °C [l/min]
Type 1	37	65/15	637	25	13.3
	45	65/17	820	31	16.2
Type 2	45	65/15	770	29	16.2
	50	65/17	896	33	18.0
Type 3	55	65/16	978	39	19.8
	40	53/24	1205	57	14.4
Type 4	60	65/16	1056	38	21.6
	70	65/14	1197	57	25.2
	45	53/23	1310	63	16.2

*Energy meter not included

Heating capacity examples

Heating capacity [kW]	Heating circuit ΔT [°C]	Total pressure loss primary* [kPa]	Flow rate supply [l/h]
10	20	12	430
10	25	8	344
10	30	6	287
10	35	5	246
10	40	4	215
17.5	30	20	500**

*Energy meter and DHW heating not included

**Max. flow

Pressure and temperature data

Flowrate type 1 HEX

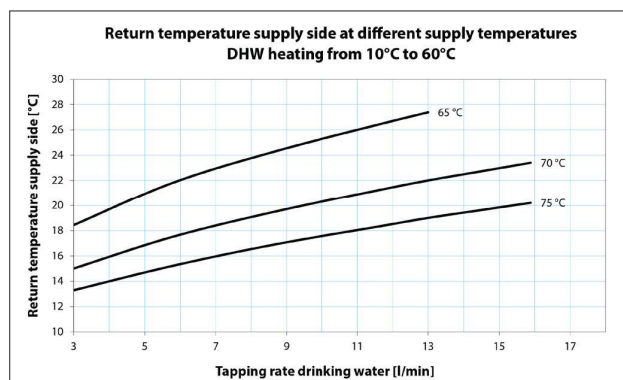
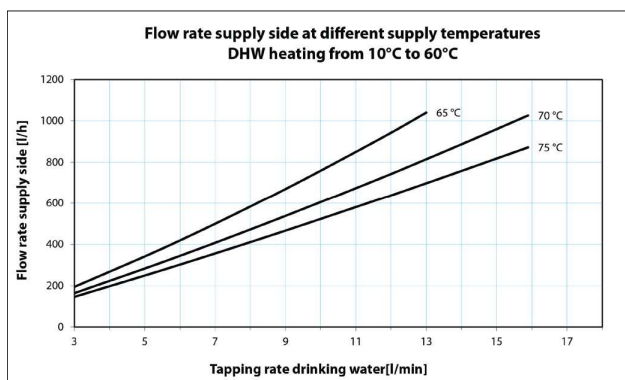
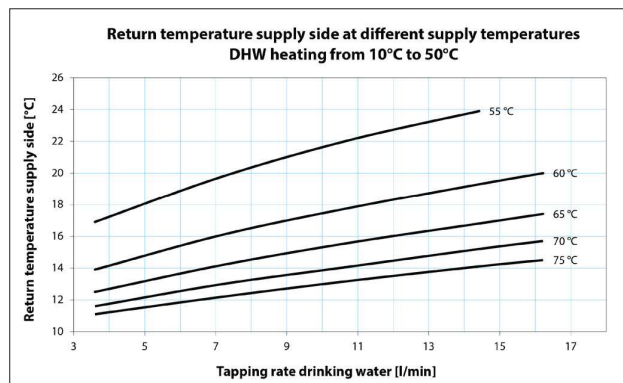
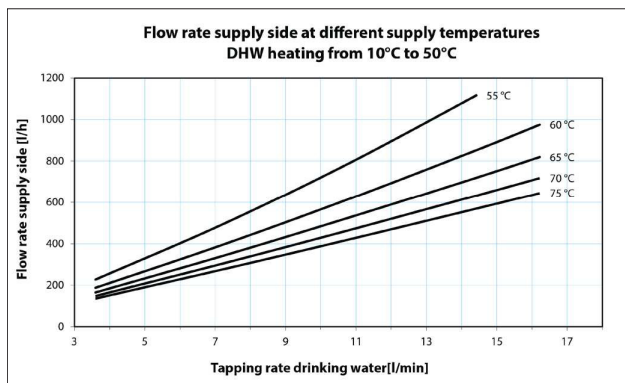
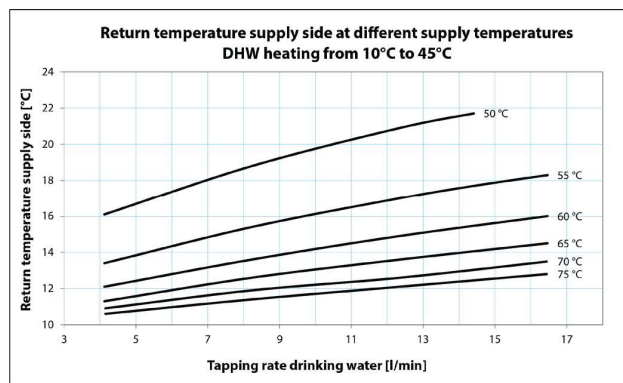
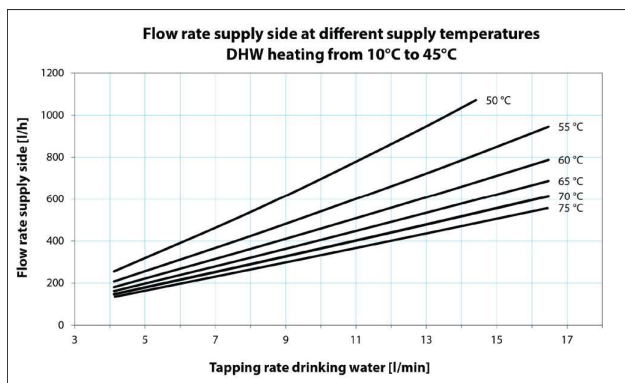
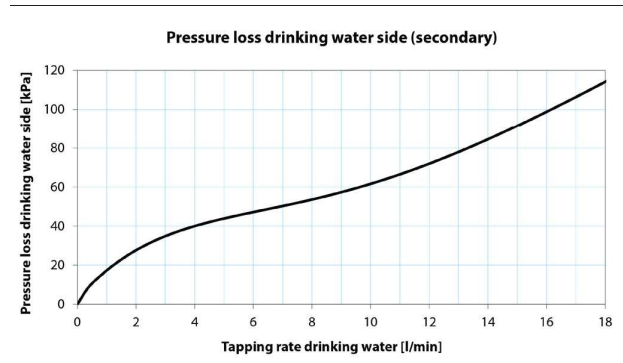
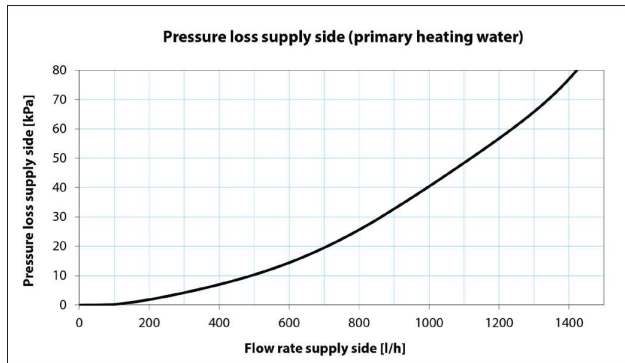

Flowrate type 2 HEX

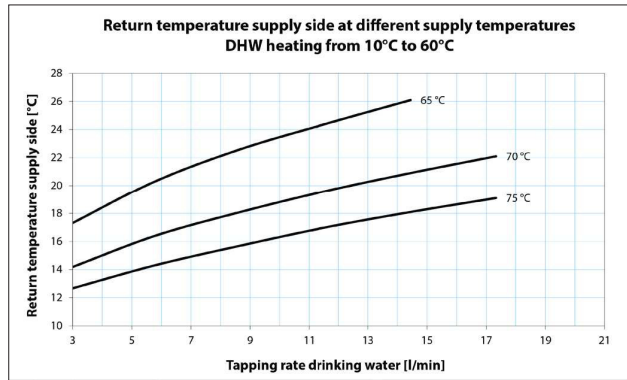
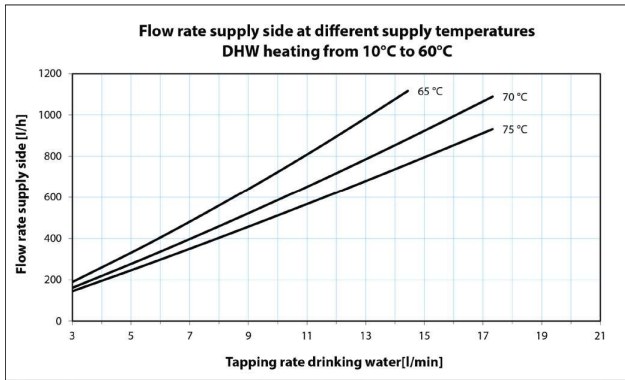
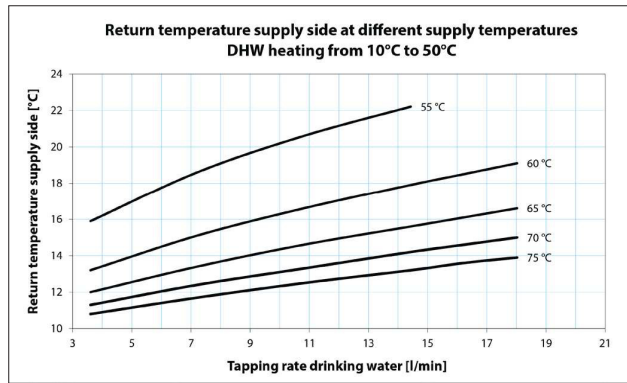
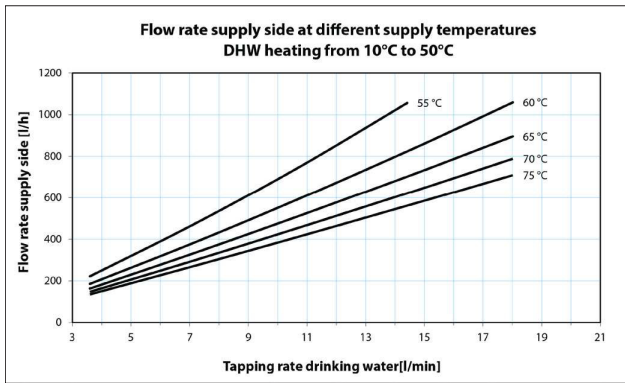
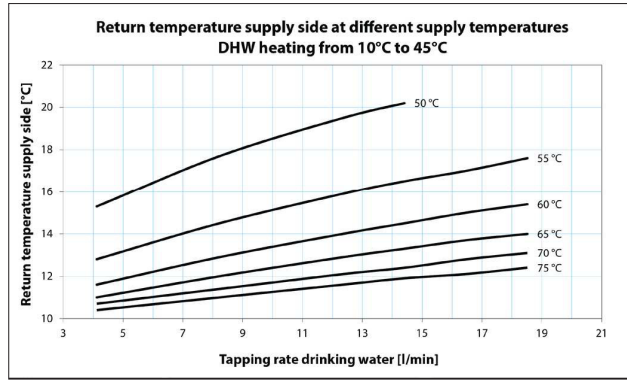
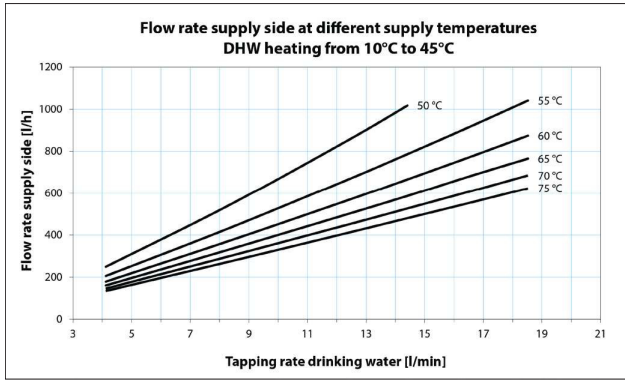
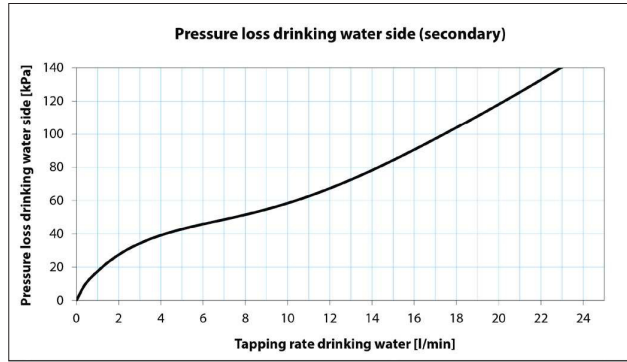
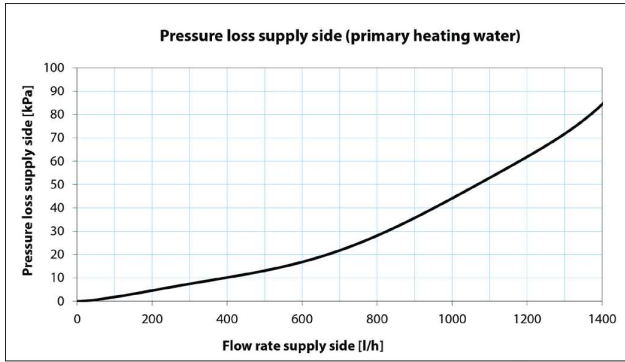

Flowrate type 3 HEX

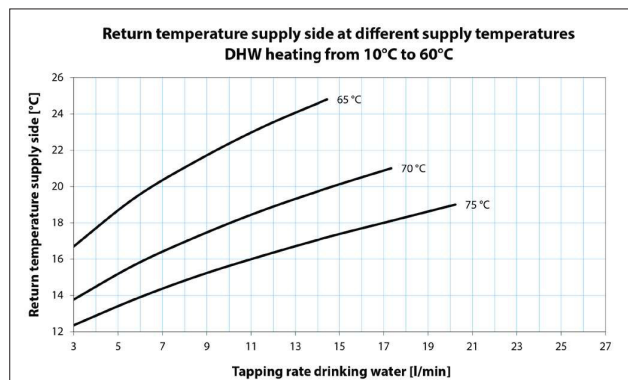
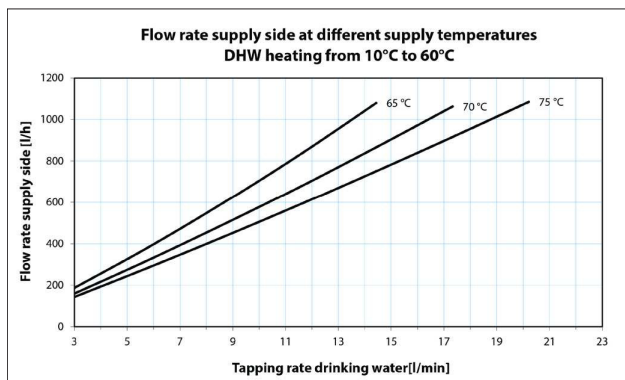
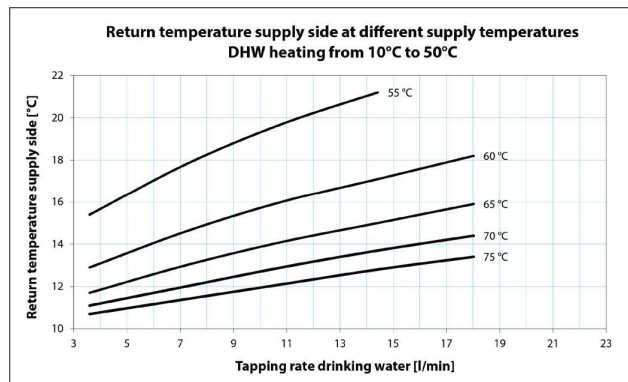
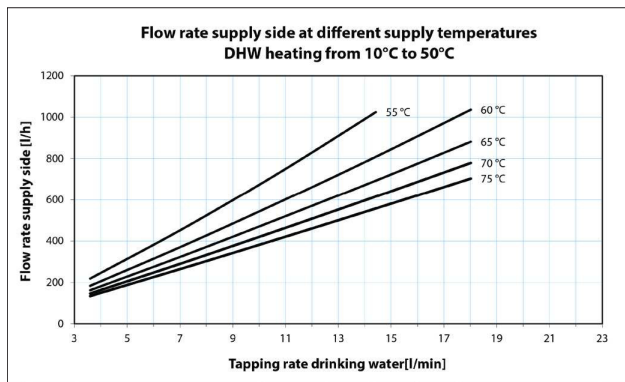
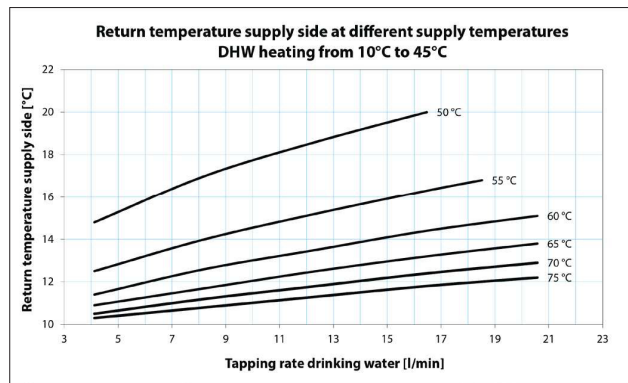
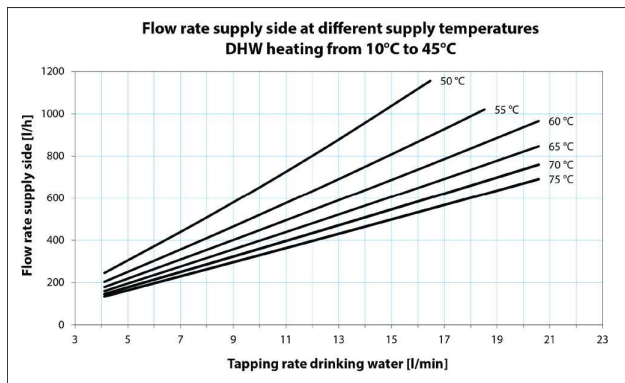
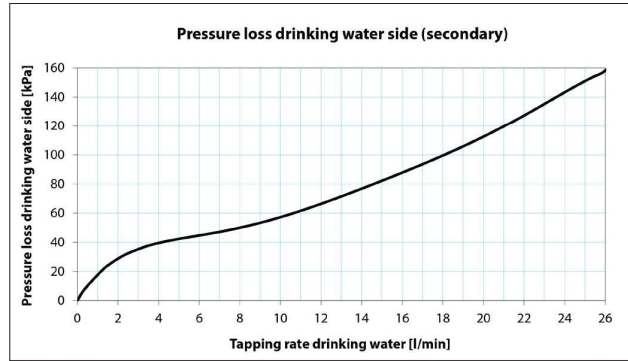
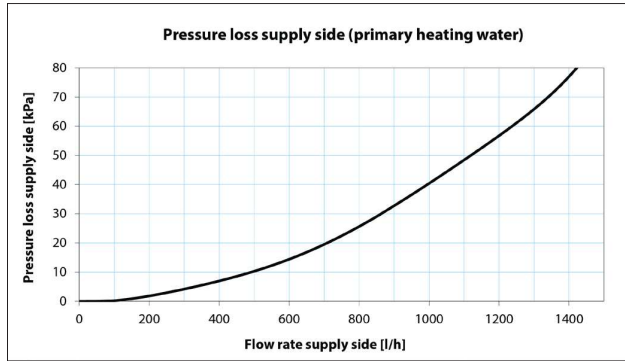

Flowrate type 4 HEX

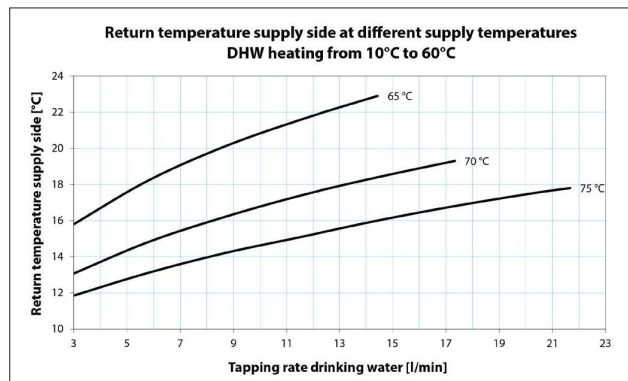
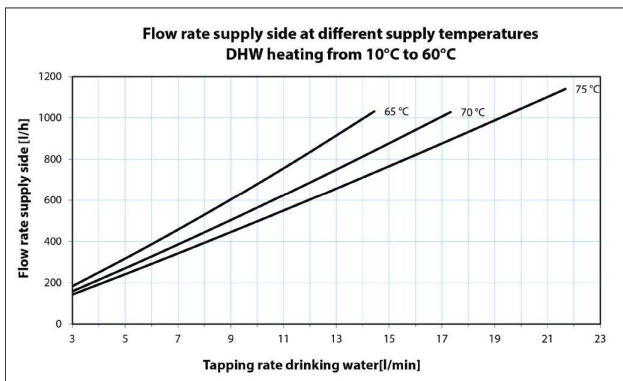
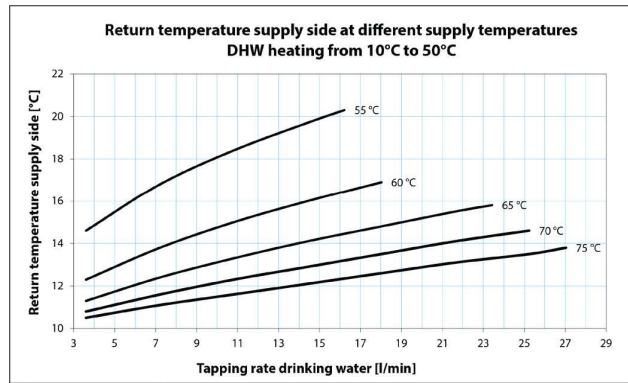
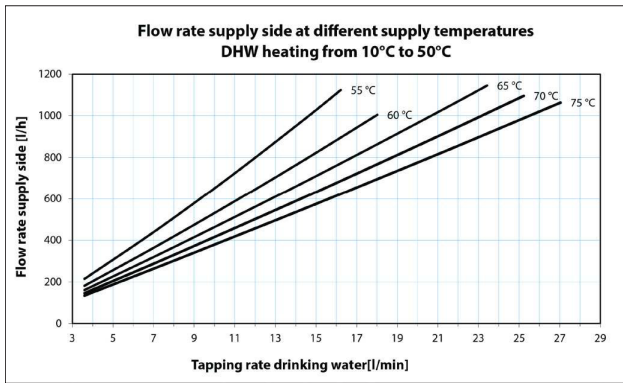
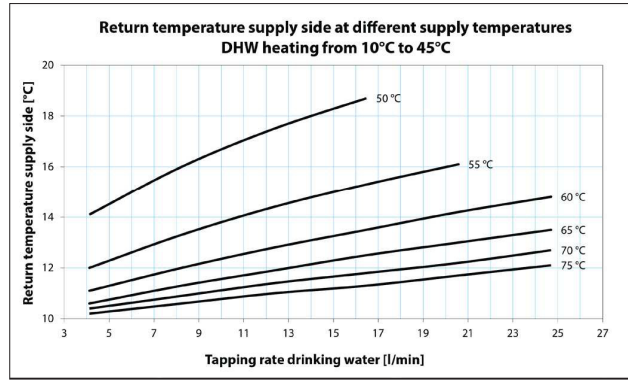
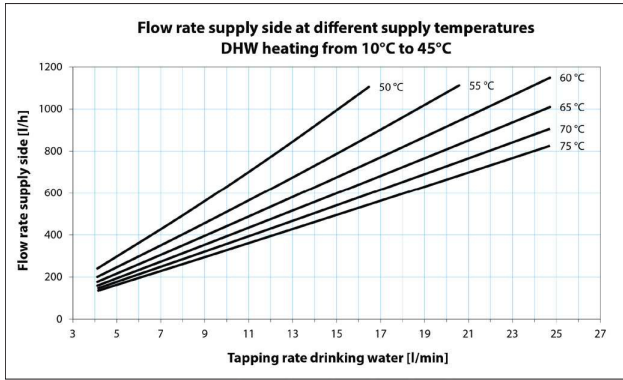
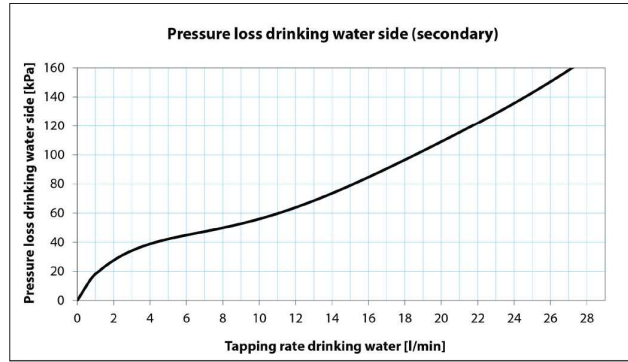
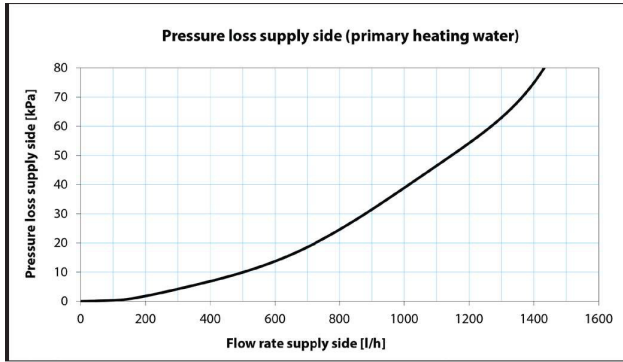

Guidelines for water quality

Danfoss has prepared this guideline for the water quality of tap water and district heating water used in plate heat exchangers of stainless steel (EN 1.4404 ~ AISI 316L) brazed with pure Copper (Cu), CoResist (Cn) or Stainless Steel (StS). It is important to point out that the water specification is not a guarantee against corrosion, but it must be considered as a tool to avoid the most critical water applications.

Parameter	Unit	Value or concentration	Plate	Brazing material	
			AISI 316L W. Nr. 1.4404	Cu	StS
pH		< 0.6	o	-	o
		6.0 – 7.5	+	o/-	+
		7.5 – 10.5	+	+	+
		> 10.5	+	o	+
Conductivity	μS/cm	< 10	+	+	+
		10 – 500	+	+	+
		500 – 1000	+	o	+
		> 1000	+	-	+
Free Chlorine	mg/l	< 0.5	+	+	+
		0.5 – 1	o	+	+
		1 – 5	-	o	o
		> 5	-	-	-
Ammonia (NH ₃ , NH ₄ ⁺)	mg/l	< 2	+	+	+
		2 – 20	+	o	+
		> 20	+	-	+
Alkalinity (HCO ₃ ⁻)	mg/l	< 60	+	+	+
		60 – 300	+	+	+
		> 300	+	o	+
Sulphate (SO ₄ ²⁻)	mg/l	< 100	+	+	+
		100 – 300	+	o/-	+
		> 300	+	-	+
HCO ₃ ⁻ / SO ₄ ²⁻	mg/l	< 1.5	+	+	+
		> 1.5	+	o/-	+
Nitrate (NO ₃)	mg/l	< 100	+	+	+
		> 100	+	o	+
Manganese (Mn)	mg/l	< 0.1	+	+	+
		> 0.1	+	o	+
Iron (Fe)	mg/l	< 0.2	+	+	+
		> 0.2	+	o	+
[Ca ²⁺ , Mg ²⁺ +1/[HCO ₃ ⁻ 1*		0 – 0.3	+	-	+
		0.3 – 0.5	+	o/-	+
		> 0.5	+	+	+

+	Good corrosion resistance
o	**Corrosion could happen when more parameters are evaluated with o
o/-	Risk of corrosion
-	Use is not recommended

* Hardness ration limits defined per experience and internal tests in Danfoss laboratory

** In case of three or more parameters evaluated with o consultancy is needed with Consultant for Corrosion & Microbiology or BU HHE Representative

Recommended Chloride concentration to avoid Stress Corrosion Cracking (SCC) in the stainless steel plates:



Application temperature	Chloride concentration
at T ≤ 20 °C	max 1000 mg/l
at T ≤ 50 °C	max 400 mg/l
at T ≤ 80 °C	max 200 mg/l
at T ≥ 100 °C	max 100 mg/l

Spare part code numbers:

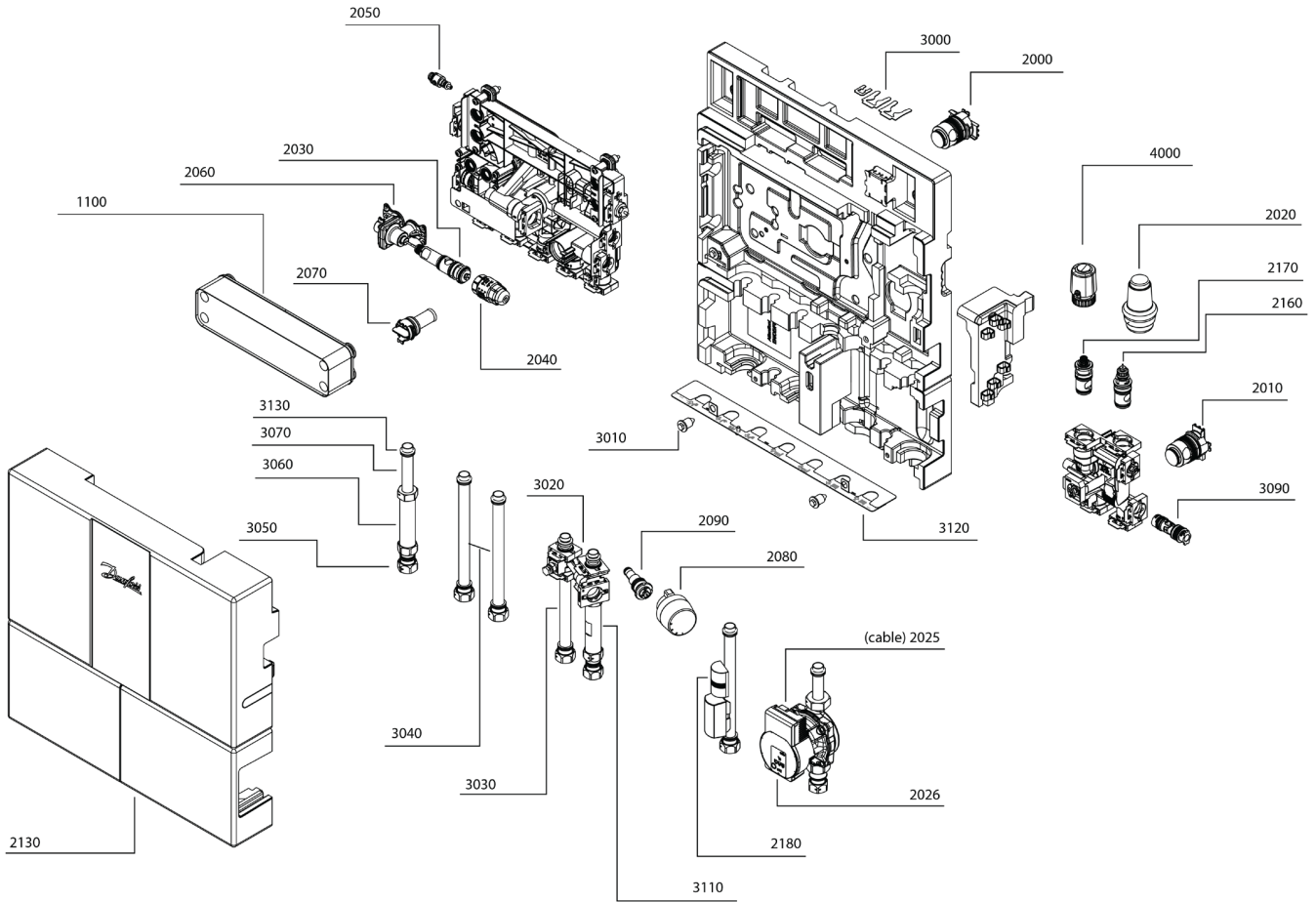

Pos.	Code number	Description
1100	183B0503	Service kit type 1 heat exchanger in copper
1100	183B0504	Service kit type 2 heat exchanger in copper
1100	183B0505	Service kit type 3 heat exchanger in copper
1100	183B0506	Service kit type 4 heat exchanger in copper
1100	183B0507	Service kit type 1 heat exchanger in stainless steel
1100	183B0508	Service kit type 2 heat exchanger in stainless steel
1100	183B0509	Service kit type 3 heat exchanger in stainless steel
1100	183B0510	Service kit type 4 heat exchanger in stainless steel
2000	183B0563	Dp regulator DHW EvoFlat 4.0 SAC
2010	183B0564	Dp regulator HE EvoFlat 4.0 SAC
2020	013G5081	FTC thermostat 15-50 °C
2025	145H4074	Plug for Wilo Yonos Para 1.5 m cable
2026	145H4296	Wilo pump Yonos Para RS 15/61"
2030	183B0511	DHW control valve set EvoFlat 4.0 SAC
2040	183B0512	DHW control thermostat set EvoFlat 4.0 SAC
2050	183B0513	Air vent set Danfoss EvoFlat 4.0
2060	183B0514	Flow activator with screws and gaskets
2070	183B0515	Strainer set EvoFlat 4.0
2080		FJVR thermostat
2090	183B0517	Bypass valve thermostatic EvoFlat 4.0 SAC
2130	183B0521	EPP cover set Danfoss EvoFlat 4.0
2160	183B0527	HE valve set EvoFlat 4.0 SAC
2170	183B5029	Zone valve set EvoFlat 4.0 SAC
2180	183B0542	Safety temperature switch + TWA-Q-NO EvoFlat 4.0 SAC (4000)
3000	183B0552	Bracket kit for EvoFlat 4.0
3010	183B0553	Plast screw 15x25
3020	183B0554	Block for bypass EvoFlat 4.0
3030	183B0555	Pipe Ø18 - 171 mm
3040	183B0556	Pipe Ø18 - 223 mm
3050	183B0557	Bushing w/nuts ¾" x ¾" x 32 mm
3060	183B0558	Fitting piece ¾" x 110 mm - DHW
3070	183B0559	Pipe Ø18 - 77 mm
3090	183B0561	Checkvalve for EvoFlat 4.0
3110	183B0565	Fitting piece ¾" x 110 mm - HE
3120	183B0566	Mounting rail with symbols for EvoFlat 4.0
3130	183B0560	Clips, O-rings & washers for EvoFlat 4.0
4000	082F1601	Zone valve, TWA-Q-NO
	183B0533	Flushing Tool EvoFlat 4.0 HEX

Certificates, declarations and approvals

The list contains all certificates, declarations, and approvals for this product type. Individual code number may have some or all of these approvals, and certain local approvals may not appear on the list.

When you click on the link you will be directed to the latest version of the 'Declaration of Conformity'. Products developed and sold before this date of issue conform to the directives/standards in force at the time of their sale.

Approval type	Title	Certification body	Approval topic
Hygienic Certificate	CARSO 25 ACC LY 385	CARSO - Laboratoire Santé Environnement Hygiène de Lyon	Drinking Water
Export Control Declaration	Export Control Declaration - Small stations	Danfoss	
Hygienic Certificate	Eurofins Certificate No 014-01	eurofin - eurofin Product Service GmbH	Drinking Water

Tender text

Tender text Copper HEX

Design

Danfoss EvoFlat™ flat station for direct heating and hygienic safe hot water provision with a control valve without auxiliary energy in the continuous flow system. Mounted on a heat-insulated base plate including EPP heat insulation hood, for flush or surface mounting.

Domestic hot water (DHW)

Tap water is heated by means of heat exchangers based on the continuous flow principle. The tap water temperature is regulated by the self-acting controller. These controllers ensure outstanding ease of use. The flow-controlled part allows primary and secondary flow through the heat exchanger only during hot water tapping. The flow is blocked immediately after completion of hot water tapping.

The thermostat part in turn regulates the hot water temperature.

Thanks to the fast-acting control valve, limescale deposits and bacteria growth are largely avoided.

The controller in combination with the differential pressure controller ensures a constant DHW temperature even with varying flow temperatures and differential pressures.

The primary line is kept warm by a thermostatically controlled bypass valve (summer bypass).

The flat station is equipped with a connection for domestic hot water circulation. The circulation kit is available as an option.

Heating (HE)

The mixing circuit for surface heating temperature control, consisting of a mechanical control group with a second integrated differential pressure controller for setting the FBH flow temperature, non-return valve and high-efficiency circulation pump (energy efficiency index EEI ≤ 0.20). Safety device for flow temperature monitoring by Danfoss safety thermostat (55 °C). If the temperature is too high, the integrated zone valve is closed by a servomotor.

The flat station is equipped with a connection for a second heating circuit on the high temperature circuit. The high temperature connection set is available as an option.

Supply-side equipment

Temperature and pressure regulators, two differential pressure regulators, zone valve, strainer and ventilation

Mark: Danfoss

Thermal actuator, 230 V, normally open

Mark: Danfoss

Type: TWA- Q 230 V NO

Fitting piece for heat meter G³/₄"x110 mm in return flow, sensor holder as direct immersion sensor M10x1mm

Heat exchanger

Seal less stainless steel plate heat exchanger, copper brazed under vacuum to form a compact unit. New Micro Plate™ heat exchanger technology with unique plate structure for more effective heat transfer, lower pressure losses and longer service life. Corrosion resistant design.

Calculation and materials according to AD data sheets. Manufactured in accordance with DIN ISO 9001, CE tested in accordance with Pressure Equipment Directive 97/23/EC (PED).

Mark: Danfoss

Type: XB05H

Consumer-side equipment

Connection for static heating circuit (high temperature circuit) speed-controlled high-efficiency circulation pump:

Mark: Wilo

Type: Para 15– 130/6

Non-return valve in bypass.

Fixed value controller without auxiliary energy

Mark: Danfoss FTC

Safety thermostat

Mark: Danfoss

Tap-water-side equipment

Fitting piece for cold water meter G $\frac{3}{4}$ "x110mm (CW inlet)

Technical data

Heating	
max. capacity [kW]:	17.5
at max. volume flow [m ³ /h]:	0.5 (supply side) / 1.29 (consumer side)
Tap water heating max. capacity [kW]:	45 @ VL65 °C (Type 1 HEX)
at max. tapping capacity [l/min]:	13.2
max. capacity [kW]:	53 @ VL65 °C (Type 2 HEX)
at max. tapping capacity [l/min]:	15.4
max. capacity [kW]:	60 @ VL65 °C (Type 3 HEX)
at max. tapping capacity [l/min]:	17.4
max. capacity [kW]:	80 @ VL65 °C (Type 4 HEX)
at max. tapping capacity [l/min]:	28.3
Pressure level (tap water side):	PN10
Pressure level (supply side):	PN10
DH network, max. differential pressure [bar]:	4
CW network, min. static pressure [bar]:	1.5
DH network, max. flow temperature [°C]:	95
Nominal connection size:	G $\frac{3}{4}$ " (union, 7x)
Electrical connection:	230 V AC
Dimensions H/W/D [mm]:	613/530/150
Weight [kg]:	9.2 (Type 1 HEX) 9.7 (Type 2 HEX) 10.3 (Type 3 HEX) 10.8 (Type 4 HEX)

Stainless steel HEX

Danfoss EvoFlat™ flat station for direct heating and hygienic safe hot water provision with a control valve without auxiliary energy in the continuous flow system. Mounted on a heat-insulated base plate including EPP heat insulation hood, for flush or surface mounting.

Domestic hot water (DHW)

Tap water is heated by means of heat exchangers based on the continuous flow principle. The tap water temperature is regulated by the self-acting controller. These controllers ensure outstanding ease of use. The flow-controlled part allows primary and secondary flow through the heat exchanger only during hot water tapping. The flow is blocked immediately after completion of hot water tapping. The thermostat part in turn regulates the hot water temperature.

Thanks to the fast-acting control valve, limescale deposits and bacteria growth are largely avoided.

The controller in combination with the differential pressure controller ensures a constant DHW temperature even with varying flow temperatures and differential pressures.

The primary line is kept warm by a thermostatically controlled bypass valve (summer bypass).

The flat station is equipped with a connection for domestic hot water circulation. The circulation kit is available as an option.

Heating (HE)

The mixing circuit for surface heating temperature control, consisting of a mechanical control group with a second integrated differential pressure controller for setting the FBH flow temperature, non-return valve and high-efficiency circulation pump (energy efficiency index $EI \leq 0.20$). Safety device for flow temperature monitoring by Danfoss safety thermostat (55 °C). If the temperature is too high, the integrated zone valve is closed by a servomotor.

The flat station is equipped with a connection for a second heating circuit on the high temperature circuit. The high temperature connection set is available as an option.

Supply-side equipment

Temperature and pressure regulators, two differential pressure regulators, zone valve, strainer and ventilation

Mark: Danfoss

Thermal actuator, 230 V, normally open

Mark: Danfoss

Type: TWA- Q 230 V NO

Fitting piece for heat meter $G\frac{3}{4}$ "x110mm in return flow, sensor holder as direct immersion sensor M10x1mm

Heat exchanger

Sealles stainless steel plate heat exchanger, brazed with stainless steel braze under vacuum to form a compact unit. New Micro Plate™ heat exchanger technology with unique plate structure for more effective heat transfer, lower pressure losses and longer service life. Corrosion resistant design.

Calculation and materials according to AD data sheets. Manufactured in accordance with DIN ISO 9001, CE tested in accordance with Pressure Equipment Directive 97/23/EC (PED).

Mark: Danfoss

Type: XB05H

Consumer- side equipment

Connection for static heating circuit (high temperature circuit) speed-controlled high-efficiency circulation pump:

Mark: Wilo

Type: Para 15 – 130/6

Non-return valve in bypass.

Fixed value controller without auxiliary energy

Mark: Danfoss FTC

Safety thermostat

Mark: Danfoss

Tap-water-side equipment

Fitting piece for cold water meter G³/₄"x110mm (CW inlet)

Technical data

Heating	
max. capacity [kW]:	0.5
at max. volume flow [m ³ /h]:	(supply side) / 1.29 (consumer side)
Tap water heating max. capacity [kW]:	45 @ VL65 °C (Type 1 HEX)
at max. tapping capacity [l/min]:	13.2
max. capacity [kW]:	53 @ VL65 °C (Type 2 HEX)
at max. tapping capacity [l/min]:	15.4
max. capacity [kW]:	60 @ VL65 °C (Type 3 HEX)
at max. tapping capacity [l/min]:	17.4
max. capacity [kW]:	80 @ VL65 °C (Type 4 HEX)
at max. tapping capacity [l/min]:	28.3
Pressure level (tap water side):	PN10
Pressure level (supply side):	PN10
DH network, max. differential pressure [bar]:	4
CW network, min. static pressure [bar]:	1.5
DH network, max. flow temperature [°C]:	95
Nominal connection size:	G ³ / ₄ " (union, 7x)
Electrical connection:	230V AC
Dimensions H/W/D [mm]:	613/530/150
Weight [kg]:	9.2 (Type 1 HEX)
	9.7 (Type 2 HEX)
	10.3 (Type 3 HEX)
	10.8 (Type 4 HEX)

Other stations in this portfolio

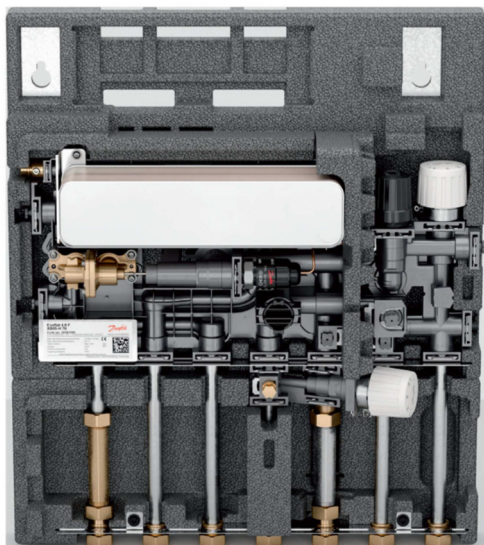

EvoFlat 4.0 F

Flat station for domestic hot water and radiator heating.

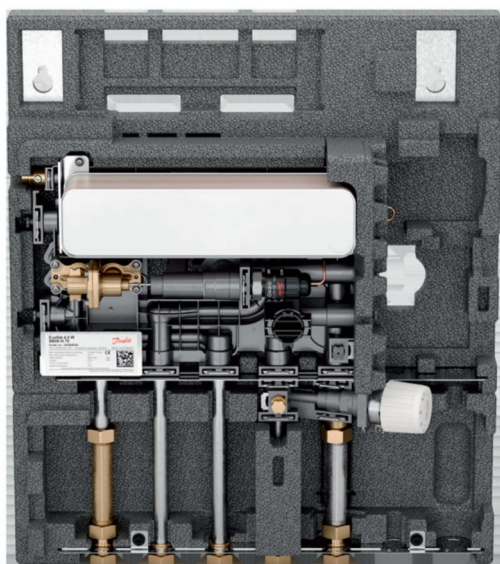

EvoFlat 4.0 W

Flat station for domestic hot water.

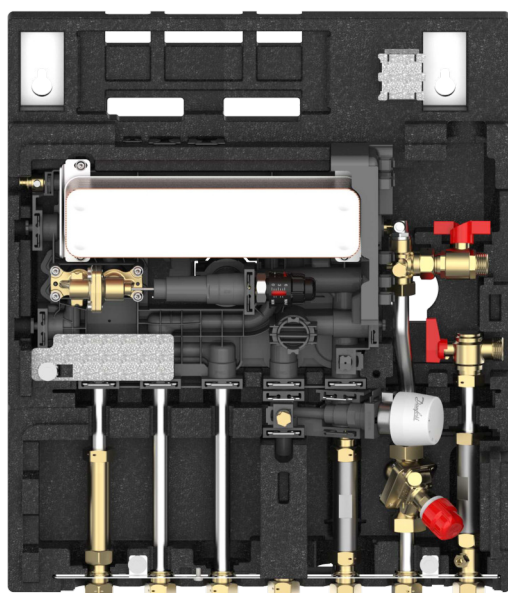

EvoFlat 4.0 Four pipe

Flat station for domestic hot water and floor heating. Especially made for heat pumps.

Contact details

Online support

Danfoss offers a wide range of support along with our products, including digital information, software, mobile apps and expert guidance. See the possibilities below.



The Danfoss Design center

Discover the Design Center, our advanced digital platform that streamlines product selection. With integrated tools and enhanced type pages, it's simpler than ever to access product information and documentation, and to select the right products. Check the availability of Danfoss products at partner locations and enjoy seamless transitions from selection to purchase with our basket-to-basket functionality. Whether you're buying from our distributors or directly from the Product Store, the Design Center simplifies your experience. Learn more at: designcenter.danfoss.com.



The Danfoss product store

The Danfoss Product Store is a one-stop shop available 24/7 for our customers, no matter where you are in the world or what area of industry you work in. Browse our catalog, check product details and documentation, view your prices and product availability, and quickly finalize your purchase. Start browsing at: store.danfoss.com.



Danfoss Partner Portal/Product Data tool

Designed to support you with easy access to product data extracts, essential resources, tools, and information. The Partner Portal provides a centralized hub for product documentation, training materials, marketing assets, and technical support, ensuring you have everything you need to succeed and grow your business with Danfoss. The Partner Portal is available 24/7 at: partner.danfoss.com and is ready to support your business.



Find technical documentation

Find technical documentation you need to get your project up running. Get direct access to our official collection of data sheets, certificates and declarations, manuals and guides, 3D models and drawings, case stories, brochures, and much more. Start searching now at: documentation.danfoss.com.



Danfoss Learning

Danfoss Learning is a free online learning platform. It features courses and materials specifically designed to help engineers, installers, service technicians, and wholesalers better understand the products, applications industry topics, and trends that will help you do your job better. Find your local Danfoss website here: learning.danfoss.com.



Get local information and support

Local Danfoss websites are the main sources for help and information about our company and products. Find product availability, get the latest regional news, or connect with a nearby expert - all in your own language. Find your local Danfoss website here: danfoss.com.

Danfoss A/S

Climate Solutions . danfoss.com . +45 7488 2222

Any information, including, but not limited to information on selection of product, its application or use, product design, weight, dimensions, capacity or any other technical data in product manuals, catalogues description, advertisements, etc. and whether made available in writing, orally, electronically, online or via download, shall be considered informative, and is only binding if and to the extent, explicit reference is made in a quotation or order confirmation. Danfoss cannot accept any responsibility for possible errors in catalogues, brochures, videos and other material. Danfoss reserves the right to alter its products without notice. This also applies to products ordered but not delivered provided that such alterations can be made without changes to form, fit or function of the products. All trademarks in this material are property of Danfoss A/S or Danfoss group companies. Danfoss and the Danfoss logo are trademarks of Danfoss A/S. All rights reserved.
