

Technical paper

Retrofit and High Glide Refrigerants

Danfoss statement

**By Norbert Blatz, Global Application Excellence Manager,
John Broughton, Global Application Expert, Commercial Refrigeration,
Rasmus Damgaard Poulsen, Specialist, Global Laboratory Technology, Ph.D. Chemistry,
Thierry Legay, Application Excellence Manager.
Danfoss Cooling, September 2016**

This collection of documents will inform and guide with general as well as detailed information about retrofit and high glide refrigerants in relation to application. As this theme will be present in refrigeration and air-conditioning business for a couple of years this collection has been done as general as possible. All examples shown should therefore be taken as neutral example just to discuss the technical aspects.

Danfoss offers a broad product portfolio for refrigerants with low global warming potential (low GWP). Please contact your respective Danfoss representative to get the newest information.

Talking retrofit it's only about existing systems that should be fitted with an alternative refrigerant. Reasons to think about retrofit are:

1. Refrigerant type is no longer allowed
2. Refrigerant type is no longer available
3. To replace the whole installation is too expensive

It should always be considered that a new system with a state of the art low GWP refrigerant should be more efficient and therefore have lower operating cost than an old retrofitted one.

1. Quick check before retrofit (Norbert Blatz)

Before starting to retrofit a system it needs to be verified if the system can be fitted with the refrigerant in scope. Maybe some additional changes need to be done.

2. Refrigerant retrofitting; Chemical compatibility of components (Rasmus Damgaard Poulsen)

As extension to the "Quick check" and more in detail of which scenarios are possible retrofitting a system and what it means for components and materials.

3. System retrofit procedure (Norbert Blatz, Thierry Legay)

Step by step guidelines of how to process a system retrofit. An example of a small system which can on larger scale be transferred to more complex systems.

4. Retrofitting systems with Glide refrigerants (Norbert Blatz, John Broughton)

Most of the refrigerants used for retrofit, but also designing a new system are refrigerant types which are blends and come along with a relative high temperature glide.

What that is and what it means to the system and application will be described in detail but also with as much as possible relation to practice.

1. Quick check before retrofit

By Norbert Blatz, Global Application Excellence Manager

Compressor:

- Can the compressor run with the new refrigerant?
- Check of how much the cooling capacity will change.
- Does the application envelope still fit? Check temperature and pressure limits.
- In most cases the oil charge need to be exchanged with new one.

Condenser:

- Check if the capacity will fit to the new compressor capacity. Refrigerants with glide require larger surface due to lower mean temperature difference. This may cause an increase of condensation temperature.

Evaporator:

- Check if the capacity respectively performance will still fit to the storage requirements in terms of humidity. Refrigerants with glide may cause higher de-humidification rate.

Valves:

- Solenoid valves and other type of valves with rubber gaskets must be fitted with new gaskets. Reason is that usually oil/refrigerant will enter the material can cause swelling. With the new oil / refrigerant the old contend will be washed out and the gasket will not be tighten anymore and leakage to the ambient will occur after a period of time.

- Thermostatic expansion valves or valves which have a thermostatic element charged for a specific refrigerant cannot just be used with a new refrigerant type. As first approach the pressure – temperature curve of both the old and new refrigerant can be compared. If the valve can be adjusted and the difference at the desired system temperature does not differ more than 3 K, a re-adjustment to the new condition might be possible. If any doubt, double check with your Danfoss staff.
- Other control valves, like pressure control valves, may require re-adjustment. Check if the setting range of the valve and max working pressure of the system is still ok with the new refrigerant.

Pipe work:

- Check dimensioning of pipework. The new refrigerant may have different density and enthalpy (heat transport) values. This result in different velocities and pressure drop keeping the existing pipework. A critical point can be suction line and oil return!

Controller:

- Check if the controller need adjustments. The setting of superheat controller need to be maintained with the new refrigerant type. Maybe also other temperature or pressure settings need to be adopted.

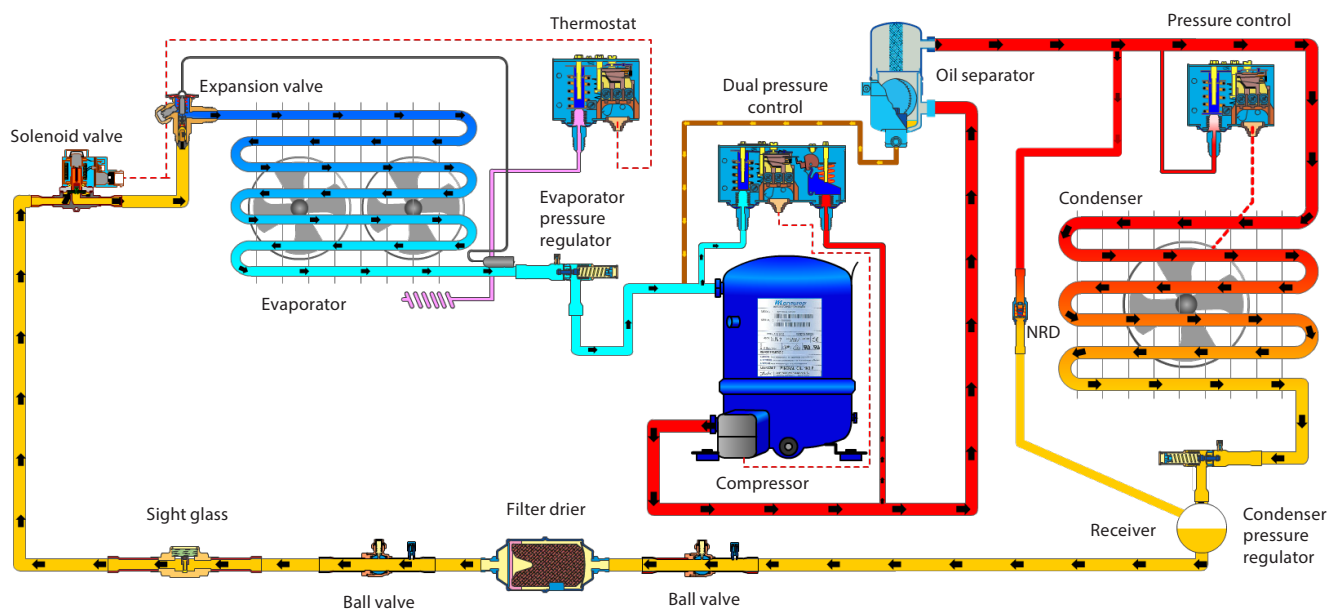

2. Refrigerant retrofitting; Chemical compatibility of components

By Rasmus Damgaard Poulsen, Specialist, Global Laboratory Technology, Ph.D. Chemistry

The retrofit of cooling systems is in this context defined as the change of refrigerant and/or oil in a current operating system. It is a well-known fact that the implications mainly concern the compatibility of seals leading to leakage or malfunction of the system as well as the setting of the individual systems (for example expansion devices and other rated sizes of components used in the system). This article focus on the material compatibility issues which may occur during a retrofit of components in cooling systems. Compressor related issues, capacity and efficiency changes due to new thermodynamic data or functionality changes such as superheat adjustments at expansion devices, miscibility with humidity is not handled.

The concern about the compatibility is that the change in chemistry when going from one refrigerant/oil mixture to another will cause major changes to the performance of seals leading to leakage or malfunction of functionality of Danfoss components. From a technical point of view the

risk concerns mainly volume changes and compression issues for regular non-dynamic seal, where also other properties such as hardness, tackiness, elongation, ability to work at max and min temperature amongst other parameters are also of concern.

The risk is well-known and manufacturers of both seals and retrofit refrigerants are currently stating that all seals should be replaced in case of retrofit. Also it is well-known that for many of the seals used in refrigeration systems, the various oil types may have different influence with respect to altering the properties of the sealing material. A general concern when doing retrofit is that the change may lead to particles and residues that before the retrofit were adhered to the system may separate under the new conditions. These may block or give unwanted mechanical issues in the retrofitted system.

When looking at retrofit there are three main cases, Retrofit type 1, 2 and 3 , which need to be addressed with respect to in-compatibility issues:

Retrofit type	Refrigerant type	Oil type	Properties change background	Risk assessment
1	HFC to HFC / HFO	POE to POE PVE to PVE	Both former and retrofit refrigerant have similar properties with respect to the chemical	Very low
2	HCFC to HFC / HFO	MO to MO AB to AB	The former and retrofit refrigerants have different properties with respect to the chemical	Minor
2	HCFC to HFC / HFO	MO to POE / PVE AB to POE / PVE	The former and retrofit refrigerants have different properties with respect to the chemical compatibility with the seals. The oil change may give different properties.	Major

Note: The risk assessment above is only valid if a full change of seals have been applied. Detailed assessment is written hereafter.

Note: Naming HydroChloroFluoroCarbon (HCFC); HydroFluoroCarbon (HFC); HydroFluoroOlefin (HFO), PolyOIEster (POE); PolyVinylEther (PVE); Mineral oil (MO); AlkylBenzen (AB)

Refrigerant retrofitting; Chemical compatibility of components (Cont.)

Retrofit type 1

Exchange of refrigerants with similar compatibility properties and oil remaining the same type

- The change of the refrigerant will not alter the properties of the sealing material leading to major risks.
- The retrofit type may be a HFC to HFC / HFO type while keeping the POE oil. It will cause very little concern regarding risks if the temperature and pressure specification are alike.
- Upon a change of seals the risk is low as all refrigerant is removed. Any oil still left in the system will react similar to new retrofit oil unless the old oil has been cracked or damaged in the old system.
- Risk of complications is very low, which is also backed up by historical data

Retrofit type 2

Exchange of refrigerants with different compatibility properties and oil remaining the same type

- The change of the refrigerant may cause issue with respect to degassing (crimp) or excessive swelling upon the retrofit.
- The retrofit type may be a HCFC to HFC / HFO type while keeping the type of MO oil. It will cause minor concern regarding risks if the temperature and pressure specification are alike.
- Of greatest concerns are current the usage of seals with high amount of softeners that may have been washed out by the initial refrigerant or the reverse situation with the retrofit refrigerant. The risk of malfunction or leakage lies in the ability of the retrofit refrigerant to act similar to the former refrigerant to maintain the overall system chemistry.
- Upon a change of seals the risk is low as all refrigerant is removed. Any oil still left in the system will react similar to new retrofit oil unless the old oil has been cracked or damaged in the old system.
- Risk of complications is minor, which is also backed up by historical data.

Retrofit type 3

Change of refrigerant and change of oil type, both having different properties

- The change will alter the properties of the sealing material leading to major risks.
- The retrofit type could be a HCFC to HFC / HFO type and changing the MO to POE oil. It will cause major concern regarding risks; and higher if the temperature and pressure specification are not alike.
- Upon a change of seals the risk is low concerning the refrigerant only; if all refrigerant is removed.
- The concern is the incompatibility when having two oils present in the system with different compatibility towards sealing materials. Consequently, even though the system chemistry may be validated for HFC / HFO refrigerant POE oil usage, the presence of a MO type may lead to other changes in the sealing material compatibility resulting in leakages or malfunction. In this matter also the TXV expansion as well as moisture indicator and eliminator needs to be addressed, as immiscible oil may end up altering the mechanical and chemical properties.
- If seals and refrigerant is changed according to the above; the major risk is the oil type change. If a 100 % change of oil is possible the risk will be as low as the Retrofit type 2. However, in reality it is most often not possible to change the entire oil package. Precautions such as improved oil return may lower the risk of an oil mixture circulating through the entire system; however the assurance of this is system specific and as such not known.
- Also, some retrofit refrigerants do contain some Hydrocarbons in-which the MO is miscible. From a theoretical point of view this should then make the transportation of the MO type oil in the system possible system.
- Risk of complications is major as there are many different scenarios that relates to the extend of the oil replacement percentage as well as the type of retrofit refrigerant. No historical data is known. Moreover, changes in system specifications such as temperature and pressure may heighten the risk.

3. System retrofit procedure

By Norbert Blatz and Thierry Legay, Global Application Excellence Manager

Step 1 - Controlling the operating parameters

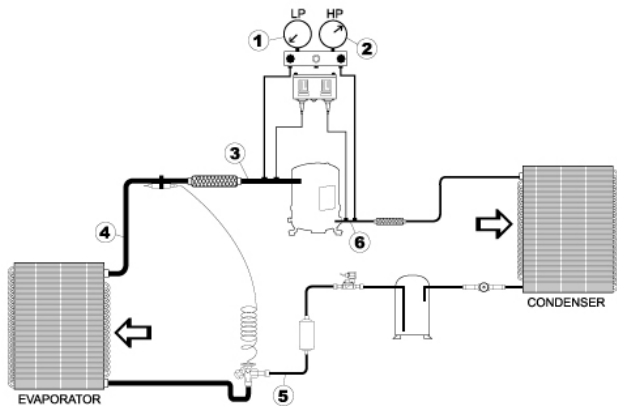

Measure:

1. Suction pressure at the compressor
2. Discharge pressure at the compressor

Measure:

3. Suction temperature at the compressor (i.e.: total superheat)
4. Suction temperature at the evaporator outlet (i.e.: evaporator superheat)
5. Liquid temperature at the expansion valve inlet (i.e.: liquid sub cooling)
6. Discharge temperature at the compressor

Measure:

7. Power supply voltage and current
8. Control the refrigerant flow to the evaporator on each distributor tube (carefully check for tubes blocked by dirt and sludge).

Step 2 - Removing the refrigerant charge

Refrigerant recovery equipment has to be used.



- Close the liquid receiver's shut off valve or any component of the liquid line suitable to be used for a pump-down.
- Let the system run until the low-pressure switch cut the compressor off.
- Switch the main circuit breaker off.
- Isolate (if possible) the compressor HP side from the system by closing the rotolock discharge valve.
- Remove the refrigerant from the HP side of the system through any connection or valve located on the liquid line.
- Once the HP side refrigerant has been transferred, into thereclaim bottle, open the insulating device on the LP side.
- Make a note of the weight of refrigerant mass reclaimed.

Important Remarks:

- Systems charged with flammable refrigerants (safety classes A2, A2L, A3) should be serviced and maintained following good refrigeration practice, with some changes to tools, equipment and procedures. Engineers working on flammable gas systems should be appropriately trained!
- Tools should be rated for a Zone 2 area use or have been suitably tested for use with flammable refrigerants.
- The work area must be well ventilated with no source of ignition within 3 m of the system. A dry powder or CO₂ fire extinguisher must be available at the location.
- Before opening the system, the flammable refrigerant must be removed completely from the system, and the system must be flushed with nitrogen.

System retrofit procedure (continued)

Step 3 - Compressor oil drain

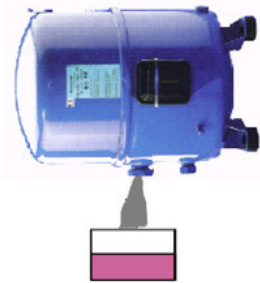

Danfoss Maneurop®
reciprocating compressors



Danfoss large scroll
compressors

Oil drain connection

- Open the suction port, or the sight glass port (when fitted).
- Move the compressor slowly to a horizontal position and recover the oil through the compressor suction connection port, or from the oil sight glass opening.
- Note: the large scroll compressor is equipped with an oil drain connection and can therefore be drained of its lubricant in a vertical position. In this case, pressurize the LP side of the compressor (using dry nitrogen).
- Pick an oil sample for analysis if needed (i.e. operational installation).
- Before re-installing the compressor, or replacing the sight glass, replace the gaskets by new ones (suction & discharge ports, sight glass gasket). Check the old lubricant for acid content using an acid test kit.
- Install a new filter drier. A burnout filter, like "DAS" or "DCR-DA" has to be used if the acid test is positive. The burnout filter has to be removed after a few days when the system is acid free.

Important:

Since a small amount of oil may remain in the system (pipes, heat exchanger, etc.) it cannot be removed by this process. To reduce the amount of old oil it is recommended to change to oil charge once again after some days running time.

Step 4 – Lubricant: filling in instructions

The following procedure describes how to add lubricant to compressors installed on a system.

1. Initial steps and equipment required



- Pump the low-pressure side of the compressor down to atmospheric pressure. Exercise care not to go into vacuum to prevent air and moisture ingress into the compressor during the filling in procedure.
- Use a new sealed lubricant can and a manual oil pump. The pump hose shall be sized for 1/4" flare fittings and include a valve depressor at its end, which will open the valve on the compressor schrader service port.
- The approved lubricant type is stamped on the compressor nameplate. Check that the oil can reference matches the type of lubricant on the compressor nameplate. Check that the oil can reference matches the type of lubricant on the compressor nameplate.

2. Pump and hose purging



- The hand pump (similar to the one shown) is inserted in the oil container – ensure the pump is clean – at the very last moment to keep container open to the atmosphere a minimum amount of time (use plug adaptor kit when available to further reduce lubricant exposure to the atmosphere).

System retrofit procedure (continued)

- With a few strokes of the pump bleed all the air from the pump and hose. Purging the pump is necessary to flush clean the hose of the moisture-saturated lubricant left inside from previous usage.
- Connect hose to the compressor schrader immediately after purging to avoid moisture contamination.

3. Pumping the lubricant in the compressor



- Pump in the estimated amount of lubricant or until the sight glass shows the level to be correct.

Note: when an excessive amount of lubricant has been lost from a compressor not fitted with a sight glass, the oil level cannot be measured or seen. The only way to ensure the correct charge is poured in, is to drain the compressor and recharge it with new lubricant.

In such a case, the compressor shall be removed from the installation.

Additional recommendations

- After adding oil, allow the compressor to run fully loaded for 20 minutes and re-check the level in the oil sight glass. This level should be between $\frac{1}{4}$ and $\frac{3}{4}$.
- Be careful not to add more oil than necessary. The following adverse conditions can occur if excessive oil is present:
 - Failure of valves and pistons or scroll involutes due to oil slugging
 - Excessive carry over of oil
 - Loss of evaporator performance due to oil level built-up in the low side of the system.

Step 5 - Vacuum pump down and dehydration procedure

When carrying out a retrofit, after changing the system components (e.g. filter drier, expansion valve, etc...) and re-installing the compressor, the refrigerating circuit must be thoroughly evacuated.

This section gives the best rules of practice when carrying out the vacuum dehydration of a system. The moisture content of a refrigeration circuit is quite difficult to measure. Therefore, following this procedure is the best way to reach a safe and acceptable moisture level before commissioning an installation.

Moisture obstructs the proper functioning of the compressor and the refrigeration system. Air and moisture reduce service life and increase condensing pressure. They also cause excessively high discharge pressure and temperature, which can destroy the lubricating properties of the oil.

Air and moisture also increase the risk of acid formation, giving rise to copper plating and motor insulation damage. All these phenomena can cause mechanical and electrical compressor failure. To eliminate these factors, a vacuum pump down according to the procedure below is recommended.

Procedure

Whenever possible (if shut-off valves are present), the compressor must be isolated from the system. It is essential to connect the vacuum pump to both the LP & HP side in order to avoid dead-ending parts of the system.

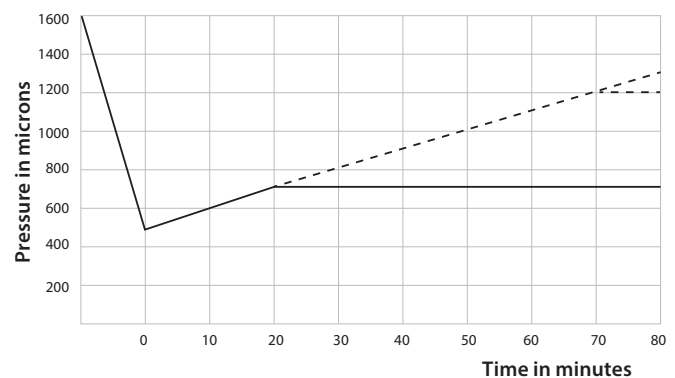

1. After leak detection,
2. Pull down the refrigeration circuit under a vacuum of 500 $\mu\text{m Hg}$ (0.67 mbar).
3. When a vacuum level of 500 $\mu\text{m Hg}$ is reached, the circuit must be isolated from the pump.
4. Wait for 30 min.
5. If the pressure rapidly increases, then the circuit is not leak tight. Locate and repair leaks. Restart from step 1.
6. If the pressure slowly increases, then the circuit contains moisture. Break the vacuum with nitrogen gas and repeat steps 2 - 3 - 4.

System retrofit procedure (continued)

Compressor fitted with shut off valves

7. Connect the compressor to the system by opening the valves.
8. Repeat 2 - 3 - 4 (and 5 or 6, if required)
9. Break the vacuum with nitrogen gas
10. Repeat 2 - 3 - 4 on the entire circuit

Compressor without shut off valves

7. Break the vacuum with nitrogen gas
8. Repeat 2 - 3 - 4 (and 5 or 6, if required)

A vacuum of 500 $\mu\text{m Hg}$ (0.67 mbar) should be reached and maintained for 4 hours. It will guarantee that the circuit is both tight and fully dehydrated. This pressure shall be measured at the refrigeration system, not at the vacuum pump gauge.

Vacuum pump

A two-stage vacuum pump with gas ballast (0.04 mbar standing vacuum) shall be used with a capacity consistent with the system volume. It is recommended to use connection lines with a large diameter and to connect these to the shut off valves, not to the compressor Schrader connection. This is to avoid excessive pressure losses.

Moisture level

At the time of commissioning, system moisture content may be up to 100 ppm. During operation, the filter drier must reduce this to a level between 20 and 50 ppm.

Points to remember

- During the initial system/circuit evacuation, lowering the pressure below 500 $\mu\text{m Hg}$ introduces the risk of freezing the moisture present in the system (liquid moisture trapped in small pockets will turn into ice and not evaporate). The low vacuum achieved can be misinterpreted as a moisture free system whereas, in fact, ice is still present. Such a risk becomes major when utilizing a relatively large vacuum pump on a small volume circuit. A single vacuum pump down evacuation at 0.33 mbar (250 $\mu\text{m Hg}$) will not guarantee a sufficiently low moisture level.
- A low ambient temperature around the equipment impedes moisture removal – below 10°C ambient.
- Take counter measures and energize the compressor's crankcase heater.
- Adopting the above procedure is even more important with HFC and polyolester oil than it has traditionally been with HCFC (R22) or CFC and mineral oil.

Warning

Do not use a megohmmeter or apply power to the compressor while it is under vacuum. This may cause motor winding damage. Never run the compressor under vacuum as it may cause compressor motor burnout.

Step 6 - Refrigerant charging

Zeotropic and "near-azeotropic" refrigerant mixtures such as R407C and R404A must always be charged in liquid phase. For the initial charge, the compressor must be stopped and service valves must be closed.

Charge refrigerant as close to the nominal system charge as possible before starting the compressor.

Then, slowly add refrigerant in liquid phase on the low-pressure side, as far away as possible from the running compressor.

Warning

- When a liquid line solenoid valve is used, the vacuum on the low-pressure side must be broken before applying power to the system.
- The amount of refrigerant charge must be suitable for both winter and summer operation. Refer to the section "Liquid refrigerant control and charge limits" of the compressor application guidelines brochures for information about refrigerant charge limits.

Step 7 - Controlling after start-up

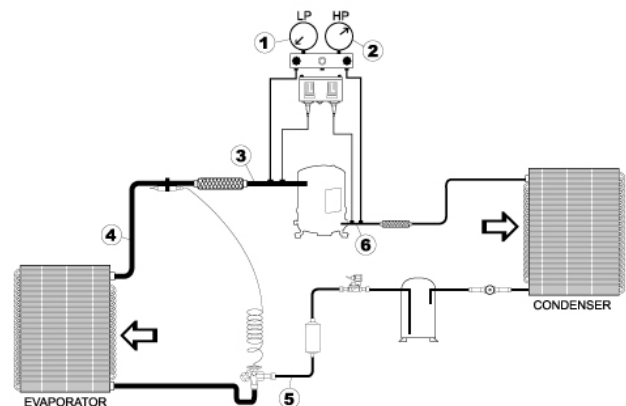

Measure and note:

1. Suction pressure at the compressor
2. Discharge pressure at the compressor
3. Suction temperature at the compressor (i.e.: total superheat)
4. Suction temperature at the evaporator outlet (i.e.: evaporator superheat)
5. Liquid temperature at the expansion valve inlet (i.e.: liquid sub cooling)
6. Discharge temperature at the compressor outlet

Check whether measured data is within expected / acceptable range and within application envelope of components in the system

There are some special aspects when using refrigerants with a high temperature glide. The effects and how to deal with it is theme of the next chapter:

4. Retrofitting systems with Glide Refrigerants

By Norbert Blatz, Global Application Excellence Manager and John Broughton, Global Application Expert, Commercial Refrigeration

As a consequence of the F-gas regulation on lowering GWP of refrigerant a number of new synthetic refrigerant types are or will be on the market. Most of them are zeotrope mixtures with a significant temperature glide.

In order to visualize the differences to azeotropic (non-glide) refrigerants, log(p) / h diagram and p / t diagram style has been chosen.

All different kind of states at different conditions can be found in a log(p) / h diagram. The x-axis is about specific enthalpy while the y-axis shows pressure, usually in logarithmic scale. From left to right side it goes from pure liquid crossing the bubble point, where evaporation process starts, entering the saturation area. Across the saturation phase both states, liquid and vapor, are present. The more energy added the more liquid evaporates until dew point where all liquid has changed state to vapor. Crossing dew point the vapor will become superheated.

The value of superheat is measured as temperature difference between dew point temperature and superheated vapor temperature at the same pressure e.g. at the outlet of a dry expansion evaporator. As an example the application range of "Range N" TXV from Danfoss has been added.

Diagram 1

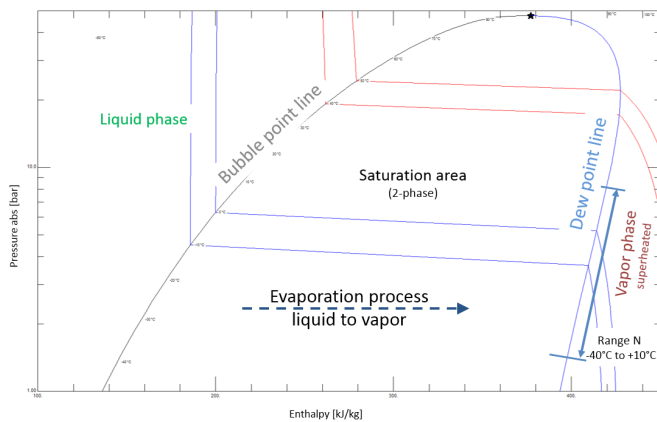

Within the saturation area the temperature depends directly on the pressure. In case of pure refrigerants (no mixtures e.g. R134a) and azeotrope mixtures, the temperature will be the same through the whole evaporation process. For mixtures with glide = zeotrope mixtures, the temperature changes significantly during the evaporating or condensing process however the pressure remains constant.

This temperature glide is caused, very simplified, due to the refrigerant with the lowest evaporation temperature will evaporate first while the refrigerant with the highest evaporating temperature will evaporate last. To visualize effect of glide, a standard dry expansion circuit is drawn into a simplified log (p) / h diagram. Temperature difference at heat exchanger shall be 10 K both, to the ambient and to cold room temperature.

Example non-glide refrigerant, azeotrope mixture, R507A: p_c = condensation pressure and p_e = evaporation pressure.

Diagram 2

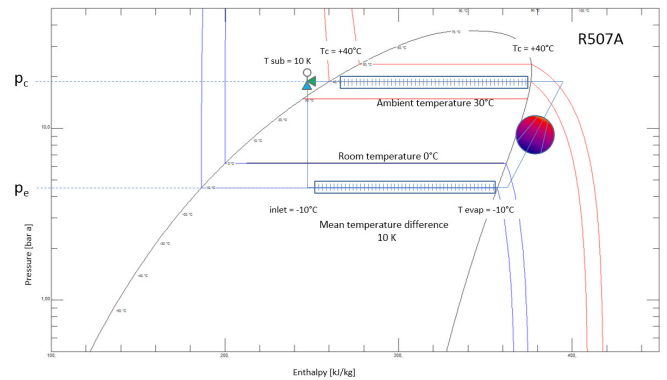

The same system, but now with zeotropic refrigerant R407F: To end up with 10 K temperature difference the evaporation temperature changes from -12.3 °C at the inlet to -8 °C dew point.

Diagram 3

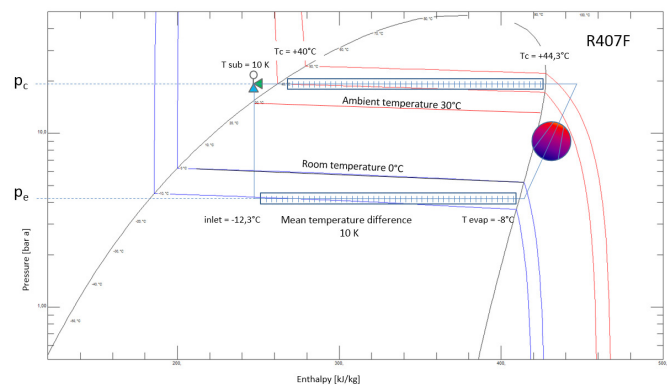

The change in evaporation temperature and its consequences for the heat exchanger and expansion device will be discussed in the next chapter.

Retrofitting systems with Glide Refrigerants (continued)

The impact to the application using refrigerant with high glide.

Due to the temperature change the temperature difference between air and heat exchanger will change too and should be taken into account while sizing the heat exchanger.

Condenser:

The mean temperature difference between air and condenser will be lower and require a larger condenser. Doing retrofit, it may cause an increase of condensation temperature if the compressor will have the same capacity as before.

Evaporator:

The mean temperature will increase and gives a positive impact in terms of capacity. But there are two critical aspect to take care about – the expansion device and change in dehumidification rate.

First a little bit about relation between superheat and heat exchanger capacity.

Superheat control:

The capacity of a fin & tube evaporator is defined based on air inlet temperature, DT1 and superheat value. DT1 has been specified as the temperature difference between air inlet and dew point evaporation temperature. E.g. air inlet = 0 °C, dew point evaporating temperature = -10 °C → DT1 = 10 K.

Diagram 4

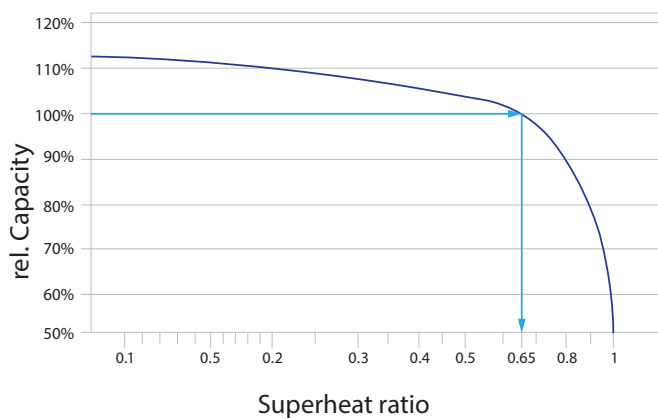

To get 100% evaporator capacity, target superheat is defined as DT1 x superheat ratio: 10 K x 0.65 = 6.5 K. From controls point of view a value of 0.65 is nearly the optimum and is specified by the standard EN 328 as target value for air coolers. Diagram 4 visualize that already small increase (higher SH) of this value cause a huge loss in using the surface of the evaporator.

On other hand a reduction in superheat will cause a relative small increase of capacity. Comparing evaporator superheat values of diagram 2 and 3 it shows different values. The evaporator mean temperature difference of diagram 2 and 3 is the same. But due to the glide with R407F in diagram 3, the required superheat value is lower. The reason for this is that dew point evaporating temperature with -8.1 °C is 2 K higher than R507A in diagram 2. DT1 = 0 °C - (-8.1 °C) = 8.1 K. Therefore target superheat = 8.1 K x 0.65 = 5.3 K.

High glide refrigerants and expansion valves

Expansion devices are using pressure and temperature to control the level of superheat at the outlet of the evaporator. For superheat control the dew point line (100% evaporated) is the only valid reference. The thermostatic element of the expansion valve is charged with a medium which ensures nearly the same temperature difference over a wide range (e.g. Danfoss Range N charge: -40 °C to +10 °C). Therefore with reference to the dew point the superheat can be determined.

Diagram 2, R507A for example need a superheat value of 6.5 K to utilize the evaporator by 100%. This is based on 10 K mean temperature difference.

Diagram 2, detail

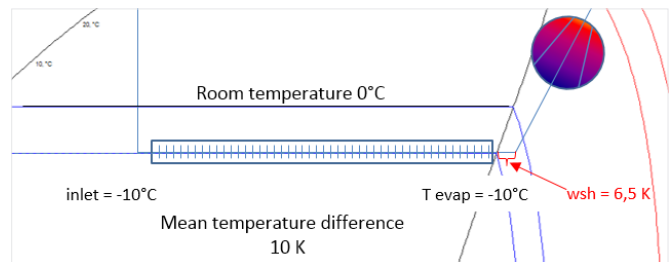

Retrofitting systems with Glide Refrigerants (continued)

Why superheat of a TXV may need to be re-adjusted?

1. Because of glide:

Diagram 3, due to the impact of glide with R407F the dew point temperature is about -8.1 °C and the same evaporator requires superheat setting of 5.3 K to utilize 100% capacity also at 10 K mean temperature difference.

Diagram 3, detail

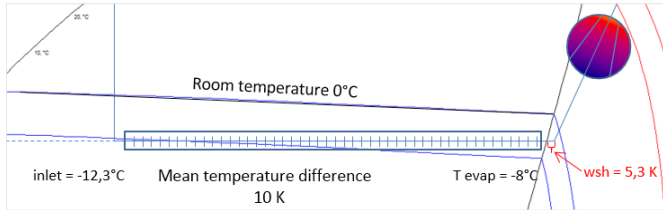

2. Doing retrofit a TXV with the correct charge may not be available:

Here a dew curve like you see at Diagram 1, but converted into well-known pressure over temperature:

Diagram 5

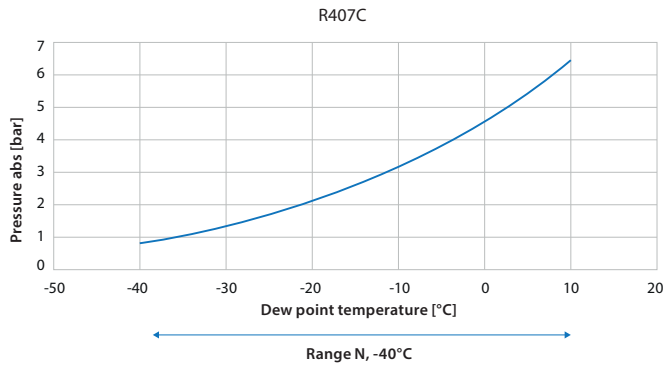

In order to increase required bulb temperature (superheated) to open the valve, a spring is added to work against sensor pressure: Sensor pressure + Spring "pressure" = Superheat

Diagram 6

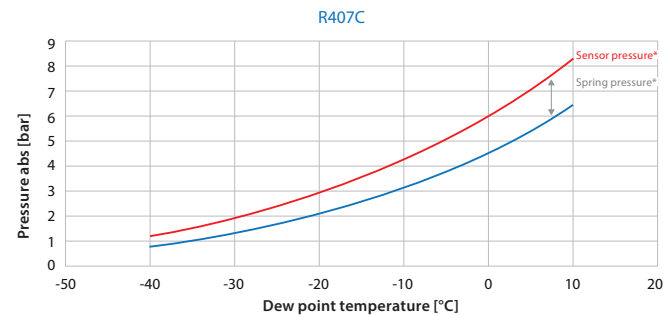

*Simplified to illustrate principle

Retrofitting with R407F the R407C charge + spring force/pressure will cause a too high superheat value. Therefore the spring force need to be reduced: This is done by turning the SH setting screw anti-clockwise.

Diagram 7

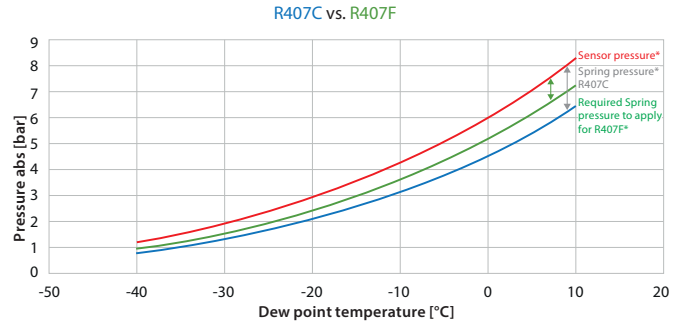

*Simplified to illustrate principle

Forces at a valve and how to reset static superheat

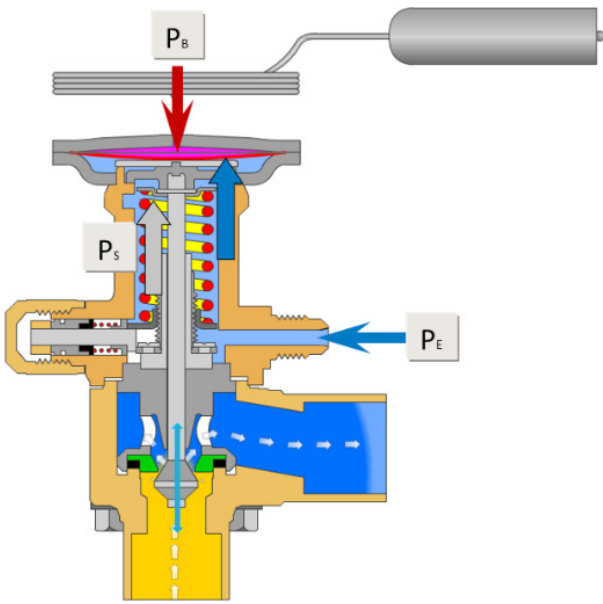

Sensor pressure P_B need to overcome Evaporation pressure P_E + Spring pressure P_s .
 Reducing spring pressure by adjusting the SH setting, can adopt the valve to a refrigerant it is basically not made for.

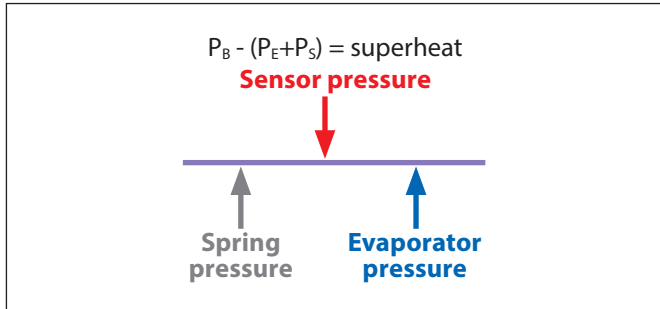

TE 5~55 superheat

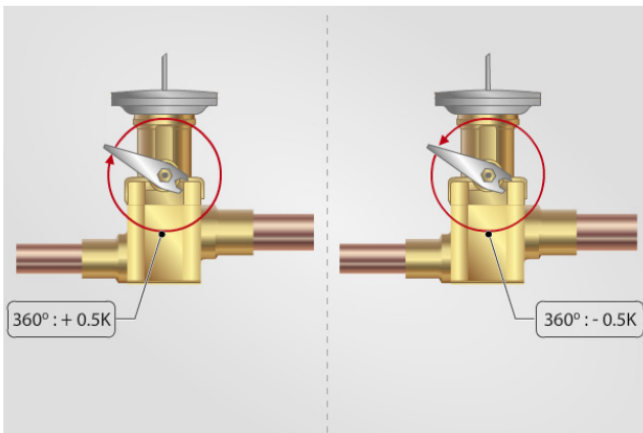

Attention! If the correction is more than maybe 3 K the quality of control may become worse. It is recommended to choose another charge type that is closer to the target value.

Example:

Static superheat $SS = 4 \text{ K} / 7.2 \text{ }^\circ\text{F}$ (factory setting)

Opening superheat $OS = 4 \text{ K} / 7.2 \text{ }^\circ\text{F}$

The opening superheat is 4 K, i.e. from the point the valve begins to open up to nominal capacity. Opening superheat is determined by the design and cannot be changed.

Total superheat $SH = SS + OS$

$$SH = 4 + 4 = 8 \text{ K} / 14.4 \text{ }^\circ\text{F}$$

Total superheat SH can be altered by changing SS (by using the setting spindle)

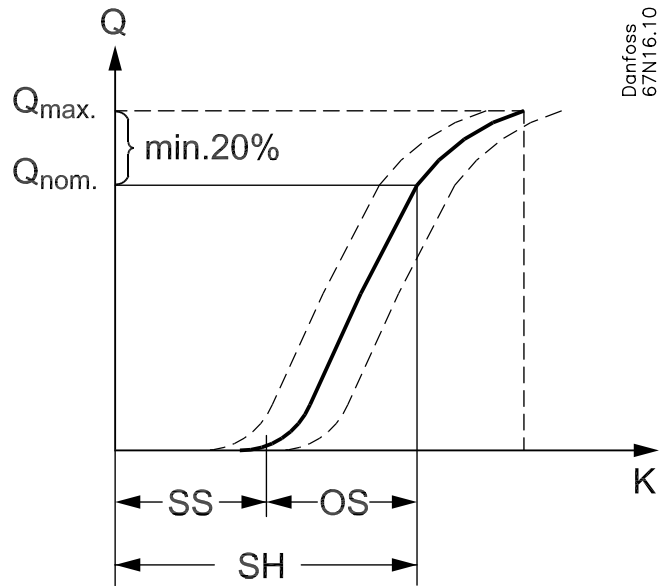

Evaporator performance using glide refrigerants and effect to application

Due to the glide, the temperature at parts of the evaporator surface will have a low temperature and can potentially increase dehumidification rate.

Let's look at the initial example values: (see Diagram 2)

Cold room, R507A, room conditions 0 °C, 80% rel.H, mean temperature difference 10 K.

Cooling capacity may be 10 kW.

A ceiling mounted type, 32.7 m² surface, 2 fans with 6280 m³/h has been selected.

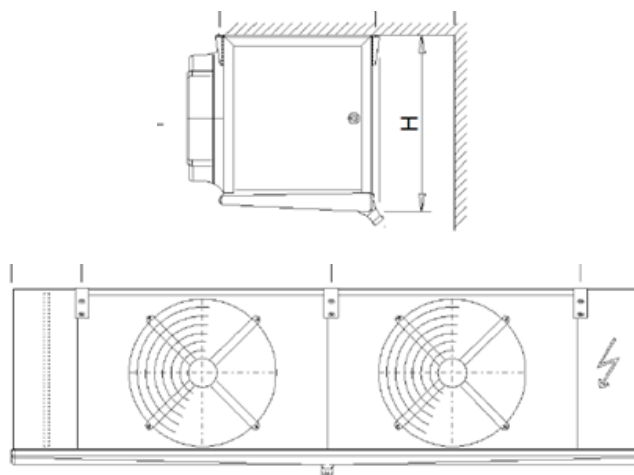

Detailed results

R507A	Capacity	Δt_m	DT1	T evap dew	Wsh	Run time
	10.1 kW	10 K	10 K	-10 °C	6.5 K	18 h/d
Evaporator:	2 fans / 32.7 m ²					
Air in:	0 °C	80% rel.H				
Air out:	-3.8 °C	95% rel.H				
Air flow:	6280 m ³ /h					
De-humidification	47.75 kg/d					

Retrofit with R407F

First step: The superheat setting will be the same as before: 6.5 K

Mean temperature difference of 12 K lead to increased capacity of 12.5 kW and cause a shorter running time. A negative point is the de-humidification rate which increased a lot. This is can be bad for un-packed fresh goods.

R407F	Capacity	Δt_m	DT1	T evap dew	Wsh	Run time
	12.5 kW	12 K	10 K	-10 °C	6.5 K	14.3 h/d
Evaporator:	2 fans / 32.7 m ²					
Air in:	0 °C	80% rel.H				
Air out:	-4.7 °C	95% rel.H				
Air flow:	6280 m ³ /h					
De-humidification	60.96 kg/d					

Second step: re-adjust the expansion valve to a superheat value of 5.3 K.

The superheat has been reduced to 5.3 K and the dew point evaporation temperature has been increased to -8.1 °C in order to get a temperature difference of 10 K. (see also Diagram 3)

R407F	Capacity	Δt_m	DT1	T evap dew	Wsh	Run time
	10.8 kW	10 K	8.1 K	-8.1 °C	5.3 K	16.6 h/d
Evaporator:	2 fans / 32.7 m ²					
Air in:	0°C	80% rel.H				
Air out:	-4.1 °C	95% rel.H				
Air flow:	6280 m ³ /h					
De-humidification	53.32 kg/d					

Important remark:

As these results show, an application where de-humidification is a critical parameter, the mean temperature difference should be lower than with single fluid or azeotrope mixture refrigerants.

Special effects:

It has been recognized, in some larger low temperature applications using high glide refrigerant, that liquid refrigerant was suffered to the compressor. The opposite of the above description was necessary to do. The superheat setting needed to be increased in order to protect the compressor. Low or non-glide refrigerants will not show these kind of effects in low temperature applications.

Summary:

Components for high glide refrigerants need to be sized and selected based on mean temperature difference. Already because of glide it can be necessary to re-adjust SH setting.

Using a refrigerant which works for one temperature level doesn't necessarily work also for another temperature level in the same way (e.g. air conditioning versus low temperature).

Each mechanical expansion valve has its performance optimised for use with a specific refrigerant. Using another refrigerant means the valve will not operate in exactly the same way or with the same level of control.

If you want to reduce risk of system issues and maintain the best stable system control, an adapted new thermostatic expansion valve or an EEV could be a good option for this. An EEV also offers greater flexibility in design later if the superheat controller can manage the refrigerant chosen. Danfoss always upgrades the controllers to available state of the art low GWP refrigerants.

Remark:

Refrigerants and conditions shown in this document will not vote for one or another refrigerant or conditions! Purpose of this paper is to discuss physical aspects and influence to components and system design on a neutral basis.

The suitability of a Danfoss expansion valve can be found using the Low GWP tool below.

<http://refrigerationandairconditioning.danfoss.com/support-center/apps-and-software/low-gwp-tool/>

See also:ASERCOM, Refrigerant Glide and Effect on Performances Declaration (<http://asercom.org/guides>)