



# Automatic balancing

**ASV-PV DN 50-100 (3 gen)**

## Description

ASV balancing valves are used for dynamic hydronic balance in heating and cooling systems. One of the major challenges in heating and cooling systems is a lack of good hydronic balancing, caused by differential pressure, which is changing constantly and unpredictably in the system. This often results in complaints about poor indoor comfort, noise and high energy bills. ASV automatic balancing valves ensure an optimal pressure differential for control valves as well as the correct flow within the individual risers at all times. The ASV automatically creates an optimal hydronic balance within the installation, whether under full or partial load. This balance is never disrupted.

## Features & benefits

- Flow limitation
  - By using combination of pressure controller ASV and settable terminal's unit valve, flow limitation is established. Flow limitation for each terminal unit prevents underflows on distant units and overflows on others this allows efficient pumping.
- Lower noise emission
  - Differential pressure limitation provides the pressure over the control valve not to increase at partial loads thus noise emission will be lower. (This is the reason why DIN 18380 requires control of differential pressure by partial load.)
- No balancing method needed
  - Flow limitation is achieved by adjusting each hydronic loop separately without influencing others, which consequently results in one time adjusting process. No special balancing method is needed so commissioning cost can be saved.
- Control valve authority
  - Controlling differential pressure over the control valve means that authority is high – which allows an accurate and stable control as well as energy saving.
- Zone balancing
  - By installing the ASV sets you can divide the piping system in pressure independent zones. This allows a gradual connection of zones to the main in new constructions or at renovation without using an additional balancing method. There is no need to perform a new commissioning every time the system is changed because the hydronic balance is done automatically.

## Applications

ASV valves DN 50 is supplied with external thread only. Threaded or weld tail pieces can be supplied as an accessory.

Dimensions DN 65-100 are supplied as flanged valves. ASV balancing valves have integrated service functions such as shut-off. ASV-PV can be equipped with plug for flow measuring. In that case measuring plugs need to be ordered separately and mounted on the valve as follows:

- on top of drain connection (DN 50),
- on the flange connection before the valve is filled with water (DN 65-100).

ASV-PV valves are to be mounted in return pipe, in combination with partner valves mounted in flow pipe. As a partner valve MSV-F2 is recommended.

---

There are two basic configurations when using ASV partner valves (MSV-F2):

- partner valve outside the control loop (Fig. 1). Recommended configuration: it results in best performance since whole controlled pressure range is available to the riser. Flow limitation is done on each terminal unit in the riser.

MSV-F2, by connecting impulse tube to down-flow test plug.

- partner valve inside control loop (Fig. 2). Offers flow limitation on the riser however part of the controlled pressure range is used by pressure drop on partner valve ( $\Delta p_i$ ). It is recommended when flow limitation on each terminal units is not possible.

MSV-F2, by connecting impulse tube to up-flow test plug.

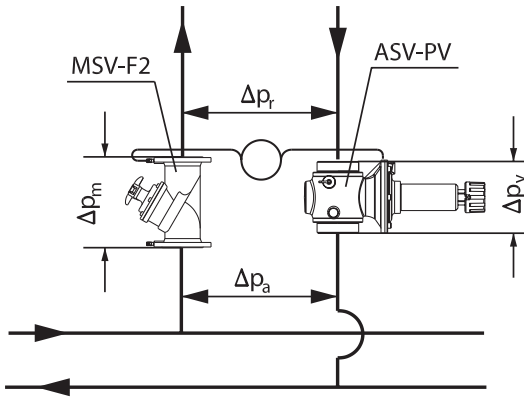

Fig. 1 Setting of  $ASV-PV = \Delta p_{riser}$

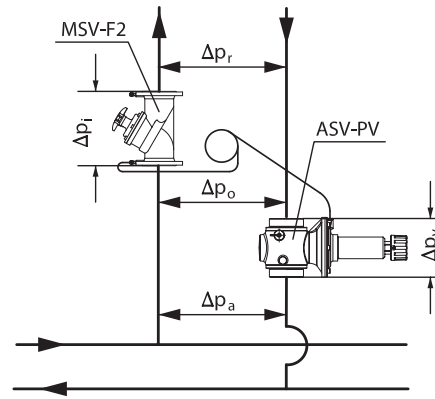

Fig. 2 Setting of  $ASV-PV = \Delta p_{riser} + \Delta p_i$

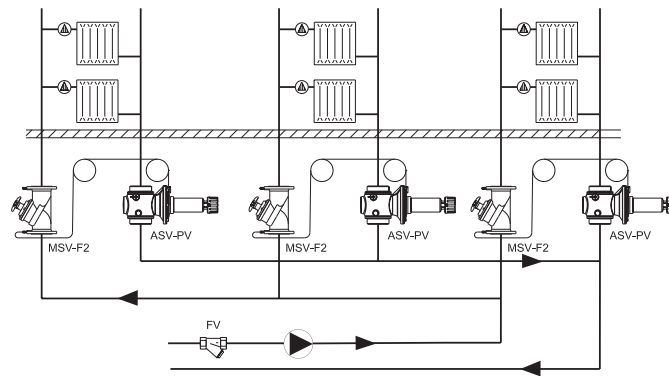

Fig. 3 ASV in riser / typical heating application (general example)

ASV valves are to be used in heating systems to control the differential pressure in risers. To limit the flow for every radiator, the thermostatic radiator valve with pre-setting facilities (feature) is used together with a constant pressure provided by the ASV, thus providing balanced heat distribution. Controlling differential pressure over the riser means also that the valve authority over the thermostatic radiator valves is high – which allows an accurate and stable temperature control and saves energy.

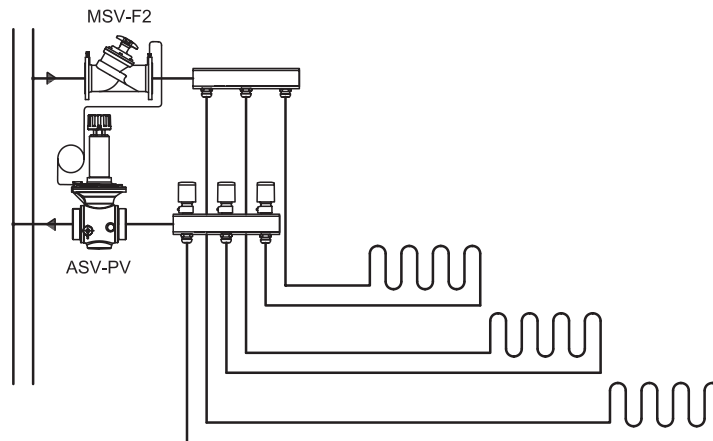

Fig. 4 ASV in manifold for floor heating system

ASV valves are to be used in floor heating systems. To limit the flow for every loop valves with an integrated flow limiting or presetting function should be used together with a constant pressure provided by an ASV-PV valve.

ASV-PV valves can control the differential pressure in several ranges if different pressure is needed.

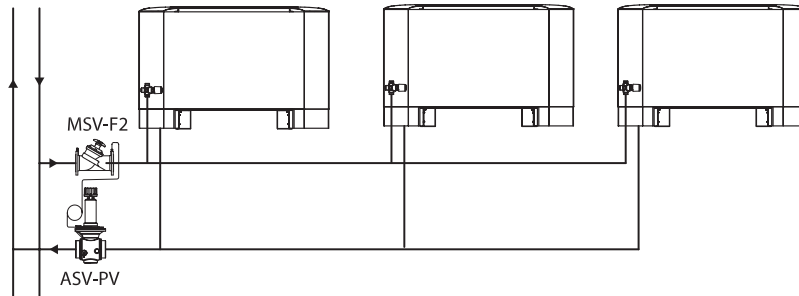

Fig. 5 ASV with fan coil

The ASV valves are to be used in systems with fan coils, induction devices and air-heaters to secure an automatic hydronic balance by the means of differential pressure control in branches or at every coil.

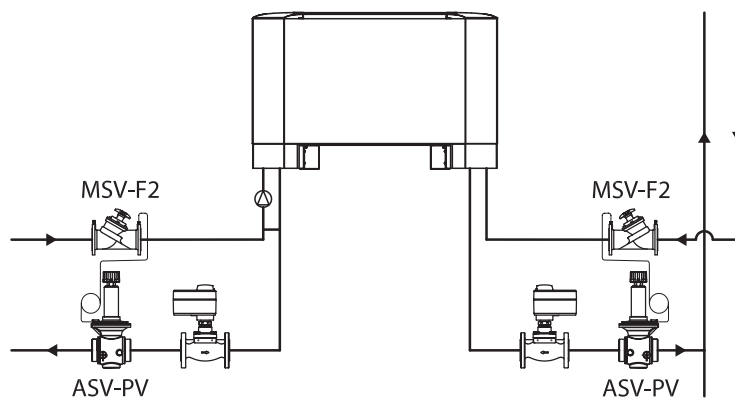



Fig. 6 ASV with air handling unit

The ASV valves are to be used in air handling units to secure an automatic hydronic balance by the means of differential pressure control at every unit.

## Ordering

### Product code numbers

**ASV-PV** balancing valve, inclusive in the box: 2.5 m impulse tube (G 1/16 A) drain connection (G 3/4 A) and adapter **003L8151**

Type	DN	$k_{vs}$ (m <sup>3</sup> /h)	Connection		$\Delta p$ setting range (kPa)	Code No.	Only for Danish market VVS-nr.
	50	20	External thread ISO 228/1	G 2 ½	5-25	<b>003Z0611</b>	40 6854.112
					20-40	<b>003Z0621</b>	40 6854.212
					35-75	<b>003Z0631</b>	40 6854.312
					60-100	<b>003Z0641</b>	40 6854.412

**ASV-PV** balancing valve, inclusive in the box: 2.5 m impulse tube (G 1/16 A), adapter ASV large **003Z0691** and **003L8151**

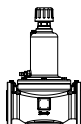
Type	DN	$k_{vs}$ (m <sup>3</sup> /h)	Connection	$\Delta p$ setting range (kPa)	Code No.	Only for Danish market VVS-nr.
	65	48	Flange EN 1092-2	20-40	<b>003Z0623</b>	40 6854.213
	80	63			<b>003Z0624</b>	40 6854.214
	100	76.0			<b>003Z0625</b>	40 6854.216
	65	48		35-75	<b>003Z0633</b>	40 6854.313
	80	63			<b>003Z0634</b>	40 6854.314
	100	76.0			<b>003Z0635</b>	40 6854.316
	65	48		60-100	<b>003Z0643</b>	40 6854.413
	80	63			<b>003Z0644</b>	40 6854.414
	100	76.0			<b>003Z0645</b>	40 6854.416

**MSV-F2** Partner valve with shut-off, flow limitation and test plugs <sup>1)</sup>

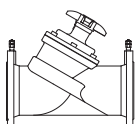
Type	DN	$k_{vs}$ (m <sup>3</sup> /h)	$T_{max.}$ (°C)	DN20 (bar)	Code No.	Only for Danish market VVS-nr.
	15	3.1	130	16	<b>003Z1085</b>	-
	20	6.3			<b>003Z1086</b>	
	25	9.0			<b>003Z1087</b>	
	32	15.5			<b>003Z1088</b>	
	40	32.3			<b>003Z1089</b>	
	50	53.8			<b>003Z1061</b>	40 6946.012
	65	93.4			<b>003Z1062</b>	40 6946.013
	80	122.3			<b>003Z1063</b>	40 6946.014
	100	200.0			<b>003Z1064</b>	40 6946.016

<sup>1)</sup> For more information see MSV-F2 datasheet

## Accessories code numbers

Description	Comments/connection	Code No.	Only for Danish market VVS-nr.
Shut off knob for MSV-F2	DN 50	<b>003Z0179</b>	-
	DN 65-100	<b>003Z0180</b>	
Differential pressure measuring connector	For drain connection	<b>003L8143</b>	40 6944.943
Impulse tube, with O-rings	1.5 m	<b>003L8152</b>	40 6859.852
	2.5 m	<b>003Z0690</b>	-
	5 m	<b>003L8153</b>	40 6859.853
Plastic impulse tube with connectors and adapters	For making set of 10 pieces <sup>4)</sup>	<b>003Z0689</b>	-
Adapter large ASV <sup>1)</sup>	G ¼ - R ¼; G ¼	<b>003Z0691</b>	40 6859.861
Plug for connecting impulse tube <sup>2)</sup>	G ¼ - R ¼	<b>003L8151</b>	40 6859.851
O-ring for impulse tube <sup>3)</sup>	2.90 × 1.78	<b>003L8175</b>	40 6859.975

<sup>1)</sup> Recommended for use with MSV-F2, connected to measuring hole, it allows connection of impulse tube from ASV while retaining measurement functionality.

<sup>2)</sup> Recommended for use with MSV-F2, connected to measuring hole. Can also be used for connecting impulse tube directly on the pipe.

<sup>3)</sup> Set of 10 pieces.

<sup>4)</sup> Total 15 meter of impulse tube.

### Fitting

For valves with external thread Danfoss offers threaded or welded tailpieces as accessory.

Comment	to pipe	to valve	Code No.	Only for Danish market VVS-nr.
Tailpiece threaded (1 pcs.)	R2	DN 50 (2 ¼")	<b>003Z0274</b>	-
		DN 50 (2 ½")	<b>003Z0278</b>	40 6846.812
Tailpiece welding (1 pcs.)	DN 50	DN 50 (2 ¼")	<b>003Z0272</b>	-
		DN 50 (2 ½")	<b>003Z0276</b>	

## Product details

### General data

#### Technical data

Type		ASV-PV	MSV-F2 <sup>1)</sup>
Nominal diameter	DN	50-100	
Max. pressure	bar	16 (PN 16)	
Test pressure		25	
Differential pressure over the valve	kPa	10-250 <sup>2)</sup>	10-150
Temperature	°C	-10 ... 120	-10 ... 130

<sup>1)</sup> For more information see MSV-F2 datasheet.

<sup>2)</sup> Please note that the maximum admissible differential pressure across the valve 250 kPa should also not be exceeded at partial load.

**Sizing**

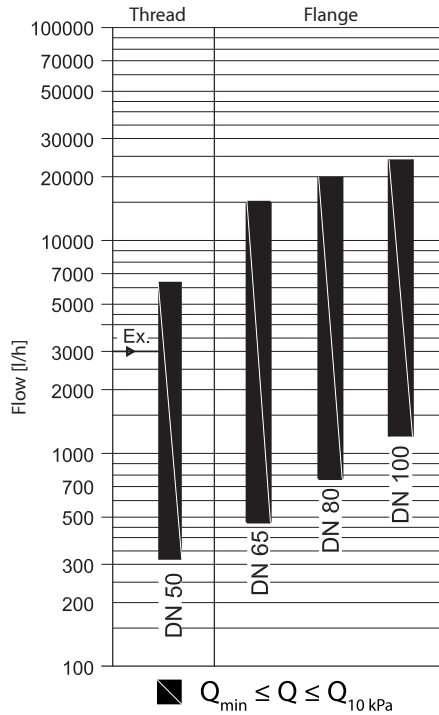

Fig. 7: Column diagram for sizing ASV valves at  $\Delta p_v = 10 \text{ kPa}$ . For different  $\Delta p_v$  values use diagram A in Appendix.

We recommend to size the diameter of ASV-PV valves by using the figure. Maximum flow rates are based on 10 kPa differential pressure over the valve which allows efficient pumping and saves energy.

After ASV-PV valves have been sized the same dimension of partner valve MSV-F2 valve should be selected.

**Example:**

Given:

Pipe flow 3000 l/h, pipes DN 50

**Solution:**

Horizontal line intersects the column for the valve DN 50 which can therefore be selected as required size.

For detailed sizing see examples. For different  $\Delta p_v$  (differential pressure over the valve) see diagrams in Appendix A.

**Connection between valves size and pipe size**

$K_v$  values per particular dimension were designed to cover low range according to VDI 2073 with water velocity of up 0.8 m/s, at differential pressure of 10 kPa over the valve. As long as the water velocity in the pipe is between 0.3 and 0.8 m/s dimension of the valve should be equal to pipe dimension.

This rule is derived out of the fact that  $K_v$  values per particular dimension were designed to cover flow range according to VDI 2073 at differential pressure of 10 kPa over the valve.

## Sizing-design examples

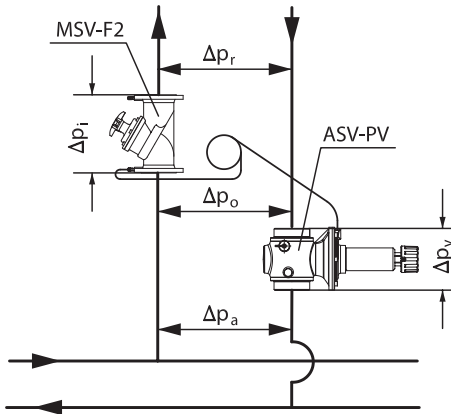

$$\Delta p_a = \Delta p_m + \Delta p_r + \Delta p_v$$

$\Delta p_v$  Pressure drop across ASV-PV valve

$\Delta p_i$  Pressure drop across MSV-F2

$\Delta p_o$  Pressure drop across the riser including MSV-F2

$\Delta p_a$  Pressure drop across the riser

$\Delta p_r$  Pressure drop in the riser excluding MSV-F2

### 1. Example (AHU - air handling unit)

Given:

Desired flow for the riser ( $Q$ ): 15 m<sup>3</sup>/h

Minimal available pressure for that riser ( $\Delta p_a$ ): 100 kPa

Estimated pressure drop over the riser at the desired flow ( $\Delta p_o$ ): 40 kPa

Wanted:

- Valve type
- Valve size

Selection and sizing of automatic balancing valves for air handling unit. The customer have choosen ASV-PV with partner valve MSV-F2 inside the control loop is choosen. Since the calculated pressure drop over the riser is 40 kPa ASV-PV with setting range between 35-75 kPa is selected. The minimal available pressure for the riser is 100 kPa and pressure drop across ASV-PV ( $\Delta p_v$ ) will following be 60 kPa

$$\Delta p_v = \Delta p_a - \Delta p_o = 100 - 40 = 60 \text{ kPa}$$

$$k_v = \frac{Q}{\sqrt{\Delta p_v}} = \frac{15}{\sqrt{0.6}} = 19.36 \text{ m}^3/\text{h}$$

Based on this calculation ASV-PV DN 65 is selected with partner valve MSV-F2 also DN65.

Set the valve to 40 kPa, see figure 11 (40kPa = 35 turns).

Selection can also be made by reading from diagram Appendix A. fig A

### 2. Example (continued AHU - air handling unit)

Given:

Correcting the flow with the differential pressure setting.

Desired flow for the riser ( $Q_2$ ): 15 m<sup>3</sup>/h

Measured flow for the riser ( $Q_1$ ): 18 m<sup>3</sup>/h

Estimated pressure drop over the riser at desired flow ( $\Delta p_o$ ): 40 kPa

Required:

Correct flow to 15 m<sup>3</sup>/h for the riser.

Solution:

Measuring the flow show that it is higher then what is desired for the riser, this could be caused by the real pressure drop over the riser is higher than the estimated 40 kPa, following setting on the ASV-PV valve can be adjusted to limit the flow.

$$p_2 = p_1 \times \left(\frac{Q_2}{Q_1}\right)^2 = 40 \times \left(\frac{15}{18}\right)^2 = 28 \text{ kPa}$$

If we decrease the setting from 40 to 28 kPa flow will be decreased to 15 m<sup>3</sup>/h.

Alternatively, flow limitation inside the loop can also be done with MSV-F2 by adjusting the setting of the valve.

### Appendix A-Sizing diagram

#### Sizing diagram ASV-PV DN 50-100

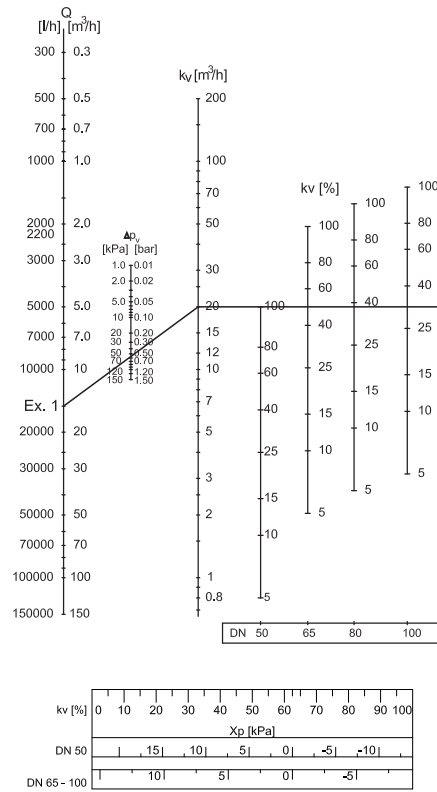

#### Sizing diagram MSV-F2 DN 50-100

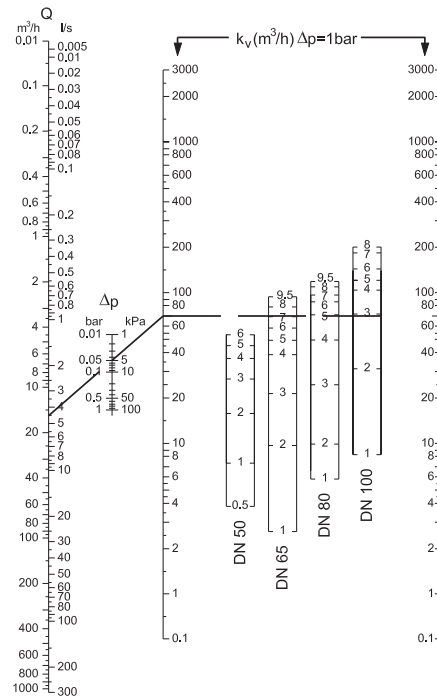

## Appendix B MSV-F Flow diagrams

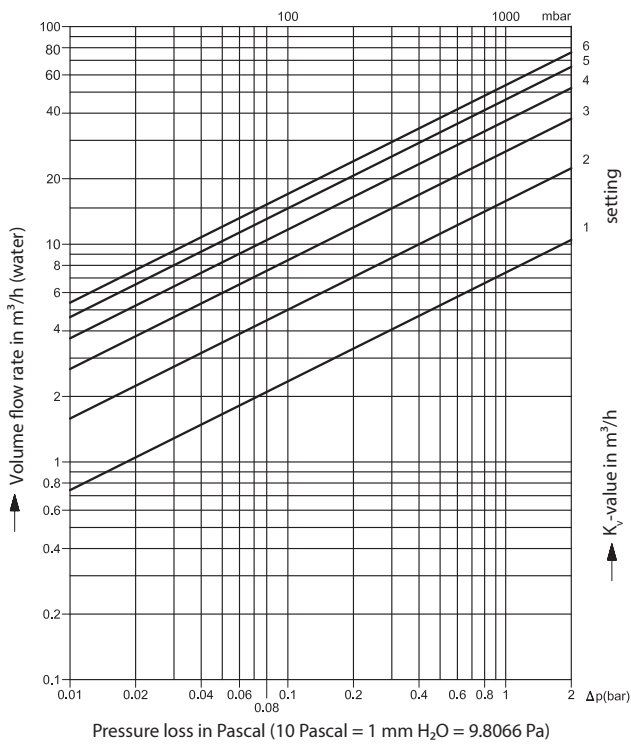

DN 50 / PN 16 / PN 25

Setting	k <sub>v</sub> -value
1	7.4
2	15.8
3	26.7
4	36.9
5	46.2
6	53.8

Max. permissible differential pressure in throttling function 1.5 /2.0 bar.

Max. permissible flow speed: ≤ 4 m/s

Condition: The flow must be free of cavitation.

### Flow characteristic

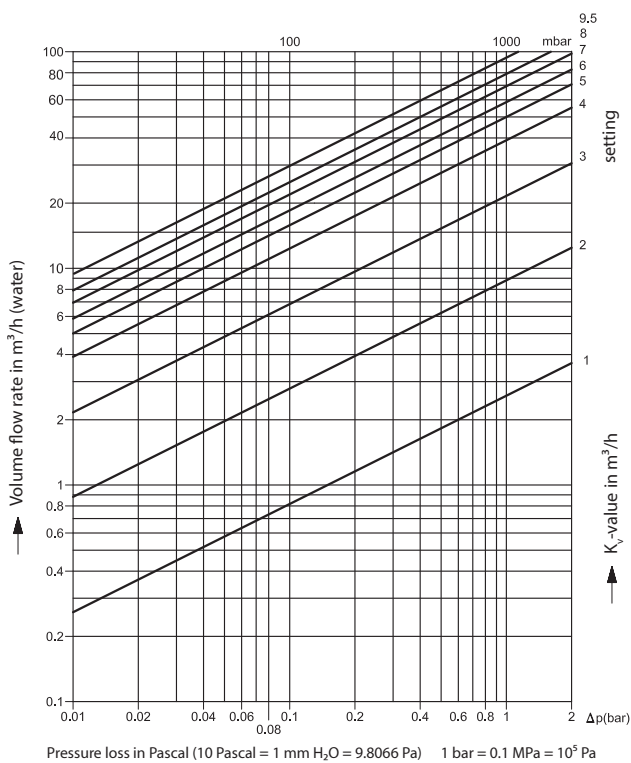
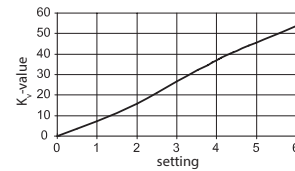

DN 60 / PN 16 / PN 25

Setting	k <sub>v</sub> -value
1	2.6
2	8.8
3	21.6
4	39.0
5	49.8
6	58.5
7	69.3
8	79.0
9	87.8
9.5	93.4

Max. permissible differential pressure in throttling function 1.5 /2.0 bar.

Max. permissible flow speed: ≤ 4 m/s

Condition: The flow must be free of cavitation.

### Flow characteristic

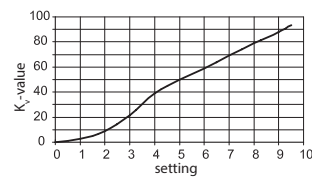

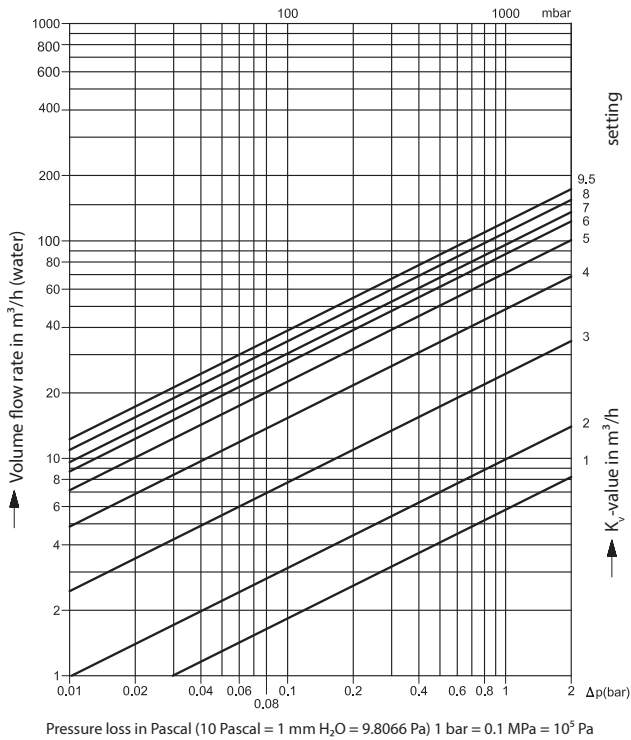

DN 80 / PN 16 / PN 25

Setting	$k_v$ -value
1	5.8
2	9.9
3	24.5
4	48.5
5	71.3
6	87.0
7	96.4
8	109.3
9.5	122.3

Max. permissible differential pressure in throttling function 1.5 / 2.0 bar.  
 Max. permissible flow speed:  $\leq 4$  m/s  
 Condition: The flow must be free of cavitation.

**Flow characteristic**

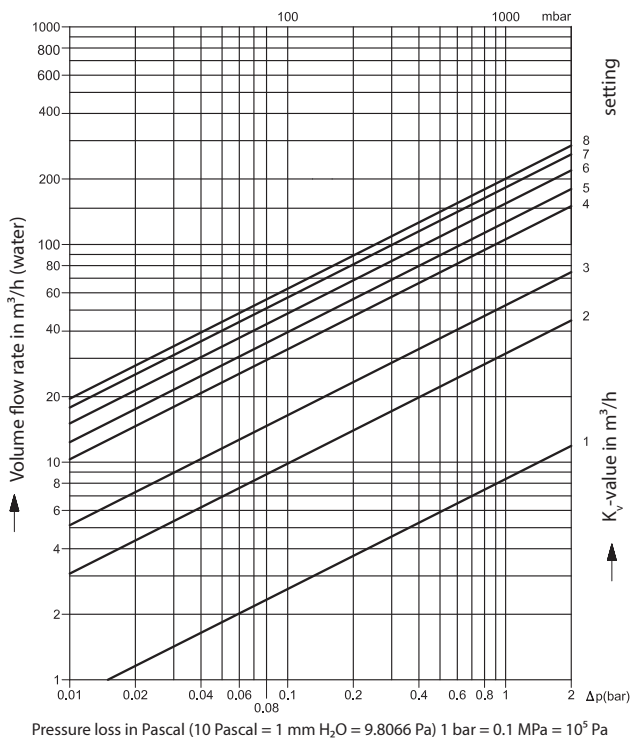
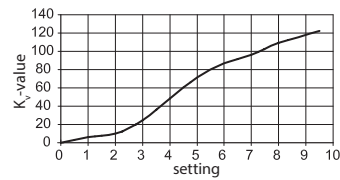

DN 100 / PN 16 / PN 25

Setting	$k_v$ -value
1	8.3
2	32.4
3	72.9
4	107.2
5	128.2
6	152.8
7	180.0
8	200.0

Max. permissible differential pressure in throttling function 1.5 / 2.0 bar.  
 Max. permissible flow speed:  $\leq 4$  m/s  
 Condition: The flow must be free of cavitation.

**Flow characteristic**

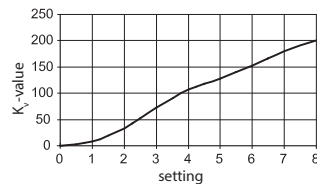

**Starting**

During system start – opening the shut-off on ASV-PV and partner valve-please secure that there is the same static pressure on both sides or higher pressure on upper side of the membrane. If filling is done by opening ASV-PV and partner valve, please make sure there is a pressure on the upper side of the membrane by opening partner valve first before ASV-PV is opened.

## Design

### ASV-PV (DN 50)

1. Shut-off knob
2. Differential pressure setting spindle
3. O-ring
4. Reference spring
5. Impulse tube connection
6. Diaphragm element
7. Control diaphragm
8. Pressure-relieved valve cone
9. Valve body
10. Seat

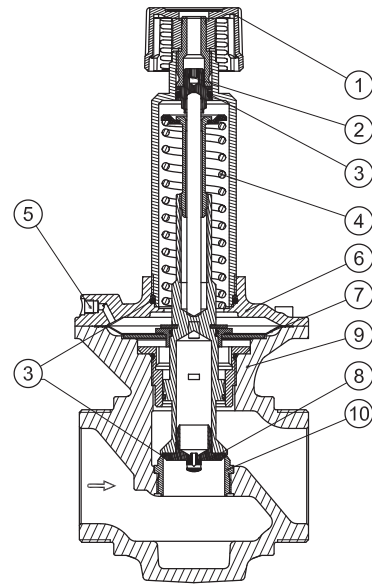

n (turns)	5-25 (kPa)	20-40 (kPa)	35-75 (kPa)	60-100 (kPa)
0	25	40	75	100
1	24	39	73	98
2	23	38	71	96
3	22	37	69	94
4	21	36	67	92
5	20	35	65	90
6	19	34	63	88
7	18	33	61	86
8	17	32	59	84
9	16	31	57	82
10	15	30	55	80
11	14	29	53	78
12	13	28	51	76
13	12	27	49	74
14	11	26	47	72
15	10	25	45	70
16	9	24	43	68
17	8	23	41	66
18	7	22	39	64
19	6	21	37	62
20	5	20	35	60

## Factory presetting

$\Delta p$ setting range (kPa)	kPa
5-25	10
20-40	30
35-75	60
60-100	80

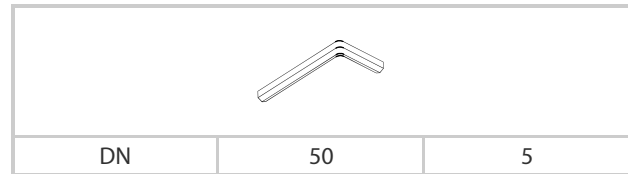

ASV-PV is designed to maintain a constant set differential pressure. Via an internal connection and together with the reference spring (4), pressure in the return pipe acts on the underside of the control diaphragm (7) while via an impulse tube (5), pressure in the flow pipe acts on the top of the diaphragm. In this way the balancing valve maintains adjusted differential pressure.

The ASV-PV valves are sold in four different  $\Delta p$  setting ranges. The valves are factory-set to a defined value as described on Factory presetting table.

Use the following procedure to set the desired differential pressure:

the setting on ASV-PV can be changed by turning the setting spindle (2).

Turning the spindle clockwise increases the setting; turning it counter clockwise reduces the setting.

If the setting is not known, turn the spindle fully clockwise. With this setting on ASV-PV is at maximum value within setting range. Now turn the spindle a number of times (n) as described until the required differential pressure setting is obtained.

## ASV-PV (DN 65-100)

1. Shut-off knob
2. Differential pressure setting spindle
3. O-ring
4. Flat gasket
5. Reference spring
6. Impulse tube connection
7. Diaphragm element
8. Control diaphragm
9. Pressure-relieved valve cone
10. Valve body
11. Seat
12. Measuring holes-plugged
13. Air-vent

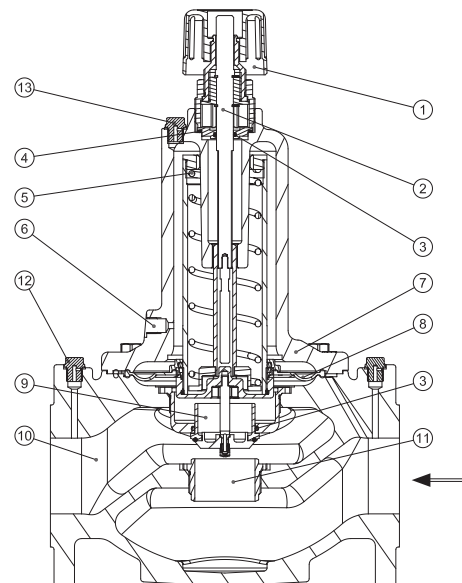

n (turns)	20-40 (kPa)	35-75 (kPa)	60-100 (kPa)
0	40	75	100
1	39	74	99
2	38	73	98
3	37	72	97
4	36	71	96
5	35	70	95
6	34	69	94
7	33	68	93
8	32	67	92
9	31	66	91
10	30	65	90
11	29	64	89
12	28	63	88
13	27	62	87
14	26	61	86
15	25	60	85
16	24	59	84
17	23	58	83
18	22	57	82
19	21	56	81
20	20	55	80

n (turns)	20-40 (kPa)	35-75 (kPa)	60-100 (kPa)
21	-	54	79
22	-	53	78
23	-	52	77
24	-	51	76
25	-	50	75
26	-	49	74
27	-	48	73
28	-	47	72
29	-	46	71
30	-	45	70
31	-	44	69
32	-	43	68
33	-	42	67
34	-	41	66
35	-	40	65
36	-	39	64
37	-	38	63
38	-	37	62
39	-	36	61
40	-	35	60

### Factory presetting

$\Delta p$ setting range (kPa)	kPa
20-40	30
35-75	60
60-100	80

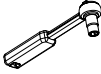
		
DN	65	13
	80	13
	100	13

## MSV-F2 DN 50-100

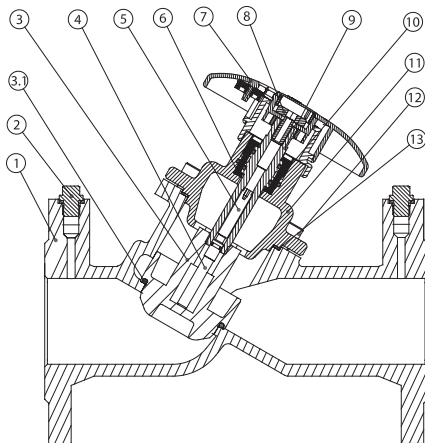

MSV-F2 DN 50-80

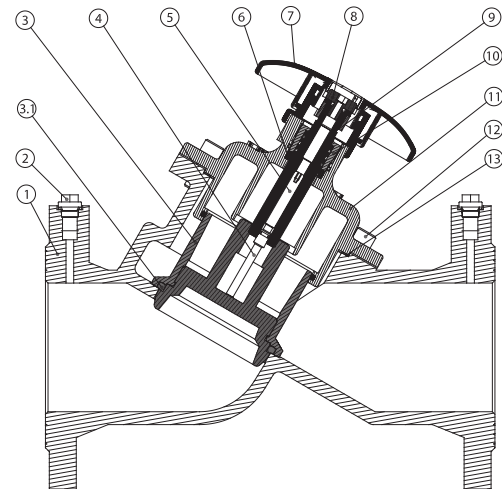

MSV-F2 DN 100

1. Body EN-GJL250
2. Plug
3. Valve cone
- 3.1. Seat soft sealing
4. Rod
5. Stroke limiter/Allen screw
6. Gasket

7. Handwheel with display - DN 50-100 plastic
8. Fixed screw
9. Spindle
10. Stuffing box
11. Bonnet
12. Allen screw /Hexagon screw
13. Flat gasket

**Partner valves** MSV-F2<sup>1)</sup> are to be used together with the automatic balancing valves ASV-PV to control differential pressure in the risers.

### Impulse tube connection

The impulse line must be connected to impulse tube connection piece (2) (adaptor sold as accessory). In working position, one of test plugs needs to be open while other closed.

There are two possible configurations, with partner valve inside or outside control loop.

It can be chosen by impulse tube connection side:

- Partner valve outside controlled loop: opened outlet test plug
- Partner valve inside controlled loop: opened inlet test plug

<sup>1)</sup> For more information see MSV-F2 datasheet

**MSV-F2** is manual presetting and shut-off valves. The valves have position indicator and stroke limiter as standard. Hood of spindle is integrated with stroke limiter. Setting can be locked.

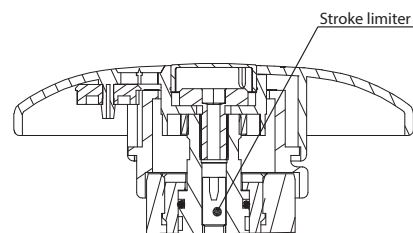

Valves have built in flow limitation

## Materials

### Material of parts in contact with water

Valve body	Grey cast iron EN-GJL-250 (GG 25)	Cast iron EN-GJL 250 (GG 25)
Cone	Stainless steel	CW602N
Membrane / O-rings	EPDM	
Spring	Stainless steel	-

### Fitting

For valves with external thread Danfoss offers threaded or welded tailpieces as accessory.

Nut	brass
Tailpiece welding	steel
Tailpiece threaded	brass

## Pressure and temperature data

### Measurement of flow and differential pressure

MSV-F2 is equipped with two test plugs so that the differential pressure across the valve can be measured using Danfoss measuring equipment or any other measuring device. Valve can be converted to actual flow.

**Note:** When measuring sized flow, all radiator valves must be fully open (nominal flow).

### Measurement of differential pressure ( $\Delta p$ ) across riser.

Fit a measuring connector (Danfoss code no. **003L8143**) on the ASV-PV balancing valve drain connection (DN 50) or threaded connection closer to the terminal unit (TU).

Measurements must be taken between the test plug at MSV-F2 valve port B and the measuring connector on the ASV-PV.

### Pressure testing

Max. test pressure: 25 bar

When pressure testing the system you must secure that both sides of the membrane have the same static pressure to prevent damage of the pressure controller. That means the impulse tube must be connected and any needle valves must be open.

## Dimensions

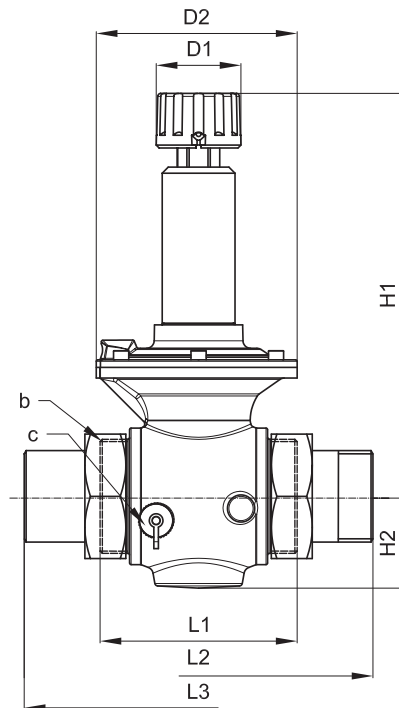

### ASV-PV

DN	$\Delta p$ setting range	L1	L2	L3	H1	H2	D1	D2	b	c
	kPa	mm							ISO 228/1	
50	5-25	130	244	234	232	61	55	133	G 2 1/2	G 3/4 A
	20-40									
	35-75				273					
	60-100									

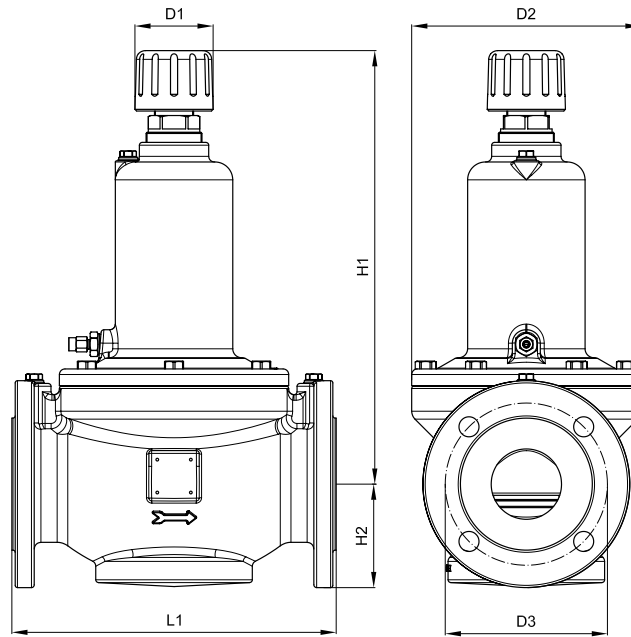

**ASV-PV**

DN	L1	H1	H2	D1	D2	D3
65	290	385	93	68	205	145
80	310	390	100	68	218	160
100	347	446	112	68	248	180

**Installation**

ASV-PV must be installed in the return pipe with flow in the direction of the arrow on the valve body. Partner valves (MSV-F2) must be installed in the flow pipe, with flow in the direction of the arrow on the valve body. The impulse tube must be installed between partner valve and ASV-PV.

The impulse tube must be flushed through before installation. ASV-PV and MSV-F2 must in addition be installed as determined by installation conditions.

**003L8151**

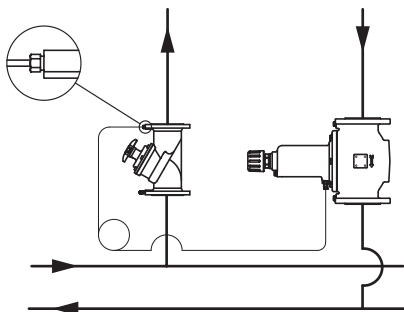

**003Z0691**

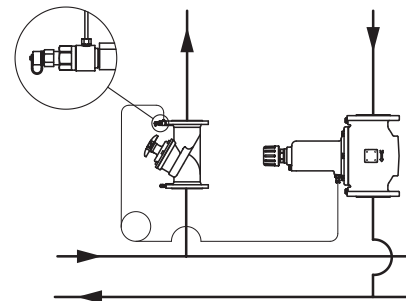

## Certificates, declarations and approvals

The list contains all certificates, declarations, and approvals for this product type. Individual code number may have some or all of these approvals, and certain local approvals may not appear on the list.

When you click on the link you will be directed to the latest version of the 'Declaration of Conformity'. Products developed and sold before this date of issue conform to the directives/standards in force at the time of their sale.

Approval type	Title	Certification body	Approval topic
EU Declaration	<a href="#">EU-declaration BF27112024-en01</a>	Danfoss	PED, Pressure
UA Declaration	<a href="#">Danfoss UA 2023-01-23 MTC ASV RA FH RAX PL03 PL28</a>	Danfoss	PED, Pressure
Pressure Safety Certificate	<a href="#">CE-0062-PED-H-DAF 002-24-DNK-rev-A</a>	BV - Bureau Veritas	PED, Pressure
Pressure Safety Certificate	<a href="#">LLC CDC EURO-TYSK UA.TR.089.1011.01-22</a>	LLC CDC EURO TYSK - Ukraine	PED, Pressure
Export Control Declaration	<a href="#">Automatic balancing and Pressure independent control valves</a>	Danfoss	
Manufacturer's Declaration	<a href="#">Danfoss MD BF20072023-en02.01</a>	Danfoss	PED, Pressure, EU RoHS

## Tender text

### ASV-PV tender text

#### 1. Tender text

- Product is differential pressure controller for automatic hydronic balance of heating and cooling systems.
- The differential pressure controller should be based on integrated membrane element.
- Valves should have shut-off function separated from the setting mechanism. Shut-off service function should be possible with a hand knob.
- The setting of differential pressure should be hidden to prevent unauthorized change of setting.
- The differential pressure setting should be linear throughout the setting range (1 turn 1 kPa or 1 turn 2 kPa depending on dimension).
- Packaging of differential pressure controller should contain impulse tube (1.5 m)
- Valve should be delivered in reliable packaging for safe transport and handling.

#### 2. Product characteristics:

- Pressure class: PN 16
- Temperature range: -10 ... +120 °C.
- Connection size: DN 50-100
- Connection type (depending on dp setting range): External thread ISO 228/1 (DN15-50) and Flange EN 1092-2 (DN 65-100)
- $\Delta p$  setting range: 5-25 kPa (DN 50), 20-40 kPa (DN 50-100), 35-75 kPa (DN 50-100) and 60-100 kPa (DN 65-100).
- Installation: differential pressure controller should mounted on return pipe with connection via impulse tube to supply pipe.

Nominal diameter: \_\_\_\_\_

Connection: \_\_\_\_\_

Adjustment range from-to: \_\_\_\_\_ kPa

Produced by: Danfoss Type: ASV-PV

Ordering no.: **003L**\_\_

## Contact details

### Online support

Danfoss offers a wide range of support along with our products, including digital information, software, mobile apps and expert guidance. See the possibilities below.



#### The Danfoss Design center

Discover the Design Center, our advanced digital platform that streamlines product selection. With integrated tools and enhanced type pages, it's simpler than ever to access product information and documentation, and to select the right products. Check the availability of Danfoss products at partner locations and enjoy seamless transitions from selection to purchase with our basket-to-basket functionality. Whether you're buying from our distributors or directly from the Product Store, the Design Center simplifies your experience. Learn more at: [designcenter.danfoss.com](https://designcenter.danfoss.com).



#### The Danfoss product store

The Danfoss Product Store is a one-stop shop available 24/7 for our customers, no matter where you are in the world or what area of industry you work in. Browse our catalog, check product details and documentation, view your prices and product availability, and quickly finalize your purchase. Start browsing at: [store.danfoss.com](https://store.danfoss.com).



#### Danfoss Partner Portal/Product Data tool

Designed to support you with easy access to product data extracts, essential resources, tools, and information. The Partner Portal provides a centralized hub for product documentation, training materials, marketing assets, and technical support, ensuring you have everything you need to succeed and grow your business with Danfoss. The Partner Portal is available 24/7 at: [partner.danfoss.com](https://partner.danfoss.com) and is ready to support your business.



#### Find technical documentation

Find technical documentation you need to get your project up running. Get direct access to our official collection of data sheets, certificates and declarations, manuals and guides, 3D models and drawings, case stories, brochures, and much more. Start searching now at: [documentation.danfoss.com](https://documentation.danfoss.com).



#### Danfoss Learning

Danfoss Learning is a free online learning platform. It features courses and materials specifically designed to help engineers, installers, service technicians, and wholesalers better understand the products, applications industry topics, and trends that will help you do your job better. Find your local Danfoss website here: [learning.danfoss.com](https://learning.danfoss.com).



#### Get local information and support

Local Danfoss websites are the main sources for help and information about our company and products. Find product availability, get the latest regional news, or connect with a nearby expert - all in your own language. Find your local Danfoss website here: [danfoss.com](https://danfoss.com).

#### Danfoss A/S

Climate Solutions . danfoss.com . +45 7488 2222

---

Any information, including, but not limited to information on selection of product, its application or use, product design, weight, dimensions, capacity or any other technical data in product manuals, catalogues description, advertisements, etc. and whether made available in writing, orally, electronically, online or via download, shall be considered informative, and is only binding if and to the extent, explicit reference is made in a quotation or order confirmation. Danfoss cannot accept any responsibility for possible errors in catalogues, brochures, videos and other material. Danfoss reserves the right to alter its products without notice. This also applies to products ordered but not delivered provided that such alterations can be made without changes to form, fit or function of the products. All trademarks in this material are property of Danfoss A/S or Danfoss group companies. Danfoss and the Danfoss logo are trademarks of Danfoss A/S. All rights reserved.

---