



H1F 060/080/110

H1F Bent Axis Fixed Displacement Motor



Revision history

Table of revisions

Date	Changed	Rev
April 2026	Several updates for 60 and 110cc, various other corrections	0302
June 2025	Added 110cc, updated speed sensor 7-32V table	0301
January 2025	Corrected HA and HT model code options	0202
March 2024	Added 60cc frame size	0201
September 2023	Updated title and speed sensor information	0102
September 2023	Initial Release	0101

General information

Design of H1F motor.....	4
About the H1F motors.....	5
H1F pictorial diagram.....	6
H1F system schematic.....	7

Technical specifications

H1F General specifications.....	8
H1F Physical properties.....	8
H1F Operating Parameters.....	9
H1F Required inlet pressure table (for cylinder block filling).....	9
H1F Required outlet pressure diagrams (minimum for short time usage).....	10
H1F required low pressure diagrams (minimum for extended usage).....	10
H1F Open circuit requirements.....	11
Fluid specifications.....	11
Determination of nominal motor size.....	12

Operation

H1F Shaft rotation direction.....	13
H1F Loop flushing shuttle spool.....	13
H1F loop flushing relief valve.....	14
Speed sensor.....	15
Temperature Range.....	15
Protection Characteristics.....	15
Mating connectors.....	15
Available Sensors.....	15
Speed sensor 4.5 – 8 V.....	16
Speed Sensor 7 - 32 V.....	16
H1F speed sensor position.....	17
H1F target ring.....	17

Operating parameters

H1F output speed.....	18
H1F system pressure.....	18
Case pressure.....	18
External shaft seal pressure.....	19
Temperature.....	20
Viscosity.....	20

System design parameters

Filtration system	21
Reservoir.....	21
Fluid Selection.....	22
Case Drain.....	22
Independent braking system.....	22
Bearing loads and life.....	22
Shaft Torque.....	22

Master Model Code

H1F size, version, port options.....	23
H1F B, C, D, E Options.....	23
H1F endcap, flange and housing options.....	23
H1F shaft, sensor, loop flushing shuttle system options.....	24
H1F loop flushing, special hardware options.....	25
H1F HPRV and paint options.....	25

Flange and housing dimensions

H1F SAE flange design.....	27
H1F SAE flange design ports per ISO 6149-1.....	29
H1F SAE mounting flange design per ISO 3019/1.....	29
H1F DIN flange design.....	31
H1F DIN flange design ports per 6149-1.....	34
H1F DIN mounting flange design per ISO 3019/2.....	34
H1F Cartridge flange design.....	35
H1F Cartridge flange design ports per ISO 6149-1.....	37
H1F Cartridge mounting flange design.....	37

General information

Design of H1F motor

Cross-section of H1F motor

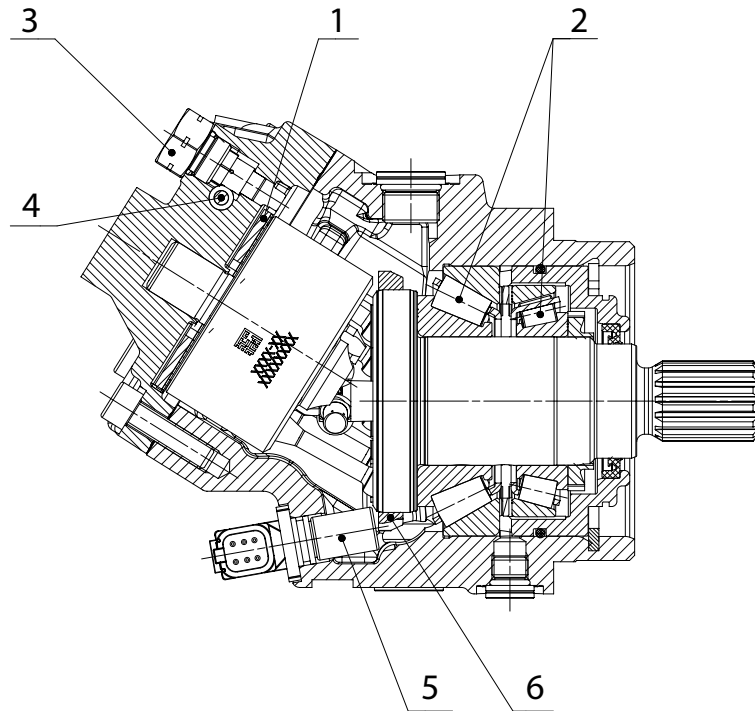

1. Bearing plate
2. Tapered roller bearing
3. Loop flushing relief valve
4. Loop flushing shuttle spool
5. Speed sensor
6. Speed ring

About the H1F motors

Series H1 fixed displacement motors are bent axis design, incorporating spherical pistons.

These motors are designed to be combined with other products in closed or open circuit systems to transfer hydraulic power.

High performing 32 degree maximum angle, creates opportunities to easily improve the machine performance for:

- Multi-motor applications requiring optimized work and transport modes (i.e. wheel loader, mobile crane, drill rigs, winches, harvestors).

SAE, Cartridge and DIN flange with axial, side or twin high pressure port configurations are available. Loop flushing is also available with these options.

Speed sensor options are available to cover all frame sizes and flange styles.

They are capable of sensing the following, all in one package:

- Speed
- Direction (Group "J": option "S" and option "B")
- Temperature (Group "J": options "S" and option "B")

H1F pictorial diagram

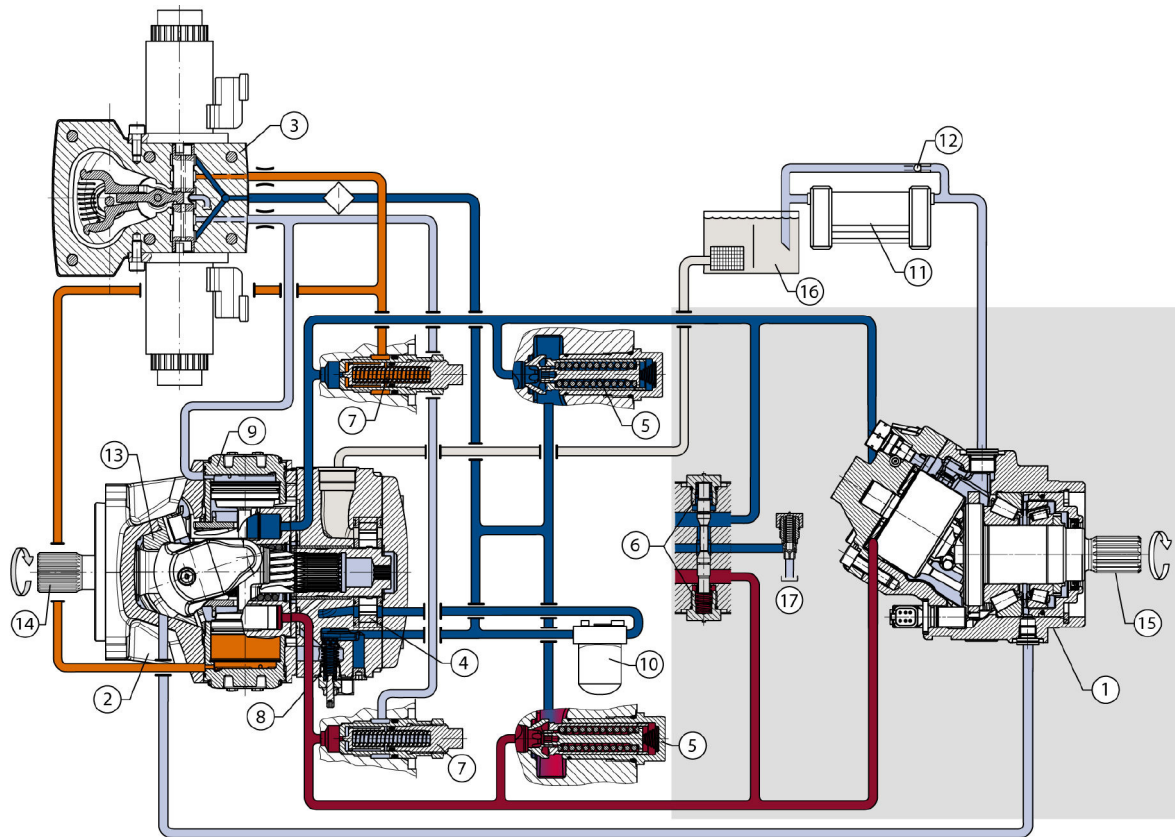

- Working loop A (Low pressure) and charge pressure
- Working loop B (High pressure)
- Servo pressure
- Case drain
- Suction

- | | |
|---|--|
| 1. Bent Axis Fixed Displacement Motor | 10. Charge Pressure Filter |
| 2. Axial Piston Variable Displacement Pump | 11. Heat Exchanger |
| 3. Electric Displacement Control (EDC) | 12. Heat Exchanger Bypass Valve |
| 4. Charge Pump | 13. Pump Swashplate |
| 5. Charge Check / High Pressure Relief Valve | 14. Input Shaft |
| 6. Loop Flushing Valve | 15. Output Shaft |
| 7. Pressure Limiter Valve | 16. Reservoir |
| 8. Charge Pressure Relief Valve | 17. to Motor Case |
| 9. Servo Cylinder | |

H1F system schematic

System schematic H1 pump and H1F motor

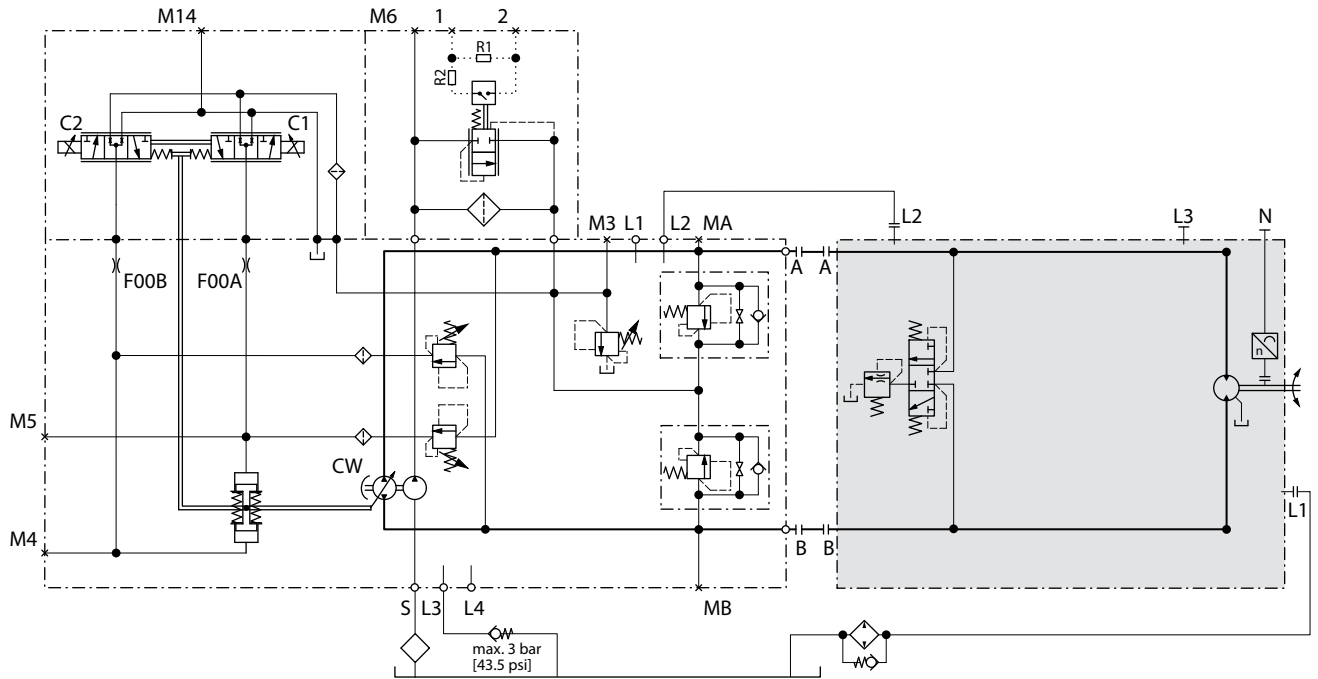

The schematic above shows the function of a hydrostatic transmission using an H1 axial variable displacement pump with electric proportional displacement control (EDC) and an H1 fixed displacement motor with integrated loop flushing device.

Technical specifications

H1F General specifications

General specifications

Design	Piston motor with fixed displacement bent axis design
Direction of rotation	Bi-directional
Pipe connections	<i>Main pressure ports:</i> ISO split flange boss <i>Remaining ports:</i> Metric straight thread O-ring boss
Recommended installation	Discretionary, the housing must always be filled with hydraulic fluid

H1F Physical properties

Physical properties

Features	Unit	Size		
		060	080	110
Displacement (max)	cm ³ [in ³]	60.1 [3.67]	80.8 [4.93]	110.1 [6.71]
Theoretical flow at max. displ.	at max. speed l/min [US gal/min]	330 [87.2]	400 [105.7]	534 [141.1]
Theoretical torque at max. displacement	N·m/bar [lb·in/1000 psi]	0.96 [583]	1.27 [777]	1.75 [1070.7]
Theor. corner power at rated speed and max. working pressure ($\Delta p = 450$ bar [6527 psi])	kW [hp]	248 [332.6]	330 [442.5]	400.5 [537.1]
Mass moment of inertia of rotating components	kg·m ² [slug·ft ²]	0.0031 [0.0023]	0.0063 [0.0047]	0.0108 [0.0080]
Case volume	l [US Gal]	0.8 [.21]		

Weight dry

Configuration	Size		
	060	080	110
SAE	18.0 kg [39.7 lb]	22.1 kg [48.7 lb]	32.2 kg [71.0 lb]
DIN	18.2 kg [40.1 lb]	22.9 kg [50.5 lb]	31.6 kg [69.7 lb]
Cartridge	18.5 kg [40.8 lb]	23.3 kg [51.4 lb]	31.3 kg [69.0 lb]

Mounting flange

Configuration	Size		
	060	080	110
SAE ISO 3019/1	127-4 (SAE C) 4-bolt	127-4 (SAE C) 4-bolt	152-4 (SAE-D) 4-bolt
DIN ISO 3019/2, B4	Flange 125 B4 HL 4-bolt	140 HL 4-bolt	160 HL 4-bolt
Cartridge	Pilot dia 160mm, 2-bolt (200 dist) M16	Pilot Ø190 mm, 2-bolt (224 dist.) M20	Pilot Ø200 mm, 2-bolt (250 dist.) M20

Customer ports

Configuration	Size		
	060	080	110
Axial and radial ¹⁾	DN19 typ 1	DN25 typ 1	DN32
L1, L2 ²⁾	M22x1,5		M27x2,0
Bleed port ³⁾	M14x1,5		

¹⁾ Split flange Boss per ISO6162, 40 MPa series

²⁾ Metric O-ring boss

³⁾ Countersink may be deeper than specified in the standard.

H1F Operating Parameters

Output Speed

Output Speed	Displacement	Unit	Size		
			060	080	110
Rated	Maximum 32°	min ⁻¹	5000	4500	4350
Maximum	Maximum 32°	(rpm)	5500	5000	4850

System and Case Pressure, Ambient Temperature

Parameter		All sizes
System pressure	Maximum working delta	450 bar [6527 psi]
	Maximum working abs	480 bar [6962 psi]
	Max delta	480 bar [6962 psi]
	Max abs	510 bar [7397 psi]
	Min low loop	7.5 bar [109 psi]
Case pressure	Rated	3 bar [44 psi]
	Maximum	5 bar [73 psi]
	Minimum	0.3 bar [4 psi]
Ambient temperature ¹⁾	Maximum	70 °C [158 °F]
	Minimum	-40 °C [-40 °F]

¹⁾ Air temperature close to the unit.

H1F Required inlet pressure table (for cylinder block filling)

60cc / 80cc

Speed (RPM)	Pressure (Bar)
1500	2
2600	3
3400	4

110cc

Speed (RPM)	Pressure (Bar)
1500	2
2500	3
3500	5
4500	8

This pressure ensures that the cylinder block will be properly filled and that there is no pulling between piston and shaft.

The required pressure is 0 bar at 0 rpm and increases with rpm.

 **Note**

For **open circuit** applications it is not allowed to operate above rated speed. For **closed circuit** applications operating between rated and max. speed, please contact your local Danfoss Power Solutions representative.

H1F Required outlet pressure diagrams (minimum for short time usage)

60cc / 80cc

Speed (RPM)	Pressure (Bar)
1500	2
2600	3
3400	4

110cc

Speed (RPM)	Pressure (Bar)
1500	2
2500	3
3500	5
4500	8

The required outlet pressure (above case pressure) makes sure, that there is no pulling between piston and shaft.

The required pressure is 0 bar at 0 rpm and increases with rpm.

 **Note**

For **open circuit** applications it is not allowed to operate above rated speed. For **closed circuit** applications operating between rated and max. speed, please contact your local Danfoss Power Solutions representative.

H1F required low pressure diagrams (minimum for extended usage)

60cc / 80cc

Speed (% of max)	Pressure (Bar)
50%	10
67%	15
80%	20
90%	25
100%	30

110cc

Speed (RPM)	Pressure (Bar)
3000	10
3750	15
4300	20
4850	25

These minimum pressures are required for a high duty cycle, defined as 200 hours at 350 bar. Similarly, a duty cycle of 200 hours at 250 bar requires 50% of these pressures.

This low pressure (above case pressure) is required to prevent cavitation, which comes from the pressure change in the cylinder block. There is very high flow velocity in the porting grooves of the valve segment, which causes cavitation.

H1F Open circuit requirements

H1 bent axis motors may be used in Open Circuit (OC) applications.

Since loop flushing is typically not used in OC-applications it is essential to provide sufficient cooling capacity. This can be done by motor case cross flushing. The flow rate needs to be adjusted to the cooling demand.

The highest case drain outlet port must always be used for the return flow to the cooler or tank.

The motor case and the working lines connected to Port A and B must be kept full of oil at all times, whether in a dynamic or static condition.

The plumbing must not allow the oil to drain down and be replaced with air in the rotating group.

The minimum pressure in the inlet port and the outlet port, must be equal or higher as shown in the tables. *H1F Required inlet pressure table (for cylinder block filling)* on page 9 .

Counter balance valves may be used to maintain the minimum pressure requirements. Danfoss meter-in / meter-out PVG technology may be used. Check valves and sufficient charge pressure supply are also possible.

At no time shall the motor be allowed to operate above the rated speed limits. If flow limiter valves are used, they must be selected accordingly. This ensures proper function under all conditions.

Valve blocks, such as counter balance valves attached to the inlet and/or outlet ports, must not interfere with any part of the motor. A review of the outline drawings or appropriate 3D models must be completed.

Fluid specifications

Fluid specifications

Features		Unit	All sizes
Viscosity	Minimum intermittent	mm ² /s [SUS]	7 [49]
	Recommended range		12-80 [66-366]
	Maximum intermittent		1600 [7416]
Temperature range ¹⁾²⁾	Minimum	°C [°F]	-40 [-40]
	Rated		104 [220]
	Maximum intermittent		115 [240]
Cleanliness and Filtration	Required cleanliness per ISO 4406	-	22/18/13
	Efficiency (charge pressure filtration)	β-ratio	β ₁₅₋₂₀ = 75 (β ₁₀ ≥ 10)
	Efficiency (suction / return line filtration)		β ₃₅₋₄₅ = 75 (β ₁₀ ≥ 2)
	Recommended inlet screen mesh size	µm	100 – 125

¹⁾ At the hottest point, normally case drain port.

²⁾ Minimum: cold start, short term t<3 min, p<50 bar, n<1000 rpm.

Determination of nominal motor size

Based on SI units

$$Q_e = \frac{V_g \cdot n}{1000 \cdot \eta_v}$$

$$M_e = \frac{V_g \cdot \Delta p \cdot \eta_{mh}}{20 \cdot \pi}$$

$$P_e = \frac{M_e \cdot n}{9550} = \frac{Q_e \cdot \Delta p \cdot \eta_t}{600}$$

$$n = \frac{Q_e \cdot 1000 \cdot \eta_v}{V_g}$$

Where:

Q_e	Input flow (l/min)
M_e	Output torque (N·m)
P_e	Output power (kW)
n	Speed (min ⁻¹)
V_g	Motor displacement per rev. (cm ³ /rev)
p_{high}	High pressure (bar)
p_{low}	Low pressure (bar)
Δp	High pressure minus Low pressure (bar)
η_v	Motor volumetric efficiency
η_{mh}	Mechanical-hydraulic efficiency
η_t	Motor total efficiency ($\eta_v \cdot \eta_{mh}$)

Based on US units

$$Q_e = \frac{V_g \cdot n}{231 \cdot \eta_v}$$

$$M_e = \frac{V_g \cdot \Delta p \cdot \eta_{mh}}{2 \cdot \pi}$$

$$P_e = \frac{V_g \cdot n \cdot \Delta p \cdot \eta_t}{396\,000}$$

$$n = \frac{Q_e \cdot 231 \cdot \eta_v}{V_g}$$

Where:

Q_e	Input flow [US gal/min]
M_e	Output torque [lb·in]
P_e	Output power [hp]
n	Speed [rpm]
V_g	Motor displacement per rev. [in ³ /rev]
p_{high}	High pressure [psi]
p_{low}	Low pressure [psi]
Δp	High pressure minus Low pressure [psi]
η_v	Motor volumetric efficiency
η_{mh}	Mechanical-hydraulic efficiency
η_t	Motor total efficiency ($\eta_v \cdot \eta_{mh}$)

Operation

H1F Shaft rotation direction

Shaft rotation direction is determined with a view from the shaft end.

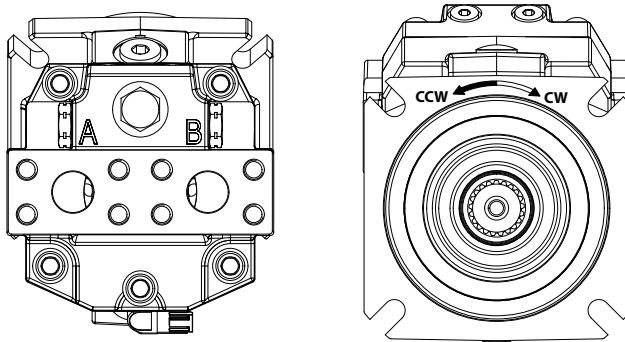

Flow into port A	Clockwise
Flow into port B	Counterclockwise

H1F Loop flushing shuttle spool

An integral loop flushing shuttle spool is used to separate system A and system B pressures.

System delta pressure will cause the shuttle spool to shift, allowing the low side system pressure to flow to the loop flushing relief valve.

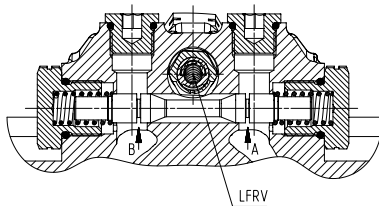

Legend:

- A** System loop A
- B** System loop B
- LFRV** to loop flushing relief valve

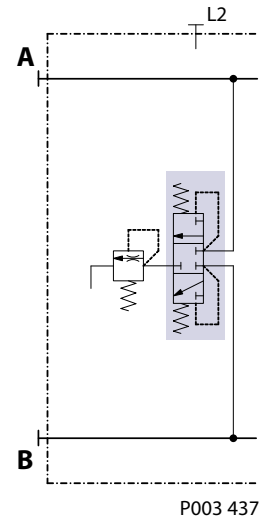

Warning

Unintended vehicle or machine movement hazard.

Excessive motor loop flushing flow may result in the inability to build required system pressure in some conditions. Maintain correct charge pressure under all conditions of operation to maintain pump control performance in hydrostatic systems.

H1F loop flushing relief valve

The loop flushing relief valve is incorporated into all H1 motors used in closed circuit applications to remove fluid from the low pressure side of the system circuit to meet cooling requirements.

The loop flushing relief valve is also used to facilitate the removal of contaminants from the loop.

The loop flushing valve is equipped with an orificed charge pressure relief valve designed with a cracking pressure of 16 bar [232 psi].

Valves are available with several orifice sizes to meet the flushing flow requirements of all system operating conditions.

A loop flushing defeat option is available.

Loop flushing relief valve (cross section)

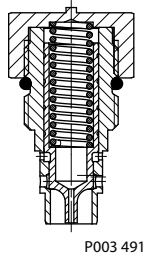

Loop flushing relief valve schematic

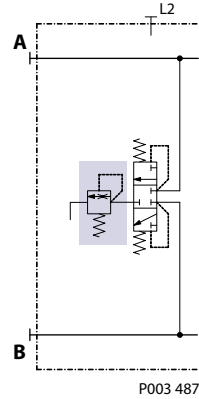

Loop flushing relief valve sizes

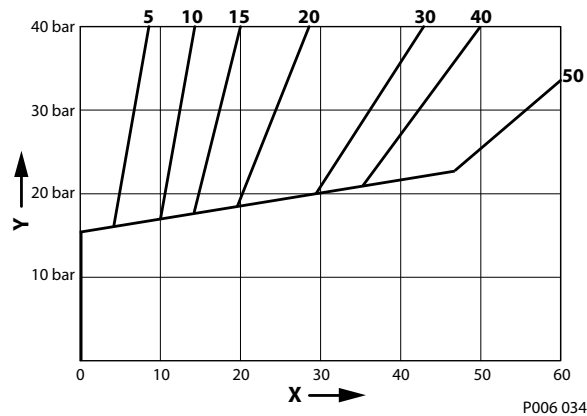

X Loop flushing flow (l/min)

Y Low system pressure minus case pressure (bar)

Speed sensor

The speed sensor is designed for rugged outdoor, mobile or heavy industrial speed sensing applications. The detection of the speed is contactless and does not need any calibration or adjustments.

For more information, see *Speed and Temperature Sensor, Technical Information*, **BC152886482203**.

Temperature Range

Parameter	Minimum	Maximum
Operation temperature range	-40 °C	104 °C

Note

115°C intermittent = short term; t < 1 min per incident and not exceeding 2 % of duty cycle based load-life.

Protection Characteristics

Parameter	Data
Protection Code (IP class) according IEC 60529 and DIN 40050	IP 67 (without connector installed) IP 69k (with connector installed)
EMC Emission	EN 61000-6-3
EMC Immunity (EMI)	100 V/m incl. 1 kHz AM 80 %; ISO 11452-5 and -2
ESD	EN 61000-4-2 Air discharge: 15 kV Contact discharge: 8 kV
Vibration	30 G (294 m/s ²)
Shock	50 G (490 m/s ²)
Case maximum pressure	5 bar [72.5 psi]

Mating connectors

There are available two types of mating connectors Assembly Bag DEUTSCH DTM06-6S, Black and Grey.

Ordering number	
11033865	11033863
Assembly Bag, DEUTSCH DTM06-6S-E004; black, (24-20 AWG) 0.21 -0.52 mm ²	Assembly Bag, DEUTSCH DTM06-6S, gray, (24-20 AWG) 0.21 -0.52 mm ²

Available Sensors

There are two speed sensors available according to different supply voltage range: 4.5 to 8 V_{DC} and 7 to 32 V_{DC}.

Description	Order number	
	149055	11232698
Supply voltage	4.5 – 8 V	7 – 32 V
Speed signals	Two, 90° Phase shift	Two, 90° Phase shift
Direction signal	One	One
Temperature signal	One	One

Note

For more information, see below.

Speed sensor 4.5 – 8 V

Speed sensor connector, 6-pin

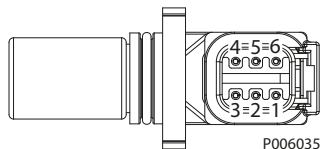

1. Speed signal 2
2. Direction signal
3. Speed signal 1
4. Supply
5. Ground
6. Temperature

Technical data

Parameter	Min.	Nom.	Max.	Note
Supply voltage	4.5 V _{DC}	5 V _{DC}	8 V _{DC}	Regulated supply voltage. Reverse polarity protected.
Supply protection	–	–	30 V _{DC}	Shuts off above 9 V.
Max. required supply current	–	–	25 mA	At supply voltage
Max. output current	–	–	50 mA	
Operation mode	NPN & PNP			Push-Pull amplifier
Temperature signal	-40°C = 2.318V	–	100°C = 0.675V	
Output low	5 %	8.5 %	12 %	Ratiometric output voltage Low state > 0 V to provide wire fault detection
Output high	88 %	91.5 %	95 %	
Detectable frequency range	1 Hz	–	10 000 Hz	
Ordering number	149055			
Color of connector	Black			

Speed Sensor 7 - 32 V

Speed Sensor 7 – 32 V_{DC} technical data and information about connector.

Speed sensor connector, 6-pin

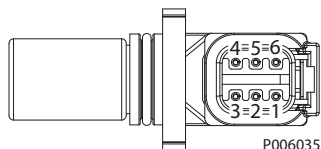

Pinout:

1. Speed signal 2
2. Direction signal
3. Speed signal 1
4. Supply
5. Ground
6. Temperature signal

Technical data

Parameter	Min.	Max.	Note
Supply voltage range	7 V _{DC}	32 V _{DC}	
Supply protection	–	36 V _{DC}	36 V _{DC} over voltage protection -36 V _{DC} permanent reverse polarity protection
Max. required supply current	–	30 mA	
Max. output current	–	50 mA	
Operation mode	NPN open collector		Internal 2k7 pull-up resistor to supply
Temperature signal	-40°C = 2.318V–		100°C = 0.675V
Output low signal range	2 %	8 %	Max. output voltage 24 V _{DC}
Output high signal range	55 %	85 %	

Technical data (continued)

Parameter	Min.	Max.	Note
Detectable frequency range	1 Hz	10 000 Hz	
Speed sensor order number	11232698		
Color of connector	Yellow		

H1F speed sensor position

Sensor position in cartridge housing

Cartridge housing

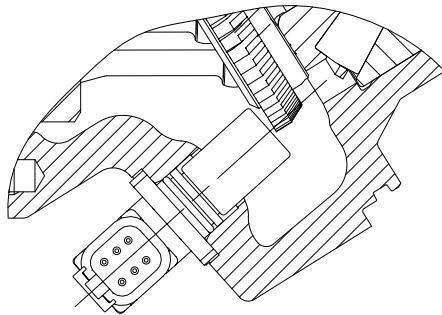

H1F target ring

Speed (target) rings vary according to the diameter of the cylinder block or shaft on which they are installed. The number of teeth is shown in the table below.

The number of speed (target) ring teeth

H1F size	060	080	110
Teeth	71	78	86

 **Note**

Excessive axial shaft loading during installation of motors with speed sensors and cartridge housings must be avoided. High axial shaft loads during installation of motors can lead to a movement of the shaft and damage the speed sensor.

Operating parameters

H1F output speed

Start and low speed stability. The motor produces maximum starting torque at maximum displacement. Stable operation can be achieved at 15–34 rpm, $\pm 5\%$, depending on system pressure, in applications that require low speed stability. Motor output speed becomes more stable as speed increases.

Rated speed is the highest output speed recommended at full power condition. Operating at, or below this speed will yield satisfactory product life. Do not exceed rated speed in open circuit applications.

Maximum speed is the highest operating speed permitted. Exceeding maximum speed reduces the product life and can cause loss of hydrostatic power and dynamic braking capacity. Never exceed the maximum speed limit under any operating conditions.

Operation between rated and maximum speed is reserved for **intermittent operation** (see *H1F Operating Parameters* on page 9) not to exceed 10 minutes durations, 2% of duty cycle based load-life, and 310 bar system delta pressure. Speed above rated are anticipated to occur during downhill braking (negative power). Contact factory for any operation above Rated speed when negative power is not involved.

During hydraulic braking and downhill conditions, the prime mover must be capable of providing sufficient braking torque in order to avoid pump over speed. This is especially important to consider for turbocharged and Tier 4 engines.

Warning

Unintended vehicle or machine movement hazard.

Exceeding maximum speed may cause a loss of hydrostatic drive line power and braking capacity. You must provide a braking system, redundant to the hydrostatic transmission, sufficient to stop and hold the vehicle or machine in the event of hydrostatic drive power loss. The braking system must also be sufficient to hold the machine in place when full power is applied.

H1F system pressure

System pressure is the differential pressure between high pressure system ports. It is the dominant operating variable affecting hydraulic unit life. High system pressure, which results from high load, reduces expected life. Hydraulic unit life depends on the speed and normal operating, or weighted average, pressure that can only be determined from a duty cycle analysis.

Application pressure is the high pressure relief or pressure limiter setting normally defined within the order code of the pump. This is the applied system pressure at which the driveline generates the maximum calculated pull or torque in the application.

Maximum working pressure is the highest recommended application pressure. Maximum working pressure is not intended to be a continuous pressure. Propel systems with application pressures at, or below, this pressure should yield satisfactory unit life given proper component sizing.

Maximum pressure is the highest allowable application pressure under any circumstance. For applications which are above the maximum working pressure, please contact Danfoss

Minimum pressure must be maintained under all operating conditions to avoid cavitation.

All pressure limits are differential pressures referenced to low loop (charge) pressure. Subtract the low loop gauge pressure from the high loop gauge pressure readings to compute the differential.

Summing pressure is the sum of both the low and high loop pressures. Summing pressure above 30 bar [435 psi] guarantees reliable use within the rated speed.

Case pressure

Under normal operating conditions, **the rated case pressure** must not be exceeded. During cold start, case pressure must be kept below maximum intermittent case pressure. Size drain plumbing accordingly.

 **Caution**

Possible component damage or leakage.

Operation with case pressure in excess of stated limits may damage seals, gaskets, speed sensors and/or housings, causing external leakage. Performance may also be affected since charge and system pressures are referenced to case pressure.

External shaft seal pressure

In certain applications, the output shaft seal may be exposed to external pressures. The shaft seal is designed to withstand an external pressure up to 0.25 bar [3.6 psi] above the case pressure. The case pressure limits must also be followed to ensure the shaft seal is not damaged.

Temperature

The high temperature limits apply at the hottest point in the transmission, which is normally the motor case drain. The system should generally be run at or below the published **rated temperature**.

The **maximum intermittent temperature** is based on material properties and should never be exceeded.

Cold oil will generally not affect the durability of the transmission components, but it may affect the ability of oil to flow and transmit power. Therefore, temperatures should remain 16 °C [30 °F] above the pour point of the hydraulic fluid.

The **minimum temperature** relates to the physical properties of component materials.

Size heat exchangers too keep the fluid within these limits. Danfoss recommends testing to verify that these temperature limits are not exceeded.

Viscosity

For maximum efficiency and bearing life, ensure that the fluid viscosity remains in the **recommended range**.

The **minimum viscosity** should be encountered only during brief periods of maximum ambient temperature and severe duty cycle operation.

The **maximum viscosity** should be encountered only at cold start.

System design parameters

Filtration system

To prevent premature wear, ensure that only clean fluid enters the hydrostatic transmission circuit. A filter capable of controlling the fluid cleanliness to ISO 4406, class 22/18/13 (SAE J1165) or better, under normal operating conditions, is recommended. These cleanliness levels cannot be applied for hydraulic fluid residing in the component housing/case or any other cavity upon delivery from the factory.

The filter may be located on the pump (integral) or in another location (remote or suction). The integral filter has a filter bypass sensor to signal the machine operator when the filter requires changing. Filtration strategies include suction or pressure filtration. The selection of the filter strategy depends on a number of factors including the contaminant ingress rate, the generation of contaminants in the system, the required fluid cleanliness, and the desired maintenance interval. Filters are selected to meet the above requirements using rating parameters of efficiency and capacity.

Filter efficiency can be measured with a Beta ratio (β_x). For simple suction-filtered closed circuit transmissions and open circuit transmissions with return line filtration, a filter with a β -ratio within the range of $\beta_{35-45} = 75$ ($\beta_{10} \geq 2$) or better has been found to be satisfactory. For some open circuit systems, and closed circuits with cylinders being supplied from the same reservoir, a higher filter efficiency is recommended. This also applies to systems with gears or clutches using a common reservoir. For these systems, a charge pressure or return filtration system with a filter β -ratio in the range of $\beta_{15-20} = 75$ ($\beta_{10} \geq 10$) or better is typically required.

Because each system is unique, only a thorough testing and evaluation program can fully validate the filtration system. For more information, see *Design Guidelines for Hydraulic Fluid Cleanliness, Technical Information BC152886482150*.

Note

Filter β_x -ratio is a measure of filter efficiency defined by ISO 4572. It is defined as the ratio of the number of particles greater than a given diameter ("x" in microns) upstream of the filter to the number of these particles downstream of the filter.

Filtration, cleanliness level and β_x -ratio (recommended minimum)

Cleanliness per ISO 4406	22/18/13
Efficiency β_x (charge pressure filtration)	$\beta_{15-20} = 75$ ($\beta_{10} \geq 10$)
Efficiency β_x (suction and return line filtration)	$\beta_{35-45} = 75$ ($\beta_{10} \geq 2$)
Recommended inlet screen mesh size	100 – 125 μm

Reservoir

Proper sizing of the hydrostatic system reservoir will allow maximum volume changes during all system operating modes and increase de-aeration of the fluid as it passes through the tank. A suggested minimum total reservoir volume is $\frac{5}{8}$ of the maximum charge pump flow per minute with a minimum fluid volume equal to $\frac{1}{2}$ of the maximum charge pump flow per minute. This allows 30 seconds of fluid dwell time for removing entrained air at the maximum return flow. This is usually adequate to allow for a closed reservoir having no breather in most applications.

Locate the reservoir outlet to the charge pump inlet above the bottom of the reservoir to take advantage of gravity separation and prevent large foreign particles from entering the charge inlet line. A 100-125 mesh screen over the reservoir outlet port is recommended. Position the reservoir inlet for the fluid return to discharge below the normal fluid level and toward the interior of the tank. A baffle or baffles, between the inlet and outlet of the reservoir will further increase de-aeration and reduce surging of the fluid.

Fluid Selection

Ratings and performance data are based on operating with hydraulic fluids containing oxidation, rust and foam inhibitors. These fluids must possess good thermal and hydrolytic stability to prevent wear, erosion, and corrosion of motor components.

Caution

Never mix hydraulic fluids of different types.

Case Drain

A case drain line must be connected to the case outlets of each motor to return the internal leakage oil to the system reservoir. When filling the case before start up, use the highest case drain outlet to promote complete filling of the case. The case drain fluid is typically the hottest fluid in the system. It is highly recommended to route the case drain flow through a heat exchanger before it is returned to the reservoir.

In some applications, it may be required to provide additional cross-flushing of the motor. If the motor is used mainly in a high speed application, higher cooling requirements may be needed for the rotating kit and tapered roller bearings. Use the lowest case drain port as the inlet port and the highest case drain port as the outlet port. This will ensure that the case is full of oil at all times.

Apply unit case pressure ratings to case drain routing and design.

Independent braking system

Unintended vehicle or machine movement hazard.

You must provide a braking system, redundant to the hydrostatic transmission, sufficient to stop and hold the vehicle or machine in the event of hydrostatic drive power loss. The braking system must also be sufficient to hold the machine in place when full power is applied.

Bearing loads and life

Bearing life is a function of speed, system pressure, motor angle and any external side or thrust loads. The influence of motor angle includes displacement as well as direction. External side loads are found in some applications such as a helical gear without its own support bearings, installed directly on to the motor shaft. All external side loads will act to reduce the normal bearing life of the motor. Other life factors include oil type and viscosity.

When external side loads are present, the allowable radial shaft loads are a function of the load position relative to the mounting flange, the load orientation relative to the internal loads and the operating pressures of the hydraulic unit. In applications where external shaft loads cannot be avoided, the impact on bearing life can be minimized by proper orientation of the load. Optimal motor orientation is a consideration of the net loading on the shaft from the external load and the motor rotating kit.

Contact Danfoss for a bearing life review if external side loads and thrust loads are present.

Shaft Torque

Available shafts are capable to transmit the maximum torque capability at maximum working pressure. Lubrication or similar treatment of splined motor shaft is recommended for proper torque transmission.

For more information, see **Lubrication of Splined Shafts, Data Sheet, AI152986482538**.

Master Model Code

H1F size, version, port options

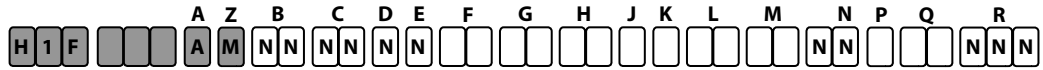

H1F frame size

Code	Displacement
060	60 cm ³ [3.66 in ³]
080	80 cm ³ [4.88 in ³]
110	110 cm ³ [6.71 in ³]
160	160 cm ³ [9.76 in ³] Coming soon
210	210 cm ³ [12.81 in ³] Coming soon
250	250 cm ³ [15.25 in ³] Coming soon

A – Product version

A	Revision code
---	---------------

Z – Port configuration

M	Metric, Customer O-Ring ports sealing according to ISO 6149-1
---	---

H1F B, C, D, E Options



B, C, D, E

Code	Note:
NN	Not used

H1F endcap, flange and housing options



F – End-cap (ISO 6162, type 2)

Code	Description	Port type	060	080	110
FS		Side port	X	X	X
FA	Endcap w/ loop flushing	Axial port		X	
FT		Twin port	X		X
HS		Side port	X	X	X
HA	Endcap w/o loop flushing	Axial port		X	
HT		Twin port	X		X

G – Flange and housing

Code	Description	060	080	110
VS	SAE flange motor housing (ISO 3019/1), with speed sensor port	X	X	X
DS	DIN flange motor housing (ISO 3019/2), with speed sensor port	X	X	X
CS	Cartridge flange motor housing, with speed sensor port	X		X
VN	SAE flange motor housing (ISO 3019/1), no speed sensor port	X	X	X
DN	DIN flange motor housing (ISO 3019/2), no speed sensor port	X	X	X
CN	Cartridge flange motor housing, no speed sensor port	X		X

H1F shaft, sensor, loop flushing shuttle system options



H – Shaft options according to speed ring

Code	Speed ring	Description	060	080	110
AN	No	14 teeth 12/24 pitch	X	X	
AS	Yes	ANSI 92.1 1970 class 5	X	X	
BN	No	21 teeth 16/32 pitch	X	X	
BS	Yes	ANSI 92.1 1970 class 5	X	X	
CN	No	23 teeth 16/32 pitch		X	
CS	Yes	ANSI 92.1 1970 class 5		X	
DN	No	27 teeth 16/32 pitch ANSI			X
DS	Yes	92.1 : 1996 class 5			X
EN	No	13 teeth 8/16 pitch ANSI			X
ES	Yes	92.1 : 1996 class 5			X
GN	No	W30x2x30x14x9g	X		
GS	Yes	DIN 5480	X		
HN	No	W35x2x30x16x9g	X	X	
HS	Yes	DIN 5480	X	X	
JN	No	W40x2x30x18x9g		X	X
JS	Yes	DIN 5480		X	X
KN	No	W45x2x30x21x9G			X
KS	Yes	DIN 5480			X
RN	No	Tapered Shaft 44-3, ISO	X	X	
RS	Yes	3019-1, no dust seal	X	X	
TN	No	Tapered Shaft 44-3, with	X	X	
TS	Yes	dust seal	X	X	

H – Shaft options according to speed ring (continued)

Code	Speed ring	Description	060	080	110
VN	No	Straight Key Shaft 40x82, ISO 3019-2		X	
VS	Yes			X	
WN	No	Straight Key Shaft 32-1, ISO 3019-1	X		
WS	Yes		X		
XN	No	Straight Key Shaft 30x60	X		
XS	Yes		X		
YN	No	Straight Key Shaft 35x58, DIN 748	X		
YS	Yes		X		
ZN	No	Straight Key Shaft 38-1, ISO 3019-1		X	
ZS	Yes			X	

J – Sensor

N	Plugged no speed sensor ring
B	Speed sensor, 7 V to 32 V, DEUTSCH DTM04-6P connector
S	Speed sensor, 4.5 V to 8 V, DEUTSCH DTM 04-6P connector
P	Plugged with speed sensor ring

K – Loop flushing shuttle system

Code	Description	060	080	110
A	Standard 6.5 bar [94 psi] shift pressure	X	X	X
N	No loop flushing function	X	X	X
W	No loop flushing function, option w/o parts	X	X	X

H1F loop flushing, special hardware options



L – Loop flushing relief valve (non-adjustable)

Code	Flow	060	080	110
05	5 l/min [1.321 US gal/min], 16 bar [232 psi] cracking pressure	X	X	-
10	10 l/min [2.642 US gal/min], 16 bar [232 psi] cracking pressure	X	X	X
NN	No loop flushing function	X	X	X
WN	No loop flushing function, option w/o parts	X	X	X

M – Special hardware feature

NN	Standard hardware fixed
----	-------------------------

H1F HPRV and paint options



P – HPRV A Setting

Code	Description
NN	Other

Q – HPRV B Setting

Code	Description
NN	Other

R – Paint options

Code	Description
NNN	Black paint and Danfoss nametag

Flange and housing dimensions

H1F SAE flange design

Axial ports

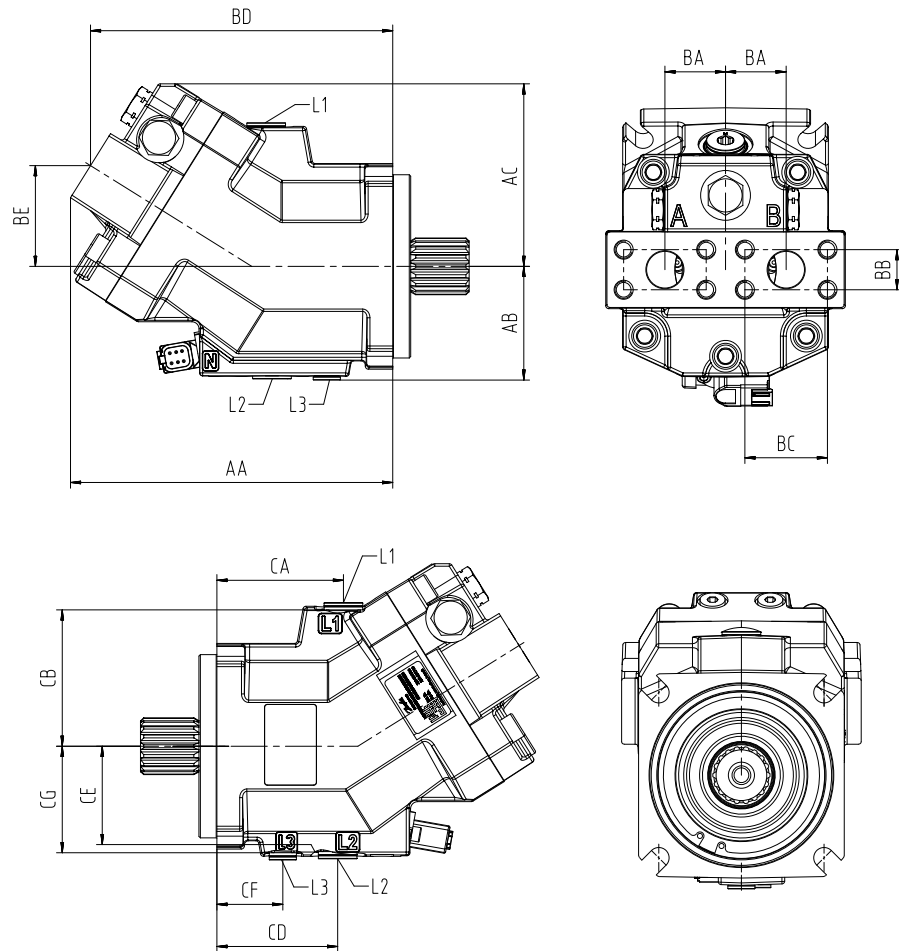

Axial ports dimensions, mm [in]

Callout	Size 080
AA	223.2 [8.787]
AB	78.8 [3.102]
AC	126.5 [4.980]
BA	42.0 [1.654]
BB	27.8 [1.094]
BC	57.2 [2.252]
BD	209.5 [8.248]
BE	69.8 [2.748]
CA	87.7 [3.45]
CB	94.5 [3.720]
CD	83.7 [3.295]
CE	73.0 [2.874]

Axial ports dimensions, mm [in] (continued)

Callout	Size 080
CF	45.7 [1.799]
CG	73.8 [2.906]

Side ports

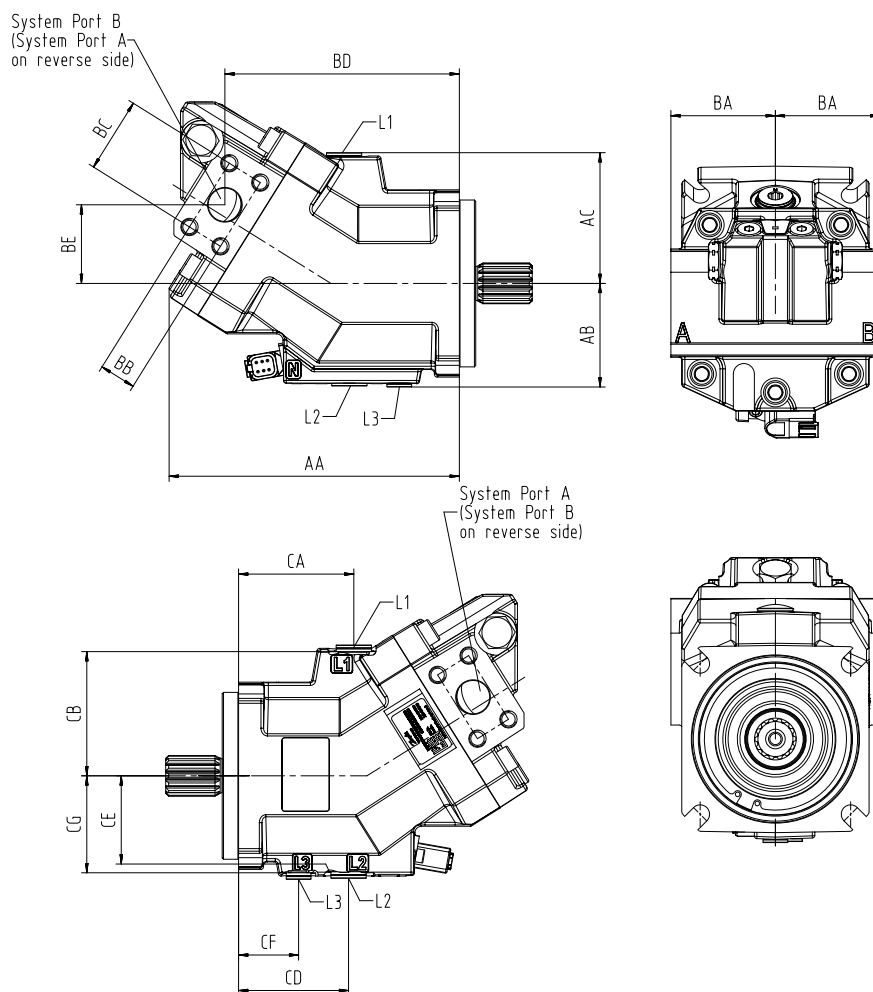

Side ports dimensions, mm [in]

Callout	060	Size 080	110
AA	200.25 [7.884]	220.8 [8.692]	250.9 [9.878]
AB	76.7 [3.020]	78.8 [3.102]	100 [3.937]
AC	126.57 [4.983]	138.1 [5.437]	151.18 [5.952]
BA	71.0 [2.795]	79.5 [3.130]	79.5 [3.130]
BB	23.8 [0.937]	27.8 [1.094]	31.8 [1.252]
BC	50.8 [2.000]	57.2 [2.252]	66.6 [2.622]
BD	164.84 [6.490]	178.4 [7.023]	205.65 [8.096]
BE	52.57 [2.070]	59.9 [2.358]	64.77 [2.550]
CA	79.5 [3.130]	87.7 [3.453]	99.57 [3.920]
CB	84.55 [3.329]	94.5 [3.720]	96.5 [3.799]
CD	80.3 [3.161]	83.7 [3.295]	95.57 [3.762]
CE	68.85 [2.710]	73.0 [2.874]	85.0 [3.346]

Side ports dimensions, mm [in] (continued)

Callout	060	Size 080	110
CF	41.2 [1.622]	45.7 [1.799]	52.27 [2.058]
CG	71.75 [2.825]	73.8 [2.906]	85.8 [3.378]

H1F SAE flange design ports per ISO 6149-1

Ports dimensions per ISO 6149-1; mm [in]

Ports		Size 060	Size 080	Size 110
L1, L2 Case drain	Metric	M22x1.5; Ø44 [1.732]		M27x2.0
L3 Case drain	Metric	M14x1.5; Ø 26 [1.024]		
A, B Split flange boss system		DN 19 (Ø19 mm) M12x1.75; 24 [0.94]	DN 25 (Ø25.4 mm) M12x1.75; 24 [0.94]	DN 32 (Ø31.5 mm) M12x1.75; 23 [0.91]

H1F SAE mounting flange design per ISO 3019/1

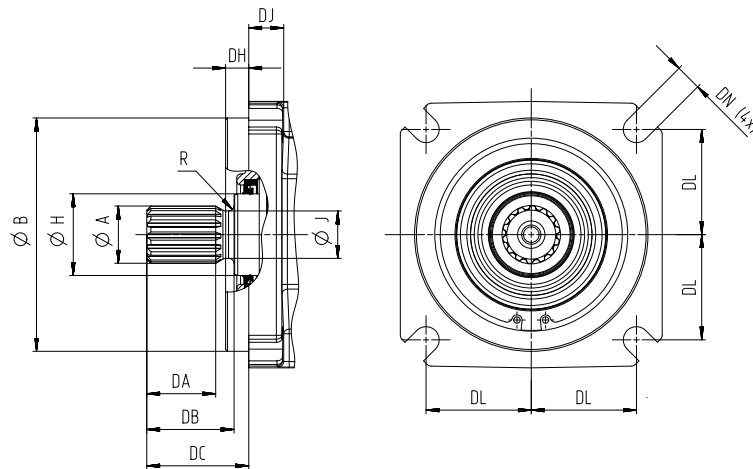

SAE flange dimensions mm [in]

Measure	Size 060	Size 080	Size 110
ØB	126.975 [4.999]	126.975 [4.999]	152.375 [5.999]
DH	12.5 [0.492]	12.5 [0.492]	12.5 [0.492]
DJ	18.3 [0.720]	19 [0.748]	22.3 [0.878]
DL	57.3 [2.256]	57.3 [2.256]	80.8 [3.181]
DN	14.3 [0.563]	14.3 [0.563]	20.6 [0.811]

Shaft options overview (Number of teeth)

Size	AN/AS (14T)	BN/BS (21T)	CN/CS (23T)	DN/DS (27T)	EN/ES (13T)
060	●	●	-	-	-
080	●	●	●	-	-
110	-	-	-	●	●

● = available option, - = not available option

Shaft dimensions; mm [in]

Shaft option	AN/AS	BN/BS	CN/CS	DN/DS	EN/ES
Teeth	14	21	23	27	13
Module	12/24	16/32	16/32	16/32	8/16
Pitch-Ø	29.633 [1.167]	33.337 [1.312]	36.513 [1.438]	42.862 [1.687]	41.275 [1.625]
Spline	ANSI B92.1-1970 Class 5 flat root side fit				
ØA	31.2 [1.228]	34.4 [1.315]	37.61 [1.48]	43.96 [1.731]	43.64 [1.718]
ØH	44.5 [1.752]	44.5 [1.752]	44.5 [1.752]	55.0 [2.165]	55.0 [2.165]
ØJ	25.8 [1.016]	30.0 [1.181]	32.0 [1.260]	39.6 [1.559]	36.0 [1.417]
DA	37.5 [1.476]	37.5 [1.476]	37.5 [1.476]	55.0 [2.165]	55.0 [2.165]
DB	47.5 [1.870]	47.5 [1.870]	47.5 [1.870]	67.0 [2.638]	67.0 [2.638]
DC	55.5 [2.185]	55.5 [2.185]	55.5 [2.185]	75.0 [2.953]	75.0 [2.953]
R	3.0 [0.118]	3.0 [0.118]	3.0 [0.118]	3.0 [0.118]	3.0 [0.118]
Angle	Pressure angle 30°				

 **Note**

For DIN 5480 shaft used in combination with SAE flanges, please contact your local Danfoss Power Solutions representative.

H1F DIN flange design

Axial ports

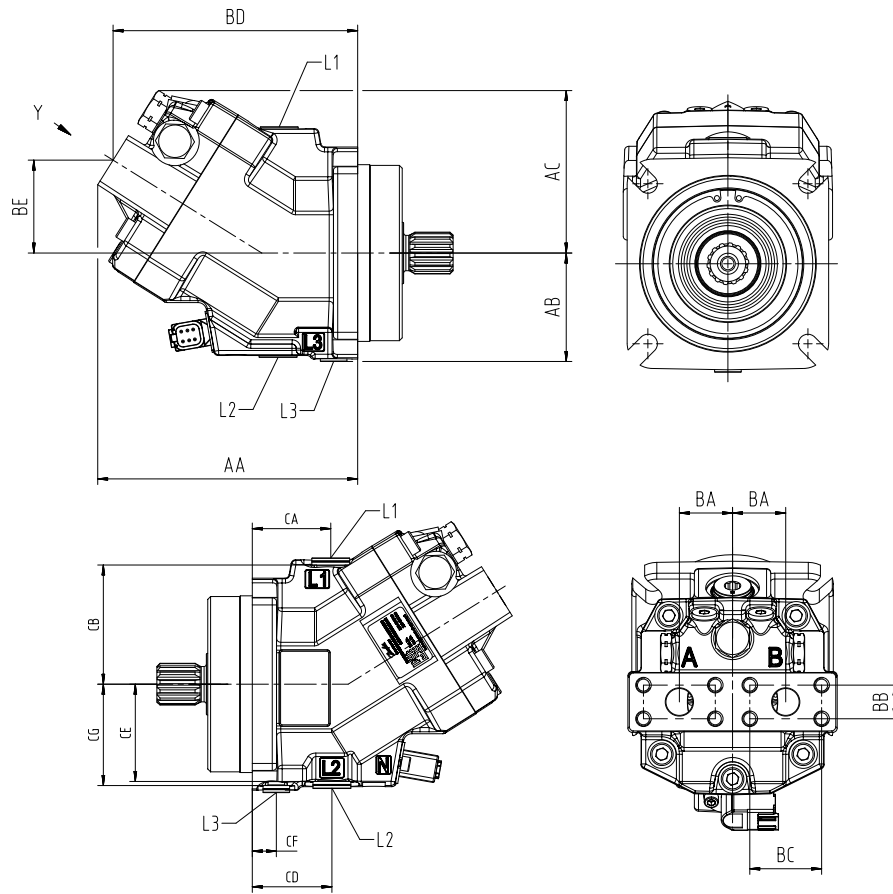

Axial ports dimensions, mm [in]

Callout	Size 060	Size 080	Size 110
AA	204.6 [8.056]	199.2 [7.842]	238.9 [9.405]
AB	76.7 [3.020]	85.0 [3.346]	97.0 [3.819]
AC	106.8 [4.205]	118.8 [4.677]	132.8 [5.228]
BA	37.5 [1.476]	42.0 [1.654]	49.5 [1.949]
BB	23.8 [0.937]	27.8 [1.0944]	31.8 [1.252]
BC	50.8 [2.000]	57.2 [2.252]	66.6 [2.622]
BD	155.3 [6.113]	172.2 [6.780]	184.3 [7.256]
BE	97.4 [3.83]	109.1 [4.295]	115.3 [4.539]
CA	55.5 [2.185]	63.7 [2.508]	67.1 [2.642]
CB	84.3 [3.319]	94.5 [3.720]	96.5 [3.800]
CD	56.3 [2.217]	59.7 [2.350]	63.1 [2.484]
CE	68.8 [2.709]	73.0 [2.874]	86.5 [3.406]
CF	17.0 [0.669]	21.7 [0.854]	19.8 [0.780]
CG	71.7 [2.822]	80.0 [3.150]	92.0 [3.622]

Side ports

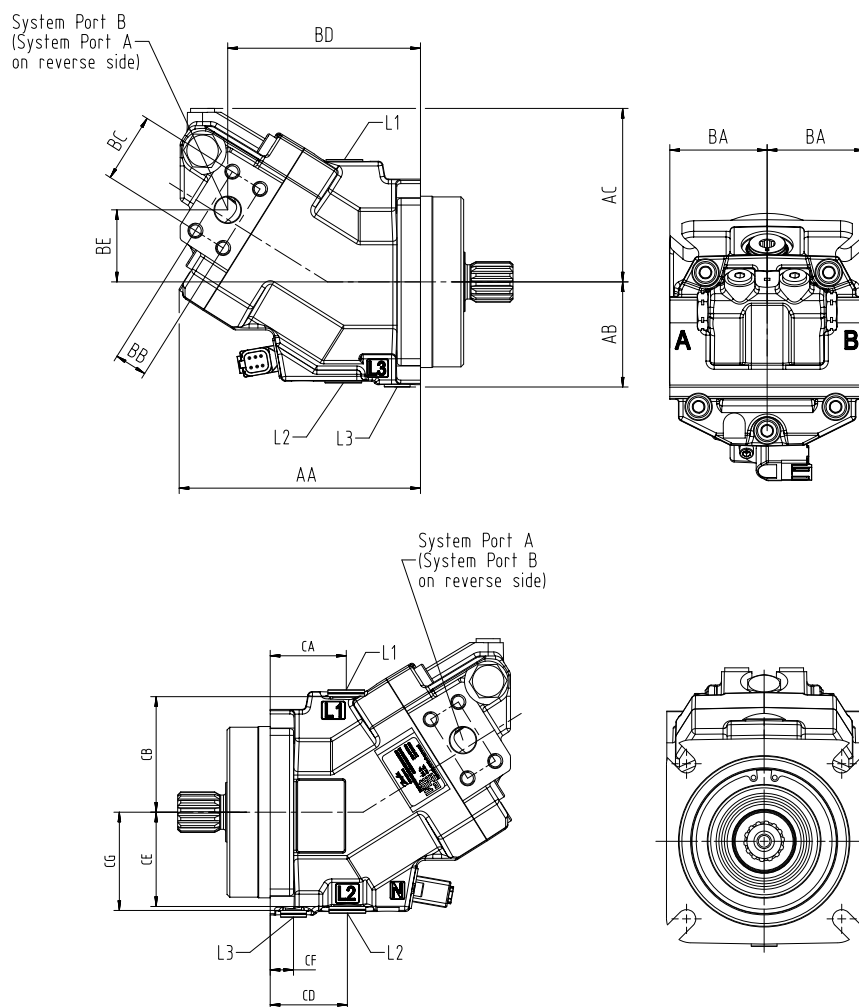

Side ports dimensions, mm [in]

Callout	Size 060	Size 080	Size 110
AA	176.0 [6.929]	196.8 [7.748]	217.1 [8.547]
AB	76.7 [3.020]	85.0 [3.346]	97.0 [3.819]
AC	126.6 [4.983]	138.1 [5.437]	151.2 [5.933]
BA	71.0 [2.795]	79.5 [3.130]	79.5 [3.130]
BB	23.8 [0.937]	27.8 [1.094]	31.8 [1.252]
BC	50.8 [2.000]	57.2 [2.252]	66.6 [2.622]
BD	140.62 [5.536]	154.5 [6.082]	173.2 [6.819]
BE	52.6 [2.070]	59.9 [2.358]	64.8 [2.551]
CA	55.5 [2.185]	63.7 [2.508]	67.1 [2.642]
CB	84.3 [3.319]	94.5 [3.720]	96.5 [3.800]
CD	56.3 [2.217]	59.7 [2.350]	63.1 [2.484]
CE	68.8 [2.709]	73.0 [2.874]	86.5 [3.406]
CF	17.0 [0.669]	21.7 [0.854]	19.8 [0.780]
CG	71.7 [2.822]	80.0 [3.150]	92.0 [3.622]

Twin ports

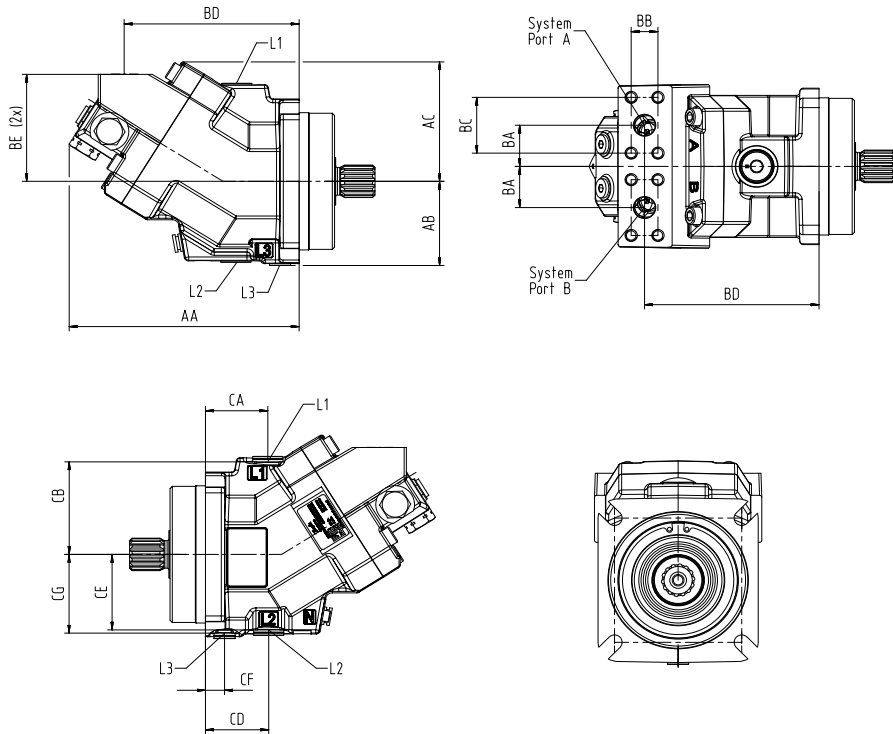

Twin ports dimensions, mm [in]

Callout	Size 060	Size 110
AA	204.6 [8.056]	238.9 [9.405]
AB	76.7 [3.020]	97.0 [3.819]
AC	106.8 [4.205]	132.8 [5.228]
BA	37.5 [1.476]	49.5 [1.949]
BB	23.8 [0.937]	31.8 [1.252]
BC	50.8 [2.000]	66.6 [2.622]
BD	155.3 [6.113]	184.3 [7.256]
BE	97.4 [3.83]	115.3 [4.539]
CA	55.5 [2.185]	67.1 [2.642]
CB	84.3 [3.319]	96.5 [3.800]
CD	56.3 [2.217]	63.1 [2.484]
CE	68.8 [2.709]	86.5 [3.406]
CF	17.0 [0.669]	19.8 [.780]
CG	71.7 [2.822]	92.0 [3.622]

H1F DIN flange design ports per 6149-1

Ports dimensions per ISO 6149-1; mm [in]

Ports	Size 060	Size 080	Size 110
L1, L2 Case drain	M22x1.5		M27x2.0
L3 Case drain	M14x1.5; Ø 26 [1.024]		
A, B Split flange boss system	DN 19 (Ø19 mm) M10x1.5; 18 [0.71]	DN 25 (Ø25.4 mm) M12x1.75; 24 [0.94]	DN 32 (Ø31.5 mm) M12x1.75; 23 [0.91]

H1F DIN mounting flange design per ISO 3019/2

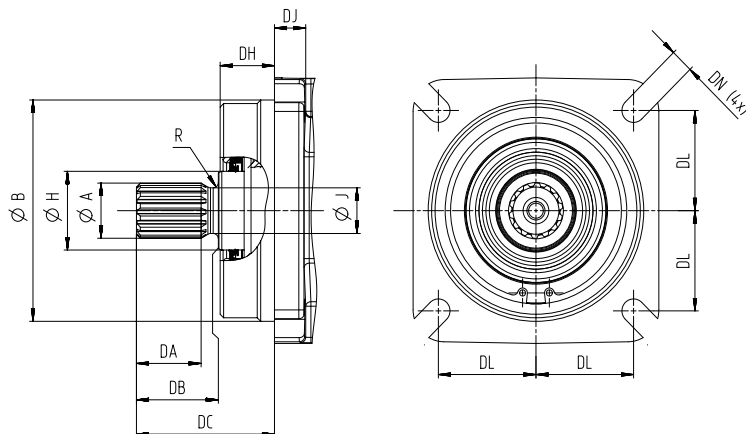

DIN mounting flange per ISO 3019/2 dimensions, mm [in]

Code	Size 060 125 B4 HL	Size 080 140 B4 HL	Size 110 160 B4 HL
ØB	125.0 [4.921]	140.0 [5.512]	160.0 [6.299]
DH	11.2 [0.441]	11.1 [0.437]	10.8 [0.425]
DJ	17.0 [0.669]	19.0 [0.748]	22.2 [0.874]
DL	56.6 [2.228]	63.7 [2.509]	70.7 [2.783]
DN	13.5 [0.531]	13.5 [0.531]	17.5 [0.689]

Shaft options overview

Size	Shaft option (Number of teeth)			
	GN/GS (14T)	HN/HS (16T)	JN/JS (18T)	KN/KS (21T)
060	●	●	-	-
080	-	●	●	-
110	-	-	●	●

● = available option, - = not available option

H1F Cartridge flange design

Side ports

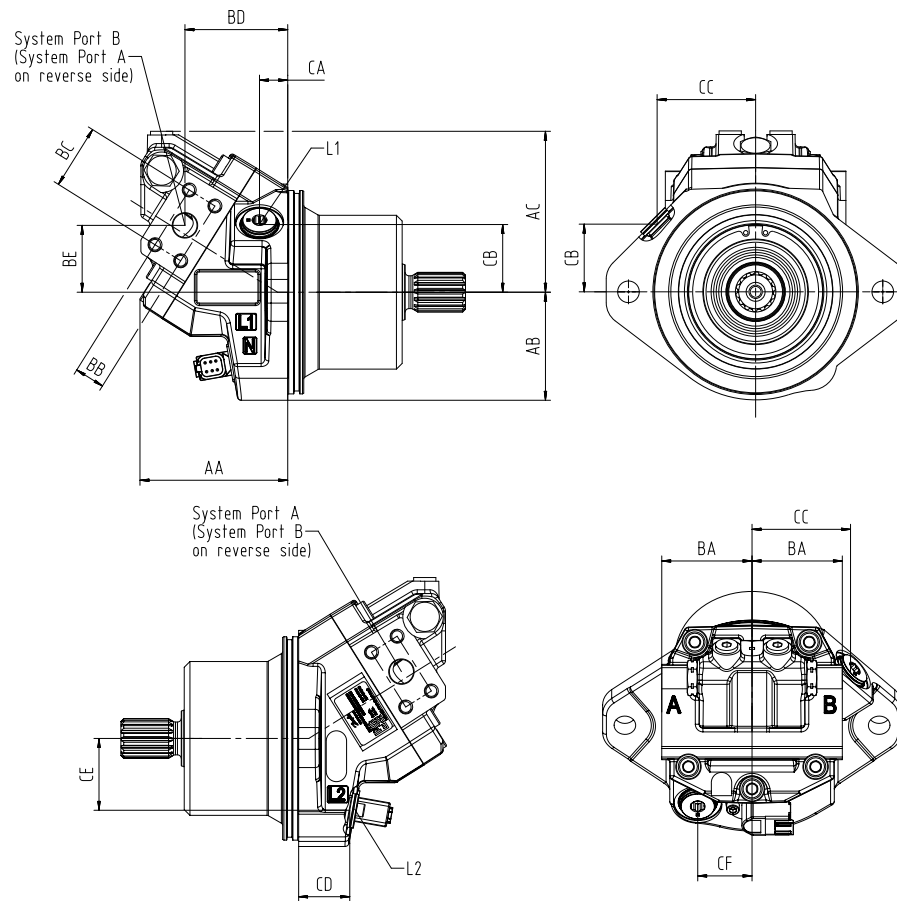

Side ports dimensions, mm [in]

Callout	Size 060	080	110
AA	116.1 [4.571]	118.5 [4.665]	136.6 [5.378]
AB	85.0 [3.346]	98.0 [3.858]	85.5 [3.366]
AC	126.6 [4.983]	138.1 [5.437]	151.2 [5.953]
BA	71.0 [2.795]	79.5 [3.130]	79.5 [3.130]
BB	23.8 [0.937]	27.8 [1.094]	31.8 [1.252]
BC	50.8 [2.000]	57.2 [2.252]	66.6 [2.622]
BD	80.7 [3.177]	76.0 [2.992]	91.4 [3.598]
BE	52.6 [2.070]	59.9 [2.358]	64.8 [2.551]
CA	22.2 [0.874]	21.3 [0.839]	30.3 [1.192]
CB	53.2 [2.096]	49.5 [1.950]	48.0 [1.890]
CD	40.2 [1.583]	27.6 [1.087]	27.8 [1.094]
CE	56.5 [2.224]	57.0 [2.244]	67.3 [2.650]

Twin ports

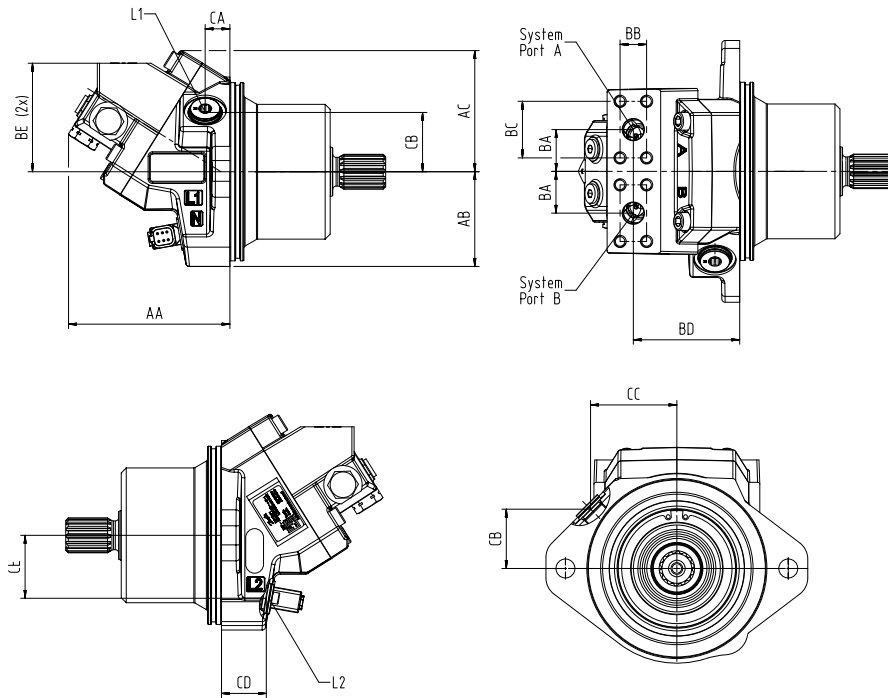

Twin ports dimensions, mm [in]

Callout	Size 060	Size 080	110
AA	144.8 [5.700]	143.5 [5.650]	157.1 [6.185]
AB	85.0 [3.346]	98.0 [3.858]	85.5 [3.367]
AC	106.8 [4.205]	118.8 [4.677]	132.8 [5.228]
BA	37.5 [1.476]	42.0 [1.654]	49.5 [1.949]
BB	23.8 [0.937]	27.8 [1.094]	31.8 [1.252]
BC	50.8 [2.000]	57.2 [2.252]	66.6 [2.622]
BD	95.4 [3.757]	93.8 [3.693]	102.8 [4.047]
BE	97.4 [3.83]	109.1 [4.295]	115.3 [4.539]
CA	22.2 [0.874]	21.3 [0.839]	30.3 [1.193]
CB	53.2 [2.096]	49.5 [1.949]	48 [1.890]
CD	40.2 [1.583]	27.6 [1.087]	27.8 [1.094]
CE	56.5 [2.224]	57.0 [2.244]	67.3 [2.650]

H1F Cartridge flange design ports per ISO 6149-1

Ports dimensions per ISO 6149-1; mm [in]

Ports	Size 060	Size 080	Size 110
L1, L2 Case drain	M22x1.5		M27x2.0
A, B Split flange boss system	DN 19 (Ø19 mm) ²⁾ M10x1.5; 18 [0.71]	DN 25 (Ø25 mm) M12x1.75; 23 [0.91]	DN 32 (Ø31.5 mm) M12x1.75; 23 [0.91]

²⁾ Typ 1, 40 MPa series per ISO 6162. Full thread depth.

H1F Cartridge mounting flange design

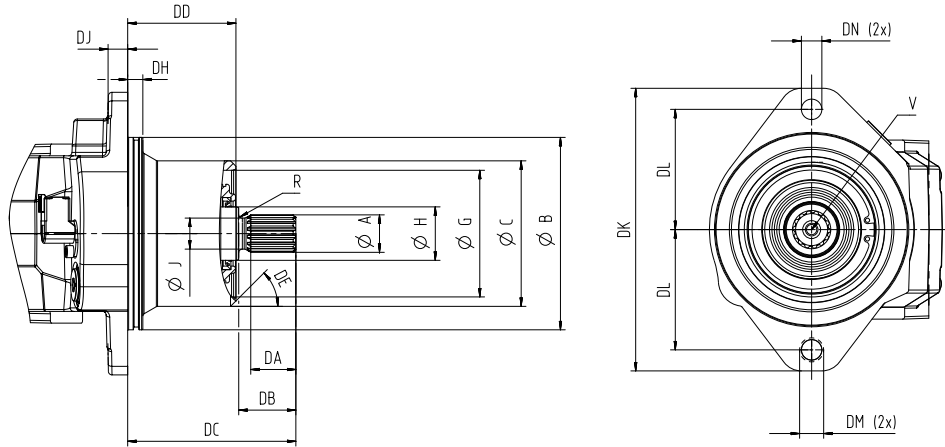

Cartridge flange dimensions, mm [in]

Measure	Size 060	Size 080	Size 110
ØB	160.0 [6.299]	190.0 [7.480]	200.0 [7.874]
ØC	121.0 [4.764]	134.5 [5.295]	150.0 [5.905]
ØG	105.3 [4.146]	115.3 [4.539]	130.3 [5.130]
DE	45°	45°	70°
DD	90.0 [3.543]	109.2 [4.299]	121.0 [4.764]
DH	12.6 [0.496]	11.2 [0.441]	18.0 [0.709]
DJ	16.2 [0.638]	19.5 [0.768]	17.6 [0.693]
DK	235.0 [9.252]	260.0 [10.236]	286.0 [11.260]
DL	100.0 [3.937]	112.0 [4.409]	125.0 [4.921]
DM	30.0 [1.181]	40.0 [1.575]	35.0 [1.378]
DN	17.0 [0.669]	21.0 [0.827]	21.0 [0.827]

 **Note**

Motor installations will vary by application. It is the customer's responsibility to evaluate each application for proper mounting and sealing.

Frame size 060 and 080 shaft options

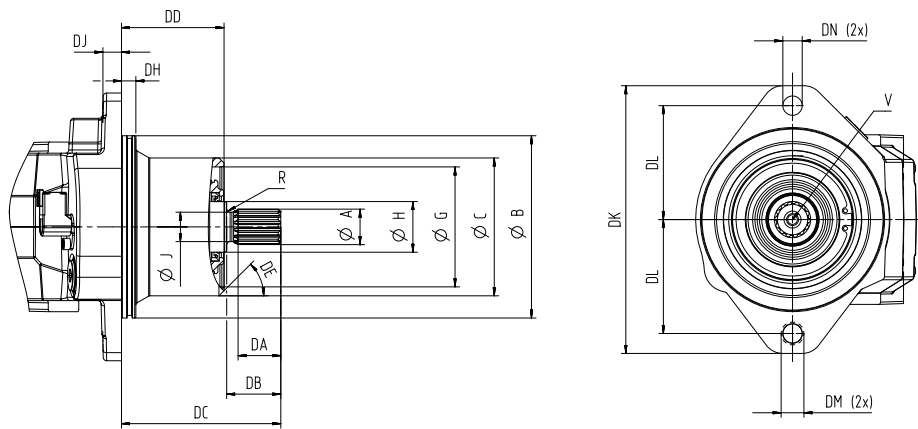

Shaft dimensions for frame size 060, mm [in]

Option	AN/AS	BN/BS	GN/GS	HN/HS
Teeth	14	21	14	16
Pitch-Ø	29.633 [1.167]	33.337 [1.312]	28.0 [1.102]	32.0 [1.260]
Spline*	ANSI B92.1-1970 Class 5 flat root side fit		W30x2x30x14x9g	W35x2x30x16x9g
A	34.4 [1.315]	34.4 [1.315]	29.6 [1.165]	34.6 [1.362]
ØH	44.5 [1.752]	44.5 [1.752]	44.5 [1.752]	44.5 [1.752]
ØJ	25.8 [1.016]	30.0 [1.181]	25.0 [0.984]	30.0 [1.181]
DA	37.5 [1.476]	37.5 [1.476]	27.0 [1.063]	32.0 [1.260]
DB	47.5 [1.87]	47.5 [1.87]	35.0 [1.378]	40.0 [1.575]
DC (060)	139.7 [5.500]	139.7 [5.500]	127.2 [5.008]	132.2 [5.205]
DC (080)	157.9 [6.217]	157.9 [6.217]	—	150.4 [5.921]
R	3.0 [0.118]	3.0 [0.118]	1.6 [0.063]	1.6 [0.063]
V	M10	M10	M10	M10
Angle	Pressure angle 30°			

* Spline per DIN 5480, side fit.

Shaft options overview for frame size 060

Size	Shaft option			
	AN/AS	BN/BS	GN/GS	HN/HS
060	●	●	●	●

● = available option; — = not available option



Hydro-Gear

www.hydro-gear.com

Daikin-Sauer-Danfoss

www.daikin-sauer-danfoss.com

Explore our solutions at danfoss.com.

Additional product literature is available at powersource.danfoss.com.

**Danfoss
Power Solutions (US) Company**
2800 East 13th Street
Ames, IA 50010, USA
Phone: +1 515 239 6000

**Danfoss
Power Solutions GmbH & Co. OHG**
Krokamp 35
D-24539 Neumünster, Germany
Phone: +49 4321 871 0

**Danfoss
Power Solutions ApS**
Nordborgvej 81
DK-6430 Nordborg, Denmark
Phone: +45 7488 2222

**Danfoss
Power Solutions Trading
(Shanghai) Co., Ltd.**
Building #22, No. 1000 Jin Hai Rd
Jin Qiao, Pudong New District
Shanghai, China 201206
Phone: +86 21 2080 6201

Danfoss can accept no responsibility for possible errors in catalogues, brochures and other printed material. Danfoss reserves the right to alter its products without notice. This also applies to products already on order provided that such alterations can be made without subsequent changes being necessary in specifications already agreed.
All trademarks in this material are property of the respective companies. Danfoss and the Danfoss logotype are trademarks of Danfoss A/S. All rights reserved.
