

Manual balancing

MSV-BD Manual Presetting Valves LENO™

Description

LENO™ MSV-BD is a range of manual valves for balancing flow in heating and cooling systems.

It is recommended to use LENO™ MSV-BD in constant flow systems. The valve may be mounted in flow or return.

MSV-BD PURE valves are available in DN15LF - 25 range. The only difference between MSV-BD and MSV-BD PURE valves is the brass material used for valve construction.

Features & benefits

- Removable hand wheel for easy mounting.
- 360° turnable measuring station for convenient measuring and draining.
- Numeric presetting scale, visible from more angles.
- Easy locking of presetting.
- Built-in test plugs for Ø 3 mm needles.
- Drain connection with separate draining of inlet and outlet side of valve.
- Open-close with Allen key for extra force.
- Open-closed colour indicator.

Applications

Boiler, flat station or heat pump in 1-family houses

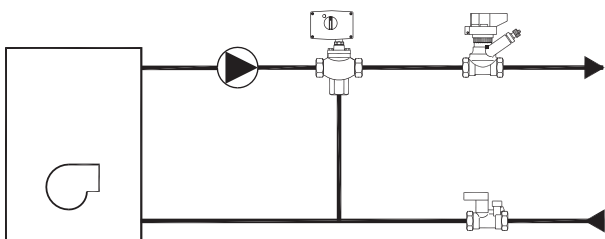

- For balancing.
- Shut-off function for service/repair.

Air handling unit

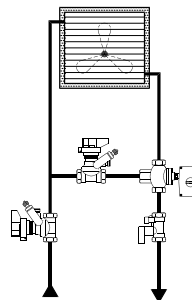

- For constant flow.
- For balancing.
- Shut-off function for service/repair.

Fan coils

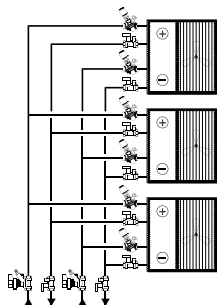

- For flow verification.
- Shut-off function for service/repair.

1-pipe system

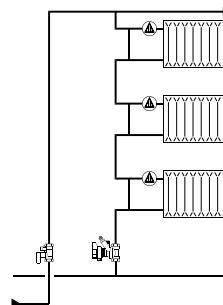

- For balancing.
- Shut-off function for service/repair

DOMESTIC HOT WATER SYSTEMS: Depending on local legislation it can be used in Domestic hot water applications.

Ordering

Product code numbers













Description	Kvs values [m ³ /h]	Connection types	Connections	Code number	VVS DK
MSV-BD DN 15 Low flow, Internal thread, manual balancing valve	2.50	Internal thread ISO 228/1	G ½"	003Z4000	406948004
MSV-BD DN 15, Internal thread, manual balancing valve	3.00	Internal thread ISO 228/1	G ½"	003Z4001	406948104
MSV-BD DN 20, Internal thread, manual balancing valve	6.00	Internal thread ISO 228/1	G ¾"	003Z4002	406948106
MSV-BD DN 25, Internal thread, manual balancing valve	9.50	Internal thread ISO 228/1	G 1"	003Z4003	406948108
MSV-BD DN 32, Internal thread, manual balancing valve	18.00	Internal thread ISO 228/1	G 1 ¼"	003Z4004	406948110
MSV-BD DN 40, Internal thread, manual balancing valve	26.00	Internal thread ISO 228/1	G 1 ½"	003Z4005	406948111
MSV-BD DN 50, Internal thread, manual balancing valve	40.00	Internal thread ISO 228/1	G 2"	003Z4006	406948112
Set of MSV-BD and MSV-S DN 15, Internal thread	3	Internal thread ISO 228/1	G ½"	003Z4051	
Set of MSV-BD and MSV-S DN 20, Internal thread	6	Internal thread ISO 228/1	G ¾"	003Z4052	
Set of MSV-BD and MSV-S DN 25, Internal thread	9.5	Internal thread ISO 228/1	G 1"	003Z4053	
Set of MSV-BD and MSV-S DN 32, Internal thread	18	Internal thread ISO 228/1	G 1 ¼"	003Z4054	
Set of MSV-BD and MSV-S DN 40, Internal thread	26	Internal thread ISO 228/1	G 1 ½"	003Z4055	
Set of MSV-BD and MSV-S DN 50, Internal thread	40	Internal thread ISO 228/1	G 2"	003Z4056	
MSV-BD DN 15, External thread, manual balancing valve	3.00	External thread ISO 228/1	G ¾"	003Z4101	406948134
MSV-BD DN 20, External thread, manual balancing valve	6.00	External thread ISO 228/1	G 1 A	003Z4102	406948136
MSV-BD PURE DN15 LF G½"	2.50	Internal thread	G ½"	003Z9990	406948204
MSV-BD PURE DN15 G½"	3.00	Internal thread	G ½"	003Z9991	406948304
MSV-BD PURE DN20 G¾"	6.00	Internal thread	G ¾"	003Z9992	406948306
MSV-BD PURE DN25 G1"	9.50	Internal thread	G 1"	003Z9993	406948308

DZR brass: Corrosion resistant brass.

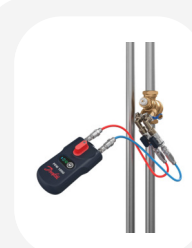
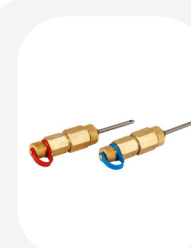
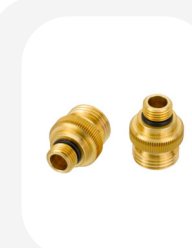
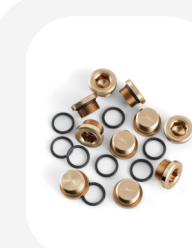
Drain flow is measured at 1 bar static pressure and 0.1 bar differential pressure.



Accessories code numbers

 <p>003Z8261</p> <p>PFM 1000, 20 bar</p> <p>PFM 1000, 20 bar, measuring instrument for balancing cooling, heating and domestic hot water systems.</p>	 <p>003Z4097</p> <p>Drain connection 3/4" with O-ring</p> <p>Drain connection 3/4" with O-ring</p>	 <p>003Z4662</p> <p>Set of standard test plugs, 3 mm (2 pcs.)</p> <p>Set of standard test plugs, 3 mm (2 pcs.)</p>	 <p>003Z4660</p> <p>Identification tag and strips (10 pcs.)</p> <p>Identification tag and strips (10 pcs.)</p>	 <p>003Z4652</p> <p>Operating handle DN 15 - 50</p> <p>Operating handle DN 15 - 50</p>
 <p>003Z4782</p> <p>Insulation cap MSV / ASV-BD DN 20</p> <p>Insulation cap MSV / ASV-BD DN 20</p>	 <p>003Z8260</p> <p>PFM 1000, 10 bar</p> <p>PFM 1000, 10 bar, measuring instrument for balancing cooling, heating and domestic hot water systems.</p>	 <p>003Z3946</p> <p>Set of extended test plugs, needle type (2 pcs., blue + red)</p> <p>Set of extended test plugs, needle type (2 pcs., blue + red)</p>	 <p>003Z4096</p> <p>Drain connection 1/2" with O-ring</p> <p>Drain connection 1/2" with O-ring</p>	 <p>003Z9900</p> <p>MSV-BD Drain plug PURE, less than 0,1% lead</p> <p>MSV-BD Drain plug PURE, less than 0,1% lead</p>
 <p>003Z4781</p> <p>Insulation cap MSV / ASV-BD DN 15</p> <p>Insulation cap MSV / ASV-BD DN 15</p>	 <p>003Z4783</p> <p>Insulation cap MSV / ASV-BD DN 25</p> <p>Insulation cap MSV / ASV-BD DN 25</p>	 <p>003Z4786</p> <p>Insulation cap MSV / ASV-BD DN 50</p> <p>Insulation cap MSV / ASV-BD DN 50</p>	 <p>003Z4784</p> <p>Insulation cap MSV / ASV-BD DN 32</p> <p>Insulation cap MSV / ASV-BD DN 32</p>	 <p>003Z4785</p> <p>Insulation cap MSV / ASV-BD DN 40</p> <p>Insulation cap MSV / ASV-BD DN 40</p>

Spare parts code numbers



003Z4652

Operating handle DN 15 - 50

Operating handle DN 15 - 50



003Z9900

MSV-BD Drain plug PURE, less than 0,1% lead

MSV-BD Drain plug PURE, less than 0,1% lead

Functions

Operation

Shut-off

In order to shut-off the valve the handle must be pressed down.
The shut-off function features a ball valve, which only requires a 90 degree turn to shut the valve completely.
An indicator window shows the actual setting:

red = closed
white = open

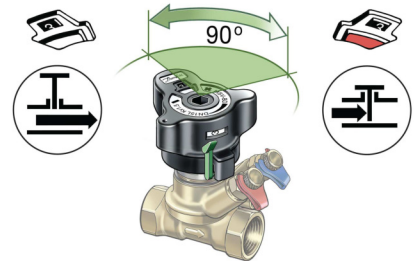

Draining

Note! The drain connection is an accessory and must be purchased separately.

The drain tap can rotate 360 degrees for convenient operation.

Draining the system pipes can be done selectively:

When the red test plug is opened, the valve inlet pipe is drained.
Opening the blue test plug will drain the pipe on the valve outlet side. Test plugs unscrewing protection screw is located between valve test plugs.

Note: The PURE version has left-handed (reverse) threads. Meaning it should be turned clockwise for draining.

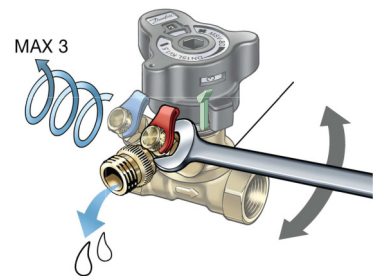

Measuring

The flow through the LENO™ MSV-BD valve can be measured using Danfoss PFM 1000 or other brands of measuring instruments.

The LENO™ MSV-BD valve is supplied with two test plugs for Ø3 mm needles.
A twin bracket enables the user to connect both needles simultaneously.

Procedure for flow measuring:

1. Select flow measuring.
2. Select valve brand.
3. Select valve type and dimension.
4. Enter presetting.
5. Connect valve and instrument.
6. Calibrate static pressure.
7. Measure the flow.

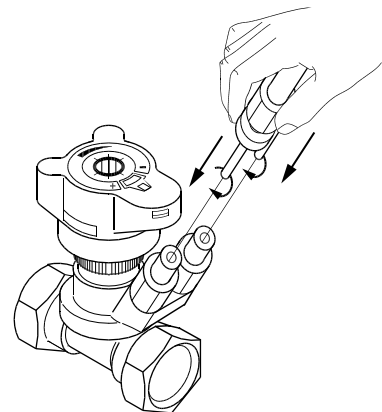

Measuring accuracy

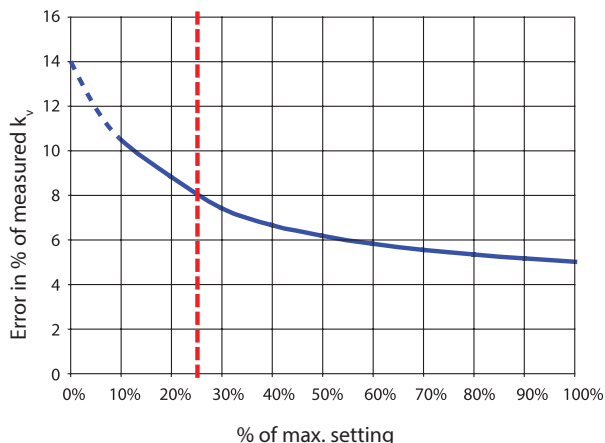

LENO™ MSV-BD is very accurate, due to the separate functions for presetting and shut-off. Valve can be mounted everywhere in the system (closed to T-pieces, elbows, pumps, etc.), since it is unaffected by turbulence in any setting or installation.

The red line indicates 25% of max. flow. According to BS7350:1990 flow rates must be within following values:
 ± 18% at 25% open position
 ± 10% at fully open position

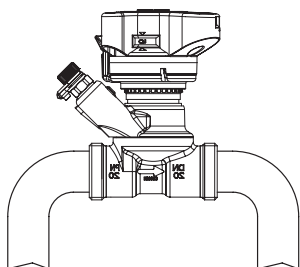

K_v -signal

K_v -signal values are used for non-Danfoss measuring instruments. Danfoss PFM 1000 have all data in memory, and the instruments are using this formula:

$$\Delta P_{val} = \Delta P_{sig} = \left(\frac{k_{v, sig}}{k_{v, val}} \right)^2$$

Δp across the test plugs (k_v -sig) and Δp across the valve (k_v -val) is not the same due to turbulence influence for pressure measuring.

Setting	DN 15LF	DN 15	DN 20	DN 25	DN 32	DN 40	DN 50
0.0	0.07	0.10	0.12	0.34	0.51	1.05	1.75
0.1	0.08	0.11	0.16	0.44	0.73	1.20	2.01
0.2	0.09	0.12	0.20	0.53	0.92	1.36	2.25
0.3	0.11	0.13	0.26	0.61	1.10	1.55	2.47
0.4	0.12	0.14	0.32	0.67	1.26	1.74	2.69
0.5	0.13	0.16	0.38	0.73	1.43	1.95	2.91
0.6	0.15	0.19	0.45	0.79	1.60	2.17	3.12
0.7	0.16	0.21	0.53	0.84	1.78	2.40	3.35
0.8	0.17	0.24	0.60	0.90	1.97	2.64	3.58
0.9	0.19	0.26	0.67	0.95	2.18	2.88	3.82
1.0	0.20	0.29	0.74	1.01	2.39	3.13	4.07

Setting	DN 15LF	DN 15	DN 20	DN 25	DN 32	DN 40	DN 50
1.1	0.21	0.32	0.82	1.08	2.62	3.39	4.33
1.2	0.23	0.34	0.89	1.14	2.87	3.64	4.60
1.3	0.25	0.37	0.96	1.22	3.12	3.90	4.89
1.4	0.27	0.40	1.03	1.29	3.38	4.16	5.18
1.5	0.30	0.44	1.09	1.37	3.64	4.43	5.49
1.6	0.32	0.47	1.16	1.46	3.92	4.69	5.80
1.7	0.35	0.51	1.23	1.55	4.19	4.96	6.13
1.8	0.37	0.54	1.30	1.65	4.48	5.24	6.46
1.9	0.40	0.58	1.38	1.75	4.76	5.51	6.80
2.0	0.43	0.61	1.45	1.85	5.05	5.80	7.14
2.1	0.46	0.65	1.53	1.96	5.35	6.08	7.49
2.2	0.49	0.69	1.61	2.07	5.65	6.38	7.84
2.3	0.52	0.73	1.69	2.18	5.96	6.68	8.19
2.4	0.56	0.77	1.78	2.29	6.27	6.99	8.55
2.5	0.59	0.80	1.87	2.41	6.60	7.30	8.91
2.6	0.62	0.85	1.97	2.53	6.94	7.63	9.27
2.7	0.66	0.89	2.07	2.65	7.29	7.98	9.64
2.8	0.69	0.93	2.17	2.77	7.67	8.33	10.00
2.9	0.73	0.97	2.29	2.89	8.06	8.70	10.37
3.0	0.76	1.01	2.40	3.01	8.48	9.08	10.74
3.1	0.80	1.04	2.52	3.13	8.92	9.48	11.11
3.2	0.83	1.08	2.65	3.25	9.38	9.90	11.49
3.3	0.87	1.12	2.78	3.37	9.87	10.33	11.88
3.4	0.90	1.16	2.91	3.49	10.38	10.79	12.27
3.5	0.94	1.20	3.05	3.62	10.91	11.26	12.67
3.6	0.97	1.25	3.19	3.74	11.46	11.74	13.09
3.7	1.01	1.30	3.33	3.87	12.02	12.25	13.51
3.8	1.06	1.35	3.47	4.00	12.58	12.77	13.95
3.9	1.10	1.41	3.61	4.13	13.12	13.30	14.41
4.0	1.14	1.47	3.75	4.26	13.64	13.85	14.88
4.1	1.18	1.53	3.89	4.39	14.12	14.41	15.38
4.2	1.23	1.59	4.02	4.53	14.52	14.98	15.89
4.3	1.27	1.66	4.15	4.68	14.84	15.55	16.44

Setting	DN 15LF	DN 15	DN 20	DN 25	DN 32	DN 40	DN 50	
4.4	1.31	1.73	4.28	4.82	-	16.13	17.00	
4.5	1.35	1.81	4.40	4.98		16.69	17.59	
4.6	1.39	1.91	4.52	5.13		17.25	18.21	
4.7	1.43	2.00	4.62	5.29		17.80	18.86	
4.8	1.47	2.08	4.72	5.46		18.32	19.54	
4.9	1.51	2.16	4.82	5.64		18.80	20.24	
5.0	1.54	2.23	4.90	5.81		19.25	20.97	
5.1	1.60	2.30	4.97	6.00		19.65	21.73	
5.2	1.66	2.36	5.04	6.19		19.98	22.51	
5.3	1.72	2.41	-	6.38		20.24	23.30	
5.4	1.79	2.46		6.57		20.41	24.12	
5.5	1.87	2.50		6.77		20.48	24.94	
5.6	1.93	2.54		6.96		-	-	25.76
5.7	1.99	2.57		7.15				26.58
5.8	2.4	-		7.34				27.38
5.9	2.9			7.52				28.16
6.0	2.14			7.69				28.90
6.1	2.18			7.85				29.59
6.2	2.22			7.98				30.21
6.3	2.26		-	-				30.74
6.4	-				31.17			
6.5					31.47			
6.6					31.61			

Correction factors

Medium: Ethylene glycol / propylene glycol percentage (max. 30 %).

Temp. °C	Flow, m ³ /h						
	25	30	40	50	60	65	100
-40.0	1)	1)	1)	1)	0.89	0.88	1)
-17.8	1)	1)	0.93	0.91	0.90	0.89	0.86
4.4	0.95	0.95	0.93	0.92	0.91	0.90	0.87
26.6	0.96	0.95	0.94	0.93	0.92	0.91	0.88
48.9	0.97	0.96	0.95	0.94	0.93	0.92	0.90
71.1	0.98	0.98	0.96	0.95	0.94	0.94	0.95
93.3	1.00	0.99	0.97	0.96	0.95	0.95	0.92
115.6	2)	2)	2)	2)	2)	2)	0.94

1) Below freezing point

2) Above boiling point

Example

Flow needed ... 30 m³/h

Flow after correction ... $30 \times 0.95 = 28 \text{ m}^3/\text{h}$



Flow diagrammes, DN 15 LF

LENO™ MSV-BD DN 15 LF

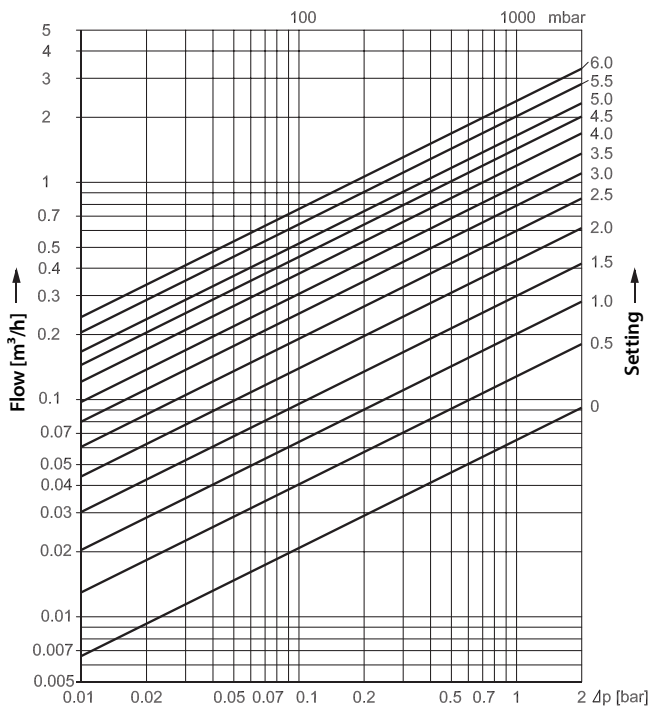

Flow characteristics

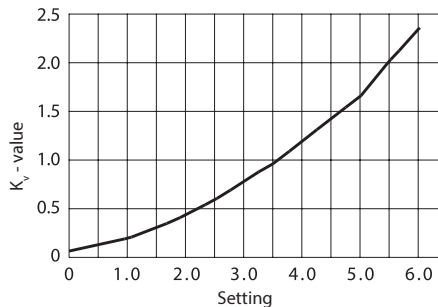

Setting	k_v value	Setting	k_v value	Setting	k_v value
0.0	0.07	2.2	0.50	4.3	1.33
0.1	0.08	2.3	0.53	4.4	1.38
0.2	0.09	2.4	0.56	4.5	1.43
0.3	0.11	2.5	0.60	4.6	1.48
0.4	0.17	2.6	0.63	4.7	1.52
0.5	0.13	2.7	0.67	4.8	1.56
0.6	0.15	2.8	0.71	4.9	1.61
0.7	0.16	2.9	0.74	5.0	1.65
0.8	0.17	3.0	0.78	5.1	1.72
0.9	0.19	3.1	0.82	5.2	1.78
1.0	0.20	3.2	0.86	5.3	1.86
1.1	0.22	3.3	0.89	5.4	1.94
1.2	0.23	3.4	0.93	5.5	2.02
1.3	0.25	3.5	0.97	5.6	2.10
1.4	0.28	3.6	1.01	5.7	2.17
1.5	0.30	3.7	1.05	5.8	2.25
1.6	0.32	3.8	1.10	5.9	2.30
1.7	0.35	3.9	1.15	6.0	2.36
1.8	0.38	4.0	1.19	6.1	2.40
1.9	0.41	4.1	1.24	6.2	2.47
2.0	0.44	4.2	1.29	6.3	2.53
2.1	0.47				



Flow diagrammes, DN 15

LENO™ MSV-BD DN 15

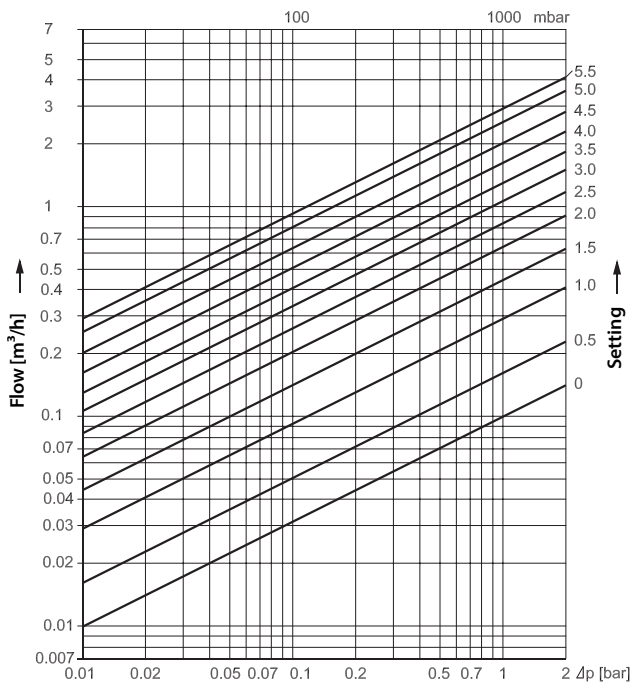

Flow characteristics

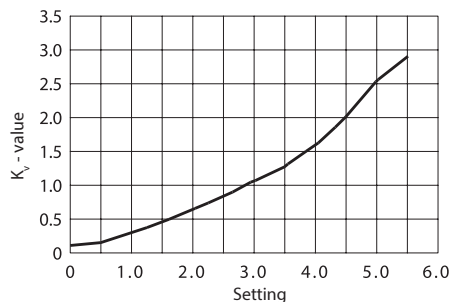

Setting	k _v value	Setting	k _v value	Setting	k _v value
0.0	0.10	2.0	0.63	3.9	1.52
0.1	0.11	2.1	0.67	4.0	1.59
0.2	0.12	2.2	0.71	4.1	1.66
0.3	0.13	2.3	0.75	4.2	1.74
0.4	0.14	2.4	0.80	4.3	1.82
0.5	0.16	2.5	0.84	4.4	1.91
0.6	0.19	2.6	0.88	4.5	2.00
0.7	0.21	2.7	0.93	4.6	2.12
0.8	0.24	2.8	0.97	4.7	2.23
0.9	0.27	2.9	1.02	4.8	2.33
1.0	0.29	3.0	1.06	4.9	2.43
1.1	0.32	3.1	1.10	5.0	2.53
1.2	0.35	3.2	1.14	5.1	2.61
1.3	0.38	3.3	1.19	5.2	2.70
1.4	0.41	3.4	1.23	5.3	2.77
1.5	0.44	3.5	1.28	5.4	2.84
1.6	0.48	3.6	1.34	5.5	2.90
1.7	0.51	3.7	1.40	5.6	2.95
1.8	0.55	3.8	1.46	5.7	3.00
1.9	0.59				

Flow diagrammes, DN 20

LENO™ MSV-BD DN 20

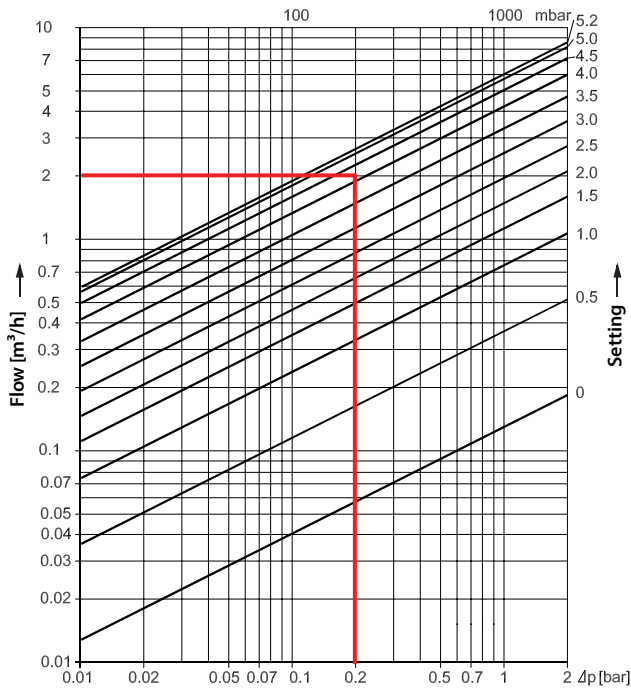

Flow characteristics

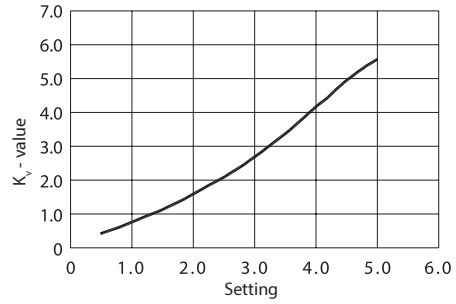

Setting	k_v value	Setting	k_v value	Setting	k_v value
0.0	0.13	1.8	1.35	3.6	3.53
0.1	0.15	1.9	1.43	3.7	3.70
0.2	0.19	2.0	1.50	3.8	3.87
0.3	0.24	2.1	1.59	3.9	4.05
0.4	0.30	2.2	1.67	4.0	4.23
0.5	0.37	2.3	1.76	4.1	4.40
0.6	0.45	2.4	1.86	4.2	4.58
0.7	0.53	2.5	1.96	4.3	4.75
0.8	0.61	2.6	2.07	4.4	4.91
0.9	0.68	2.7	2.19	4.5	5.07
1.0	0.76	2.8	2.31	4.6	5.22
1.1	0.84	2.9	2.44	4.7	5.37
1.2	0.92	3.0	2.58	4.8	5.51
1.3	0.99	3.1	2.72	4.9	5.64
1.4	1.06	3.2	2.87	5.0	5.77
1.5	1.13	3.3	3.03	5.1	5.88
1.6	1.21	3.4	3.19	5.2	6.00
1.7	1.28	3.5	3.36		

Flow diagrammes, DN 25

LENO™ MSV-BD DN 25

Flow characteristics

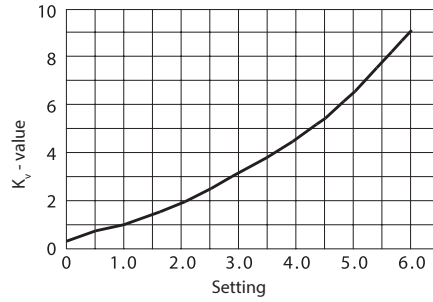
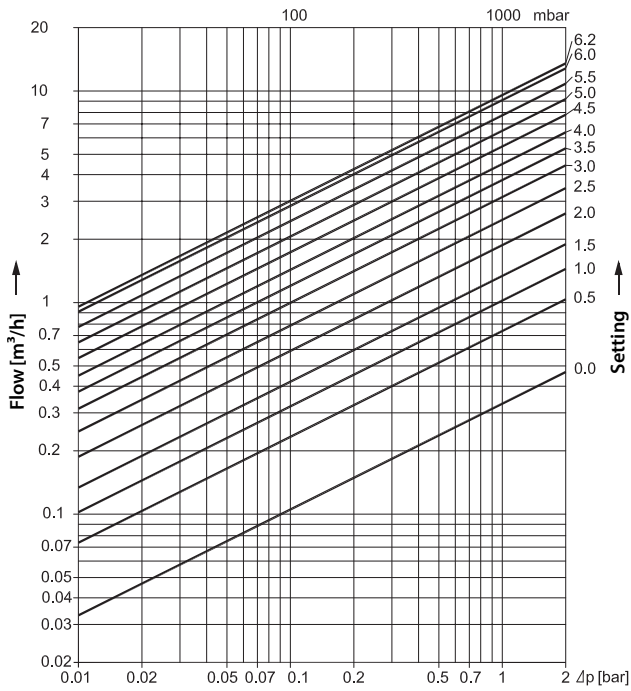

Setting	k_v value	Setting	k_v value	Setting	k_v value
0.0	0.33	2.1	2.03	4.2	4.88
0.1	0.44	2.2	2.15	4.3	5.05
0.2	0.53	2.3	2.26	4.4	5.23
0.3	0.61	2.4	2.29	4.5	5.42
0.4	0.68	2.5	2.51	4.6	5.62
0.5	0.74	2.6	2.64	4.7	5.83
0.6	0.79	2.7	2.76	4.8	6.05
0.7	0.85	2.8	2.89	4.9	6.27
0.8	0.91	2.9	3.02	5.0	6.51
0.9	0.96	3.0	3.15	5.1	6.75
1.0	1.03	3.1	3.28	5.2	7.00
1.1	1.09	3.2	3.41	5.3	7.26
1.2	1.16	3.3	3.54	5.4	7.53
1.3	1.24	3.4	3.68	5.5	7.80
1.4	1.32	3.5	3.81	5.6	8.06
1.5	1.41	3.6	3.95	5.7	8.33
1.6	1.50	3.7	4.09	5.8	8.59
1.7	1.60	3.8	4.24	5.9	8.84
1.8	1.70	3.9	4.39	6.0	9.08
1.9	1.80	4.0	4.55	6.1	9.30
2.0	1.91	4.1	4.71	6.2	9.50
2.1	2.03				



Flow diagrammes, DN 32

LENO™ MSV-BD DN 32

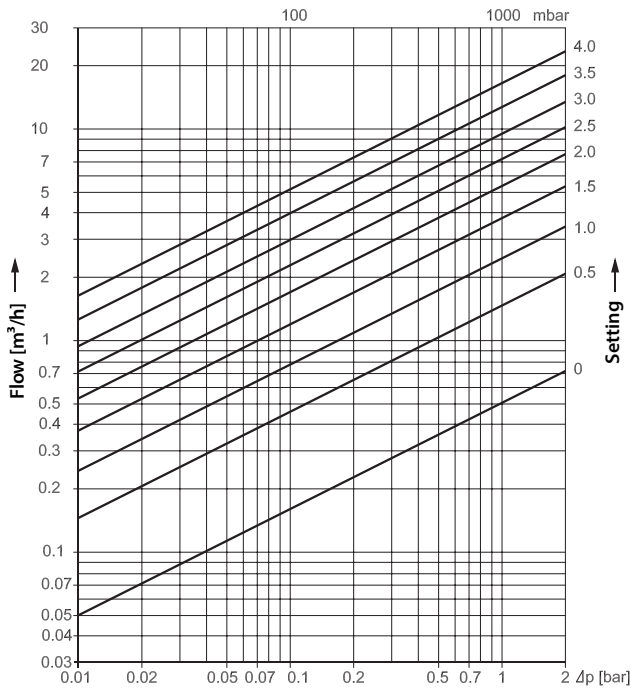

Flow characteristics

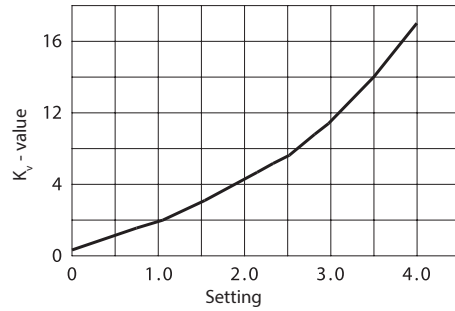

Setting	k_v value	Setting	k_v value	Setting	k_v value
0.0	0.50	1.5	3.75	3.0	9.35
0.1	0.75	1.6	4.05	3.1	9.92
0.2	0.95	1.7	4.36	3.2	10.52
0.3	1.13	1.8	4.67	3.3	11.16
0.4	1.29	1.9	4.98	3.4	11.85
0.5	1.45	2.0	5.30	3.5	12.51
0.6	1.62	2.1	5.63	3.6	13.23
0.7	1.80	2.2	5.97	3.7	13.98
0.8	2.00	2.3	6.32	3.8	14.74
0.9	2.20	2.4	6.68	3.9	15.49
1.0	2.42	2.5	7.06	4.0	16.23
1.1	2.66	2.6	7.46	4.1	16.91
1.2	2.92	2.7	7.89	4.2	17.51
1.3	3.19	2.8	8.34	4.3	18.00
1.4	3.47	2.9	8.83		

Flow diagrammes, DN 40

LENO™ MSV-BD DN 40

Flow characteristics

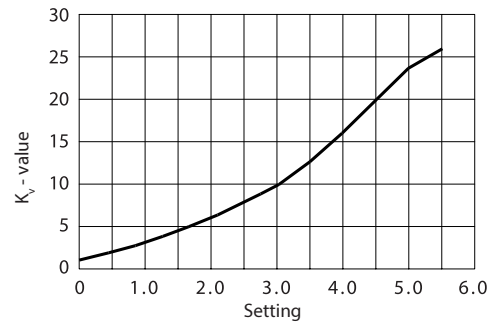
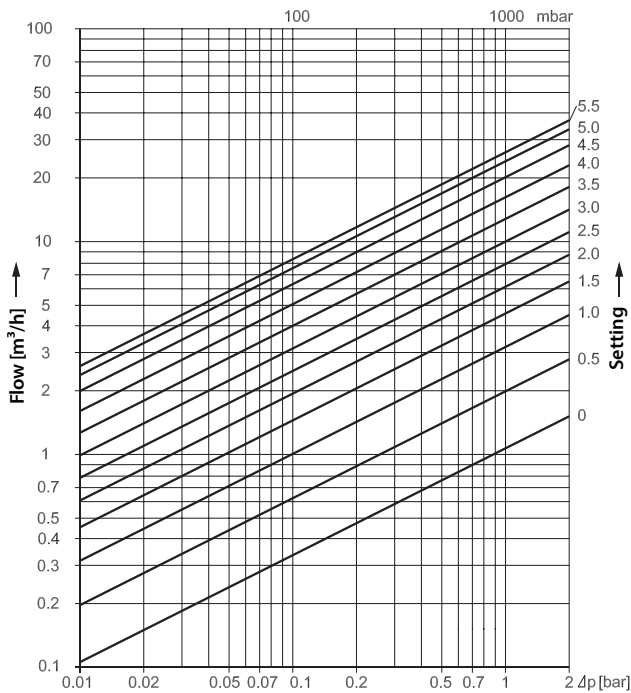

Setting	k_v value	Setting	k_v value	Setting	k_v value
0.0	1.06	2.0	6.09	3.8	14.56
0.1	1.21	2.1	6.41	3.9	15.28
0.2	1.38	2.2	6.74	4.0	16.02
0.3	1.56	2.3	7.09	4.1	16.79
0.4	1.76	2.4	7.44	4.2	17.57
0.5	1.97	2.5	7.80	4.3	18.38
0.6	2.20	2.6	8.18	4.4	19.19
0.7	2.43	2.7	8.58	4.5	20.02
0.8	2.68	2.8	9.00	4.6	20.82
0.9	2.93	2.9	9.44	4.7	21.61
1.0	3.19	3.0	9.90	4.8	22.38
1.1	3.46	3.1	10.38	4.9	23.12
1.2	3.73	3.2	10.89	5.0	23.81
1.3	4.01	3.3	11.43	5.1	24.44
1.4	4.29	3.4	12.00	5.2	25.00
1.5	4.58	3.5	12.60	5.3	25.46
1.6	4.87	3.6	13.22	5.4	25.80
1.7	5.17	3.7	13.88	5.5	26.00
1.8	5.47				



Flow diagrammes, DN 50

LENO™ MSV-BD DN 50

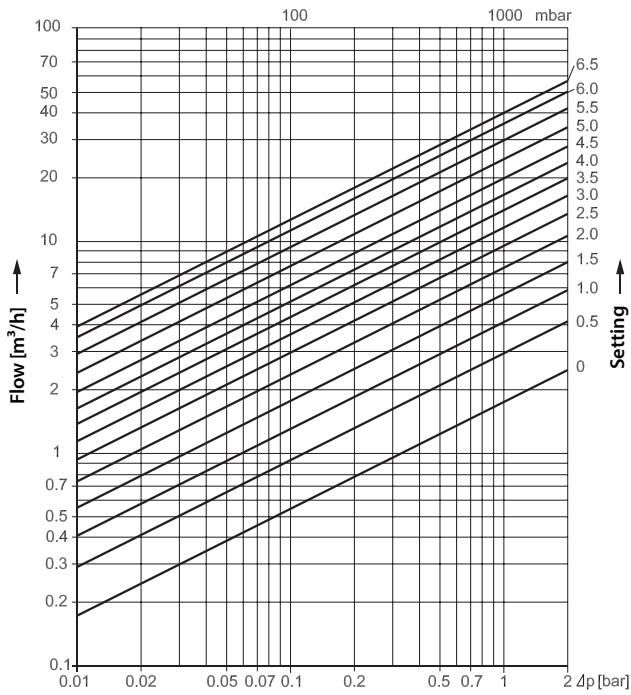

Flow characteristics

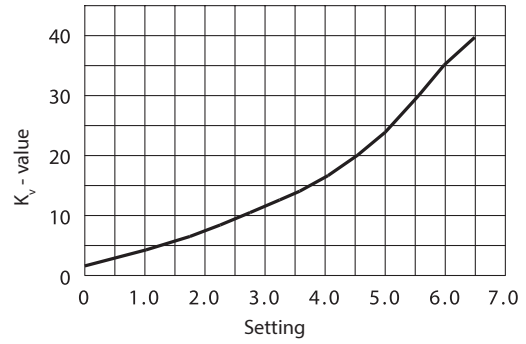

Settings

Setting and sealing

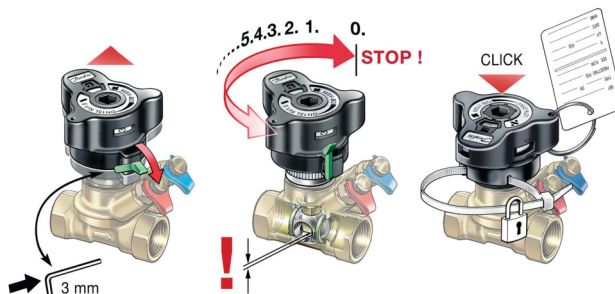

The valve has a presetting feature for setting/adjusting flow ratings.

Setting the required flow is made in 5 steps:

1. In open position, release the lock using the green lever or a 3 mm Allen key.
2. The handle pops up automatically.
3. The calculated value can now be set.
4. The setting is locked when the handle is pressed to click.
5. The setting can be sealed by using a strip as shown.

Sizing

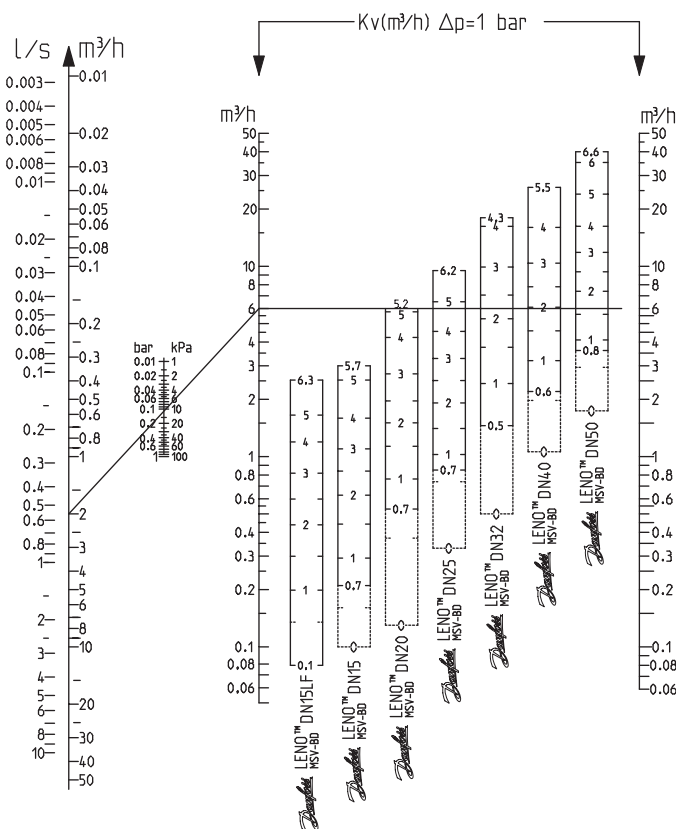

Presettings

Valve size and presetting

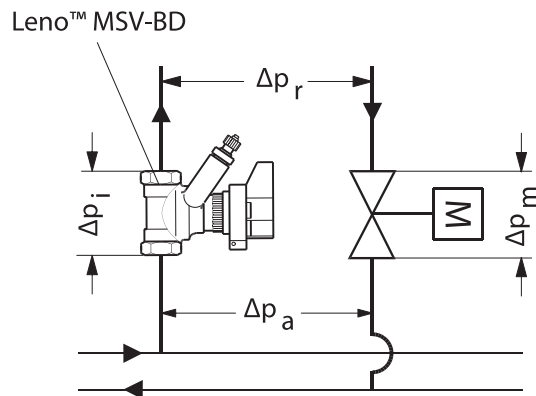

Δp_i Pressure drop across LENO™ MSV-BD valve
 Δp_m Pressure drop across valve

Δp_r Necessary pressure for the riser
 Δp_a Available pressure for the riser

Example

Given:

Max. pipe flow Q 2.0 m³/h

Δp_r 15 kPa

Δp_a 45 kPa

Δp_m 10 kPa

Δp_i $\Delta p_a - \Delta p_r - \Delta p_m$

$$\Delta p_i = 45 \text{ kPa} - 15 \text{ kPa} - 10 \text{ kPa} = 20 \text{ kPa}$$

Correct valve size and presetting is found in the sizing and flow diagrams.

$$Q = 2.0 \text{ m}^3/\text{h} \text{ and } \Delta p_i = 20 \text{ kPa}$$

Setting can be also calculated from the formula:

$$k_v = \frac{Q [\text{m}^3/\text{h}]}{\sqrt{\Delta p_i [\text{bar}]}} = \frac{2.0}{\sqrt{0.20}} = 4.5 \text{ m}^3/\text{h}$$

Product details

General data

Technical data

Max. static working pressure	20 bar
Static test pressure	30 bar
Max. differential pressure across valve	2.5 bar (250 kPa)
Max. flow temperature	120 °C
Min. temperature	-20 °C
Cooling liquids	Ethylene glycol / propylene glycol and HYCOOL (max. 30 %)

Design

1. Valve body
2. Ball seat
3. Ball
4. Throttle bush
5. Support screw
6. O-ring
7. Shut-off bush
8. O-ring
9. O-ring
10. O-ring
11. Retaining ring (corrosion protected)
12. Spring
13. Valve top
14. Spindle
15. O-ring
16. Rotation lock
17. Spindle head
18. Retaining ring, corrosion protected
19. Strips, 2 pcs.
20. Test plugs protection screw
21. Drain connection
22. Drain plug (PURE products only)

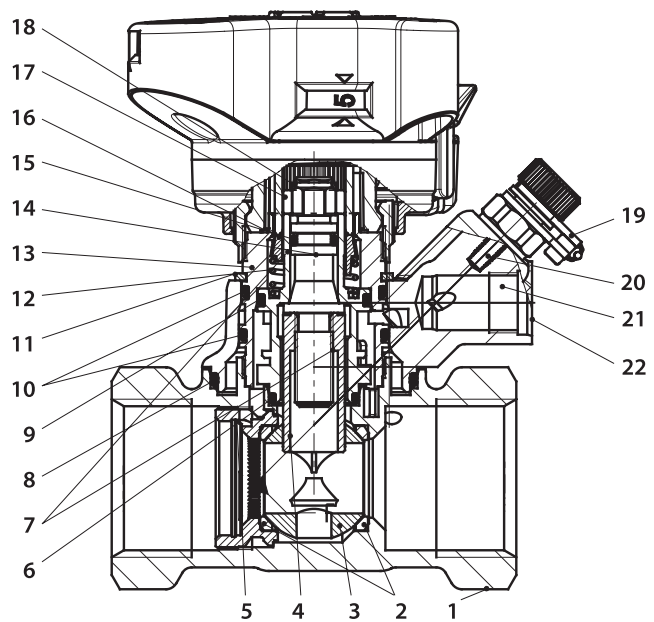

Materials

Valve body	DZR brass / Eco brass
O-rings	EPDM
Ball	Brass/chromium plated
Ball sealing	Teflon

Dimensions

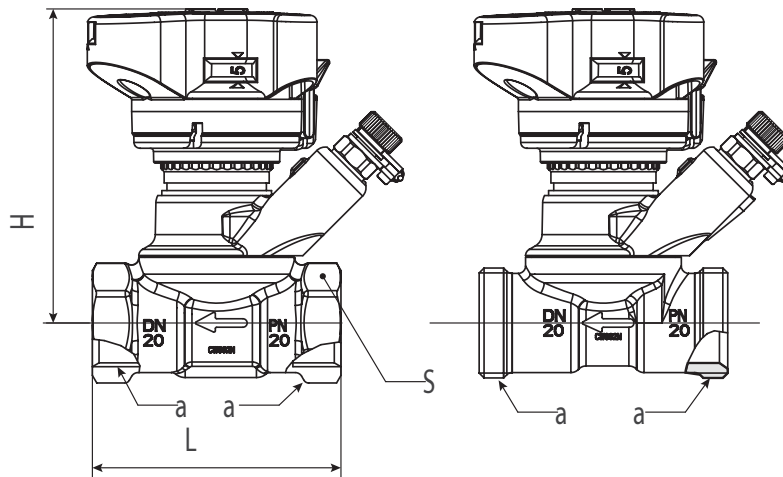

MSV-BD	Size	a Thread ISO 228-1	L (mm)	H (mm)	S (mm)
003Z4000	DN 15 LF	G ½	65	92	27
003Z4001	DN 15	G ½	65	92	27
003Z4002	DN 20	G ¾	75	95	32
003Z4003	DN 25	G 1	85	98	41
003Z4004	DN 32	G 1¼	96.5	121	50
003Z4005	DN 40	G 1½	100	125	55
003Z4006	DN 50	G 2	130	129	67
003Z4100	DN 15 LF	G ¾ A	70	92	-
003Z4101	DN 15	G ¾	70	92	-
003Z4102	DN 20	G 1 A	75	95	-

MSV-BD PURE	Size	a Thread ISO 228-1	L (mm)	H (mm)	S (mm)
003Z9990	DN 15 LF	G ½	65	92	27
003Z9991	DN 15	G ½	65	92	27
003Z9992	DN 20	G ¾	75	95	32
003Z9993	DN 25	G 1	85	98	41

Installation

Fitting

Before fitting the valve the installer must ensure that the pipe system is clean and:

1. the valve can be turned 360 degrees (if threaded pipe is used).
2. the valve is fitted according to the flow direction arrow.

Removal of the handle

1. Set the handle at 0.0.
2. Release the setting lock (green).
3. Unscrew the union nut.

Calibration of the handle

Before refitting, ensure that the handle setting is 0.0.

For DN 15 - 20 valves with external thread

Danfoss offers a complete range of compression fittings for steel, copper and PEX pipes.

DN	R1/R2 (mm)
15	86/67
20	89/69
25	91/71
32	118/84
40	118/84
50	124/90

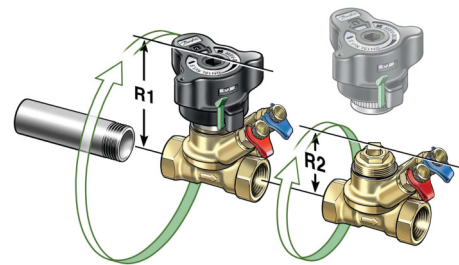

Certificates, declarations and approvals

The list contains all certificates, declarations, and approvals for this product type. Individual code number may have some or all of these approvals, and certain local approvals may not appear on the list.

When you click on the link you will be directed to the latest version of the 'Declaration of Conformity'. Products developed and sold before this date of issue conform to the directives/standards in force at the time of their sale.

Approval type	Title	Certification body	Approval topic
UA Declaration	Danfoss UA 2023-01-23 MTC ASV RA FH RAX PL03 PL28	Danfoss	PED, Pressure
Pressure Safety Certificate	LLC CDC EURO-TYSK UA.TR.089.1011.01-22	LLC CDC EURO TYSK - Ukraine	PED, Pressure
Export Control Declaration	Butterfly, other valves, Manual balancing valves, one pipe solution valves and hot water balancing valves	Danfoss	
Manufacturer's Declaration	Danfoss MD BF26012023-en01	Danfoss	EU RoHS, PED, Pressure

Tender text

Tender specifications

LENO™ MSV –BD can be used in heating and cooling systems.

Features	LENO™ MSV-BD
Balancing / Commissioning	•
Presetting	•
Fixed orifice	
Self sealing test plugs	•
Digital visible scale from more sides	•
Shut-off function (ball valve)	•
Draining / filling	•
Draining / filling on both sides of the valve	•
Removable handle	•
Closing indicator	•
Parallel test plugs (25mm center distance)	•
360° rotating measuring station (drain tap and test plugs)	•

Presetting values are visible on top of the valve and from all sides.

Presetting is locked by pressing down the handle. When locked, the shut-off function can be used without changing the presetting.

The handle is released with the green key or with a 3 mm Allen key.

To prevent unintended changes of the presetting, the handle can be sealed by using a strip.

The system can be drained and filled on both sides of the ball valve.

External thread versions comes in sizes DN 15 and DN 20 and are prepared for Danfoss standard fittings. DN 15 is designed with Euro cone, according to DIN V 3838.

LENO™ MSV-BD has a leakage rate A according to ISO 5208, the ball valve is 100% tight.

The LENO™ MSV-BD measuring accuracy is 8% at 25% of max. setting.

Accuracy is according to BS 7350 : 1990.

Measuring instruments must be equipped with Ø3 mm measuring needles. Danfoss measuring instruments PFM 1000 contain all relevant valve data.

Valve sizes DN 15 (LF) – DN 50 , DN 15 (LF) - DN25 (PURE)

Pressure class PN20

Static test pressure 30 bar

Working temperature -20°C to 120°C

Working area 10-100% of the k_{vs} -value

The valve body is made of DZR brass or Eco brass.

The ball is made of chromium plated brass.

O-rings are made from EPDM rubber.

MSV-BD and MSV-BD PURE are equal valves in all respects excluding the brass material. MSV-BD are made of DZR brass (CW602N) and MSV-BD PURE valves are made of Eco brass (CW724R). All remaining valve properties are unchanged.

Contact details

Online support

Danfoss offers a wide range of support along with our products, including digital information, software, mobile apps and expert guidance. See the possibilities below.



The Danfoss Design center

Discover the Design Center, our advanced digital platform that streamlines product selection. With integrated tools and enhanced type pages, it's simpler than ever to access product information and documentation, and to select the right products. Check the availability of Danfoss products at partner locations and enjoy seamless transitions from selection to purchase with our basket-to-basket functionality. Whether you're buying from our distributors or directly from the Product Store, the Design Center simplifies your experience. Learn more at: designcenter.danfoss.com.



The Danfoss product store

The Danfoss Product Store is a one-stop shop available 24/7 for our customers, no matter where you are in the world or what area of industry you work in. Browse our catalog, check product details and documentation, view your prices and product availability, and quickly finalize your purchase. Start browsing at: store.danfoss.com.



Danfoss Partner Portal/Product Data tool

Designed to support you with easy access to product data extracts, essential resources, tools, and information. The Partner Portal provides a centralized hub for product documentation, training materials, marketing assets, and technical support, ensuring you have everything you need to succeed and grow your business with Danfoss. The Partner Portal is available 24/7 at: partner.danfoss.com and is ready to support your business.



Find technical documentation

Find technical documentation you need to get your project up running. Get direct access to our official collection of data sheets, certificates and declarations, manuals and guides, 3D models and drawings, case stories, brochures, and much more. Start searching now at: documentation.danfoss.com.



Danfoss Learning

Danfoss Learning is a free online learning platform. It features courses and materials specifically designed to help engineers, installers, service technicians, and wholesalers better understand the products, applications industry topics, and trends that will help you do your job better. Find your local Danfoss website here: learning.danfoss.com.



Get local information and support

Local Danfoss websites are the main sources for help and information about our company and products. Find product availability, get the latest regional news, or connect with a nearby expert - all in your own language. Find your local Danfoss website here: danfoss.com.

Danfoss A/S

Climate Solutions . danfoss.com . +45 7488 2222

Any information, including, but not limited to information on selection of product, its application or use, product design, weight, dimensions, capacity or any other technical data in product manuals, catalogues description, advertisements, etc. and whether made available in writing, orally, electronically, online or via download, shall be considered informative, and is only binding if and to the extent, explicit reference is made in a quotation or order confirmation. Danfoss cannot accept any responsibility for possible errors in catalogues, brochures, videos and other material. Danfoss reserves the right to alter its products without notice. This also applies to products ordered but not delivered provided that such alterations can be made without changes to form, fit or function of the products. All trademarks in this material are property of Danfoss A/S or Danfoss group companies. Danfoss and the Danfoss logo are trademarks of Danfoss A/S. All rights reserved.
