



# Automatic balancing

## ASV-PV 4 gen

DN 15- 50

## Description

ASV valves are automatic balancing valves. Together with Danfoss presetting radiator thermostatic valves they are part of the **Danfoss two-pipe solution** and are perfect for creating optimal hydronic balance in residential two-pipe heating systems.

One of the major challenges in heating systems is a lack of good hydronic balancing, caused by differential pressure, which is changing constantly and unpredictably in the heating system. This results in complaints from residents about poor indoor comfort, noise and high energy bills.

Trying to solve these complaints, larger pumps are often installed to improve - especially under heated - circulation of the water. Unfortunately, this affects pressure differentials and energy consumption within the system even more. Besides, the higher pressure differential, the greater the noise from the system, particularly from radiator valves.

ASV automatic balancing valves ensure an optimal pressure differential for control valves as well as the correct flow within the individual risers at all times. This is the reason why DIN 18380 requires control of differential pressure at partial loads. The ASV automatically creates an optimal hydronic balance within the installation, whether under full or partial load. This balance is never disrupted.

The ASV valves can also be used in cooling applications (fan coil, chilled beam, etc) with variable flow, to secure an automatic hydronic balance (see general ASV datasheet for details).

## Features & benefits

- Fewer complaints
  - ASV makes the system more reliable, with less disturbances such as noisy radiators, under heating of rooms far away from the heat source, or over-heating of rooms close to the heat source. Fewer complaints means less call-backs to installer to solve the complaints.
- Improved indoor comfort
  - ASV provides stable pressure conditions to radiator or floor heating control valves resulting in more accurate room temperature control.
- Lower energy bills
  - Higher energy efficiency is contributed by solving overheating problem and ensuring more accurate temperature control. Proper balance prevents overflows thus resulting in low return water temperature, which improves energy efficiency of condensing boilers and district heating systems.
- Simplicity
  - ASV divides the piping system in pressure independent zones, typically individual risers or apartments so complex and time consuming calculation and commissioning methods are not needed anymore. It also allows a gradual connection of zones to the main constructions without additional balancing.
- Easy of use
  - The new generation of ASV automatic balancing valves is even simpler to use than before. The improved setting scale can now be set without using an allen key, saves time for the installer during commissioning and maintenance of the system while new flushing function saves time during flushing of pipe network.

## Applications

ASV balancing valves are designed to guarantee high quality of automatic balancing by:

- a pressure released cone
- an adapted membrane for valve dimension which provides constant quality performance for all sizes
- linear and accurate setting scale that makes setting required  $\Delta p$  easy
- low required 10 kPa pressure drop on ASV-PV valve contributes to smaller pump head

The Danfoss ASV solution comprises an automatic balancing valve ASV-PV and an associated partner valve (Fig. 1 and 2). The ASV-PV is a differential pressure controller, fitted into the return pipe. The partner valve is fitted into the supply pipe. Both valves are connected to each other using a impulse tube.

The pressure controller has a factory setting of 10 kPa or 30 kPa, perfect for typical radiator based heating systems. Of course it can easily be adjusted to another setting using the setting scale. If the pressure differential tends to become greater than this setting, then the ASV automatic balancing valve immediately reacts and keeps the pressure differential constant. By this the pressure in the controlled riser or loop does not increase due to any system load changes.

ASV balancing valves have integrated service functions such as:

- Flushing
- shut-off
- draining

Shut-off function is separated from the setting mechanism.

There are two basic configurations when using ASV partner valves:

### Partner valve outside the control loop (Fig.1).

Recommended valve ASV-BD (default configuration: blue test plug needs to be open, red is in closed position) or ASV-M: It results in best performance since whole controlled pressure range is available to the riser. Flow limitation is done on each terminal unit in the riser (for example, RA-N with presetting on radiator, etc).

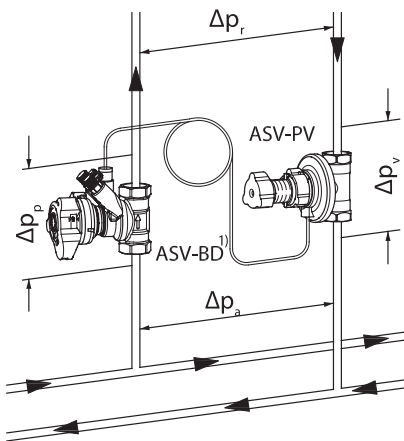

<sup>1)</sup> Please note that blue test plug on ASV-BD needs to be open (default configuration)

Fig. 1 Setting of ASV-PV =  $\Delta p_{riser}$  (partner valve outside the control loop)

### Partner valve inside the control loop (Fig.2).

Recommended valve ASV-BD (red test plug needs to be open, blue is in closed position): Offers flow limitation on the riser however part of the controlled pressure range is used by pressure drop on partner valve ( $\Delta p_p$ ). It is recommended when flow limitation on each terminal is not possible.

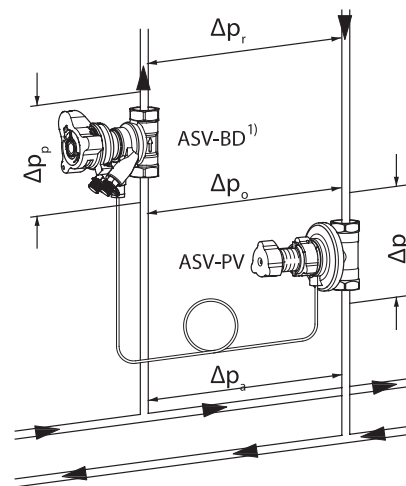

<sup>1)</sup> Please note that the red test plug on ASV-BD needs to be open and blue test plug closed

Fig. 2 Setting of ASV-PV =  $\Delta p_{riser} + \Delta p_p$

ASV-BD can be used outside or inside the control loop by choice of which measuring nipple is open. Change of configuration can be done under pressure - simply by closing/opening test plugs.

Configuration inside the control loop (default position) allows flow verification, while configuration outside the control loop allows flow limitation.

ASV valves are to be used in radiator heating systems to control the differential pressure in risers (Fig. 3) or horizontal loops - mostly used in new installation (Fig. 4). To limit the flow for every radiator, the thermostatic radiator valve with pre-setting function is used together with a constant pressure provided by the ASV, thus providing balanced heat distribution.

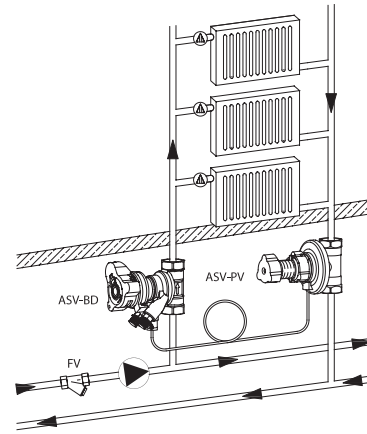

Fig. 3 ASV in vertical riser / typical radiator heating application (general example)

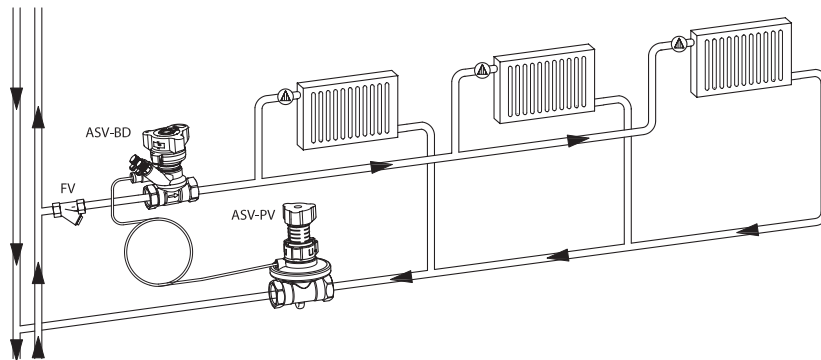

Fig. 4 ASV in horizontal loop / typical radiator heating application (general example)

ASV valves are also a perfect solution in floor heating systems (Fig. 5). To limit the flow, every manifold with integrated presetting should be used together with a constant pressure provided by an ASV-PV valve.

Alternatively the flow for the whole manifold can be limited by using the setting function of the ASV-BD. Due to its small dimensions the ASV automatic balancing valves are easy to install in a wall mounted box for floor heating manifolds.

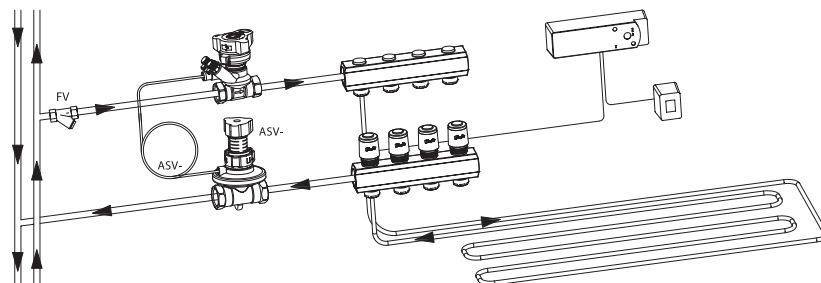

Fig. 5 ASV in manifold for floor heating system

## Ordering

### Product code numbers

ASV-PV balancing valve, included in the box: 1.5 m impulse tube (G  $\frac{1}{16}$  A)

Type	DN	$k_{vs}$ (m <sup>3</sup> /h)	Connection		$\Delta p$ setting range (kPa)	Code No.		Only for Danish market VVS-nr.
						without insulation	with EPP insulation	
	15	1.6	Internal thread ISO 7/1	R <sub>p</sub> 1/2	5-25	003Z5501	003Z5601	40 6853.604
	20	2.5		R <sub>p</sub> 3/4		003Z5502	003Z5602	40 6853.606
	25	4.0		R <sub>p</sub> 1		003Z5503	003Z5603	40 6853.608
	32	6.3		R <sub>p</sub> 1 1/4		003Z5504	003Z5604	40 6853.610
	40	10.0		R <sub>p</sub> 1 1/2		003Z5505	003Z5605	40 6853.612
	50	16.0		R <sub>p</sub> 2		003Z5506	003Z5606	40 6853.614
	15	1.6	External thread ISO 228/1	G 3/4 A	5-25	003Z5511	003Z5611	-
	20	2.5		G 1 A		003Z5512	003Z5612	
	25	4.0		G 1 1/4 A		003Z5513	003Z5613	
	32	6.3		G 1 1/2 A		003Z5514	003Z5614	
	40	10.0		G 1 3/4 A		003Z5515	003Z5615	
	50	16.0		G 2 1/4 A		003Z5516	003Z5616	
	15	1.6	Internal thread ISO 7/1	R <sub>p</sub> 1/2	20-60	003Z5541	-	40 6853.704
	20	2.5		R <sub>p</sub> 3/4		003Z5542		40 6853.706
	25	4.0		R <sub>p</sub> 1		003Z5543		40 6853.708
	32	6.3		R <sub>p</sub> 1 1/4		003Z5544		40 6853.710
	40	10.0		R <sub>p</sub> 1 1/2		003Z5545		40 6853.712
	50	16.0		R <sub>p</sub> 2		003Z5546		40 6853.714
	15	1.6	External thread ISO 228/1	G 3/4 A	20-60	003Z5551	-	-
	20	2.5		G 1 A		003Z5552		
	25	4.0		G 1 1/4 A		003Z5553		
	32	6.3		G 1 1/2 A		003Z5554		
	40	10.0		G 1 3/4 A		003Z5555		
	50	16.0		G 2 1/4 A		003Z5556		



ASV-PV PURE (Lead <0.1%) balancing valve, included in the box: 1.5 m impulse tube (G  $\frac{1}{16}$  A)

Type	DN	$k_{vs}$ (m <sup>3</sup> /h)	Connection		$\Delta p$ setting range (kPa)	Code No.	
						without insulation	with EPP insulation
	15	1.6	Internal thread ISO 7/1	R <sub>p</sub> 1/2	5-25	-	003Z5621
	20	2.5		R <sub>p</sub> 3/4			003Z5622
	25	4.0		R <sub>p</sub> 1			003Z5623

**ASV-BD shut-off valve, multifunctional partner valve (shut-off, rotating measuring station) DZR brass and EPP insulation**

Type	DN	$k_{vs}$ (m <sup>3</sup> /h)	Connection		Code No.
	15	3.0	Internal thread ISO 228/1	G ½	<b>003Z4041</b>
	20	6.0		G ¾	<b>003Z4042</b>
	25	9.5		G 1	<b>003Z4043</b>
	32	18		G 1¼	<b>003Z4044</b>
	40	26		G 1½	<b>003Z4045</b>
	50	40		G 2	<b>003Z4046</b>

**ASV-M shut-off valve, without test plugs and with EPS insulation**

Type	DN	$k_{vs}$ (m <sup>3</sup> /h)	Connection		Code No.
	15	1.6	Internal thread ISO 7/1	R <sub>p</sub> ½	<b>003L7691</b>
	20	2.5		R <sub>p</sub> ¾	<b>003L7692</b>
	25	4.0		R <sub>p</sub> 1	<b>003L7693</b>
	32	6.3		R <sub>p</sub> 1¼	<b>003L7694</b>
	40	10		R <sub>p</sub> 1½	<b>003L7695</b>
	15	1.6	External thread ISO 228/1	G ¾ A	<b>003L7696</b>
	20	2.5		G 1 A	<b>003L7697</b>
	25	4.0		G 1¼ A	<b>003L7698</b>
	32	6.3		G 1¾ A	<b>003L7699</b>
	40	10		G 2 A	<b>003L7700</b>
	50	16		G 2¼ A	<b>003L7702</b>

**ASV-BD PURE (Lead <0.1%) shut-off valve, multifunctional partner valve (shut-off, rotating measuring station) ecobrass and EPP insulation**

Type	DN	$k_{vs}$ (m <sup>3</sup> /h)	Connection		Code No.
	15	3.0	Internal thread ISO 228/1	G ½	<b>003Z4941</b>
	20	6.0		G ¾	<b>003Z4942</b>
	25	9.5		G 1	<b>003Z4943</b>

**ASV-D shut-off valve, multi-functional partner valve**

Type	DN	$k_{vs}$ (m <sup>3</sup> /h)	Connection		Code No.
	15	3.0	Internal thread ISO 228/1	G ½	<b>003Z7008</b>
	20	6.0		G ¾	<b>003Z7009</b>
	25	9.5		G 1	<b>003Z7010</b>
	32	18		G 1¼	<b>003Z7011</b>
	40	26		G 1½	<b>003Z7012</b>
	50	40		G 2	<b>003Z7013</b>

**ASV-M shut-off valve, with test plugs and with EPS insulation**

Type	DN	$k_{vs}$ (m <sup>3</sup> /h)	Connection	Code No.	
	15	1.6	Internal thread ISO 228/1	R <sub>p</sub> 1/2	<b>003L7681</b>
	20	2.5		R <sub>p</sub> 3/4	<b>003L7682</b>
	25	9.5		R <sub>p</sub> 1	<b>003L7683</b>
	32	18		R <sub>p</sub> 1 1/4	<b>003L7684</b>
	40	26		R <sub>p</sub> 1 1/2	<b>003L7685</b>

**Accessories code numbers**

<p>003Z7860</p> <p><b>Label tag, ASV-PV 4g DN 15 - 50</b></p> <p>Label tag, ASV-PV 4g DN 15 - 50</p>	<p>003Z0229</p> <p><b>Tailpiece for welding DN 32 (1 pc.)</b></p> <p>Tailpiece for welding DN 32 (1 pc.)</p>	<p>003Z0235</p> <p><b>Tailpiece with External thread DN 32</b></p> <p>Tailpiece with External thread DN 32</p>	<p>003Z7850</p> <p><b>ASV-PV 4g flushing accessory</b></p> <p>ASV-PV 4g flushing accessory</p>	<p>003Z0689</p> <p><b>Plastic impulse tube with connectors and adapters, 1,5 m, Industry pack</b></p> <p>Plastic impulse tube with connectors and adapters, 1,5 m, Industry pack</p>
<p>003L8151</p> <p><b>Plug for connecting impulse tube, G1/16-R1/4</b></p> <p>Plug for connecting impulse tube, G1/16-R1/4</p>	<p>003Z7802</p> <p><b>EPP Insulation cap for ASV-PV DN 25, Tmax 120 C</b></p> <p>EPP Insulation cap for ASV-PV DN 25, Tmax 120 C</p>	<p>003Z0233</p> <p><b>Tailpiece with External thread DN 20</b></p> <p>Tailpiece with External thread DN 20</p>	<p>003Z0227</p> <p><b>Tailpiece for welding DN 20 (1 pc.)</b></p> <p>Tailpiece for welding DN 20 (1 pc.)</p>	<p>003Z0273</p> <p><b>Tailpiece with thread DN 40 (1 3/4" nut)</b></p> <p>Tailpiece with thread DN 40 (1 3/4" nut)</p>



003L8175

**O-ring for impulse tube (10 pcs.)**

O-ring for impulse tube (10 pcs.)



003Z7804

**EPP Insulation cap for ASV-PV DN 40 - 50, Tmax 120 C**

EPP Insulation cap for ASV-PV DN 40 - 50, Tmax 120 C



003L8152

**Impulse tube with O-rings, 1,5 m**

Impulse tube with O-rings, 1,5 m



003L8153

**Impulse tube with O-rings, 5 m**

Impulse tube with O-rings, 5 m

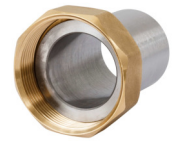

003Z0272

**Tailpiece for welding DN 50 (2 1/4" nut)**

Tailpiece for welding DN 50 (2 1/4" nut)



003Z7838

**Upgrade kit ASV-PV DN 50, 20-80 kPa**

Upgrade kit ASV-PV DN 50, 20-80 kPa



003Z7835

**Upgrade kit ASV-PV 4g DN 50, 20-60 kPa**

Upgrade kit ASV-PV 4g DN 50, 20-60 kPa



003Z0274

**Tailpiece with thread DN 50 (2 1/4" nut)**

Tailpiece with thread DN 50 (2 1/4" nut)



003Z7845

**Setting scale service kit ASV-PV 4g DN 50, 5-25 kPa**

Setting scale service kit ASV-PV 4g DN 50, 5-25 kPa



003Z0278

**Tailpiece with External thread DN 50**

Tailpiece with External thread DN 50



003Z0691

**1/4" combined impulse tube adapter for large ASV**

1/4" combined impulse tube adapter for large ASV

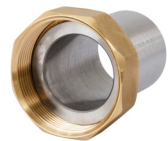

003Z0276

**Tailpiece for welding DN 50 (1 pc.)**

Tailpiece for welding DN 50 (1 pc.)



003L8143

**Measuring connector for drain connection 3/4"**

Measuring connector for drain connection 3/4"



003Z0690

**Impulse tube with O-rings, 2,5 m**

Impulse tube with O-rings, 2,5 m



003Z7800

**EPP Insulation cap for ASV-PV DN 15-20, Tmax 120 C**

EPP Insulation cap for ASV-PV DN 15-20, Tmax 120 C

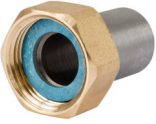

003Z0226

**Tailpiece for welding DN 15 (1 pc.)**

Tailpiece for welding DN 15 (1 pc.)



003Z7841

**Setting scale service kit ASV-PV 4g DN 15 - 20, 5-25 kPa**

Setting scale service kit ASV-PV 4g DN 15 - 20, 5-25 kPa



003Z0232

**Tailpiece with External thread DN 15**

Tailpiece with External thread DN 15



003Z7831

**Upgrade kit ASV-PV 4g DN 15 - 20, 20-60 kPa**

Upgrade kit ASV-PV 4g DN 15 - 20, 20-60 kPa



003Z0234

**Tailpiece with External thread DN 25**

Tailpiece with External thread DN 25

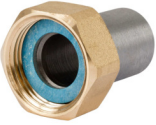

003Z0228

**Tailpiece for welding DN 25 (1 pc.)**

Tailpiece for welding DN 25 (1 pc.)



003Z0271

**Tailpiece for welding DN 40 (1 3/4" nut)**

Tailpiece for welding DN 40 (1 3/4" nut)



003Z7803

**EPP Insulation cap for ASV-PV DN 32, Tmax 120 C**

EPP Insulation cap for ASV-PV DN 32, Tmax 120 C

**Spare parts code numbers**



003Z7857

**ASV-PV 4g handle DN 32 - 50**

ASV-PV 4g handle DN 32 - 50



003Z7843

**Setting scale service kit ASV-PV 4g DN 32, 5-25 kPa**

Setting scale service kit ASV-PV 4g DN 32, 5-25 kPa



003L8141

**Drain connection G 3/4 A**

Drain connection G 3/4 A



003Z0690

**Impulse tube with O-rings, 2,5 m**

Impulse tube with O-rings, 2,5 m



003L8143

**Measuring connector for drain connection 3/4"**

Measuring connector for drain connection 3/4"



003L8152

**Impulse tube with O-rings, 1,5 m**

Impulse tube with O-rings, 1,5 m



003L8153

**Impulse tube with O-rings, 5 m**

Impulse tube with O-rings, 5 m



003L8175

**O-ring for impulse tube (10 pcs.)**

O-ring for impulse tube (10 pcs.)



003Z0234

**Tailpiece with External thread DN 25**

Tailpiece with External thread DN 25



003Z7842

**Setting scale service kit ASV-PV 4g DN 25, 5-25 kPa**

Setting scale service kit ASV-PV 4g DN 25, 5-25 kPa

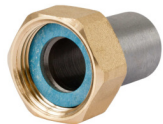

003Z0228

**Tailpiece for welding DN 25 (1 pc.)**

Tailpiece for welding DN 25 (1 pc.)



003Z7855

**ASV-PV 4g handle DN 15 - 25**

ASV-PV 4g handle DN 15 - 25



003Z7831

**Upgrade kit ASV-PV 4g DN 15 - 20, 20-60 kPa**

Upgrade kit ASV-PV 4g DN 15 - 20, 20-60 kPa



003Z7834

**Upgrade kit ASV-PV 4g DN 40, 20-60 kPa**

Upgrade kit ASV-PV 4g DN 40, 20-60 kPa



003Z7832

**Upgrade kit ASV-PV 4g DN 25, 20-60 kPa**

Upgrade kit ASV-PV 4g DN 25, 20-60 kPa



003Z7844

**Setting scale service kit ASV-PV 4g DN 40, 5-25 kPa**

Setting scale service kit ASV-PV 4g DN 40, 5-25 kPa



003Z7841

**Setting scale service kit ASV-PV 4g DN 15 - 20, 5-25 kPa**

Setting scale service kit ASV-PV 4g DN 15 - 20, 5-25 kPa



003Z7833

**Upgrade kit ASV-PV 4g DN 32, 20-60 kPa**

Upgrade kit ASV-PV 4g DN 32, 20-60 kPa

## Functions

### Operation

#### Flushing

ASV-PV valves provides ability to flush the system from flow pipe. Use the following procedure for flushing the system:

1. Ensure system is filled with water
2. Dismount shut off handle ① and fit flushing accessory ② (Code No. **003Z7850**) on the ASV-PV valve spring guide.
3. Rotate by hand flushing accessory clockwise to end position before flushing the system ③.
4. Flushing of the system should be done with flow in direction of the arrow on the valve body.
5. After flushing the system rotate counter clockwise to starting position.

**Note:** Make sure system is filled with water before mounting flushing accessory to ensure differential pressure does not exceed 5 bar.

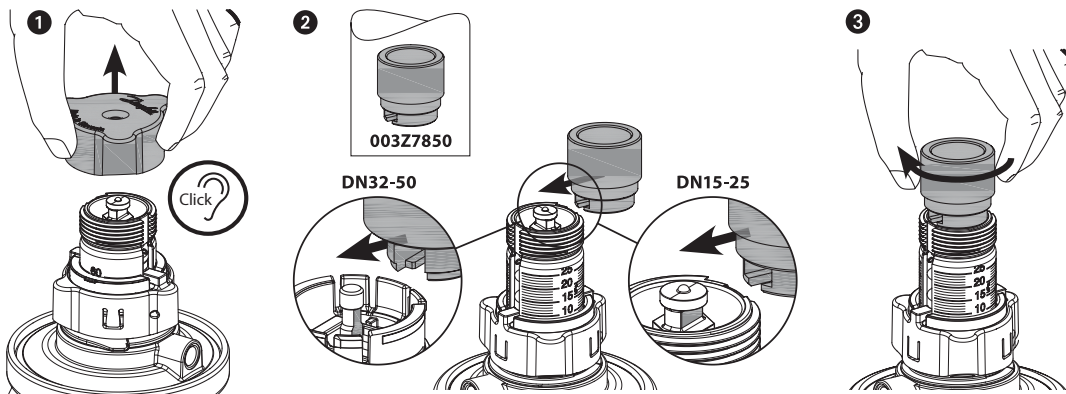

## Settings

### $\Delta p$ setting

The setting of differential pressure can be easily changed using the setting scale, which saves time for the installer during maintenance of the system.

Use the following procedure to set the desired differential pressure:

1. Unblock the setting ①.
2. Make the setting by rotating of scale to desire value ②.
3. Block the setting back to final position ③.

### Factory presetting

$\Delta p$ setting range (kPa)	kPa
5 - 25	10
20 - 60	30

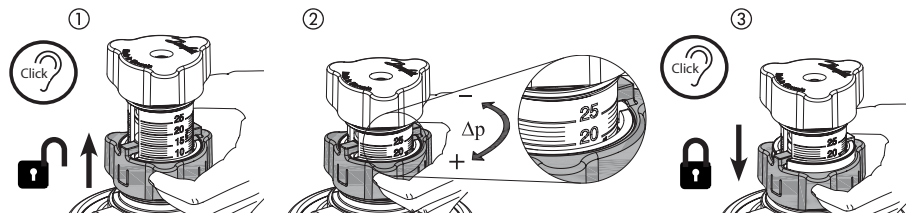

## Product details

### General data

#### Technical data

Type		ASV-PV	ASV-M	ASV-BD	ASV-D <sup>3)</sup>	ASV-PV PURE	ASV-BD PURE
Nominal diameter	DN	15-50	15-50	15-50	15-50	15-25	15-25
Max. pressure (PN)	bar	16	16	20	20	16	20
Test pressure		25	25	30	30	25	30
Differential pressure over the valve <sup>1)</sup>	kPa	10-250	10-150	10-250	10-250	10-250	10-250
Shut Off leakage		No visible leakage <sup>2)</sup>	D <sup>2)</sup>	A <sup>2)</sup>	A <sup>2)</sup>	No visible leakage <sup>2)</sup>	A <sup>2)</sup>
Working temperature	°C	0 ... 120	-20 ... 120	-20 ... 120	-20 ... 120	0 ... 120	-20 ... 120
Storage and transport temperature		-40 ... 70					

<sup>1)</sup> Please note that the maximum admissible differential pressure across the valve should also not be exceeded at partial load.

<sup>2)</sup> ISO 5208

<sup>3)</sup> For more information see ASV-D datasheet

**Sizing**

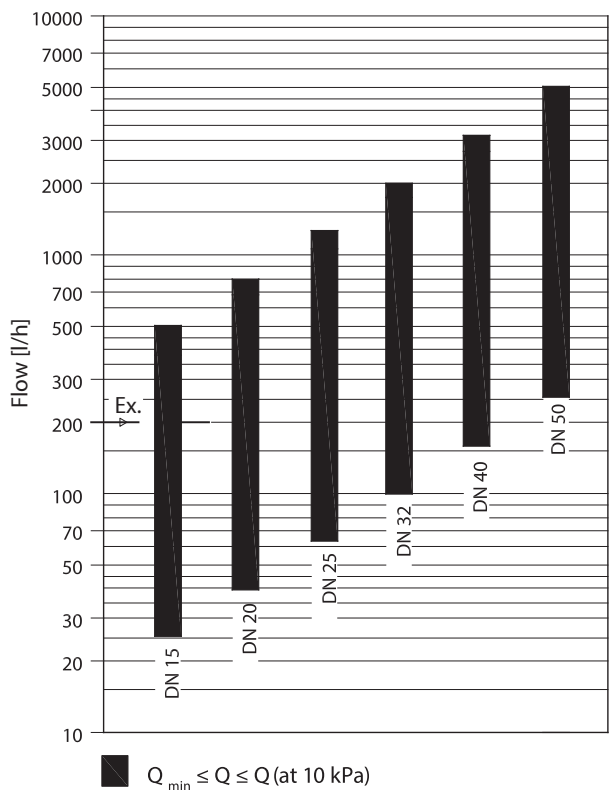

Fig. 9 Column diagram for sizing  $Q$ =required design flow ASV valves at  $\Delta p_v = 10$  kPa. For different  $\Delta p_v$  values use diagram A and B in Appendix.

We recommend to size the diameter of ASV-PV valves by using Fig 9. Maximum flow rates are based on 10 kPa differential pressure over ASV-PV valve which allows perfect control performance of ASV-PV and saves energy, while minimal nominal flow allow controllability close to zero.

After ASV-PV valves have been sized the same dimension of partner valve ASV-BD / ASV-M valve should be selected.

**Example:**

Given:

Pipe flow 200 l/h, pipes DN 15

Solution:

Horizontal line intersects the column for the valve DN 15 which can therefore be selected as required size (in case more columns are intersected the smaller valve size is recommended.)

For detailed sizing see examples under the chapter Dimensions.

For different  $\Delta p_v$  (differential pressure over the valve) see diagrams in **Appendix A**.

**Connection between valves size and pipe size**

$K_v$  values per particular dimension were designed to cover flow range according to VDI 2073 with water velocity of up 0.8 m/s, at differential pressure of 10 kPa over the valve. As long as the water velocity in the pipe is between 0.3 and 0.8 m/s dimension of the valve should be equal to pipe dimension.

This rule is derived out of the fact that  $K_v$  values per particular dimension were designed to cover flow range according to VDI 2073 at differential pressure of 10 kPa over the ASV-PV valve.

## Sizing-design examples

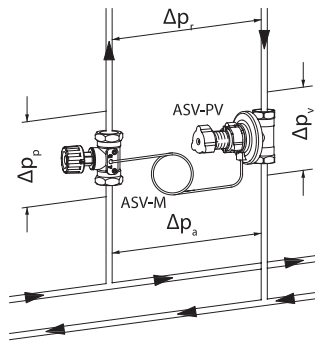

Fig. 10

### 1. Example

#### Given:

Radiator system with thermostatic radiator valves with pre-setting function.

Desired flow for the riser ( $Q$ ): 900 l/h

Minimal available pressure for that riser ( $\Delta p_a$ ): 60 kPa

Estimated pressure drop over the riser at the desired flow ( $\Delta p_r$ ): 10 kPa

#### Wanted:

- Valve type
- Valve size

Since radiator valves have pre-setting function ASV-M is selected.

ASV-PV should control 10 kPa pressure over the riser that means that 50 kPa out of 60 will be disposed over two valves.

$$\Delta p_v + \Delta p_p = \Delta p_a - \Delta p_r = 60 - 10 = 50 \text{ kPa}$$

We presume that dimension DN 25 is the right dimension for this example (please mind that both valves should be of the same dimension). As ASV-M DN 25 is to be fully open pressure drop is calculated by following equation:

$$\Delta p_p = \left(\frac{Q}{K_v}\right)^2 = \left(\frac{0.9}{4.0}\right)^2 = 0.05 \text{ bar} = 5 \text{ kPa}$$

or by reading from diagram in **Appendix A**, fig. C as follows:

Draw horizontal line from 0.9 m<sup>3</sup>/h (~900 l/h) through the line that depicts dimension DN 25. From the intersection draw vertical line to read that pressure drop is 5 kPa.

Pressure drop over ASV-PV valve is therefore:

$$\Delta p_v = (\Delta p_a - \Delta p_r) - \Delta p_p = 50 \text{ kPa} - 5 \text{ kPa} = 45 \text{ kPa}$$

as can be read from diagram in **Appendix A**, Fig. A.

$$\Delta p_a \geq \Delta p_p + \Delta p_r + \Delta p_v$$

$\Delta p_v$	Pressure drop across ASV-PV
$\Delta p_p$	Pressure drop across ASV-M valve
$\Delta p_r$	Necessary pressure for the riser
$\Delta p_a$	Available pressure for the riser

### 2. Example

Correcting the flow with the differential pressure setting.

#### Given:

Measured flow for the riser  $Q_1$ : 900 l/h

ASV-PV valve's setting  $\Delta p_r$ : 10 kPa

#### Wanted:

New valves' setting to increase the flow for 10 %,  $Q_2 = 990$  l/h.

#### Setting on the ASV-PV valve:

When needed setting of the control pressure can be adjusted to particular value or 20-60 kPa.

With increasing/decreasing the setting it is possible to adjust flow through the riser, terminal or similar. (100 % increase of control pressure will increase the flow for approx. 41 %):

$$p_2 = p_1 \times \left(\frac{Q_2}{Q_1}\right)^2 = 0.10 \times \left(\frac{990}{900}\right)^2 = 12 \text{ kPa}$$

If we increase the setting to 12 kPa flow will be increased to 10 % to 990 l/h

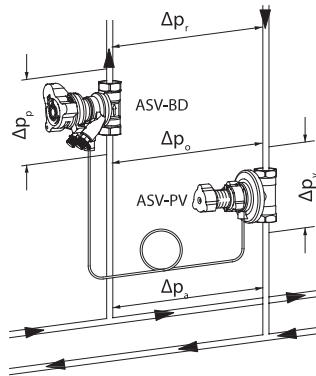

$$\Delta p_a \geq \Delta p_p + \Delta p_r + \Delta p_v$$

- $\Delta p_v$  Pressure drop across ASV-PV valve
- $\Delta p_p$  Pressure drop across ASV-BD valve
- $\Delta p_o$  Pressure drop in the riser including ASV-BD
- $\Delta p_a$  Available pressure for the riser
- $\Delta p_r$  Pressure drop in the riser excluding ASV-BD

Fig. 11

### 3. Example

Limiting the flow with ASV-BD valve

Given:

Desired flow for the branch (Q): 880 l/h

ASV-PV and ASV-BD (DN 25)

Setting on the ASV-PV valve ( $\Delta p_o$ ): 10 kPa

Estimated pressure drop over the riser at desired flow ( $\Delta p_r$ ): 7 kPa

Required:

Setting of the ASV-BD valve to achieve desired flow

Solution:

When needed setting of the ASV-BD can be adjusted to perform flow limitation function. ASV-BD namely is inside the control loop of the pressure controller therefore adjusting ASV-BD would result in adjusting flow limitation. Red test plug on ASV-BD valve needs to be open (blue one in closed position). (General rule is that 100 % increase of  $k_v$  value will increase the flow for 100 %).

$$k_v = \frac{Q}{\sqrt{\Delta p_o}} = \frac{0.880}{\sqrt{0.03}} = 5.1 \text{ m}^3/\text{h}$$

The result can be read as well from diagram in Appendix A, Fig.B.

At desired flow pressure drop over the entire branch is 7 kPa.

Without using ASV-BD flow through the branch at fully open control valve will be 19% higher thus causing overflow (7 kPa allow 880 l/h, while 10 kPa allow 1.050 l/h). With adjusting the ASV-BD DN 25 pre-setting to 4.3  $k_v$  value (5.1 m<sup>3</sup>/h) we will limit the flow to 880 l/h as desired.

This value is obtained by following calculation:

$$\Delta p_p = \Delta p_o - \Delta p_r = 10 - 7 = 3 \text{ kPa.}$$

Alternative, flow limitation can also be done by bigger  $\Delta p$  setting on ASV-PV valve.

### 4. Example

Floor heating application with ASV-PV on return manifold

Given:

Pressure drop (largest loop): 16 kPa

Pressure drop manifold: 2 kPa

Flow demand of manifold: 900 l/h

Connection pipe: DN25

Wanted:

- Valve size (DN)
- Valve setting ( $\Delta p_o$ )

ASV-PV DN25 / 5-25 kPa is selected (same size as connection pipe).

Since the valve setting is given by sum of total pressure loss:

$$\Delta p_o = \Delta p_{loop} + \Delta p_{manifold} = 16 \text{ kPa} + 2 \text{ kPa} = 18 \text{ kPa}$$

Setting 18 kPa on ASV-PV setting scale is needed.

Appendix A-Sizing diagram

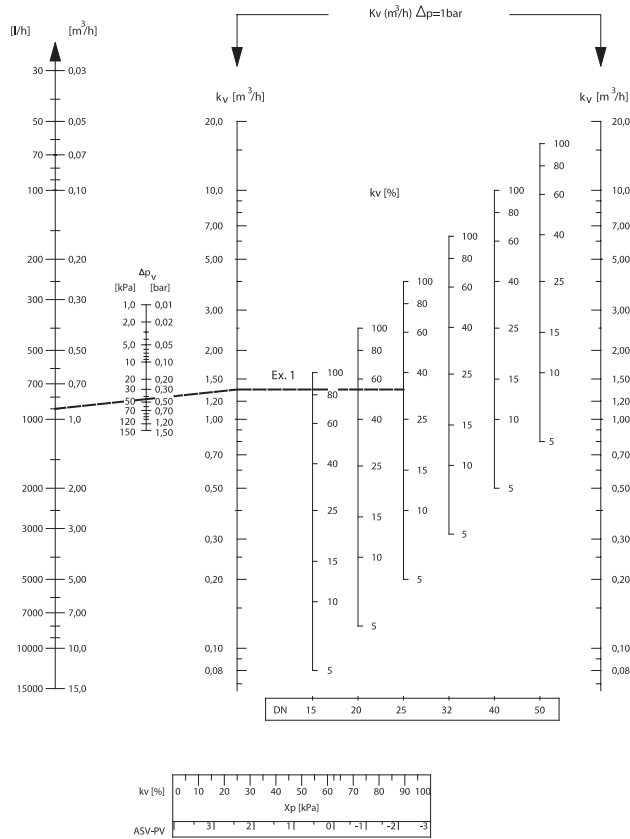

Fig. A - Sizing diagram ASV-PV DN 15-50

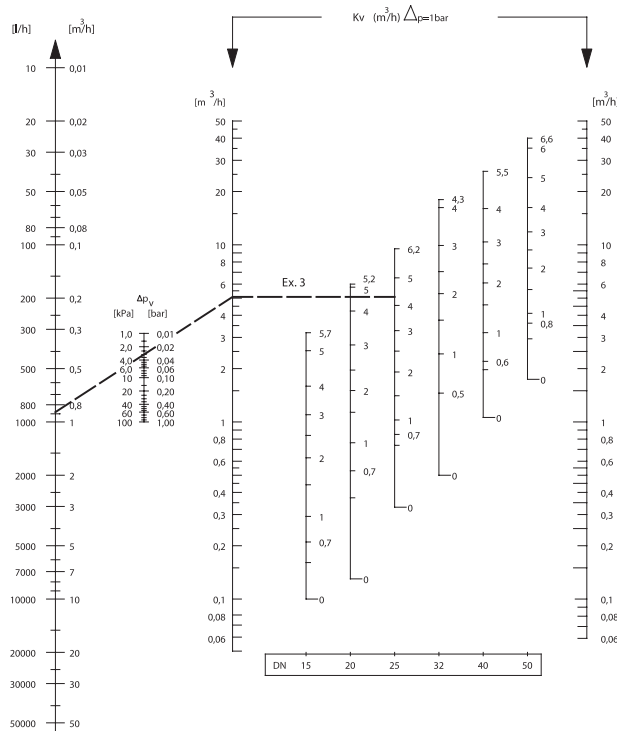

Fig.B - Sizing diagram ASV-BD DN 15-50

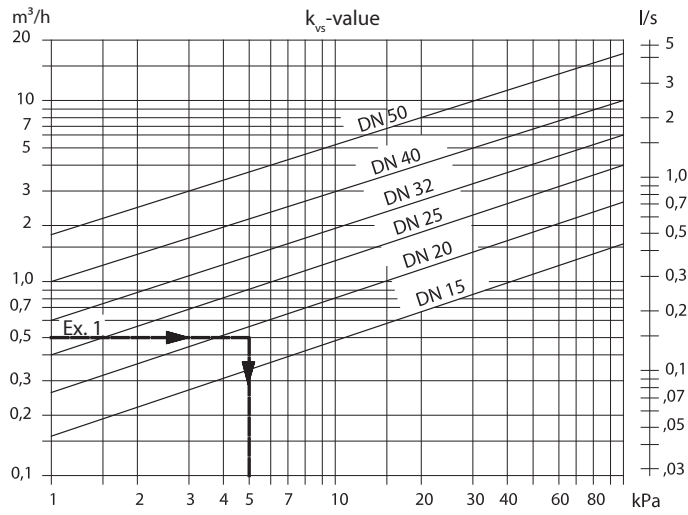

Fig.C - Pressure drop over ASV-M valves, DN 15-50

**Appendix B**ASV-BD  $K_v$  signal values

Setting	DN 15LF	DN 15	DN 20	DN 25	DN 32	DN 40	DN 50
0.0	0.07	0.10	0.12	0.34	0.51	1.05	1.75
0.1	0.08	0.11	0.16	0.44	0.73	1.20	2.01
0.2	0.09	0.12	0.20	0.53	0.92	1.36	2.25
0.3	0.11	0.13	0.26	0.61	1.10	1.55	2.47
0.4	0.12	0.14	0.32	0.67	1.26	1.74	2.69
0.5	0.13	0.16	0.38	0.73	1.43	1.95	2.91
0.6	0.15	0.19	0.45	0.79	1.60	2.17	3.12
0.7	0.16	0.21	0.53	0.84	1.78	2.40	3.35
0.8	0.17	0.24	0.60	0.90	1.97	2.64	3.58
0.9	0.19	0.26	0.67	0.95	2.18	2.88	3.82
1.0	0.20	0.29	0.74	1.01	2.39	3.13	4.07
1.1	0.21	0.32	0.82	1.08	2.62	3.39	4.33
1.2	0.23	0.34	0.89	1.14	2.87	3.64	4.60
1.3	0.25	0.37	0.96	1.22	3.12	3.90	4.89
1.4	0.27	0.40	1.03	1.29	3.38	4.16	5.18
1.5	0.30	0.44	1.09	1.37	3.64	4.43	5.49
1.6	0.32	0.47	1.16	1.46	3.92	4.69	5.80
1.7	0.35	0.51	1.23	1.55	4.19	4.96	6.13
1.8	0.37	0.54	1.30	1.65	4.48	5.24	6.46
1.9	0.40	0.58	1.38	1.75	4.76	5.51	6.80
2.0	0.43	0.61	1.45	1.85	5.05	5.80	7.14
2.1	0.46	0.65	1.53	1.96	5.35	6.08	7.49
2.2	0.49	0.69	1.61	2.07	5.65	6.38	7.84
2.3	0.52	0.73	1.69	2.18	5.96	6.68	8.19
2.4	0.56	0.77	1.78	2.29	6.27	6.99	8.55
2.5	0.59	0.80	1.87	2.41	6.60	7.30	8.91
2.6	0.62	0.85	1.97	2.53	6.94	7.63	9.27
2.7	0.66	0.89	2.07	2.65	7.29	7.98	9.64
2.8	0.69	0.93	2.17	2.77	7.67	8.33	10.00
2.9	0.73	0.97	2.29	2.89	8.06	8.70	10.37
3.0	0.76	1.01	2.40	3.01	8.48	9.08	10.74



Setting	DN 15LF	DN 15	DN 20	DN 25	DN 32	DN 40	DN 50
3.1	0.80	1.04	2.52	3.13	8.92	9.48	11.11
3.2	0.83	1.08	2.65	3.25	9.38	9.90	11.49
3.3	0.87	1.12	2.78	3.37	9.87	10.33	11.88
3.4	0.90	1.16	2.91	3.49	10.38	10.79	12.27
3.5	0.94	1.20	3.05	3.62	10.91	11.26	12.67
3.6	0.97	1.25	3.19	3.74	11.46	11.74	13.09
3.7	1.01	1.30	3.33	3.87	12.02	12.25	13.51
3.8	1.06	1.35	3.47	4.00	12.58	12.77	13.95
3.9	1.10	1.41	3.61	4.13	13.12	13.30	14.41
4.0	1.14	1.47	3.75	4.26	13.64	13.85	14.88
4.1	1.18	1.53	3.89	4.39	14.12	14.41	15.38
4.2	1.23	1.59	4.02	4.53	14.52	14.98	15.89
4.3	1.27	1.66	4.15	4.68	14.84	15.55	16.44
4.4	1.31	1.73	4.28	4.82	-	16.13	17.00
4.5	1.35	1.81	4.40	4.98	-	16.69	17.59
4.6	1.39	1.91	4.52	5.13	-	17.25	18.21
4.7	1.43	2.00	4.62	5.29	-	17.80	18.86
4.8	1.47	2.08	4.72	5.46	-	18.32	19.54
4.9	1.51	2.16	4.82	5.64	-	18.80	20.24
5.0	1.54	2.23	4.90	5.81	-	19.25	20.97
5.1	1.60	2.30	4.97	6.00	-	19.65	21.73
5.2	1.66	2.36	5.04	6.19	-	19.98	22.51
5.3	1.72	2.41	-	6.38	-	20.24	23.30
5.4	1.79	2.46	-	6.57	-	20.41	24.12
5.5	1.87	2.50	-	6.77	-	20.48	24.94
5.6	1.93	2.54	-	6.96	-	-	25.76
5.7	1.99	2.57	-	7.15	-	-	26.58
5.8	2.04	-	-	7.34	-	-	27.38
5.9	2.09	-	-	7.52	-	-	28.16
6.0	2.14	-	-	7.69	-	-	28.90
6.1	2.18	-	-	7.85	-	-	29.59
6.2	2.22	-	-	7.98	-	-	30.21
6.3	2.26	-	-	-	-	-	30.74
6.4	-	-	-	-	-	-	31.17
6.5	-	-	-	-	-	-	31.47
6.6	-	-	-	-	-	-	31.61

## Insulation

ASV-PV (versions with insulation) and ASV-BD valve are supplied together with EPP insulation cap. Insulation cap offers click on feature for fast and easy mounting on the valve. Insulation cap in EPP is offered for use at higher temperatures, up to 120 °C.

ASV-M valve is supplied with EPS insulation packaging, which can be used as insulation in systems where the temperature does not exceed 80 °C under continuous operation.

For ordering see **Accessories and spare parts table**.

Both materials (EPS and EPP) are approved in accordance with fire class standard B2, DIN 4102

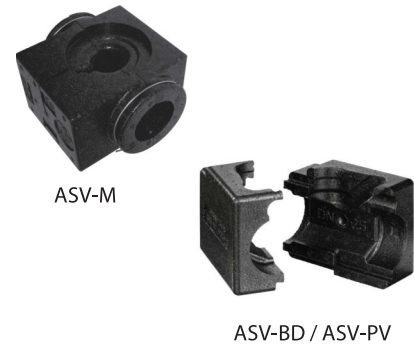

## Design

1. Spring guide
2. Shut-off handle
3. Spring
4. Differential pressure setting spindle
5. Setting scale
6. O-ring
7. Locking ring
8. Impulse tube connection
9. Diaphragm element
10. Control diaphragm
11. Internal connection
12. Valve body
13. Pressure-relieved valve cone
14. Seat

ASV-PV is a compact differential pressure controller designed to guarantee high quality of automatic balancing. Innovative construction and ease of use are incorporated into the valve with the following features:

- integrated membrane part into valve body ⑫,
- easy setting with locking function ⑦,
- flushing function,
- shut-off function, separated from presetting
- membrane adapted to valve size.

Via an internal connection and together with the reference spring ③, pressure in the return pipe acts on the lower side of the control diaphragm ⑩ while via an impulse tube ⑧, pressure in the flow pipe acts on the top of the diaphragm. In this way the balancing valve maintains adjusted differential pressure.

The valves factory set to 10 kPa or 30 kPa. They can be easily adjusted to another setting using setting scale ⑤. Turning the setting ring clockwise increases the setting; turning it counter clockwise reduces the setting.

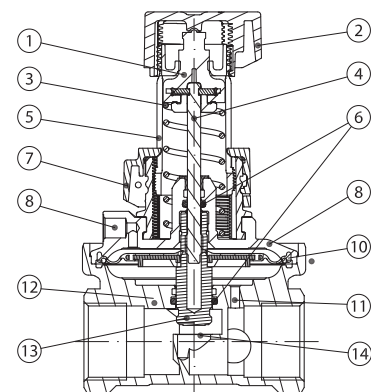

Fig. 6 ASV-PV

1. Handle with setting scale
2. Spindle head
3. Rotation lock
4. Test plug
5. Valve top
6. Spindle
7. Impulse tube connection
8. Closing bush
9. Hose connection
10. Rotating measuring station
11. Throttle bush
12. Supporting screw
13. Ball seat
14. Ball
15. Valve body

Partner valves ASV-BD/M are to be used together with the automatic balancing valves ASV-PV to control differential pressure in the risers.

ASV-BD is a combined presetting and shut-off valve with a range of unique features:

- high  $k_v$  values for small pressure losses,
- partner valve position inside or outside the control loop, can even be changed after the valve is already installed and under pressure,
- numeric presetting scale, visible from multiple angles ①,
- easy locking of presetting,
- rotating measuring station ⑩ with built-in test plugs for 3 mm needles,
- drain function via drain connection accessory (Code No. 003Z4096 or 003Z4097) ⑦,
- removable handle for easy mounting,
- shut-off function separated from presetting,
- open-closed colour indicator.

ASV-BD can be used outside or inside the control loop (see chapter Applications for details) dependent on which test plug is open. Configuration is changeable under pressure.

The shut-off function features a ball valve, which only requires a 90 degree turn to shut the valve completely.

ASV-BD valve is supplied with two test plugs for 3 mm needles. A twin bracket enables the user to connect both needles simultaneously.

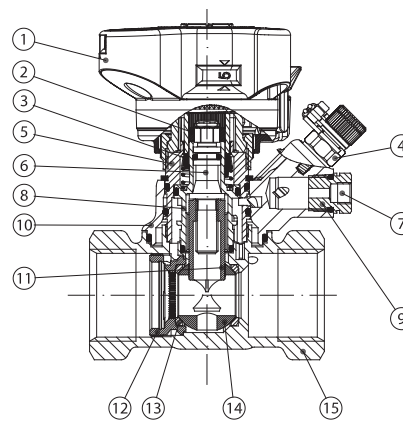

Fig. 7 ASV-BD DN 15-50

**Note:** The screws in PURE version has left handed (reverse) threads.  
**Standard version:** counterclockwise to Drain  
**PURE version:** clockwise to Drain

1. Shut-off handle
2. Shut-off spindle
3. O-rings
4. Valve cone
5. Seat
6. Valve body

ASV-M is designed to shut-off the pipe flow. ASV-M has a connection for an impulse tube to ASV-PV. It can be equipped with test plugs for flow measuring (which are sold separately as accessories).

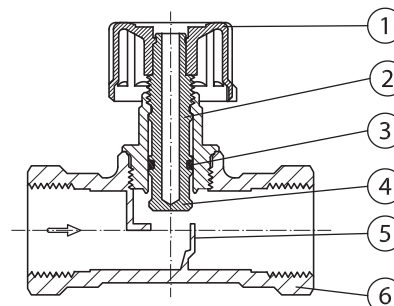

Fig. 8 ASV-M

## Materials

Valve body	Brass	Brass	DZR brass	Brass	Ecobrace (CW724R)	Ecobrace (CW724R)
Cone	DZR brass	Brass	Brass	Brass	Ecobrace (CW724R)	Ecobrace (CW724R)
Membrane / O-rings	EPDM	EPDM	EPDM	EPDM	EPDM	EPDM
Spring	Patent wire	-	-	-	Patent wire	-
Ball	-	-	Brass / chromium plated	Brass / chromium plated	-	Ecobrace (CW724R) / chromium plated

## Fittings

Nut	brass
Tailpiece welding	steel
Tailpiece threaded	brass

For ordering see **Accessories and spare parts table**.

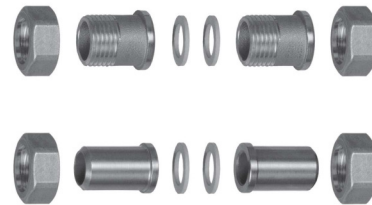

## Pressure and temperature data

### Pressure testing

Max. test pressure: 25 bar

When pressure testing the system the impulse tube should be connected and all partner valves should be open.

### Measurement of flow and differential pressure

Differential pressure across the ASV-BD valve can be taken by:

- Measuring: by using Danfoss PFM or any other measuring device. ASV-BD is equipped with two test plugs so that the differential pressure across the valve can be measured.
- Use ASV-BD  $k_v$ -signal value if valve data is entered manually. See appendix B.
- Using the pressure drop graph for ASV-BD (**Appendix A**, fig B), where the actual differential pressure across a valve can be converted to actual flow.

**Note:** When measuring sized flow, all radiator thermostat sensors should be fully open (nominal flow).

### Measurement of differential pressure ( $\Delta p$ ) across riser.

Fit a measuring connector (Code No. 003L8143) on the ASV-PV balancing valve drain connection (DN 15-50). Measurements should be taken between :

- the test plug at ASV-BD valve (blue test plug needs to be open-factory position) and the measuring connector on the ASV-PV.
- the test plug at ASV-M valve (port B) and the measuring connector on the ASV-PV.

### Flow verification (in case ASV-BD is used outside the controlled loop)

Use the following procedure:

1. Blue test plug on ASV-BD needs to be open (factory position).
2. ASV-BD setting is at maximum value.
3. Flow can be measured using Danfoss PFM or other brand of measuring instrument.
4. If pressure drop across the valve is too low for reliable flow measurement, ASV-BD needs to be set to lower setting to achieve high enough pressure drop across the valve.

### Pump optimization

$\Delta p$  measurement can also be used to optimize the pump head – it is important to measure on the last (index) riser of the system and at full system load (all TRV's fully open).

The pump head can be decreased until no more than the minimal required pressure is available on the last riser.

With observation of the  $\Delta p$  while reducing the pump speed, the goal is to optimize the pump at the lowest possible setting while making sure that enough pressure and flow is available.

### Dimensions

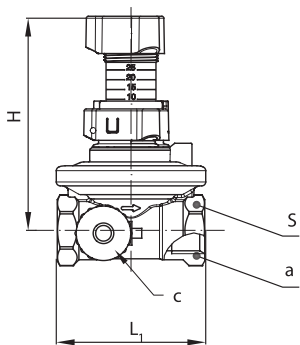

Internal thread (ISO 7/1)

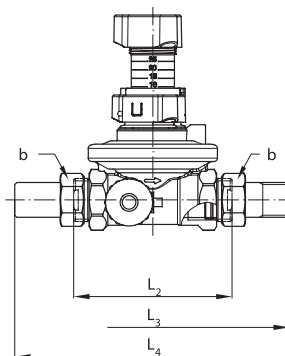

External thread (ISO 228/1)

### ASV-PV

DN	L <sub>1</sub>	L <sub>2</sub>	L <sub>3</sub>	L <sub>4</sub>	H <sup>1)</sup>	H <sub>min</sub> <sup>2)</sup>	H <sub>max</sub> <sup>3)</sup>	S	a	b	c
	mm								ISO 7/1	ISO 228/1	
15	65	85	140	159	111	96	116	27	Rp 1/2	G 3/4 A	G 3/4 A
20	75	100	161	184	111	96	116	32	Rp 3/4	G 1 A	
25	85	110	180	194	136	113	143	41	Rp 1	G 1 1/4 A	
32	95	121	206	184	191	183	213	50	Rp 1 1/4	G 1 1/2 A	
40	100	136	242	220	200	192	222	55	Rp 1 1/2	G 1 1/2 A	
50	130	166	280	250	203	195	225	67	Rp 2	G 2 3/4 A	

<sup>1)</sup> at 10 kPa or 30 kPa factory setting

<sup>2)</sup> at 25 kPa or 60 kPa setting

<sup>3)</sup> at 5 kPa or 20 kPa setting

ASV-BD

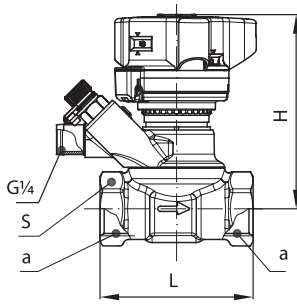

DN	L	H	S	a
	mm			ISO 228/1
15	65	92	27	G $\frac{1}{2}$
20	75	95	32	G $\frac{3}{4}$
25	85	98	41	G 1
32	95	121	50	G $1\frac{1}{4}$
40	100	125	55	G $1\frac{1}{2}$
50	130	129	67	G 2

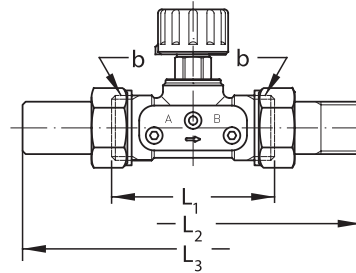
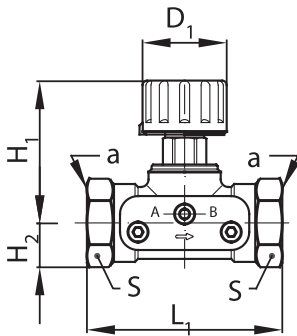

ASV-M

DN	L $_1$	L $_2$	L $_3$	H $_1$	H $_2$	D $_1$	S	a	b
	mm							ISO 7/1	ISO 228/1
15	65	120	139	48	15	28	27	Rp $\frac{1}{2}$	G $\frac{3}{4}$ A
20	75	136	159	60	18	35	32	Rp $\frac{3}{4}$	G 1 A
25	85	155	169	75	23	45	41	Rp 1	G $1\frac{1}{4}$ A
32	95	172	179	95	29	55	50	Rp $1\frac{1}{4}$	G $1\frac{1}{2}$ A
40	100	206	184	100	31	55	55	Rp $1\frac{1}{2}$	G $1\frac{3}{4}$ A
50	130	246	214	106	38	55	67	-	G $2\frac{1}{4}$ A

**Dimensions - insulation**

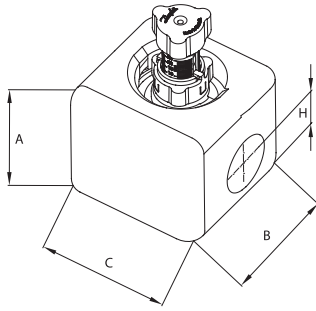

**ASV-PV**

DN	A	B	C	H
	mm			
15	95	120	110	36
20				
25	110	130	130	42
32	135	145	140	50
40	155	165	170	59
50				

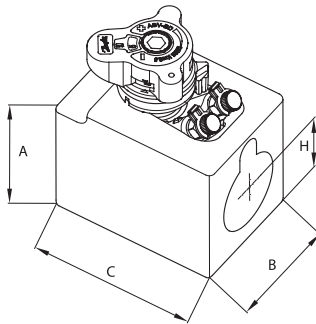

**ASV-BD**

DN	A	B	C	H
	mm			
15	79	85	122	31
20	84	85	122	33
25	99	85	122	45
32	132	85	185	55
40	138	130	185	57
50	138	126	185	53

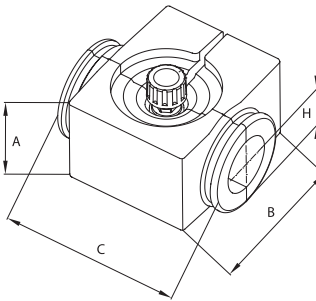

**ASV-M**

DN	A	B	C	H
	mm			
15	61	110	111	30
20	76	120	136	38
25	100	135	155	50
32	118	148	160	60
40	118	148	180	60

## Installation

ASV-PV is intended for indoor installation. It should be installed in the return pipe with flow in the direction of the arrow on the valve body. Partner valves (ASV-M/BD) should be installed in the flow pipe, with flow in the direction of the arrow on the valve body. The impulse tube should be installed between partner valve and ASV-PV.

The system can be filled via the ASV-PV's integrated drain valve or the flushing accessory (003Z7850). Ensure the system is ventilated at its highest point.

The impulse tube should be flushed through from flow pipe direction before connection to ASV-PV.

Small installation dimensions enable easy installation of ASV valves even in very limited space. A 90° angle between all service features (shut-off, draining, setting, measuring) allows an easy access under any installing condition.

### Draining

The drain connection on ASV-PV or ASV-BD can be used for water tapping and filling.

Use the following procedure to drain via ASV-BD valve:

1. Close opened test plug.
2. Remove the impulse tube.
3. Dismount the hose connection.
4. Fit drain connection accessory (Code No. **003Z4096** or **003Z4097**).
5. Blue test plug opens the outlet while red test plug opens the inlet. Make sure not to use more than max. 3 turns. Drain connection and test plugs can rotate to any position.

### Trouble shooting:

Check the following if the riser valve does not function correctly:

1. Is the flow direction through the valves correct?
2. Is the impulse tube fitted correctly?
3. Is the partner valve set according to wished system setup?
4. Are the valves shut-off open?
5. Are the valves and impulse tube flushed and de-aired?
6. Is the available differential pressure within the ASV-PV range?

### Installation heights

To ease installation of ASV-PV where space is limited, installation heights can be reduced.

Valve is turned to max setting and blue knob can be removed.

For advanced users: see installation guide for ASV-PV upgrade kit for further information on installation heights.

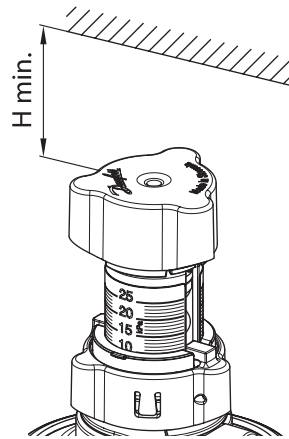

DN	H min.
15	80
20	80
25	100
32	150
40	150
50	150

## Service

### Troubleshooting

Check the following if the riser valve does not function correctly:

1. Is the flow direction through the valve correct?
2. Is the impulse tube fitted correctly and are any test plugs open?
3. Is the valve shut-off open?

## Certificates, declarations and approvals

The list contains all certificates, declarations, and approvals for this product type. Individual code number may have some or all of these approvals, and certain local approvals may not appear on the list.

When you click on the link you will be directed to the latest version of the 'Declaration of Conformity'. Products developed and sold before this date of issue conform to the directives/standards in force at the time of their sale.

Approval type	Title	Certification body	Approval topic
Manufacturer's Declaration	<a href="#">Danfoss MD BF20072023-en02.01</a>	Danfoss	Pressure, PED, EU RoHS
UA Declaration	<a href="#">Danfoss UA 2023-01-23 MTC ASV RA FH RAX PL03 PL28</a>	Danfoss	Pressure, PED
Pressure Safety Certificate	<a href="#">LLC CDC EURO-TYSK UA.TR.089.1011.01-22</a>	LLC CDC EURO TYSK - Ukraine	Pressure, PED
Export Control Declaration	<a href="#">Automatic balancing and Pressure independent control valves</a>	Danfoss	

## Tender text

### ASV-PV DN 15-50 (4th gen.)

Branch should be balanced with a differential pressure controller for dynamic hydronic balance, with following characteristics:

- Valve should keep stable differential pressure across the branch by membrane driven controller
- Valve should have variable Differential pressure setting.
- Minimum needed differential pressure over the valve should not be higher than 10 kPa, independently from Dp setting
- Valve should have metal to metal (valve cone and seat) sealing to ensure optimal performance of differential pressure control at low flows
- Differential pressure setting should be linear via visual scale and without tool, locking function should be integrated to prevent unauthorized change of setting
- The setting range should be adaptable via spring replacement. Spring should be exchangeable under pressure
- Setting range on spring should not be more than 40 kPa to achieve best accuracy
- Valve should provide differential pressure setting range fit to application to ensure optimal system performance (such as 5-25 kPa setting range for radiator based systems)
- Valve capacity per valve size should cover flow range according to VDI 2073 Standards (with water velocity of up 0.8 m/s)
- Valve should have shut-off function separated from the setting mechanism. Shut-off service function should be possible to do by hand / without tool
- Drain function should be integrated in valve
- Valves should have integrated flushing service function. Flushing can be done with flushing accessory
- Valve should be delivered with impulse tube. Inner diameter of impulse tube should not be bigger than 1.2 mm to ensure optimal performance within the system
- Valve should be delivered with thermal insulation caps, up to 120°C
- Valve should be delivered in reliable packaging for safe transport and handling

### Product characteristics:

1. Pressure class: PN 16
2. Temperature range: 0 ... +120 °C
3. Connection size: DN 15-50
4. Connection type: Internal thread ISO 7/1 (DN 15-50), External thread ISO 228/1 (DN 15-50)
5.  $\Delta p$  setting range: 5-25 kPa, 20-60 kPa and 20-80 kPa
6. Max differential pressure across valve: 2.5 bar
7. Installation: differential pressure controller should mounted on return pipe with connection via impulse tube to supply pipe.

## Contact details

### Online support

Danfoss offers a wide range of support along with our products, including digital information, software, mobile apps and expert guidance. See the possibilities below.



#### The Danfoss Design center

Discover the Design Center, our advanced digital platform that streamlines product selection. With integrated tools and enhanced type pages, it's simpler than ever to access product information and documentation, and to select the right products. Check the availability of Danfoss products at partner locations and enjoy seamless transitions from selection to purchase with our basket-to-basket functionality. Whether you're buying from our distributors or directly from the Product Store, the Design Center simplifies your experience. Learn more at: [designcenter.danfoss.com](https://designcenter.danfoss.com).



#### The Danfoss product store

The Danfoss Product Store is a one-stop shop available 24/7 for our customers, no matter where you are in the world or what area of industry you work in. Browse our catalog, check product details and documentation, view your prices and product availability, and quickly finalize your purchase. Start browsing at: [store.danfoss.com](https://store.danfoss.com).



#### Danfoss Partner Portal/Product Data tool

Designed to support you with easy access to product data extracts, essential resources, tools, and information. The Partner Portal provides a centralized hub for product documentation, training materials, marketing assets, and technical support, ensuring you have everything you need to succeed and grow your business with Danfoss. The Partner Portal is available 24/7 at: [partner.danfoss.com](https://partner.danfoss.com) and is ready to support your business.



#### Find technical documentation

Find technical documentation you need to get your project up running. Get direct access to our official collection of data sheets, certificates and declarations, manuals and guides, 3D models and drawings, case stories, brochures, and much more. Start searching now at: [documentation.danfoss.com](https://documentation.danfoss.com).



#### Danfoss Learning

Danfoss Learning is a free online learning platform. It features courses and materials specifically designed to help engineers, installers, service technicians, and wholesalers better understand the products, applications industry topics, and trends that will help you do your job better. Find your local Danfoss website here: [learning.danfoss.com](https://learning.danfoss.com).



#### Get local information and support

Local Danfoss websites are the main sources for help and information about our company and products. Find product availability, get the latest regional news, or connect with a nearby expert - all in your own language. Find your local Danfoss website here: [danfoss.com](https://danfoss.com).

#### Danfoss A/S

Climate Solutions . danfoss.com . +45 7488 2222

---

Any information, including, but not limited to information on selection of product, its application or use, product design, weight, dimensions, capacity or any other technical data in product manuals, catalogues description, advertisements, etc. and whether made available in writing, orally, electronically, online or via download, shall be considered informative, and is only binding if and to the extent, explicit reference is made in a quotation or order confirmation. Danfoss cannot accept any responsibility for possible errors in catalogues, brochures, videos and other material. Danfoss reserves the right to alter its products without notice. This also applies to products ordered but not delivered provided that such alterations can be made without changes to form, fit or function of the products. All trademarks in this material are property of Danfoss A/S or Danfoss group companies. Danfoss and the Danfoss logo are trademarks of Danfoss A/S. All rights reserved.

---