



Manual balancing

MSV-F2

PN 16/25, DN 15-400

Description

MSV-F2 valves are manual presetting valves with flanged connections. They are used for balancing the flow in heating and cooling installations.

The valves have a position indicator and stroke limiter as standard. The hand wheel of the valve is integrated with the stroke limiter.

The setting can be locked. Valve characteristics are set up in measuring device PFM 1000/ PFM 100. Valves are free of asbestos.

Shut-off function.

Features & benefits

- DN 15 - 400
- PN 16: Flow temperature: -10°C ... 130°C
- PN 25: Flow temperature: -10°C ... 150°C
- Valves can be mounted in the supply or return pipe.

Applications

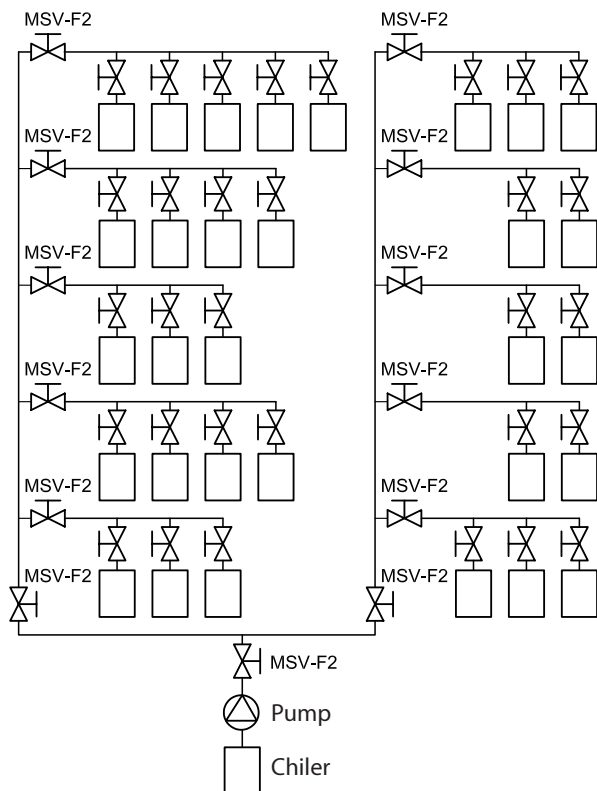

Cooling installation (flow) with manual presetting valves. In order to balance the cooling installation manual presetting valves should be mounted on each terminal unit, branch and riser (LENO™ MSV-BD).

Ordering

Product code numbers

MSV-F2 valves - PN 16

DN (mm)	k_{vs} (m ³ /h)	T _{max.} (°C)	PN (bar)	Code No. (with needle test plugs)
15	3.1	130	16	003Z1085
20	6.3			003Z1086
25	9.0			003Z1087
32	15.5			003Z1088
40	32.3			003Z1089
50	53.8			003Z1061
65	93.4			003Z1062
80	122.3			003Z1063
100	200.0			003Z1064
125	304.4			003Z1065
150	400.8			003Z1066
200	850			003Z1140
250	1207			003Z1141
300	1636			003Z1142
350	2300			003Z1143
400	3500			003Z1144

MSV-F2 valves - PN 25

DN (mm)	k_{vs} (m ³ /h)	T _{max.} (°C)	PN (bar)	Code No. (with needle test plugs)
15	3.1	150	25	003Z1092
20	6.3			003Z1093
25	9.0			003Z1094
32	15.5			003Z1095
40	32.3			003Z1096
50	53.8			003Z1070
65	93.4			003Z1071
80	122.3			003Z1072
100	200.0			003Z1073
125	304.4			003Z1074
150	400.8			003Z1075
200	850			003Z1145
250	1207			003Z1146
300	1636			003Z1147
350	2300			003Z1148
400	3500			003Z1149

Accessories code numbers

Type	Code No.
Standard test plugs with O-ring, 2 pcs.	003Z0104
Extension piece for test plugs 45 mm, 2 pcs.	003Z0103
Extended test plugs mounted under pressure, 2 pcs.	003Z3946
Flow measuring instrument PFM100 (10bar)	003L8260
Flow measuring instrument PFM1000 (10 bar)	003Z8260
Flow measuring instrument PFM1000 (20 bar)	003Z8261

Type		Code No.
Hand-wheel	DN 15-50	003Z0179
	DN 65-150	003Z0180
	DN 200-250	003Z1180
	DN 300	003Z1181
	DN 350	003Z1182
	DN 400	003Z1183

Functions

Operation

Flow diagrams

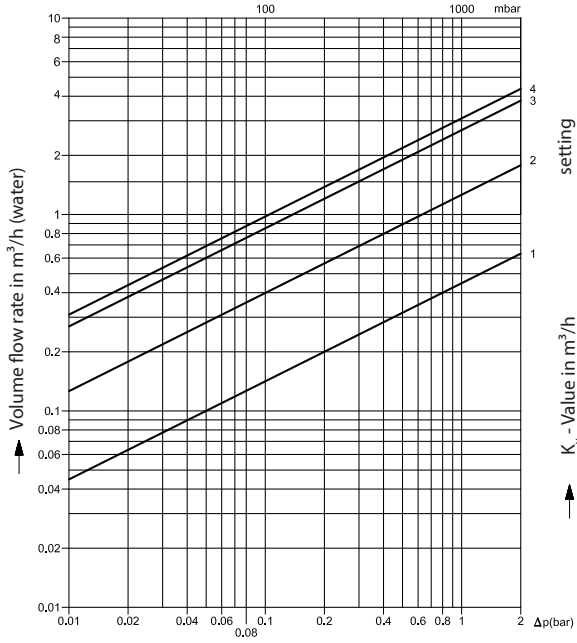

Pressure lost in Pascal (10 Pascal 1mm H₂O=9.8066 Pa) 1 bar=0.1 MPa=10 Pa⁵

DN 15 / PN 16 / PN 25

Setting	k_v - value
1	0.45
2	1.26
3	2.73
4	3.09

Max. permissible differential pressure in throttling function 1.5/2.0 bar.

Max. permissible flow speed: $\leq 4 \text{ m/s}$

Condition: The flow must be free of cavitation.

Flow characteristic

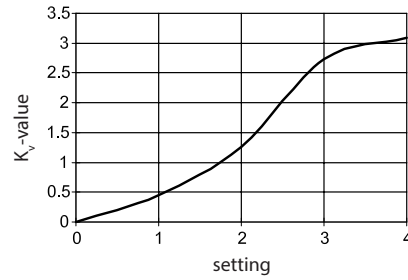

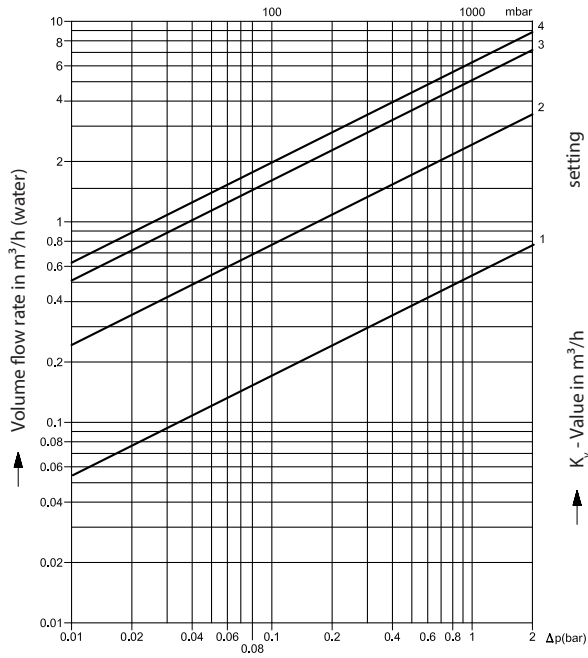

Pressure lost in Pascal (10 Pascal 1mm H₂O=9.8066 Pa) 1 bar=0.1 MPa=10 Pa⁵

DN 20 / PN 16 / PN 25

Setting	k _v - value
1	0.54
2	2.48
3	5.11
4	6.26

Max. permissible differential pressure in throttling function 1.5/2.0 bar.

Max. permissible flow speed: ≤ 4 m/s

Condition: The flow must be free of cavitation.

Flow characteristic

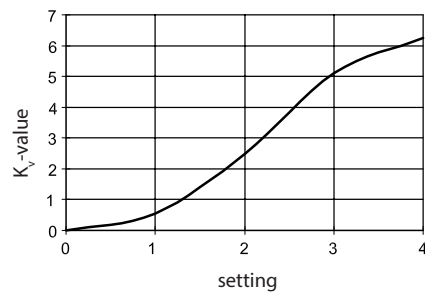

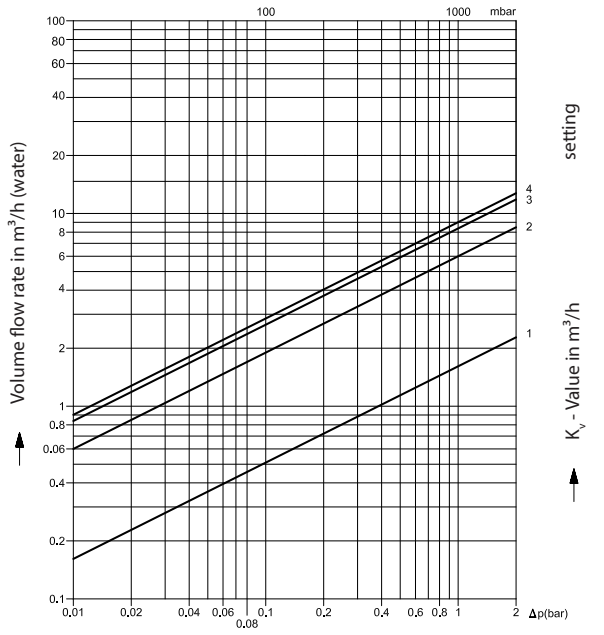

DN 25 / PN 16 / PN 25

Setting	k _v - value
1	1.61
2	6.0
3	8.38
4	9.01

Max. permissible differential pressure in throttling function 1.5/2.0 bar.

Max. permissible flow speed: ≤ 4 m/s

Condition: The flow must be free of cavitation.

Flow characteristic

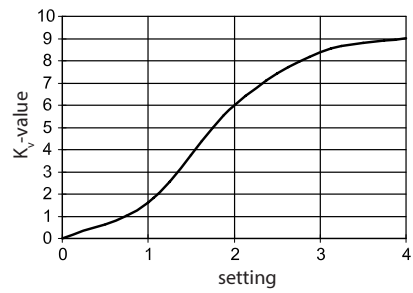

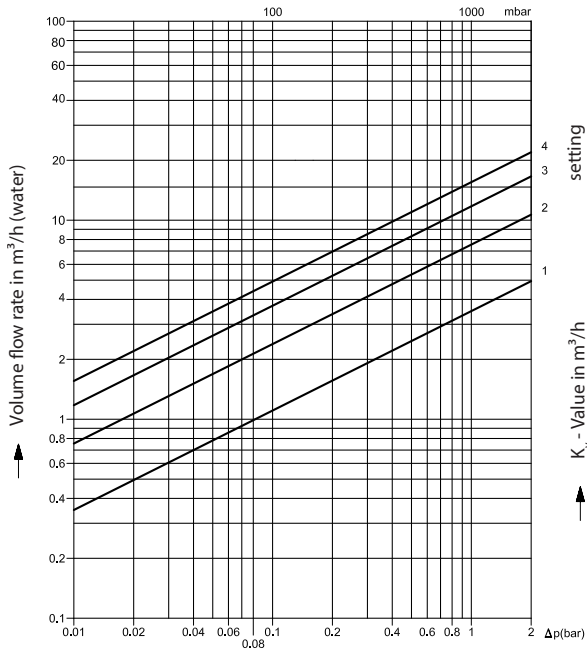

Pressure lost in Pascal (10 Pascal 1mm H₂O=9.8066 Pa) 1 bar=0.1 MPa=10 Pa⁵

DN 32 / PN 16 / PN 25

Setting	k _v -value
1	3.53
2	7.56
3	12.32
4	15.54

Max. permissible differential pressure in throttling function 1.5/2.0 bar.

Max. permissible flow speed: ≤ 4 m/s

Condition: The flow must be free of cavitation.

Flow characteristic

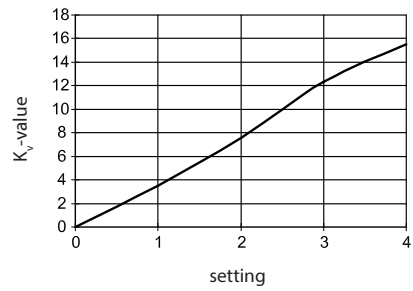

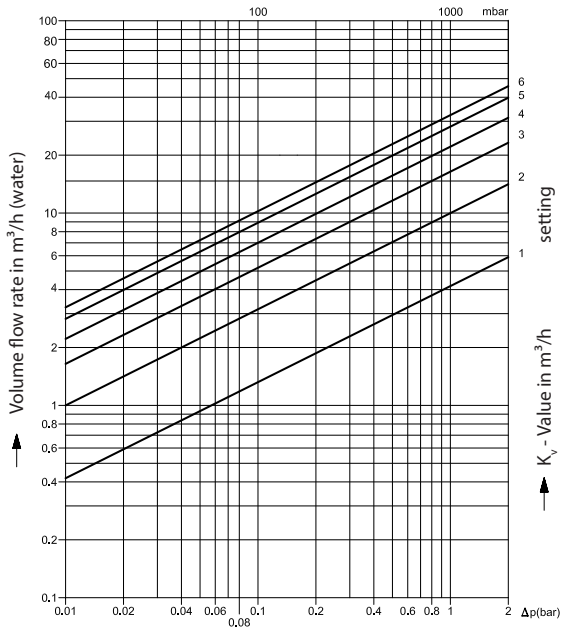

Pressure lost in Pascal (10 Pascal 1mm H₂O=9.8066 Pa) 1 bar=0.1 MPa=10 Pa⁵

DN 40 / PN 16 / PN 25

Setting	k _v - value
1	4.19
2	9.98
3	16.42
4	22.13
5	28.14
6	32.31

Max. permissible differential pressure in throttling function
1.5/2.0 bar.

Max. permissible flow speed: ≤ 4 m/s

Condition: The flow must be free of cavitation.

Flow characteristic

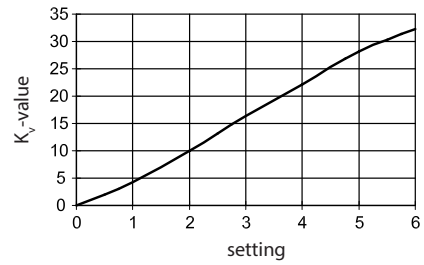

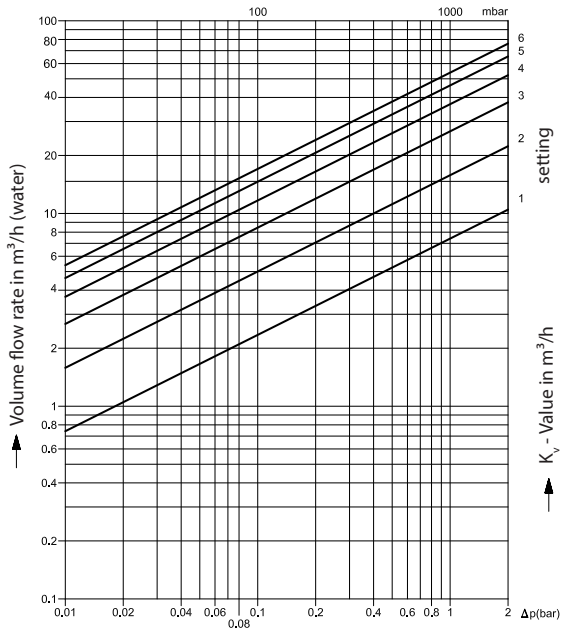

Pressure lost in Pascal (10 Pascal 1mm H₂O=9.8066 Pa) 1 bar=0.1 MPa=10 Pa⁵

DN 50 / PN 16 / PN 25

Setting	k _v - value
1	7.4
2	15.8
3	26.7
4	36.9
5	46.2
6	53.8

Max. permissible differential pressure in throttling function 1.5/2.0 bar.

Max. permissible flow speed: ≤ 4 m/s

Condition: The flow must be free of cavitation.

Flow characteristic

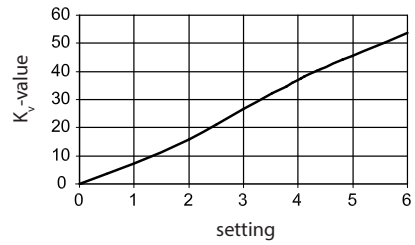

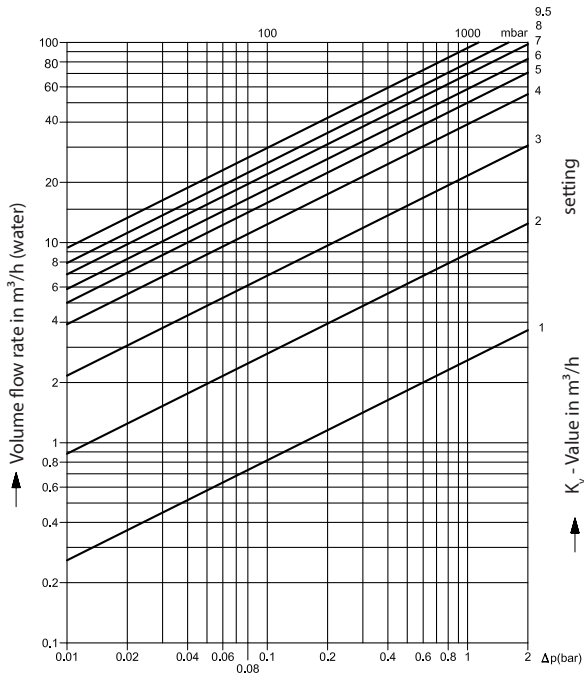

Pressure lost in Pascal (10 Pascal 1mm H₂O=9.8066 Pa) 1 bar=0.1 MPa=10 Pa⁵

DN 65 / PN 16 / PN 25

Setting	k _v - value
1	2.6
2	8.8
3	21.6
4	39.0
5	49.8
6	58.5
7	69.3
8	79.0
9	87.8
9.5	93.4

Max. permissible differential pressure in throttling function 1.5/2.0 bar.

Max. permissible flow speed: ≤ 4 m/s

Condition: The flow must be free of cavitation.

Flow characteristic

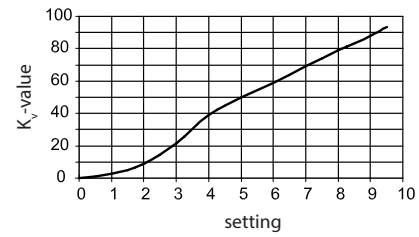

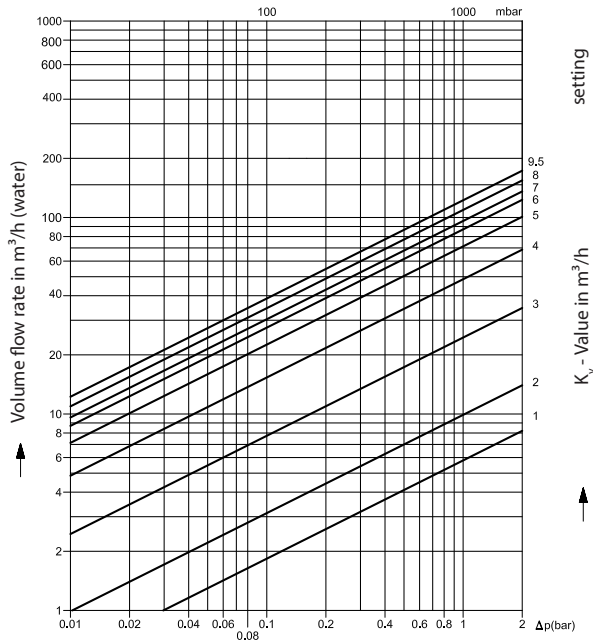

Pressure lost in Pascal (10 Pascal 1mm H₂O=9.8066 Pa) 1 bar=0.1 MPa=10 Pa⁵

DN 80 / PN 16 / PN 25

Setting	k _v - value
1	5.8
2	9.9
3	24.5
4	48.5
5	71.3
6	87.0
7	96.4
8	109.3
9.5	122.3

Max. permissible differential pressure in throttling function 1.5/2.0 bar.

Max. permissible flow speed: ≤ 4 m/s

Condition: The flow must be free of cavitation.

Flow characteristic

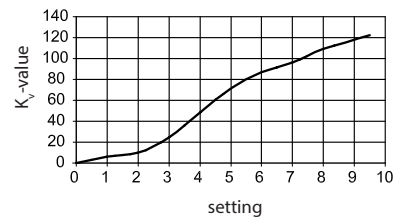

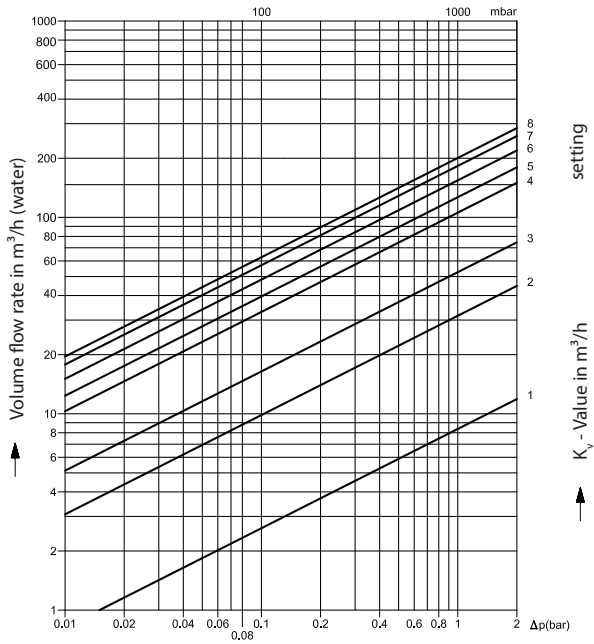

Pressure lost in Pascal (10 Pascal 1mm H₂O=9.8066 Pa) 1 bar=0.1 MPa=10 Pa⁵

DN 100 / PN 16 / PN 25

Setting	k _v - value
1	8.3
2	32.4
3	72.9
4	107.2
5	128.2
6	152.8
7	180.0
8	200.0

Max. permissible differential pressure in throttling function 1.5/2.0 bar.

Max. permissible flow speed: ≤ 4 m/s

Condition: The flow must be free of cavitation.

Flow characteristic

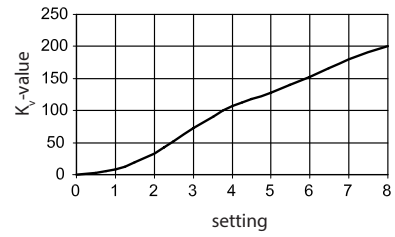

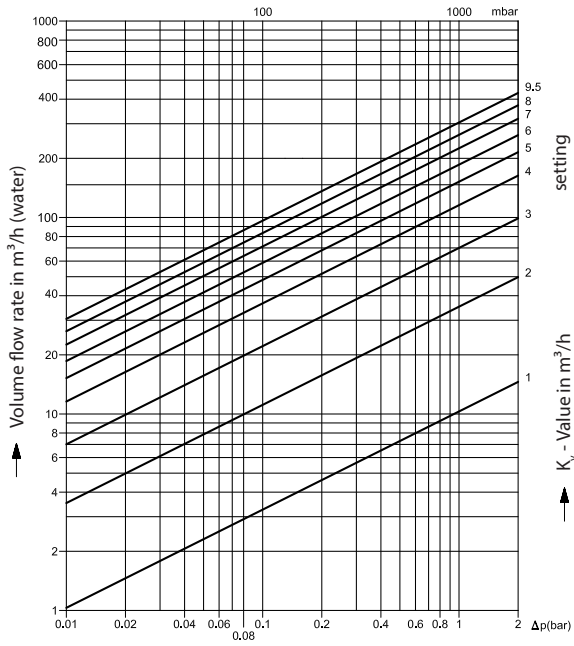

Pressure lost in Pascal (10 Pascal 1mm H₂O=9.8066 Pa) 1 bar=0.1 MPa=10 Pa⁵

DN 125 / PN 16 / PN 25

Setting	k _v - value
1	10.3
2	35.4
3	73.0
4	114.9
5	150.5
6	185.2
7	225.1
8	261.1
9	294.2
9.5	304.4

Max. permissible differential pressure in throttling function 1.5/2.0 bar.

Max. permissible flow speed: ≤ 4 m/s

Condition: The flow must be free of cavitation.

Flow characteristic

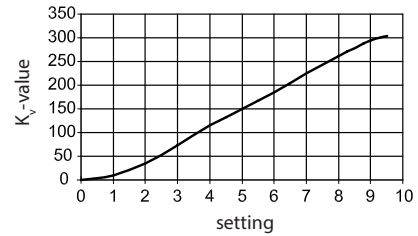

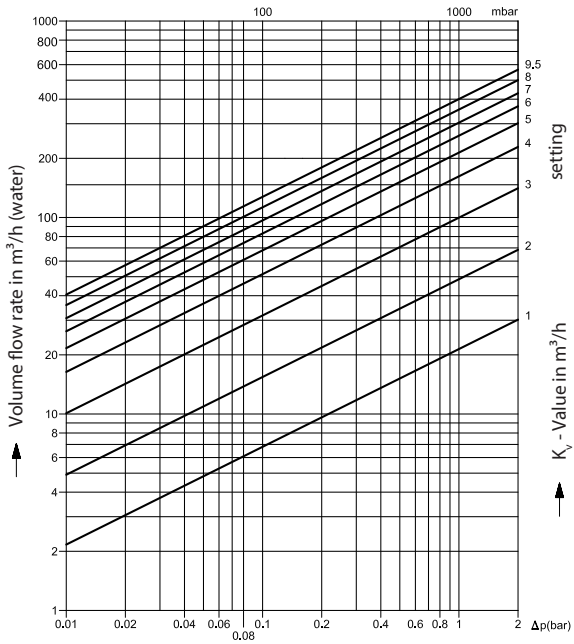

Pressure lost in Pascal (10 Pascal 1mm H₂O=9.8066 Pa) 1 bar=0.1 MPa=10 Pa⁵

DN 150 / PN 16 / PN 25

Setting	k _v - value
1	21.4
2	48.5
3	99.8
4	162.0
5	214.0
6	260.9
7	304.1
8	354.6
9.5	400.8

Max. permissible differential pressure in throttling function 1.5/2.0 bar.

Max. permissible flow speed: ≤ 4 m/s

Condition: The flow must be free of cavitation.

Flow characteristic



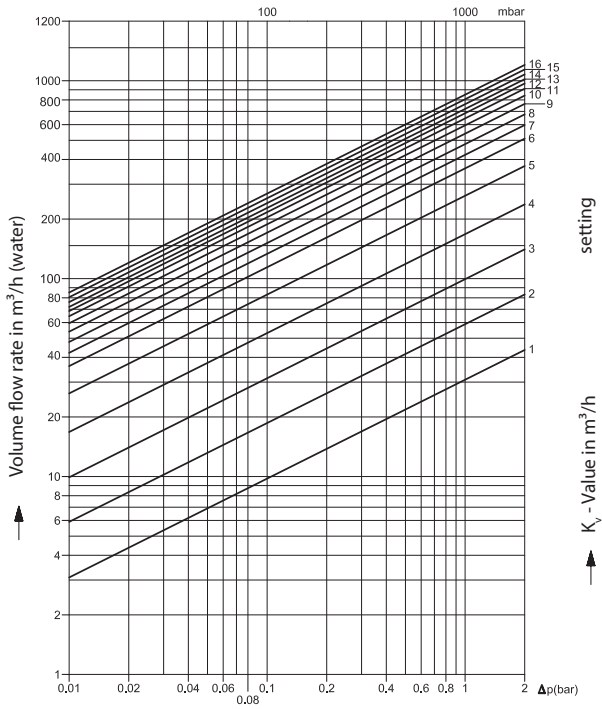

Pressure lost in Pascal (10 Pascal 1mm H₂O=9.8066 Pa) 1 bar=0.1 MPa=10 Pa⁵

DN 200 / PN 16 / PN 25

Setting	k _v - value
1	30.8
2	58.7
3	100
4	170
5	262
6	361
7	423
8	481
9	542
10	597
11	647
12	684
13	722
14	763
15	807
16	850

Max. permissible differential pressure in throttling function 1.5 bar.

Max. permissible flow speed: ≤ 4 m/s

Condition: The flow must be free of cavitation.

Flow characteristic

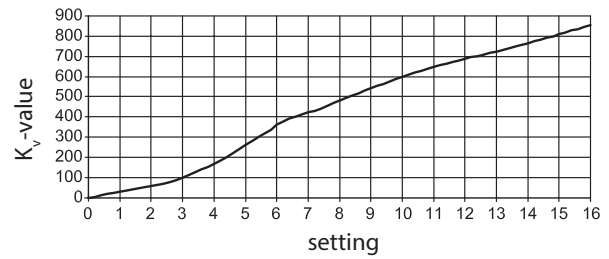

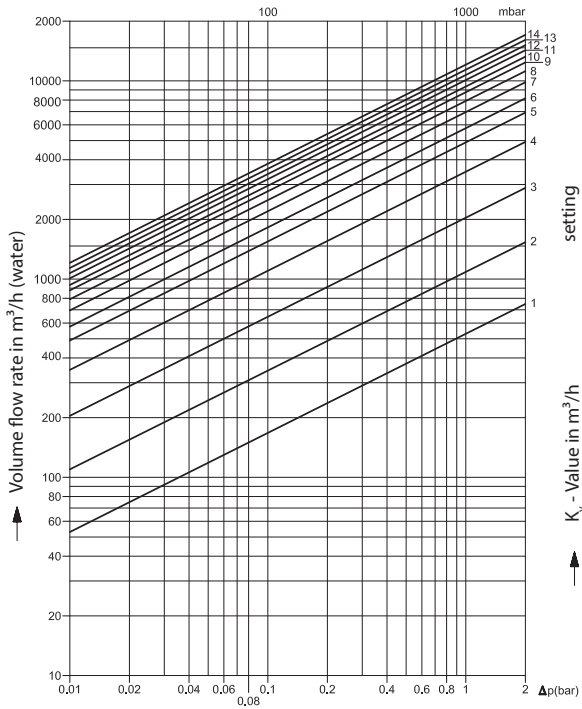

Pressure lost in Pascal (10 Pascal 1mm H₂O=9.8066 Pa) 1 bar=0.1 MPa=10 Pa⁵

DN 250 / PN 16 / PN 25

Setting	k _v - value
1	53.6
2	109
3	207
4	349
5	490
6	580
7	693
8	791
9	877
10	942
11	1012
12	1076
13	1140
14	1211

Max. permissible differential pressure in throttling function 1.5 bar.

Max. permissible flow speed: ≤ 4 m/s

Condition: The flow must be free of cavitation.

Flow characteristic

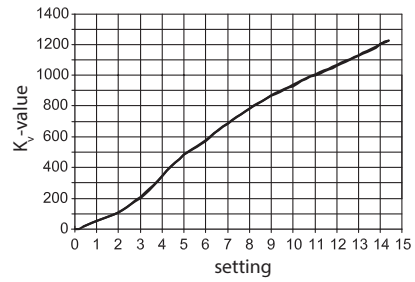

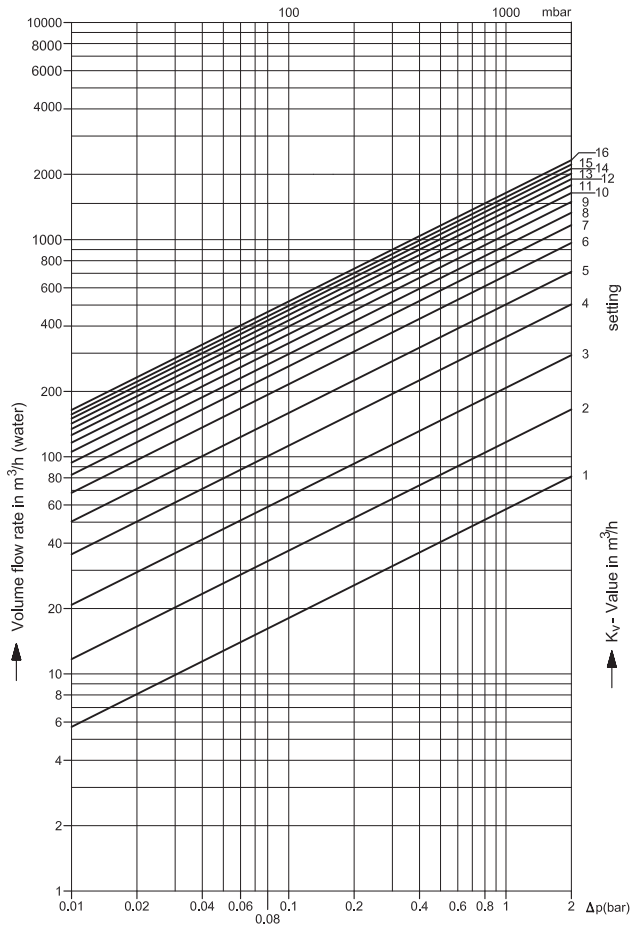

DN 300 / PN 16 / PN 25

Setting	k _v - value
1	57.4
2	117
3	208
4	356
5	503
6	683
7	826
8	940
9	1055
10	1161
11	1260
12	1343
13	1423
14	1500
15	1568
16	1643

Max. permissible differential pressure in throttling function 1.5 bar.

Max. permissible flow speed: ≤ 4 m/s

Condition: The flow must be free of cavitation.

Flow characteristic

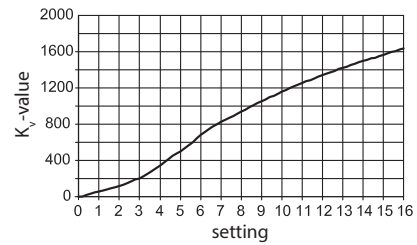

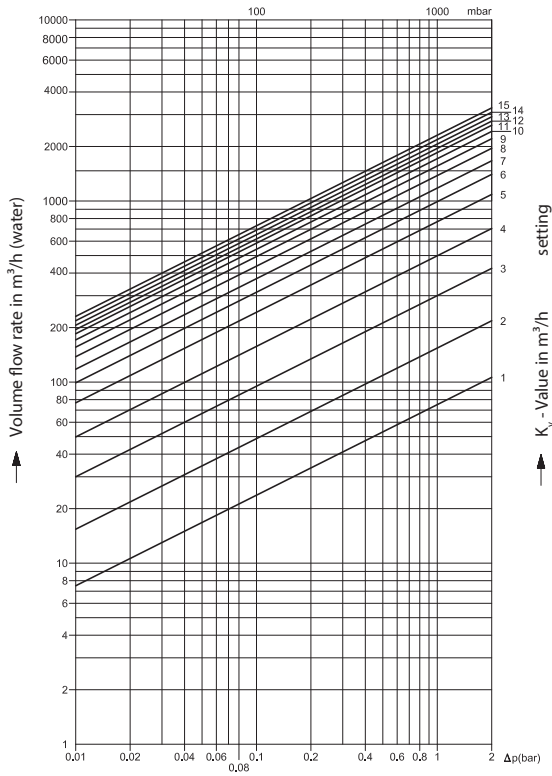

Pressure lost in Pascal (10 Pascal 1 mm H₂O=9.8066 Pa) 1 bar=0.1 MPa=10 Pa⁵

DN 350 / PN 16 / PN 25

Setting	k _v - value
1	75.1
2	154
3	300
4	498
5	768
6	991
7	1177
8	1382

Setting	k _v - value
9	1559
10	1711
11	1848
12	1952
13	2059
14	2182
15	2305

Max. permissible differential pressure in throttling function 1.5 bar.

Max. permissible flow speed: ≤ 4 m/s

Condition: The flow must be free of cavitation.

Flow characteristic

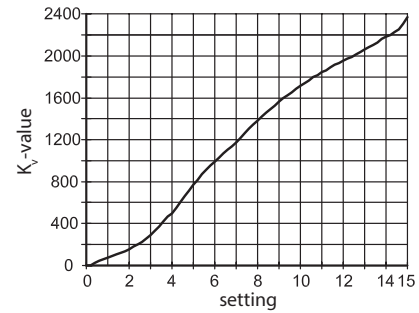

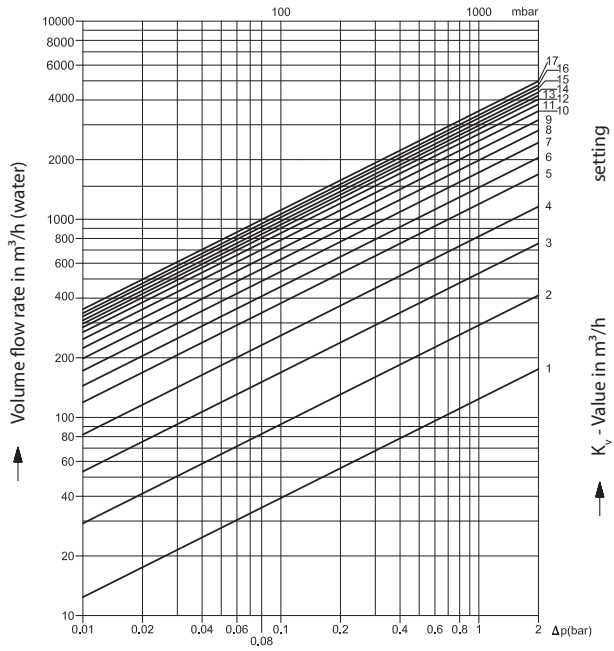

Pressure lost in Pascal (10 Pascal 1mm H₂O=9.8066 Pa) 1 bar=0.1 MPa=10 Pa⁵

DN 400 / PN 16 / PN 25

Setting	k _v - value
0	0
1	124
2	292
3	533
4	819
5	1192
6	1445
7	1720
8	1983

Setting	k _v - value
9	2223
10	2482
11	2682
12	2848
13	2973
14	3093
15	3241
16	3359

Max. permissible differential pressure in throttling function 1.5 bar.

Max. permissible flow speed: ≤ 4 m/s

Condition: The flow must be free of cavitation.

Flow characteristic

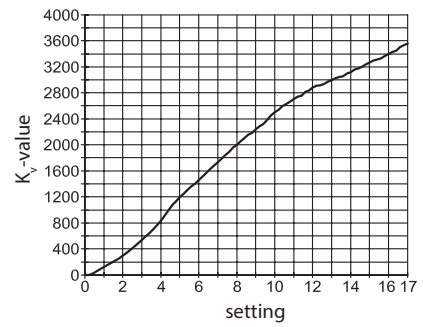



Settings

Ethylenglycol correction factor

Formula	$C_2H_6O_2$
Density at 20 °C	$\rho_{water} = 1 \text{ kg/dm}^3$
	$\rho_{glycol} = 1.338 \text{ kg/dm}^3$

$$Q_{corr} = \frac{Q_{water}}{\sqrt{\text{Share of water} \times \rho_{water} + \text{Share of glycol} \times \rho_{glycol}}}$$

Ethylenglycol part xg (%)	0	10	20	30	40	50	60	70	80	90	100
Correction factor	1.0	0.983	0.968	0.953	0.939	0.925	0.912	0.899	0.887	0.876	0.864

MSV-F2 DN 65

$\Delta p = 0.6 \text{ bar}$

Hand wheel setting: 3.0

Flow: $16.8 \text{ m}^3/\text{h}$

30 % glycol

$Q_{corr} = 16.8 \text{ m}^3/\text{h} \times 0.953 = 16.0 \text{ m}^3/\text{h}$

It refers to all types of valves.

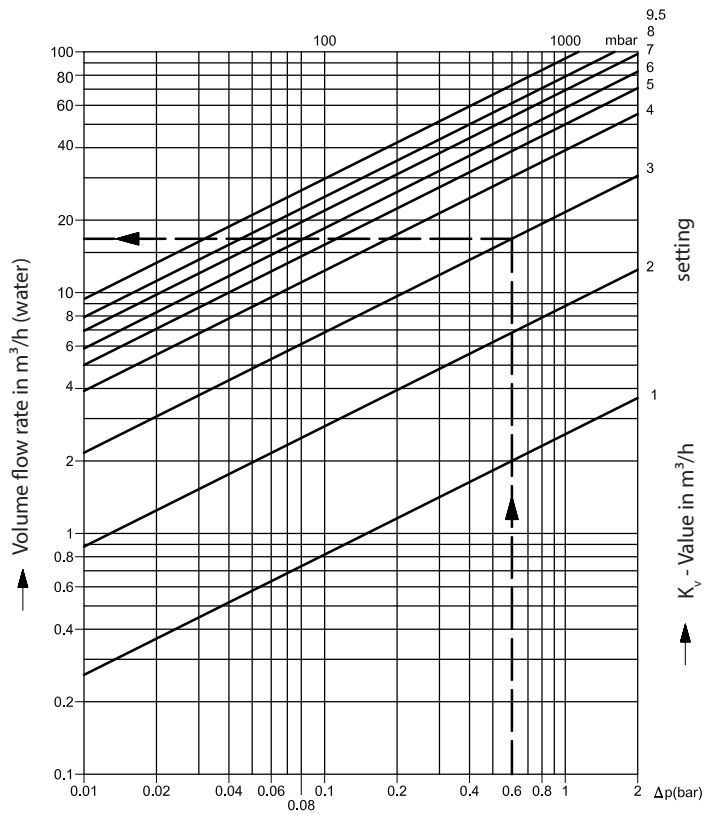

Pressure lost in Pascal (10 Pascal 1mm H₂O=9.8066 Pa) 1 bar=0.1 MPa=10 Pa⁵

Product details

General data

Technical data

MSV-F2 valves - PN 16

Nominal diameter	DN	15	20	25	32	40	50	65	80	100	125	150	200	250	300	350	400
k_{vs}	m ³ /h	3.1	6.3	9.0	15.5	32.3	53.8	93.4	122.3	200.0	304.4	400.8	850	1207	1636	2300	3500
Nominal pressure	bar	16															
Max. pressure drop		1.5															
Leakage rate	Grade A; According to ISO5208, Table 5 (No visible leakage)																
Flow medium	Water and water mixtures with secondary coolants (like glycols ¹⁾) for closed heating and cooling systems																
Max. flow temperature	°C	130															
Connections	Flanges according to EN 1092-2																
Weight	kg	2.3	2.9	3.8	5.6	7.2	9.4	17	21	32	44	56.5	98	153	247	374	525

¹⁾ Please verify compatibility between materials and secondary coolants with supplier.

MSV-F2 valves - PN 25

Nominal diameter	DN	15	20	25	32	40	50	65	80	100	125	150	200	250	300	350	400
k_{vs}	m ³ /h	3.1	6.3	9.0	15.5	32.3	53.8	93.4	122.3	200.0	304.4	400.8	850	1207	1636	2300	3500
Nominal pressure	bar	25															
Max. pressure drop		2.0															
Leakage rate	Grade A; According to ISO5208, Table 5 (No visible leakage)																
Flow medium	Water and water mixtures with secondary coolants (like glycols ¹⁾) for closed heating and cooling systems																
Max. flow temperature	°C	150															
Connections	Flanges according to EN 1092-2																
Weight	kg	2.3	3.0	3.8	5.8	7.2	9.4	17	21	33	44	56.5	107	172	278	420	603

¹⁾ Please verify compatibility between materials and secondary coolants with supplier.



Sizing

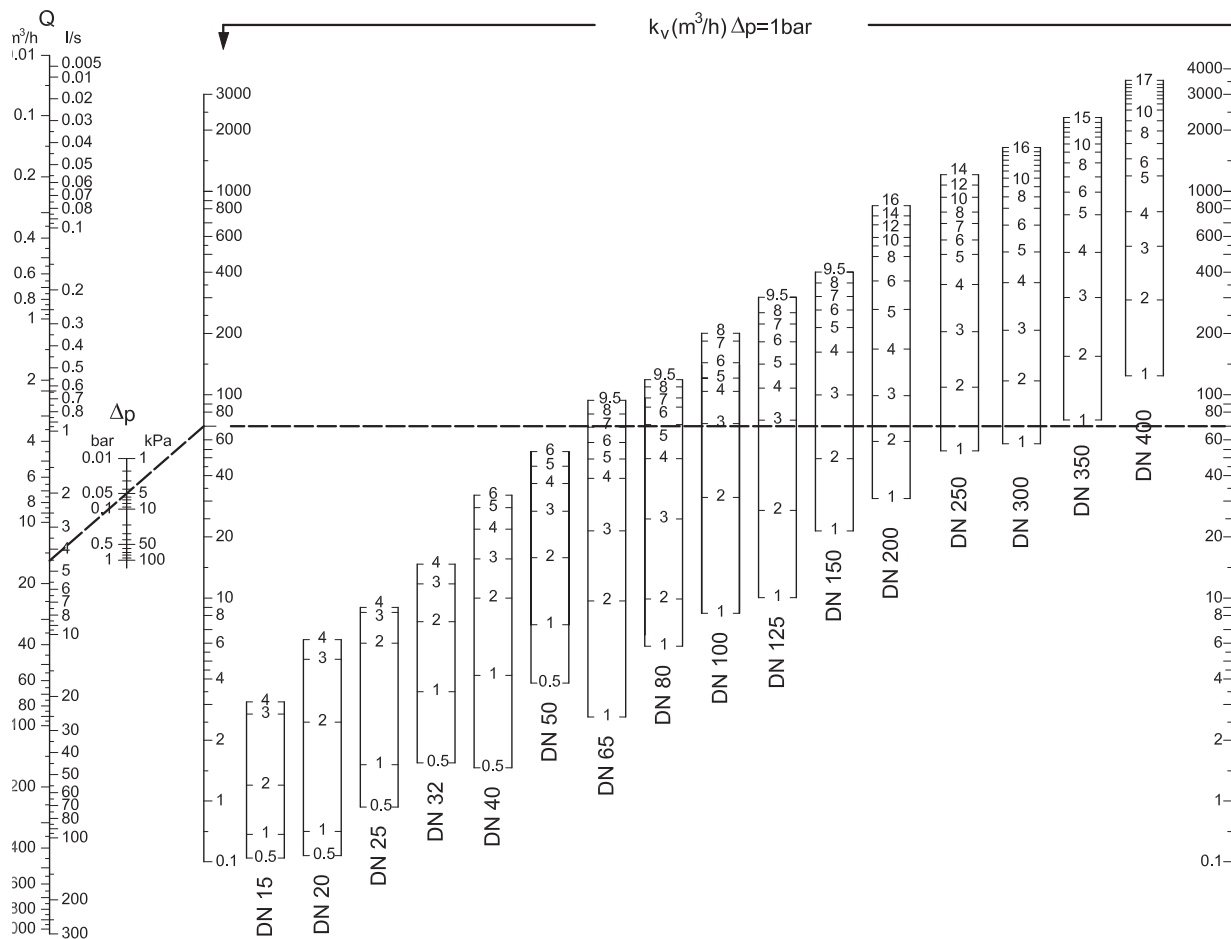

Example:
 MSV-F2 DN 65
 Q = 16 m³/h
 Δp = 5 kPa

Calculation for the valve setting:

Draw a straight line from the desired flow (16 m³/h) through the differential pressure (5 kPa) to k_v scale.

From the k_v value draw a horizontal line. Where it intersects the given valve (DN65) you can find the valve setting.

Result:
 presetting 7.0

Design

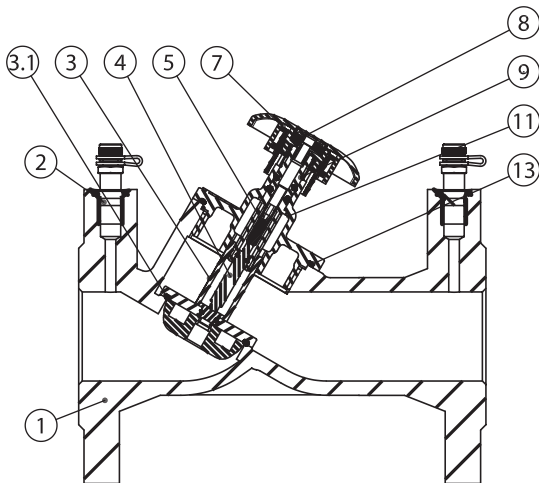

MSV-F2 DN 15-50

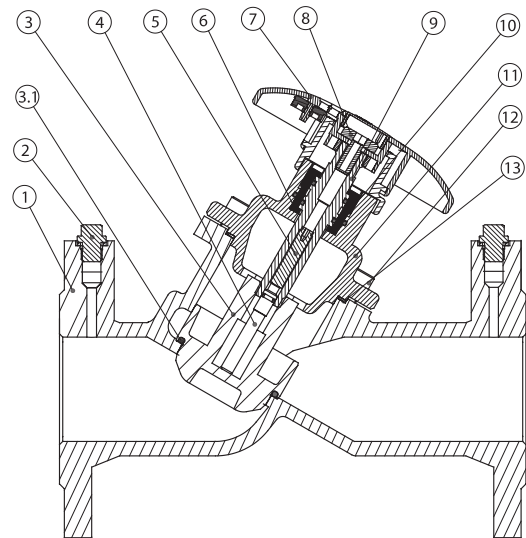

MSV-F2 DN 65-80

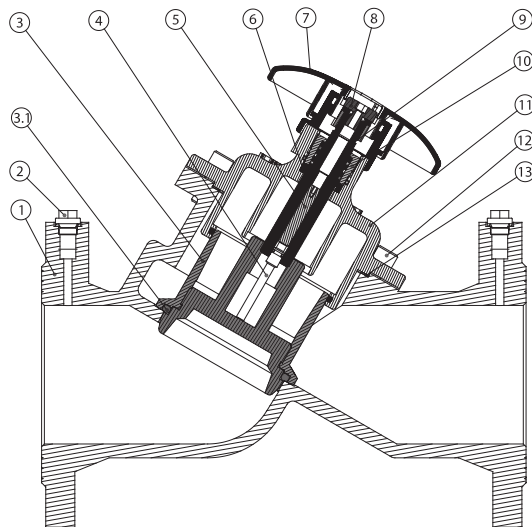

MSV-F2 DN 100-150

1	Body
2	Plug
3	Valve cone
3.1	Seat soft sealing
4	Rod
5	Stroke limiter/Allen screw
6	Gasket

7	Handwheel with digital display - DN 15-150 plastic
8	Fixed screw
9	Spindle
10	Stuffing box
11	Bonnet
12	Allen screw/Hexagon screw
13	Flat gasket

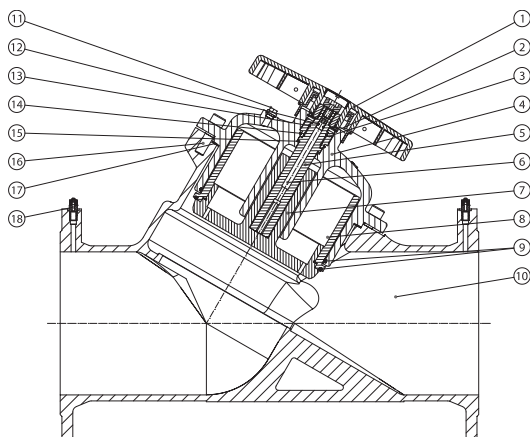

MSV-F2 DN 200-400

1	Handwheel
2	The elastic spring
3	Stuffing box
4	Valve cover
5	Spindle
6	Spindle limiter
7	Cone head
8	Cone attachment
9	O-ring

10	Valve body
11	G1/4" screw
12	O-ring
13	O-ring
14	O-ring
15	Gasket Cu
16	Bolt
17	Gasket
18	Nipple

Materials

MSV-F2 valves - PN 16

Materials	DN	15	20	25	32	40	50	65	80	100	125	150	200	250	300	350	400		
Body		Gray cast iron EN-GJL-250 (GG25)																	
Seat sealing		EPDM																	
Cone		CW602N								Stainless steel	Stainless steel/ CW602N				Casted stainless steel				

MSV-F2 valves - PN 25

Materials	DN	15	20	25	32	40	50	65	80	100	125	150	200	250	300	350	400		
Body		Ductile iron EN-GJS 400-15 (GGG-40)																	
Seat sealing		EPDM																	
Cone		CW602N								Stainless steel	Stainless steel CW602N				Casted stainless steel				

Pressure-temperature classification (flanges according to EN 1092-2)

Material	PN		Temperature		
			-10 °C	120 °C	150 °C
EN-GJS 400-15	25	bar	25	25	24.3

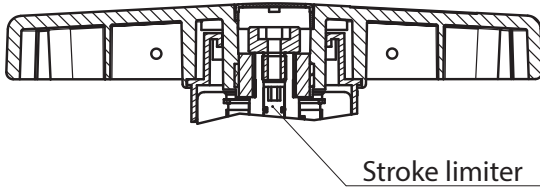

Valves have built in flow limitation

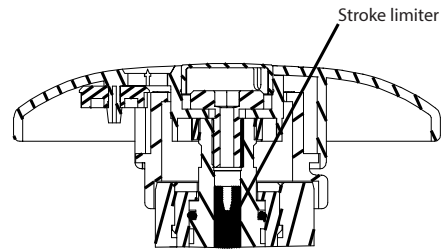

Valves have built in flow limitation

Dimensions

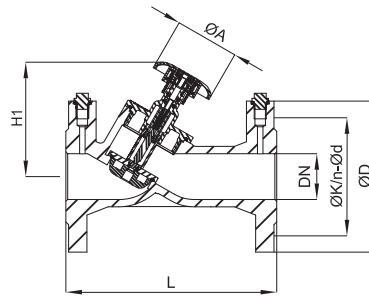

MSV-F2 DN 15-50

DN	L	ØA	H1	PN 16				PN 25			
				ØD	ØK	n x Ød	Weight	ØD	ØK	n x Ød	Weight
				mm				kg			
15	130	78	88	95	65	4x14	2.3	95	65	4x14	2.3
20	150	78	88	105	75	4x14	2.9	105	75	4x14	3.0
25	160	78	100	115	85	4x14	3.8	115	85	4x14	3.8
32	180	78	100	140	100	4x19	5.6	140	100	4x19	5.8
40	200	78	123	150	110	4x19	7.2	150	110	4x19	7.2
50	230	78	125	165	125	4x19	9.4	165	125	4x19	9.4
65	290	140	187	185	145	4x19	17	185	145	4x19	17
80	310	140	205	200	160	8x19	21	200	160	8x19	21

Remark: "n" is number of holes in the flange.

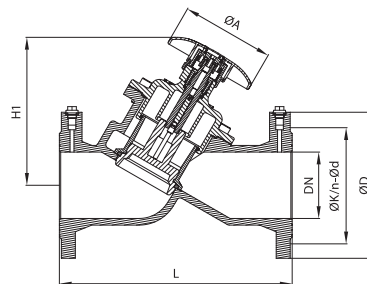

MSV-F2 DN 65-80

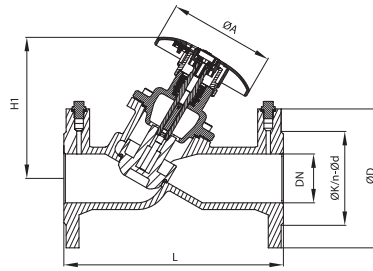

MSV-F2 DN 100-150

DN	L	ØA	H1	PN 16				PN 25			
				ØD	ØK	n x Ød	Weight	ØD	ØK	n x Ød	Weight
				mm			kg	mm			kg
100	350	140	223	220	180	8x19	32	235	190	8x23	33
125	400	140	251	250	210	8x19	44	270	220	8x28	44
150	480	140	247	285	240	8x23	56	300	250	8x28	56
200	600	306	418	340	295	12x23	98	360	310	12x28	107
250	730	306	471	400	355	12x28	153	425	370	12x31	172
300	850	306	525	460	410	12x28	247	485	430	16x31	278
350	980	306	590	520	470	16x28	374	555	490	16x34	420
400	1100	306	684	580	525	16x31	525	620	550	16x37	603

Remark: "n" is number of holes in the flange.

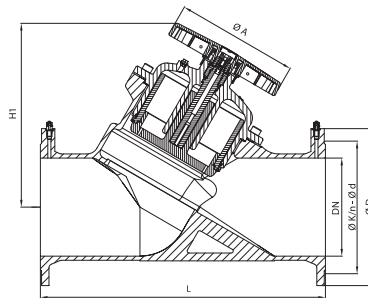

MSV-F2 DN 200-400

Installation

Always install the valve with the arrow on the body in the same direction as the flow. In order to avoid turbulence, which will affect the measuring accuracy, it is recommended to have a straight length of pipe up and down stream from the valve as shown (D - diameter of pipe).

The influence of turbulence, if our recommendations are not adhered to, can influence the flow up to 20%.

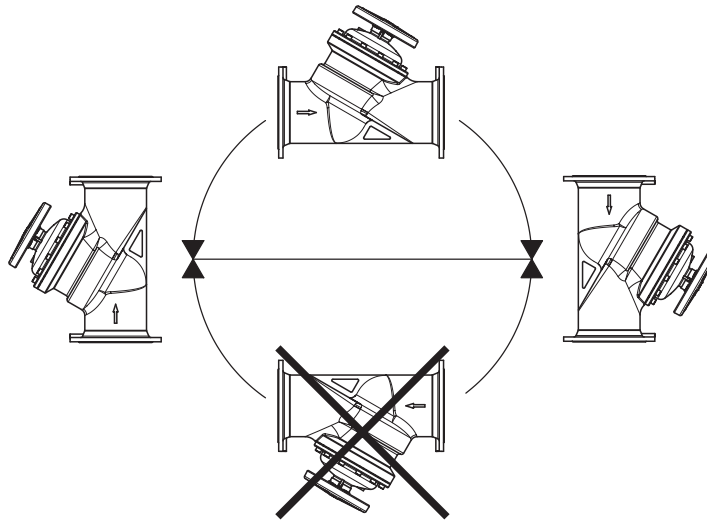
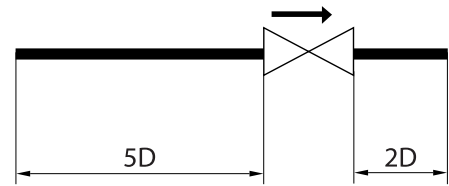

Certificates, declarations and approvals

The list contains all certificates, declarations, and approvals for this product type. Individual code number may have some or all of these approvals, and certain local approvals may not appear on the list.

When you click on the link you will be directed to the latest version of the 'Declaration of Conformity'. Products developed and sold before this date of issue conform to the directives/standards in force at the time of their sale.

Approval type	Title	Certification body	Approval topic
Pressure Safety Certificate	CE-0062-PED-H-DAF 002-24-DNK-rev-A	BV - Bureau Veritas	Pressure, PED
UA Declaration	Danfoss UA 2023-01-23 MTC ASV RA FH RAX PL03 PL28	Danfoss	Pressure, PED
Pressure Safety Certificate	LLC CDC EURO-TYSK UA.TR.089.1011.01-22	LLC CDC EURO TYSK - Ukraine	Pressure, PED
EU Declaration	EU declaration BF27112024-en01	Danfoss	Pressure, PED
Export Control Declaration	Butterfly, other valves, Manual balancing valves, one pipe solution valves and hot water balancing valves	Danfoss	

Contact details

Online support

Danfoss offers a wide range of support along with our products, including digital information, software, mobile apps and expert guidance. See the possibilities below.



The Danfoss Design center

Discover the Design Center, our advanced digital platform that streamlines product selection. With integrated tools and enhanced type pages, it's simpler than ever to access product information and documentation, and to select the right products. Check the availability of Danfoss products at partner locations and enjoy seamless transitions from selection to purchase with our basket-to-basket functionality. Whether you're buying from our distributors or directly from the Product Store, the Design Center simplifies your experience. Learn more at: designcenter.danfoss.com.



The Danfoss product store

The Danfoss Product Store is a one-stop shop available 24/7 for our customers, no matter where you are in the world or what area of industry you work in. Browse our catalog, check product details and documentation, view your prices and product availability, and quickly finalize your purchase. Start browsing at: store.danfoss.com.



Danfoss Partner Portal/Product Data tool

Designed to support you with easy access to product data extracts, essential resources, tools, and information. The Partner Portal provides a centralized hub for product documentation, training materials, marketing assets, and technical support, ensuring you have everything you need to succeed and grow your business with Danfoss. The Partner Portal is available 24/7 at: partner.danfoss.com and is ready to support your business.



Find technical documentation

Find technical documentation you need to get your project up running. Get direct access to our official collection of data sheets, certificates and declarations, manuals and guides, 3D models and drawings, case stories, brochures, and much more. Start searching now at: documentation.danfoss.com.



Danfoss Learning

Danfoss Learning is a free online learning platform. It features courses and materials specifically designed to help engineers, installers, service technicians, and wholesalers better understand the products, applications industry topics, and trends that will help you do your job better. Find your local Danfoss website here: learning.danfoss.com.



Get local information and support

Local Danfoss websites are the main sources for help and information about our company and products. Find product availability, get the latest regional news, or connect with a nearby expert - all in your own language. Find your local Danfoss website here: danfoss.com.

Danfoss A/S

Climate Solutions . danfoss.com . +45 7488 2222

Any information, including, but not limited to information on selection of product, its application or use, product design, weight, dimensions, capacity or any other technical data in product manuals, catalogues description, advertisements, etc. and whether made available in writing, orally, electronically, online or via download, shall be considered informative, and is only binding if and to the extent, explicit reference is made in a quotation or order confirmation. Danfoss cannot accept any responsibility for possible errors in catalogues, brochures, videos and other material. Danfoss reserves the right to alter its products without notice. This also applies to products ordered but not delivered provided that such alterations can be made without changes to form, fit or function of the products. All trademarks in this material are property of Danfoss A/S or Danfoss group companies. Danfoss and the Danfoss logo are trademarks of Danfoss A/S. All rights reserved.
