



Manual balancing

MSV-D Manual Presetting Valves LENO™

Description

LENO MSV-D is a new generation of manual valves for balancing flow in heating and cooling systems.

Dynamic balancing valves are the preferred option for hydronic balancing in constant and variable flow systems. If manual balancing valves are used for hydronic balancing they are better suited for constant flow systems. Manual balancing valves can be used in both constant and variable flow systems for flow verification, shut off function for service and repair. The valve may be mounted in flow or return.

Danfoss PFM 100/1000 are Danfoss recommended measuring devices.

Features & benefits

- Removable hand wheel for easy mounting
- Numeric presetting scale, visible from more angles
- Easy locking of presetting
- Built-in measuring nipples for 3 mm needles
- Open-close with Allen key in emergency
- Open-closed colour indicator

Applications

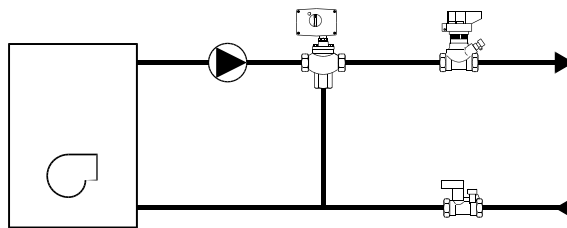

Boiler, flat station or heat pump in 1-family houses.

- For balancing.
- Shut-off function for service / repair.

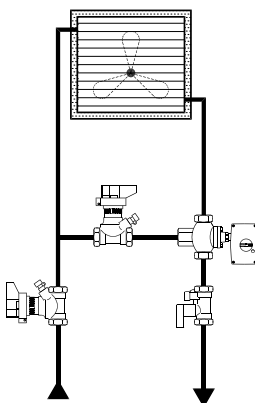

Air handling unit

- For constant flow.
- For balancing.
- Shut-off function for service / repair.

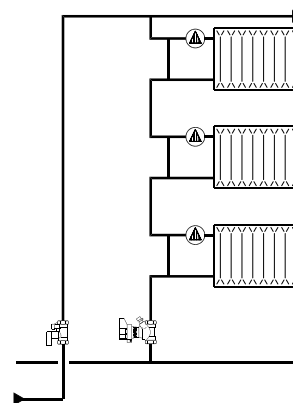

1-pipe system

- For balancing.
- Shut-off function for service / repair.

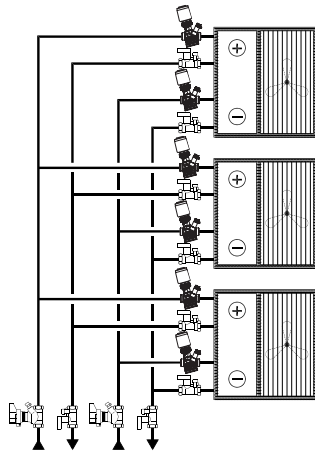

Fan coils











- For flow verification.
- Shut-off function for service / repair.

Ordering

Product code numbers

Description	Valve body material	Valve size	Kvs values [m ³ /h]	Connections	Code number
LENO™ MSV-D valve with internal thread DN 15 LF	CW 617N	DN 15 LF	2.50	G ½	003Z7000
LENO™ MSV-D valve with internal thread DN 15	CW 617N	DN 15	3.00	G ½	003Z7001
LENO™ MSV-D valve with internal thread DN 20	CW 617N	DN 20	6.00	G ¾	003Z7002
LENO™ MSV-D valve with internal thread DN 25	CW 617N	DN 25	9.50	G 1	003Z7003
LENO™ MSV-D valve with internal thread DN 32	CW 617N	DN 32	18.00	G 1 ¼"	003Z7004
LENO™ MSV-D valve with internal thread DN 40	CW 617N	DN 40	26.00	G 1 ½"	003Z7005
LENO™ MSV-D valve with internal thread DN 50	CW 617N	DN 50	40.00	G 2"	003Z7006

Accessories code numbers

 <p>003Z0233</p> <p>Tailpiece with External thread DN 20</p> <p>Tailpiece with External thread DN 20</p>	 <p>003Z0234</p> <p>Tailpiece with External thread DN 25</p> <p>Tailpiece with External thread DN 25</p>	 <p>003L8260</p> <p>PFM 100</p> <p>PFM 100, Measuring instrument is used for differential pressure measurements</p>	 <p>003Z0232</p> <p>Tailpiece with External thread DN 15</p> <p>Tailpiece with External thread DN 15</p>
 <p>003Z0235</p> <p>Tailpiece with External thread DN 32</p> <p>Tailpiece with External thread DN 32</p>	 <p>003Z8261</p> <p>PFM 1000, 20 bar</p> <p>PFM 1000, 20 bar, measuring instrument for balancing cooling, heating and domestic hot water systems.</p>	 <p>003Z8260</p> <p>PFM 1000, 10 bar</p> <p>PFM 1000, 10 bar, measuring instrument for balancing cooling, heating and domestic hot water systems.</p>	 <p>003Z4660</p> <p>Identification tag and strips (10 pcs.)</p> <p>Identification tag and strips (10 pcs.)</p>
 <p>003Z0274</p> <p>Tailpiece with thread DN 50 (2 1/4" nut)</p> <p>Tailpiece with thread DN 50 (2 1/4" nut)</p>	 <p>003Z4652</p> <p>Operating handle DN 15 - 50</p> <p>Operating handle DN 15 - 50</p>	 <p>003Z0273</p> <p>Tailpiece with thread DN 40 (1 3/4" nut)</p> <p>Tailpiece with thread DN 40 (1 3/4" nut)</p>	

Functions

Shut-Off

In order to shut-off the valve the handle must be pressed down.

The shut-off function features a ball valve, which only requires a 90 degree turn to shut the valve completely.

An indicator window shows the actual setting:

- red = closed
- white = open

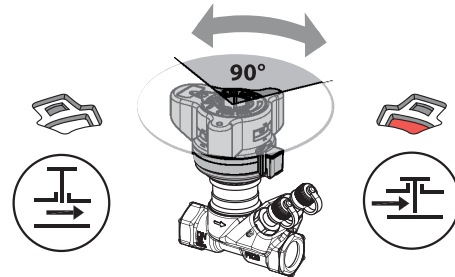

Bi-directional functionality

Due to the valve's design it can be installed in the system so that the medium flows through the valve in same direction as is marked on the valve body (Flow arrow), or it can be installed in the system in the opposite direction, so that medium flows through the valve in the opposite direction to the marking on the valve body. The valve kv values will remain unchanged, regardless of valve orientation.



Please, scan QR code or click on link to see animation:

<https://youtu.be/4zLTNO-jc4Y>

Operation

Flow Diagrammes, DN 15 LF LENO™ MSV-D DN 15 LF

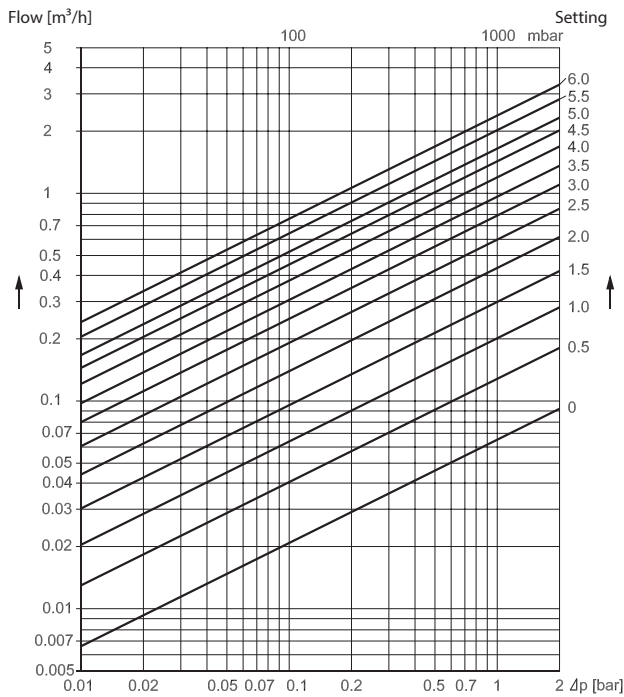

Flow characteristics

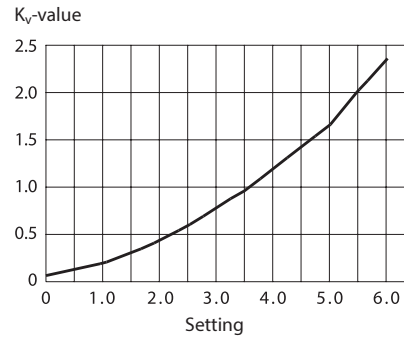

Setting	k _v -value	Setting	k _v -value	Setting	k _v -value
0.0	0.07	2.2	0.50	4.3	1.33
0.1	0.08	2.3	0.53	4.4	1.38
0.2	0.09	2.4	0.56	4.5	1.43
0.3	0.11	2.5	0.60	4.6	1.48
0.4	0.12	2.6	0.63	4.7	1.52
0.5	0.13	2.7	0.67	4.8	1.56
0.6	0.15	2.8	0.71	4.9	1.61
0.7	0.16	2.9	0.74	5.0	1.65
0.8	0.17	3.0	0.78	5.1	1.72
0.9	0.19	3.1	0.82	5.2	1.78
1.0	0.20	3.2	0.86	5.3	1.84
1.1	0.22	3.3	0.89	5.4	1.94
1.2	0.23	3.4	0.93	5.5	2.03
1.3	0.25	3.5	0.97	5.6	2.10
1.4	0.28	3.6	1.01	5.7	2.17
1.5	0.30	3.7	1.05	5.8	2.23
1.6	0.32	3.8	1.10	5.9	2.30
1.7	0.35	3.9	1.15	6.0	2.36
1.8	0.38	4.0	1.19	6.1	2.42
1.9	0.41	4.1	1.24	6.2	2.47
2.0	0.44	4.2	1.29	6.3	2.53
2.1	0.47				

Flow Diagrammes, DN 15
LENO™ MSV-D DN 15

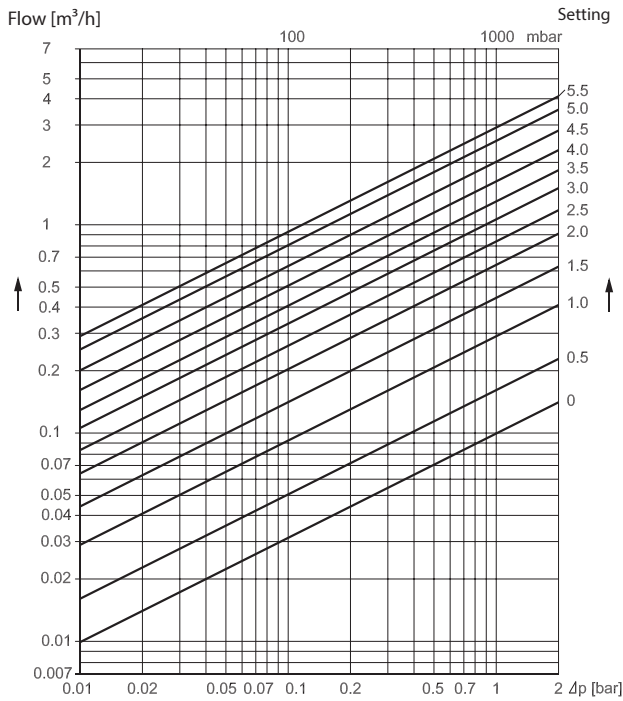

Flow characteristics

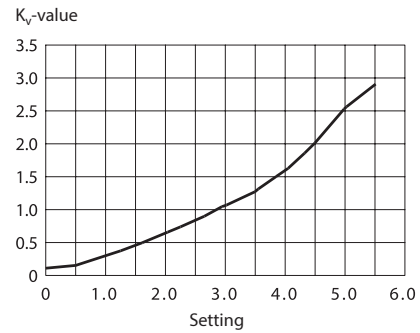

Setting	k_v -value	Setting	k_v -value	Setting	k_v -value
0.0	0.11	2.0	0.63	4.0	1.59
0.1	0.12	2.1	0.67	4.1	1.66
0.2	0.13	2.2	0.71	4.2	1.74
0.3	0.14	2.3	0.75	4.3	1.82
0.4	0.16	2.4	0.80	4.4	1.91
0.5	0.19	2.5	0.84	4.5	2.00
0.6	0.20	2.6	0.88	4.6	2.12
0.7	0.21	2.7	0.93	4.7	2.23
0.8	0.24	2.8	0.97	4.8	2.33
0.9	0.27	2.9	1.02	4.9	2.43
0.10	0.29	3.0	1.06	5.0	2.53
1.1	0.32	3.1	1.10	5.1	2.61
1.2	0.35	3.2	1.14	5.2	2.70
1.3	0.38	3.3	1.19	5.3	2.77
1.4	0.41	3.4	1.23	5.4	2.84
1.5	0.44	3.5	1.28	5.5	2.90
1.6	0.48	3.6	1.34	5.6	2.95
1.7	0.51	3.7	1.40	5.7	3.00
1.8	0.55	3.8	1.46		
1.9	0.59	3.9	1.52		

Flow Diagrammes, DN 20
LENO™ MSV-D DN 20

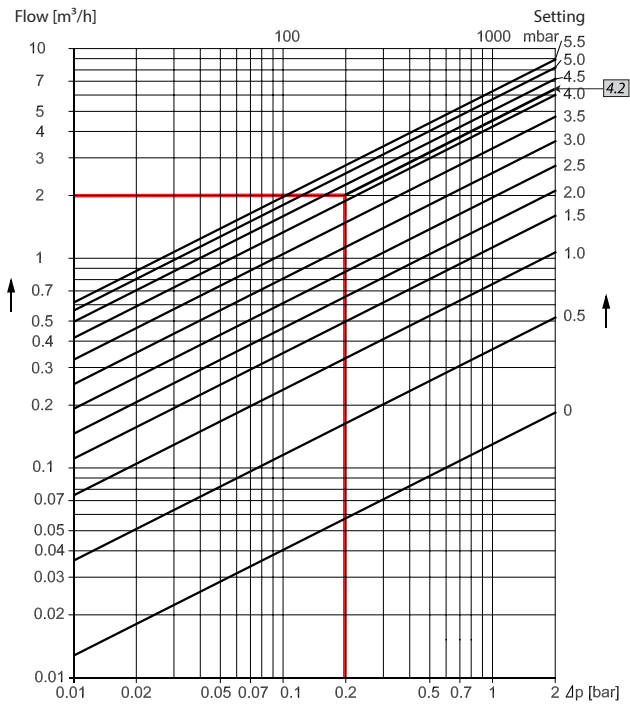

Flow characteristics

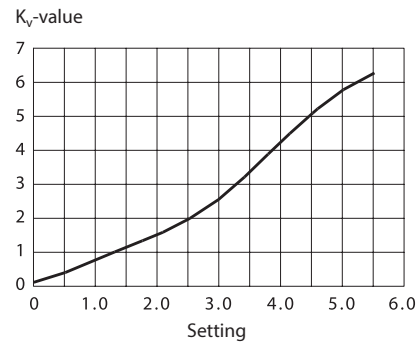

Setting	k_v -value	Setting	k_v -value	Setting	k_v -value
0.0	0.13	2.1	1.59	4.2	4.58
0.1	0.15	2.2	1.67	4.3	4.75
0.2	0.19	2.3	1.76	4.4	4.91
0.3	0.24	2.4	1.86	4.5	5.07
0.4	0.30	2.5	1.96	4.6	5.22
0.5	0.37	2.6	2.07	4.7	5.37
0.6	0.45	2.7	2.19	4.8	5.51
0.7	0.53	2.8	2.31	4.9	5.64
0.8	0.61	2.9	2.44	5.0	5.77
0.9	0.68	3.0	2.58	5.1	5.88
0.10	0.76	3.1	2.72	5.2	5.99
1.1	0.84	3.2	2.87	5.3	6.09
1.2	0.92	3.3	3.03	5.4	6.19
1.3	0.99	3.4	3.19	5.5	6.29
1.4	1.06	3.5	3.36	5.6	6.39
1.5	1.13	3.6	3.53	5.7	6.49
1.6	1.21	3.7	3.70	5.8	6.60
1.7	1.28	3.8	3.87		
1.8	1.35	3.9	4.05		
1.9	1.43	4.0	4.23		
2.0	1.50	4.1	4.40		

Flow Diagrammes, DN 25
LENO™ MSV-D DN 25

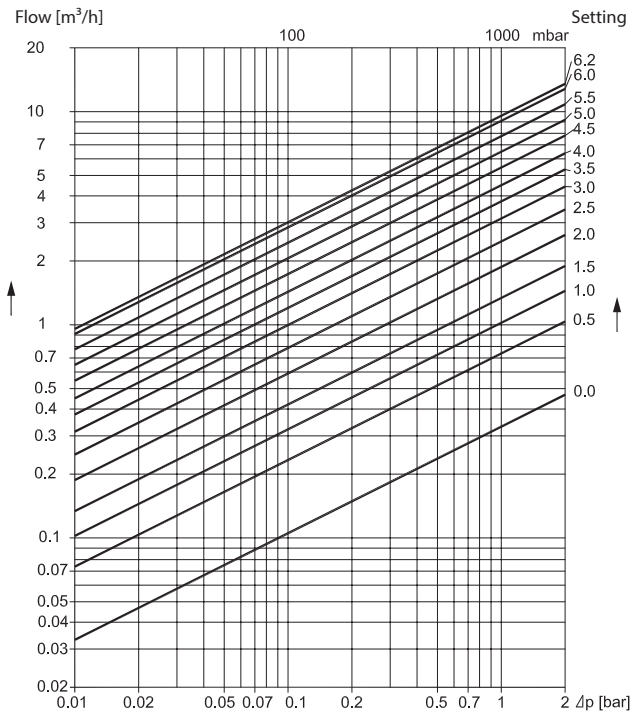

Flow characteristics

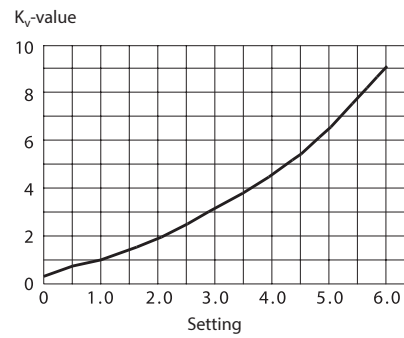

Setting	k_v -value	Setting	k_v -value	Setting	k_v -value
0.0	0.33	2.1	2.03	4.2	4.88
0.1	0.44	2.2	2.15	4.3	5.05
0.2	0.53	2.3	2.26	4.4	5.23
0.3	0.61	2.4	2.39	4.5	5.42
0.4	0.68	2.5	2.51	4.6	5.62
0.5	0.74	2.6	2.64	4.7	5.83
0.6	0.79	2.7	2.76	4.8	6.05
0.7	0.85	2.8	2.89	4.9	6.27
0.8	0.91	2.9	3.02	5.0	6.51
0.9	0.96	3.0	3.15	5.1	6.75
0.10	1.03	3.1	3.28	5.2	7.00
1.1	1.09	3.2	3.41	5.3	7.26
1.2	1.16	3.3	3.54	5.4	7.53
1.3	1.24	3.4	3.68	5.5	7.80
1.4	1.32	3.5	3.81	5.6	8.06
1.5	1.41	3.6	3.95	5.7	8.33
1.6	1.50	3.7	4.09	5.8	8.59
1.7	1.60	3.8	4.24	5.9	8.84
1.8	1.70	3.9	4.39	6.0	9.08
1.9	1.80	4.0	4.55	6.1	9.30
2.0	1.91	4.1	4.71	6.2	9.50

Flow Diagrammes, DN 32
LENO™ MSV-D DN 32

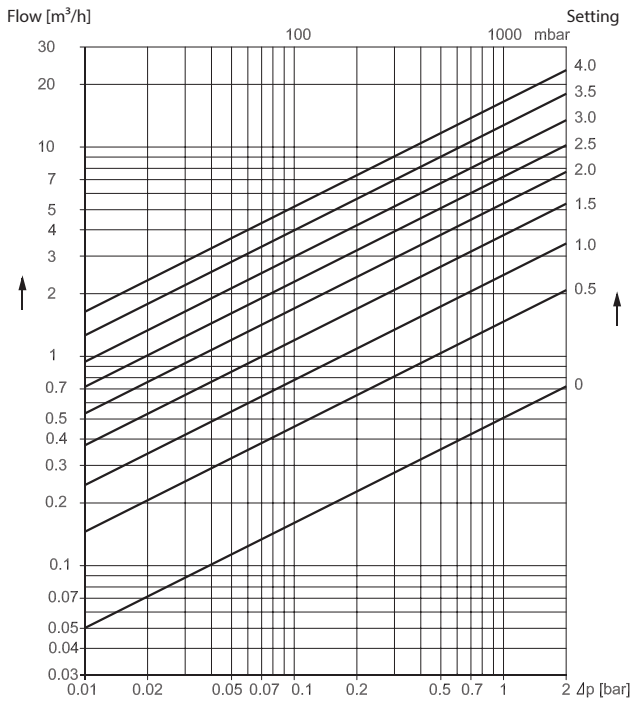

Flow characteristics

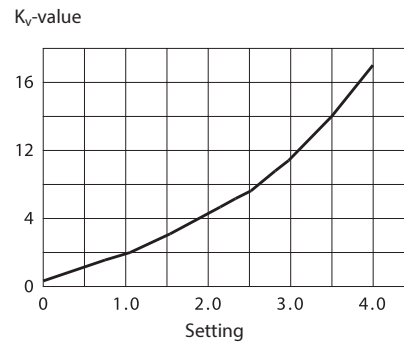

Setting	k_v -value	Setting	k_v -value	Setting	k_v -value
0.0	0.50	1.5	3.75	3.0	9.35
0.1	0.75	1.6	4.05	3.1	9.92
0.2	0.95	1.7	4.36	3.2	10.52
0.3	1.13	1.8	4.67	3.3	11.16
0.4	1.29	1.9	4.98	3.4	11.85
0.5	1.45	2.0	5.30	3.5	12.51
0.6	1.62	2.1	5.63	3.6	13.23
0.7	1.80	2.2	5.97	3.7	13.98
0.8	1.99	2.3	6.32	3.8	14.74
0.9	2.20	2.4	6.68	3.9	15.49
1.0	2.42	2.5	7.06	4.0	16.23
1.1	2.66	2.6	7.46	4.1	16.91
1.2	2.92	2.7	7.89	4.2	17.51
1.3	3.19	2.8	8.34	4.3	18.00
1.4	3.47	2.9	8.83		



Flow Diagrammes, DN 40
LENO™ MSV-D DN 40

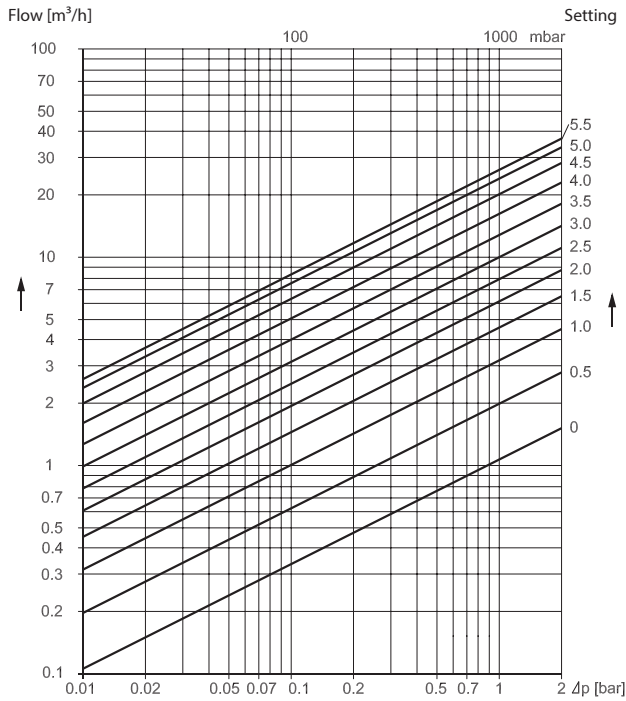

Flow characteristics

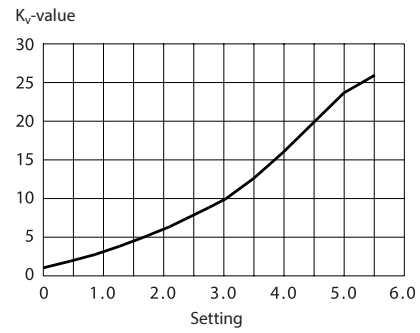

Setting	k_v -value	Setting	k_v -value	Setting	k_v -value
0.0	1.06	1.9	5.78	3.8	14.56
0.1	1.21	2.0	6.09	3.9	15.28
0.2	1.38	2.1	6.41	4.0	16.02
0.3	1.56	2.2	6.74	4.1	16.79
0.4	1.76	2.3	7.09	4.2	17.57
0.5	1.97	2.4	7.44	4.3	18.38
0.6	2.20	2.5	7.80	4.4	19.19
0.7	2.43	2.6	8.18	4.5	20.02
0.8	2.68	2.7	8.58	4.6	20.82
0.9	2.93	2.8	9.00	4.7	21.61
1.0	3.19	2.9	9.44	4.8	22.38
1.1	3.46	3.0	9.90	4.9	23.12
1.2	3.73	3.1	10.38	5.0	23.81
1.3	4.01	3.2	10.89	5.1	24.44
1.4	4.29	3.3	11.43	5.2	25.00
1.5	4.58	3.4	12.00	5.3	25.46
1.6	4.87	3.5	12.60	5.4	25.80
1.7	5.17	3.6	13.22	5.5	26.00
1.8	5.47	3.7	13.88		



Flow Diagrammes, DN 50
LENO™ MSV-D DN 50

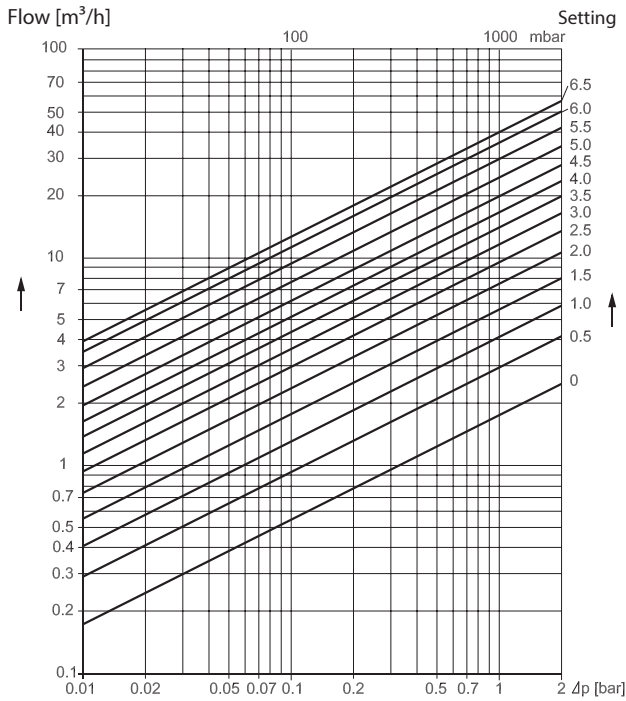

Flow characteristics

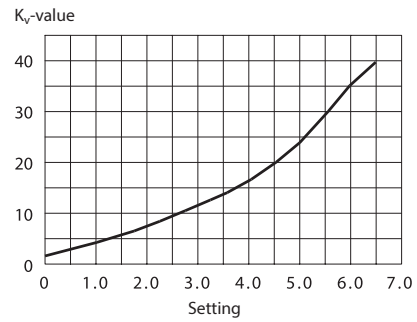

Setting	k _v -value	Setting	k _v -value	Setting	k _v -value
0.0	1.74	2.3	8.56	4.5	19.59
0.1	2.03	2.4	8.96	4.6	20.38
0.2	2.28	2.5	9.36	4.7	21.21
0.3	2.51	2.6	9.76	4.8	22.08
0.4	2.73	2.7	10.17	4.9	23.00
0.5	2.95	2.8	10.58	5.0	23.96
0.6	3.16	2.9	10.99	5.1	24.96
0.7	3.38	3.0	11.41	5.2	26.00
0.8	3.61	3.1	11.84	5.3	27.07
0.9	3.85	3.2	12.27	5.4	28.17
1.0	4.10	3.3	12.71	5.5	29.30
1.1	4.37	3.4	13.16	5.6	30.44
1.2	4.65	3.5	13.62	5.7	31.67
1.3	4.95	3.6	14.10	5.8	32.83
1.4	5.26	3.7	14.60	5.9	34.01
1.5	5.59	3.8	15.12	6.0	35.14
1.6	5.93	3.9	15.66	6.1	36.23
1.7	6.28	4.0	16.23	6.2	37.24
1.8	6.64	4.1	16.84	6.3	38.14
1.9	7.01	4.2	17.47	6.4	38.93
2.0	7.39	4.3	18.14	6.5	39.56
2.1	7.78	4.4	18.84	6.6	40.00
2.2	8.17				

Settings

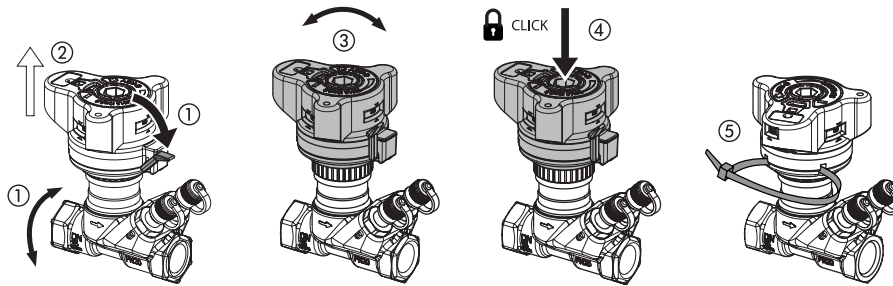

The valve has a built-in presetting feature for accurate flow ratings.

Setting the required flow is made in 5 steps:

1. In open position, release the lock using the green lever or a 3 mm Allen key.
2. The handle pops up automatically.
3. The calculated value can now be set.
4. The setting is locked when the handle is pressed to click.
5. Seal - the setting can be protected by using a strip as shown.

Presettings

Valve Size and Presetting

Example:

Given

Max. pipe flow $Q = 2.0 \text{ m}^3/\text{h}$

$\Delta p_r = 15 \text{ kPa}$

$\Delta p_a = 45 \text{ kPa}$

$\Delta p_m = 10 \text{ kPa}$

$\Delta p_i = \Delta p_a - \Delta p_r - \Delta p_m$

$\Delta p_i = 45 \text{ kPa} - 15 \text{ kPa} - 10 \text{ kPa} = 20 \text{ kPa}$

Correct valve size and presetting is found in flow diagramme.

$Q = 2.0 \text{ m}^3/\text{h}$ and $\Delta p_i = 20 \text{ kPa}$

Setting can be also calculated from the formula:

$$k_v = \frac{Q[\text{m}^3/\text{h}]}{\sqrt{p_i[\text{bar}]}} = \frac{2.0}{\sqrt{0.20}} = 4.5 \text{ m}^3/\text{h}$$

MSV-D

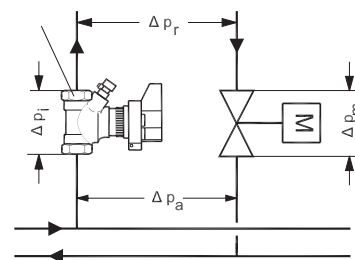

Δp_i Pressure drop across LENO™ MSV-D valve

Δp_m Pressure drop across valve

Δp_r Necessary pressure for the riser

Δp_a Available pressure for the riser

Product details

General data

Technical Data

Max. static working pressure	20 bar
Static test pressure	30 bar
Max. differential pressure across valve	2.5 bar (250 kPa)
Max. flow temperature	120 °C
Min. temperature	-20°C
Cooling liquids	Ethylene glycol / propylene glycol and HYCOOL (max. 30 %)

Measuring

The flow through the LENO™ MSV-D valve can be measured using Danfoss PFM 100/1000 or other brands of measuring instruments. The LENO™ MSV-D valve is supplied with two measuring test ports for 3 mm needles.

Procedure for flow measuring:

1. Select flow measuring
2. Select valve brand
3. Select valve type and dimension
4. Enter presetting
5. Connect valve and instrument
6. Calibrate static pressure
7. Measure the flow

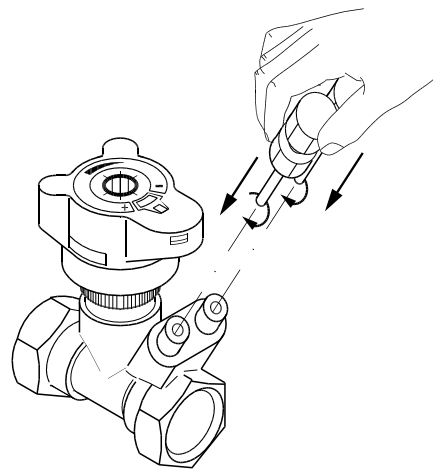

Measuring Accuracy

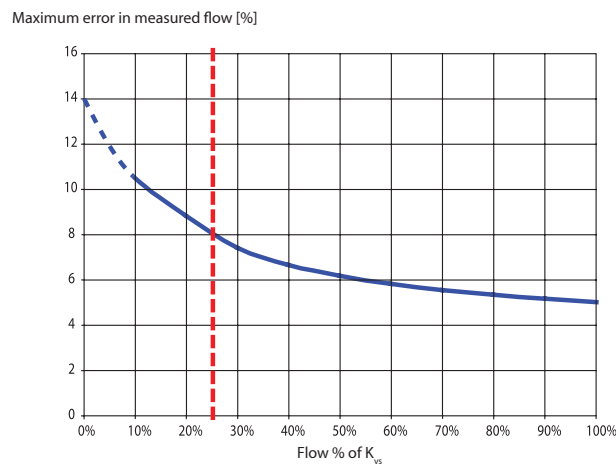

The red line indicates 25% of max. flow.
According to BS7350:1990 flow rates must be within following values:

- ± 18 % at 25 % open position
- ± 10 % at fully open position

LENO™ MSV-D is very accurate, due to the separate functions for presetting and shut-off.

K_v-Signal

K_v-signal values are used for non-Danfoss measuring instruments. Danfoss PFM1000 have all data in memory, and the instruments are using this formula:

$$P_{\text{val}} = P_{\text{sig}} \left(1 + 4 \cdot \frac{k_{\text{v-sig}}}{k_{\text{v-val}}} \right)^2$$

Δp across the measuring nipples (k_{v-sig}) and Δp across the valve (k_{v-val}) is not the same due to turbulence influence for pressure measuring.

K_v-Signal Values

Setting	DN 15LF	DN 15	DN 20	DN 25	DN 32	DN 40	DN 50
0.0	0.07	0.10	0.12	0.34	0.51	1.05	1.75
0.1	0.08	0.11	0.16	0.44	0.73	1.20	2.01
0.2	0.09	0.12	0.20	0.53	0.92	1.36	2.25
0.3	0.11	0.13	0.26	0.61	1.10	1.55	2.47
0.4	0.12	0.14	0.32	0.67	1.26	1.74	2.69
0.5	0.13	0.16	0.38	0.73	1.43	1.95	2.91
0.6	0.15	0.19	0.45	0.79	1.60	2.17	3.12
0.7	0.16	0.21	0.53	0.84	1.78	2.40	3.35
0.8	0.17	0.24	0.60	0.90	1.97	2.64	3.58
0.9	0.19	0.26	0.67	0.95	2.18	2.88	3.82
1.0	0.20	0.29	0.74	1.01	2.39	3.13	4.07
1.1	0.21	0.32	0.82	1.08	2.62	3.39	4.33
1.2	0.23	0.34	0.89	1.14	2.87	3.64	4.60
1.3	0.25	0.37	0.96	1.22	3.12	3.90	4.89
1.4	0.27	0.40	1.03	1.29	3.38	4.16	5.18
1.5	0.30	0.44	1.09	1.37	3.64	4.43	5.49
1.6	0.32	0.47	1.16	1.46	3.92	4.69	5.80
1.7	0.35	0.51	1.23	1.55	4.18	4.96	6.13
1.8	0.37	0.54	1.30	1.65	4.48	5.24	6.46
1.9	0.40	0.58	1.38	1.75	4.76	5.51	6.80
2.0	0.43	0.61	1.45	1.85	5.05	5.80	7.14
2.1	0.46	0.65	1.53	1.96	5.35	6.08	7.49
2.2	0.49	0.69	1.61	2.07	5.65	6.38	7.84
2.3	0.52	0.73	1.69	2.18	5.96	6.68	8.19
2.4	0.56	0.77	1.78	2.29	6.27	6.99	8.55
2.5	0.59	0.80	1.87	2.41	6.60	7.30	8.91
2.6	0.62	0.85	1.97	2.53	6.94	7.63	9.27
2.7	0.66	0.89	2.07	2.65	7.29	7.98	9.64
2.8	0.69	0.93	2.17	2.77	7.67	8.33	10.00
2.9	0.73	0.97	2.29	2.89	8.06	8.70	10.37
3.0	0.76	1.01	2.40	3.01	8.48	9.08	10.74
3.1	0.80	1.04	2.52	3.13	8.92	9.48	11.11
3.2	0.83	1.08	2.65	3.25	9.38	9.90	11.49
3.3	0.87	1.12	2.78	3.37	9.87	10.33	11.88
3.4	0.90	1.16	2.91	3.49	10.38	10.79	12.27
3.5	0.94	1.20	3.05	3.62	10.91	11.26	12.67
3.6	0.97	1.25	3.19	3.74	11.46	11.74	13.09
3.7	1.00	1.30	3.33	3.87	12.02	12.25	13.51
3.8	1.06	1.35	3.47	4.00	12.58	12.77	13.95

Setting	DN 15LF	DN 15	DN 20	DN 25	DN 32	DN 40	DN 50
3.9	1.10	1.41	3.61	4.13	13.12	13.30	14.41
4.0	1.14	1.47	3.75	4.26	13.64	13.85	14.88
4.1	1.18	1.53	3.89	4.39	14.12	14.41	15.38
4.2	1.23	1.59	4.02	4.53	14.52	14.98	15.89
4.3	1.27	1.66	4.15	4.68	14.84	15.55	16.44
4.4	1.31	1.73	4.28	4.82	-	16.13	17.00
4.5	1.35	1.81	4.40	4.98	-	16.69	17.59
4.6	1.39	1.91	4.52	5.13	-	17.25	18.21
4.7	1.43	2.00	4.62	5.29	-	17.80	18.86
4.8	1.47	2.08	4.72	5.46	-	18.32	19.54
4.9	1.51	2.16	4.82	5.64	-	18.80	20.24
5.0	1.54	2.23	4.90	5.81	-	19.25	20.97
5.1	1.60	2.30	4.97	6.00	-	19.65	21.73
5.2	1.66	2.36	5.04	6.19	-	19.98	22.51
5.3	1.72	2.41	5.09	6.38	-	20.24	23.30
5.4	1.79	2.46	5.14	6.57	-	20.41	24.12
5.5	1.87	2.50	5.18	6.77	-	20.48	24.94
5.6	1.93	2.54	5.21	6.96	-	-	25.76
5.7	1.99	2.57	5.24	7.15	-	-	26.58
5.8	2.04	-	5.27	7.34	-	-	27.38
5.9	2.09	-	-	7.52	-	-	28.16
6.0	2.14	-	-	7.69	-	-	28.90
6.1	2.18	-	-	7.85	-	-	29.59
6.2	2.22	-	-	7.98	-	-	30.21
6.3	2.26	-	-	8.09	-	-	30.74
6.4	-	-	-	8.17	-	-	31.17
6.5	-	-	-	8.22	-	-	31.47
6.6	-	-	-	-	-	-	31.61

K_v-Signal

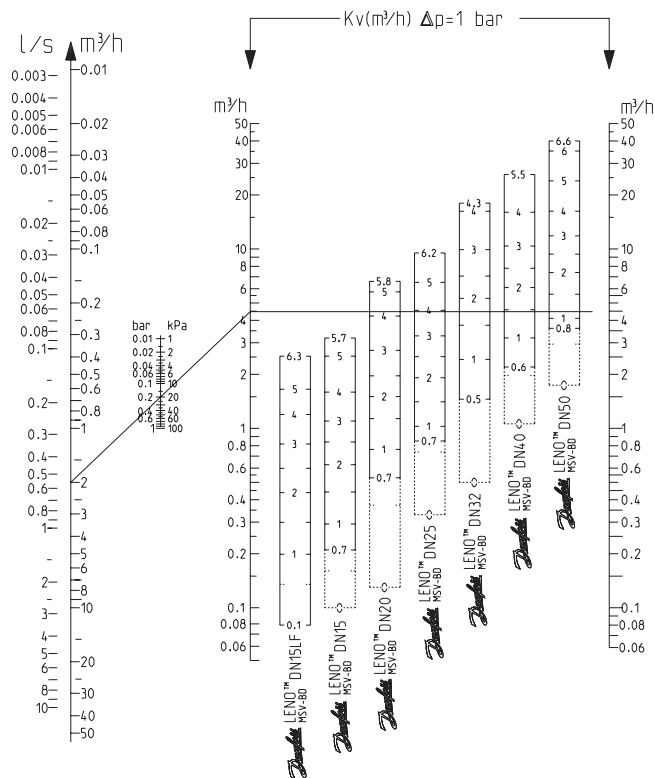

Design

1. Valve body
2. Ball
3. Ball seat
4. Support screw
5. Throttle bush
6. Spindle head
7. Spindle
8. Shut off bush
9. Spring
10. Rotation lock
11. Top
12. Measuring nipple
13. Handle
14. Gasket for support screw

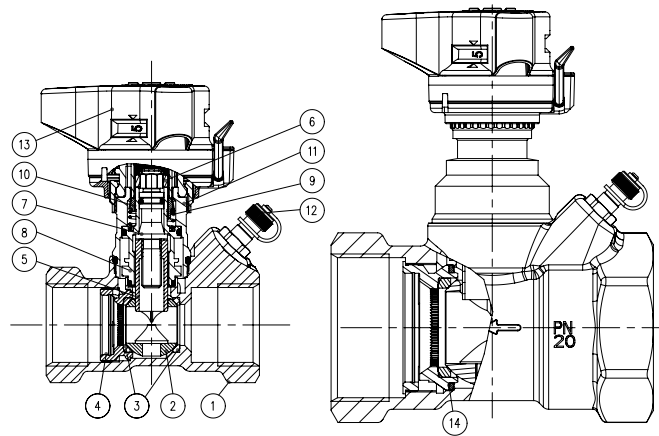

Materials

Materials and parts in contact with water

Valve body	Brass - CW617N
O-rings	EPDM
Ball	Brass/chromium plated
Ball sealing	Teflon

Pressure and temperature data

Correction Factors

Temp. °C	Correction factors, ethylene glycol / propylene glycol percentage (max. 30 %)						
	25	30	40	50	60	65	100
-40.0	¹⁾	¹⁾	¹⁾	¹⁾	0.89	0.88	¹⁾
-17.8	¹⁾	¹⁾	0.93	0.91	0.90	0.89	0.86
4.4	0.95	0.95	0.93	0.92	0.91	0.90	0.87
26.6	0.96	0.95	0.94	0.93	0.92	0.91	0.88
48.9	0.97	0.96	0.95	0.94	0.93	0.92	0.90
71.1	0.98	0.98	0.96	0.95	0.94	0.94	0.95
93.3	1.00	0.99	0.97	0.96	0.95	0.95	0.92
115.6	²⁾	²⁾	²⁾	²⁾	²⁾	²⁾	0.94

¹⁾ Below freezing point

²⁾ Above boiling point

Example:

Flow needed = 30 m³/h

Flow after correction:

30 x 0.95 = 28 m³/h

Dimensions

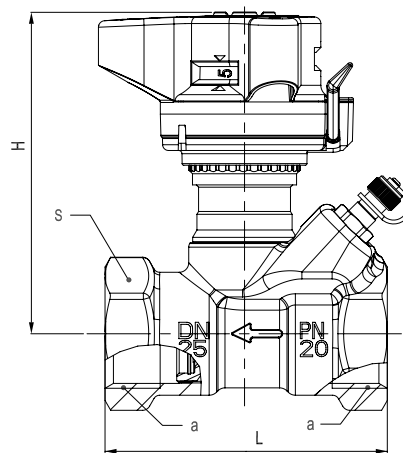

Size (DN)	Connections a (ISO 228/2)	L (mm)	H (mm)	S (mm)
15	G ½	76	92	27
20	G ¾	80	95	32
25	G 1	86	98	41
32	G 1 ¼	102	121	50
40	G 1 ½	102	125	55
50	G 2	130	129	67

Installation

Fitting

Before fitting the valve the installer must ensure that the pipe system is clean and:

1. the valve can be turned 360 degrees (if threaded pipe is used).
2. the valve is fitted according to the flow direction arrow.

Removal of the handle

1. Set the handle at 0/0.
2. Release the setting lock (green).
3. Unscrew the union nut.

Calibration of the handle

Before refitting, ensure that the handle setting is 0/0.

Bi-directional functionality

If necessary (due to space constraints or any other reason), the MSV-D valve can be installed in the reversed orientation. The design of the valve means that kv of the valve remains the same in both orientation. For additional explanation of bi-directional functionality please use the link below or scan the QR code on the box label.

DN	R1/R2 (mm)
15	92/57
20	95/60
25	98/63
32	121/86
40	125/90
50	129/94

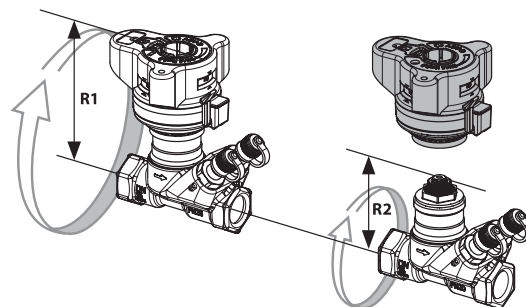

Certificates, declarations and approvals

The list contains all certificates, declarations, and approvals for this product type. Individual code number may have some or all of these approvals, and certain local approvals may not appear on the list.

When you click on the link you will be directed to the latest version of the 'Declaration of Conformity'. Products developed and sold before this date of issue conform to the directives/standards in force at the time of their sale.

Approval type	Title	Certification body	Approval topic
Manufacturer's Declaration	Danfoss MD BF26012023-en01	Danfoss	EU RoHS, PED, Pressure
UA Declaration	Danfoss UA 2023-01-23 MTC ASV RA FH RAX PL03 PL28	Danfoss	PED, Pressure
Export Control Declaration	Butterfly, other valves, Manual balancing valves, one pipe solution valves and hot water balancing valves	Danfoss	

Tender text

Features	LENO™ MSV-D
Balancing/Commissioning	•
Presetting	•
Fixed orifice	
Self sealing measuring nipples	•
Digital visible scale from more sides	•
Shut off function (ball valve)	•
Draining/filling	
Draining/filling on both sides of the valve	
Removable handle	•
Closing indicator	•
Allen key for ball valve	•
Parallel measuring nipples	•
360° rotating measuring station (drain cock and measuring nipples)	

Presetting values are visible on top of the valve and from all sides.

Presetting is locked by pressing down the handle. When locked, the shut off function can be used without changing the presetting.

The handle is released with the green key or with a 3 mm Allen key.

To prevent unintended changes of the presetting, the handle can be sealed by using a strip.

The valve is bi-directional.

LENO™ MSV-D has a leakage rate A according to BS 7350 : 1990, the ball valve is 100% tight.

There are no requirements for inlet and outlet conditions.

The LENO™ MSV-D measuring accuracy is 10% up to 25% of max. setting.

Accuracy is according to BS 7350 : 1990.

Measuring instruments must be equipped with 3mm measuring needles. Danfoss recommends using Danfoss PFM100 or Danfoss PFM1000.

Specifications	Details
Valve sizes	DN 15 (LF) – DN 50
Pressure class	PN20
Static test pressure	30 bar
Working temperature	-20°C to 120°C
Working area	10-100% of the k_{vs} -value

The valve body is made of CW617N brass.

The ball is made of chromium plated brass.

O-rings are made of EPDM rubber.

Contact details

Online support

Danfoss offers a wide range of support along with our products, including digital information, software, mobile apps and expert guidance. See the possibilities below.



The Danfoss Design center

Discover the Design Center, our advanced digital platform that streamlines product selection. With integrated tools and enhanced type pages, it's simpler than ever to access product information and documentation, and to select the right products. Check the availability of Danfoss products at partner locations and enjoy seamless transitions from selection to purchase with our basket-to-basket functionality. Whether you're buying from our distributors or directly from the Product Store, the Design Center simplifies your experience. Learn more at: designcenter.danfoss.com.



The Danfoss product store

The Danfoss Product Store is a one-stop shop available 24/7 for our customers, no matter where you are in the world or what area of industry you work in. Browse our catalog, check product details and documentation, view your prices and product availability, and quickly finalize your purchase. Start browsing at: store.danfoss.com.



Danfoss Partner Portal/Product Data tool

Designed to support you with easy access to product data extracts, essential resources, tools, and information. The Partner Portal provides a centralized hub for product documentation, training materials, marketing assets, and technical support, ensuring you have everything you need to succeed and grow your business with Danfoss. The Partner Portal is available 24/7 at: partner.danfoss.com and is ready to support your business.



Find technical documentation

Find technical documentation you need to get your project up running. Get direct access to our official collection of data sheets, certificates and declarations, manuals and guides, 3D models and drawings, case stories, brochures, and much more. Start searching now at: documentation.danfoss.com.



Danfoss Learning

Danfoss Learning is a free online learning platform. It features courses and materials specifically designed to help engineers, installers, service technicians, and wholesalers better understand the products, applications industry topics, and trends that will help you do your job better. Find your local Danfoss website here: learning.danfoss.com.



Get local information and support

Local Danfoss websites are the main sources for help and information about our company and products. Find product availability, get the latest regional news, or connect with a nearby expert - all in your own language. Find your local Danfoss website here: danfoss.com.

Danfoss A/S

Climate Solutions . danfoss.com . +45 7488 2222

Any information, including, but not limited to information on selection of product, its application or use, product design, weight, dimensions, capacity or any other technical data in product manuals, catalogues description, advertisements, etc. and whether made available in writing, orally, electronically, online or via download, shall be considered informative, and is only binding if and to the extent, explicit reference is made in a quotation or order confirmation. Danfoss cannot accept any responsibility for possible errors in catalogues, brochures, videos and other material. Danfoss reserves the right to alter its products without notice. This also applies to products ordered but not delivered provided that such alterations can be made without changes to form, fit or function of the products. All trademarks in this material are property of Danfoss A/S or Danfoss group companies. Danfoss and the Danfoss logo are trademarks of Danfoss A/S. All rights reserved.
