

AM-PBU 25 is a standby mains power backup unit for AME 85 or AME 55 actuators. It is used as an “Electronic Spring Return” unit. During a power failure an actuator can be powered to its open or closed position. Normal control of the actuator automatically resumes when power returns. The charger section of the AM-PBU 25 keeps the battery in peak condition at all times. The battery can be monitored remotely from a building management system (BMS) or volt meter.

The AM-PBU 25 can serve one AME 85 actuator or two AME 55 actuators.

**Ordering & Technical Data:**

AM-PBU 25	Code No.: <b>082H7090</b>
Power requirement	24 Vac / 40 VA
Power output	24 Vac / 25 VA, 2 spdt contacts
Output cycle time	6.5 minutes
Battery	12 V, 1.2 Ah
Ambient temperature	14...122°F (-10...50 °C)
Ambient humidity max.	65 % RH
Enclosure rating	NEMA 1 (IP 00)
Standards	Emission EN 50081-1 Immunity - EN 50082-1 Heat - IEC 68-2-2
Weight	0.67lb (0.3 kg)
Dimensions	7.5x5.0x1.9in (190 x 127 x 50mm) - panel mounted

**Operation:**

During normal operation 24 VAC power passes through normally open relay contacts in the AM-PBU 25 to the power input terminals on the actuators. In the event of a power failure the AM-PBU 25 starts to provide 24Vac power to the actuator from the frequency converter.

This drives the valve either open or closed depending on the wiring of the actuator. The power backup cycle lasts for 6.5 minutes. Normal operation is resumed when power is restored.

The condition of the battery can be monitored with terminals TG and BT connected to a volt meter or Building Management System (BMS).

Electrical Wiring:

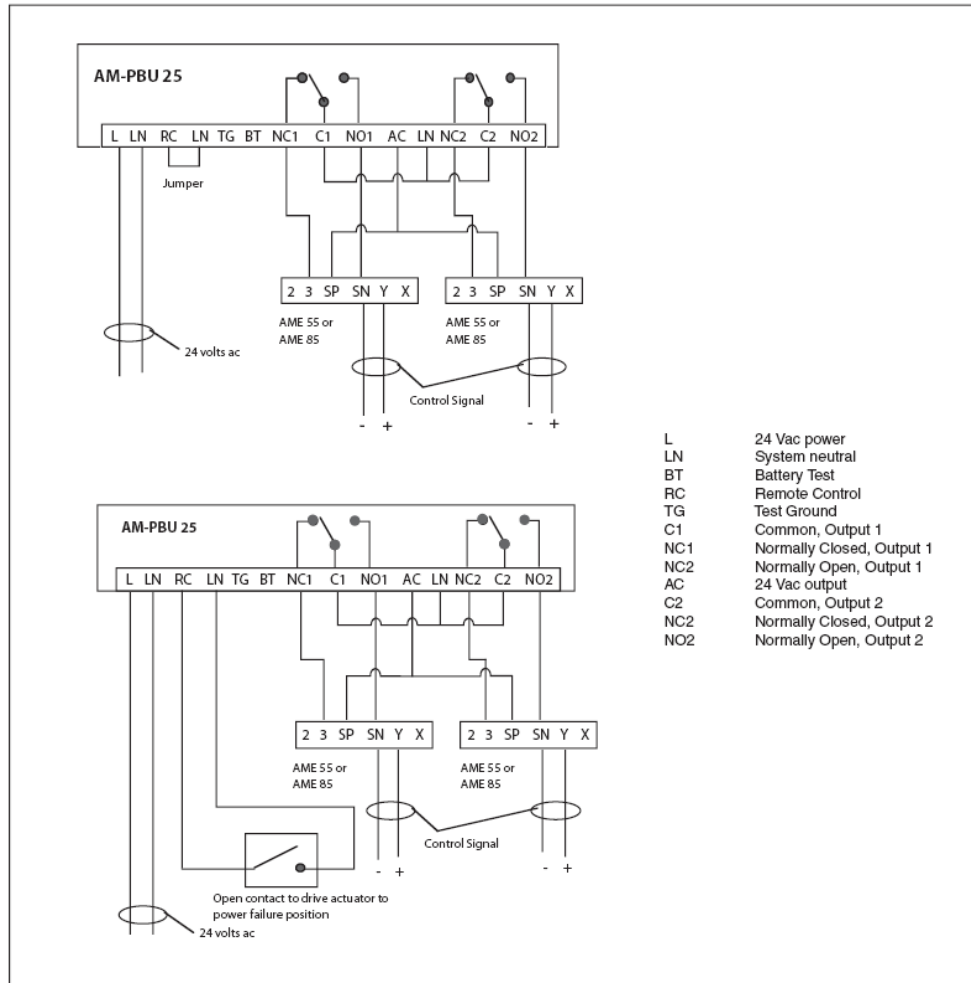

The jumper between LN & RC can be replaced by a connection to a building management system (BMS), a controller, or a manual switch. When the contact opens, the building mains power is disconnected and the AM-PBU 25 goes through a cycle, running on battery power. This feature can be used for remote control of the valve or for testing the battery. Connecting terminals TG and BT to a BMS or volt meter and taking a reading during an exercise cycle, gives a good indication of battery condition. Connecting NC1 or NC2 to terminal 3 on the actuator drives the valve stem down on power failure; connecting NC1 or NC2 to terminal 2 drives the valve stem up on power failure.

Danfoss can accept no responsibility for possible errors in printed materials and reserves the right to alter its products without notice. All trademarks in this material are property of the respective companies. Danfoss and Danfoss logotype are trademarks of Danfoss A/S. All right reserved.



Head Office:  
Danfoss Inc.  
Mississauga, ON CANADA  
Tel: 866-375-4822 Fax: 905.285.2055

USA Office:  
Danfoss Inc.  
Baltimore, MD USA  
Tel: 866-375-4822 Fax: 443.512.0270

[www.na.heating.danfoss.com](http://www.na.heating.danfoss.com)