

Fig. 1

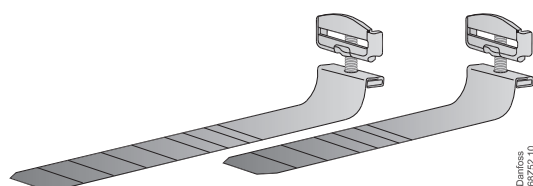

Fig. 2

Description	Qty	Min. delivery qty (industrial pack)	Code no.
Filter, fig. 1			
Pos. 11 Filter	1		068-0080
11 Filter		25	068-0003
12 Filter	1		068-0081
for flare-solder adaptor only			
12 Filter		20	068-0015
for flare-solder adaptor only			
Reducer flare nut, fig. 1			
Pos. 1 3/8 in. -1/4 in. / 6 mm		10	011L1107
Flare nut, fig. 1			
Pos. 1 3/8 in. or 10 mm		10	011L1135
3 1/4 in. or 6 mm		10	011L1101
Flare-solder adaptor, fig. 1			
Pos. 4 1/4 in.	1		068-2062
4 3/8 in.	1		068-2060
4 6 mm	1		068-2063
4 10 mm	1		068-2061
Flare-solder adaptor, fig. 1			
Pos. 4 1/4 in.		24	068-2082
4 3/8 in.		24	068-2080
4 6 mm		24	068-2083
4 10 mm		24	068-2081

Accessories		Pack mode	Code no.
Bulb strap, fig. 2			
0.4 mm, max. 28 mm tube	45		068U3505
0.4 mm, max. 50 mm tube	45		068U3506
0.4 mm, max. 28 mm tube	25		068U3507
0.4 mm, max. 50 mm tube	45		068U3508

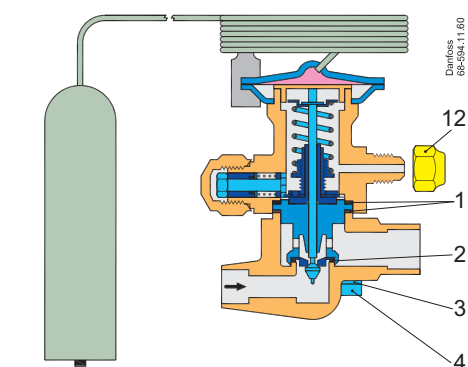

Fig. 1

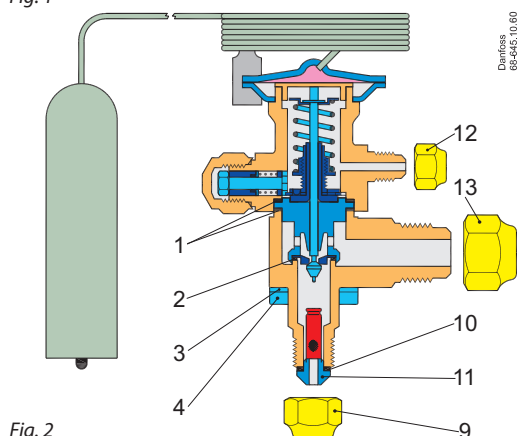

Fig. 2

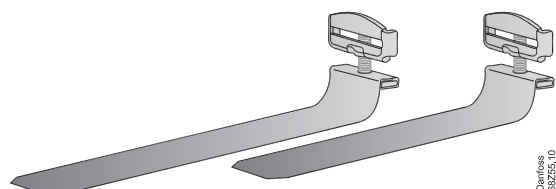

Fig. 3

Description	Qty	Min. delivery qty (industrial pack)	Code no.
Seal kit, figs. 1 and 2			068B0675
Pos. 1 Gasket	1		
2 O-ring	1		
Filter assembly, fig. 2			068B0171
Pos. 10 Gasket		5	
11 Filter		5	
Reducer flare nut, fig. 2			011L1142
Pos. 9 1/2 in. - 3/8 in. / 10 mm		10	
Flare nut, fig. 2			
Pos. 9 1/2 in. or 12 mm		10	011L1103
12 1/4 in. or 6 mm		10	011L1101
13 5/8 in., 15 or 16 mm		10	011L1167
Screws and washers, fig. 2			068B0018
Pos. 3 Stainless steel washer	4		
4 Stainless steel screw	4		

Accessories		Pack mode	Code no.
Bulb strap, fig. 3			
Length 140 mm, max. tube diameter 1 1/8	40	I	067N0551
Length 140 mm, max. tube diameter 1 1/8	40	M	067N0554
Length 225 mm, max. tube diameter 2 1/8	40	I	067N0557
Length 225 mm, max. tube diameter 2 1/8	40	M	067N0558
Length 350 mm, max. tube diameter 3 1/8	40	M	067N0559

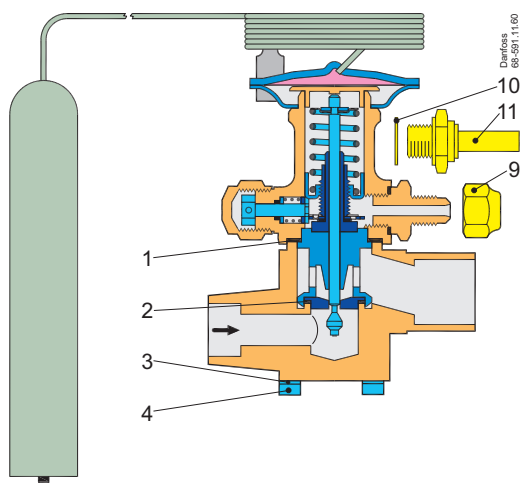

Fig. 1

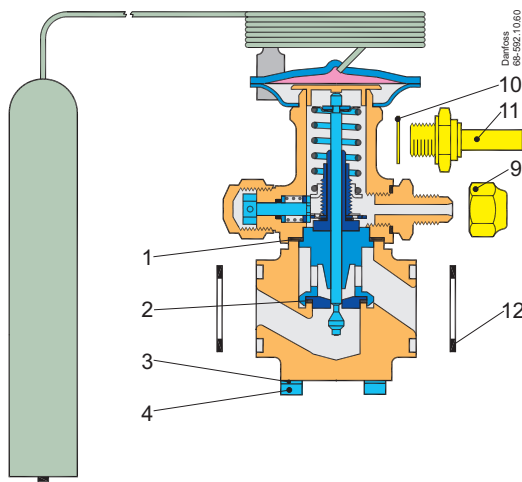

Fig. 2

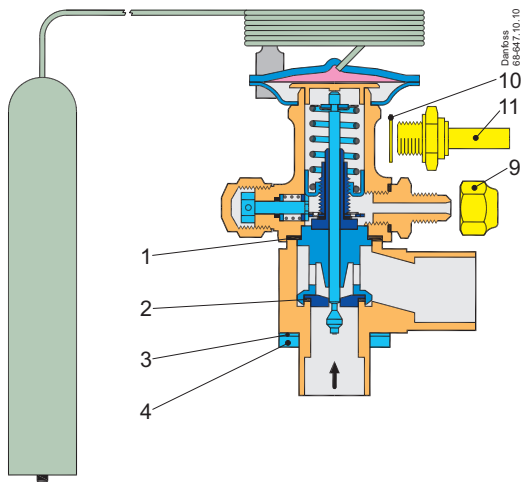

Fig. 3

Description	Qty	Min. delivery qty (industrial pack)	Code no.
Seal kit, figs. 1, 2 and 3			068B0676
Pos. 1 Gasket	1		
2 O-ring	1		
Flange gasket, fig. 2			020-2133
Pos. 12 for TE 12	2		
Flare nut, figs. 1, 2 and 3			011L1101
Pos. 9 1/4 in. or 6 mm		10	
Solder connector, figs. 1, 2 and 3 for 1/4 in. ext. equalization line			068B0170
Pos. 10 Gasket	1		
11 Connector	1		
Screws and washers, figs. 1, 2 and 3 for straightway and flange bodies			068B0017
Pos. 3 Stainless steel washer	4		
4 Stainless steel screw	4		
Screws and washers, fig. 3 for angleway bodies			068B0018
Pos. 3 Stainless steel washer	4		
4 Stainless steel screw	4		

Accessories	Pack mode	Code no.
Bulb strap, fig. 4		
Length 140 mm, max. tube diameter 1 1/8	I	067N0551
Length 140 mm, max. tube diameter 1 1/8	M	067N0554
Length 225 mm, max. tube diameter 2 1/8	I	067N0557
Length 225 mm, max. tube diameter 2 1/8	M	067N0558
Length 350 mm, max. tube diameter 3 1/8	M	067N0559

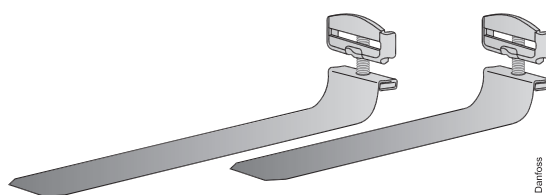
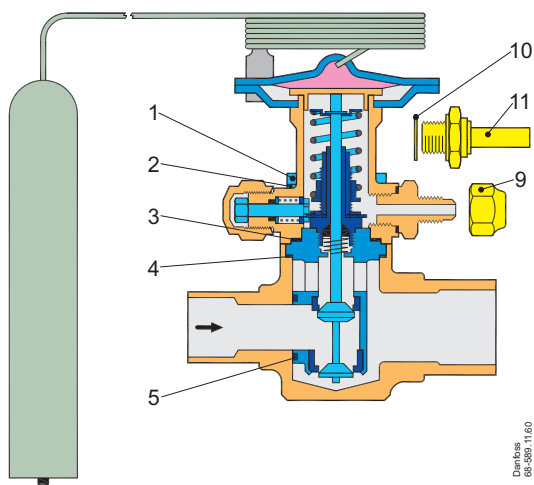
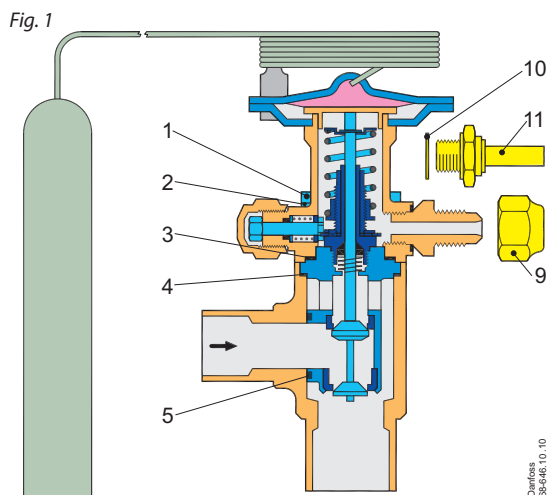

Fig. 4



Danfoss
68-889, 11.60

Description	Qty	Min. delivery qty (industrial pack)	Code no.
Seal kit, figs. 1 and 2			068G0050
Pos. 3 Gasket	1		
4 Gasket	1		
5 O-ring	1		
Flare nut, figs. 1 and 2			011L1101
Pos. 9 1/4 in. or 6 mm		10	
Solder connector, figs. 1 and 2 or 1/4 in. external equalization line			068B0170
Pos. 10 Gasket	1		
11 Connector	1		
Screws and washers, fig. 2			068B0020
Pos. 1 Screw	4		
2 Washer	4		
Screws and washers, fig. 2			068B0514
Pos. 1 Stainless steel screw	4		
2 Stainless steel washer	4		



Danfoss
68-889, 10-10

Accessories		Pack mode	Code no.
Bulb strap, fig. 3			
Length 140 mm, max. tube diameter 1 1/8	40	I	067N0551
Length 140 mm, max. tube diameter 1 1/8	40	M	067N0554
Length 225 mm, max. tube diameter 2 1/8	40	I	067N0557
Length 225 mm, max. tube diameter 2 1/8	40	M	067N0558
Length 350 mm, max. tube diameter 3 1/8	40	M	067N0559

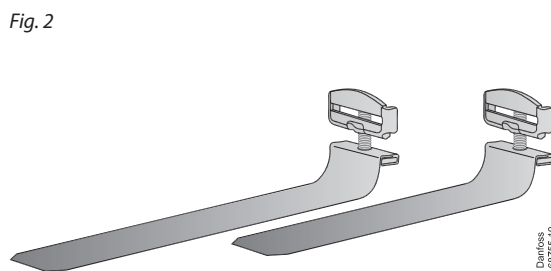

Danfoss
68-889, 10



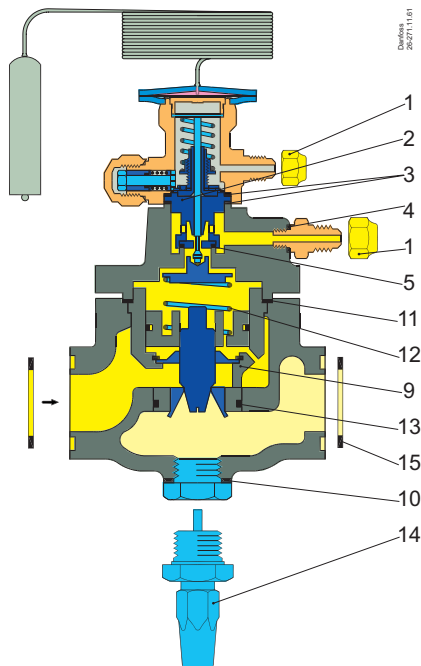

Fig. 1



Fig. 2

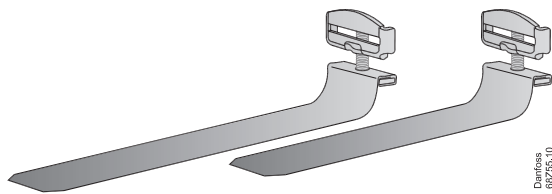

Fig. 3

		PHT 85	PHT 125	PHT 300
Description	Qty	Code no.	Code no.	Code no.
Insert assembly, fig. 1				
no. 1		026H1101	026H2183	026H2184
no. 2		026H1102		
no. 3		026H1103		
no. 4		026H1104		
no. 5		026H1105		
Pos. 9 Insert	1			
11 Gasket	1			
13 O-ring	1			
Seal kit, fig. 1				
Pos. 3 Gasket	2	026H0052	026H0053	026H0054
4 Gasket	1			
5 O-ring	1			
10 Gasket	1			
11 Gasket	1			
13 O-ring	1			
15 Flange gasket	2			
Main spring assembly, fig. 1				
no. 4, with P band 0.9 bar		026H0564		
no. 5, with P band 1.1 bar		026H0565		
Pos. 11 Gasket				
12 Main spring				
	1			
	1			
Pilot orifice, figs. 1 and 2				
for PHT 85, 125, 200 and 300		067B2790	067B2790	067B2790
Pos. 2 Orifice	1			
3 Gasket	2			
5 O-ring	1			
16 Adjustment key (fig. 2)	1			
Man. opening spindle, fig. 1				
for PHT 85 and PHT 125		026H0222	026H0222	(only 30% capacity)
Pos. 10 Gasket	1			
14 Man. opening spindle	1			
Flare nut, fig. 1				
Pos. 1 ¼ in. or 6 mm	10	011L1101	011L1101	011L1101

Accessories	Qty	Pack mode	Code no.
Bulb strap, fig. 3			
Length 140 mm, max. tube diameter 1 ¹ / ₈	40	I	067N0551
Length 140 mm, max. tube diameter 1 ¹ / ₈	40	M	067N0554
Length 225 mm, max. tube diameter 2 ¹ / ₈	40	I	067N0557
Length 225 mm, max. tube diameter 2 ¹ / ₈	40	M	067N0558
Length 350 mm, max. tube diameter 3 ¹ / ₈	40	M	067N0559