

Data Sheet

# VHS Valve with Integrated Pre-Setting and Shut-off/Drain

Application

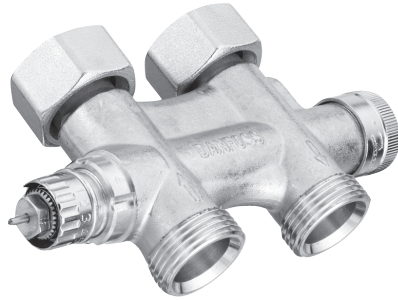

VHS straight

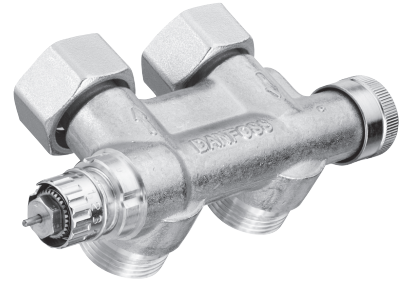

VHS angle

The VHS is the ideal control valve for modern base-connection radiators, as well as for universal or bathroom radiators with connection distances of 50mm between flow and return. Quick and easy to install, it will accept standard Danfoss snap-lock sensor elements.

The VHS incorporates an integral presetting mechanism, for quick and accurate system balancing, and a combined shut-off/drain device. Connection to copper, soft steel, alupex and PEX plastic pipes can be carried out with Danfoss clamping joints. An optional fill-and-drain fitting is available.

To avoid the occurrence of scale and corrosion in the system, the composition of the heating water should comply with VDI guidelines 2035.

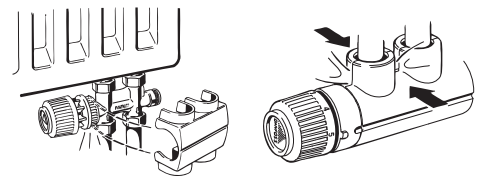

1. Cover

2. Enclosure for towel driers

To ensure an appealing finish different types of valve covers are available:

1. In white ABS material (RAL 9010) which is suitable for wet lacquering or in black PPO suitable for electrostatic powder lacquering.
2. Enclosure designed for towel dryers with angled valves.

System layout

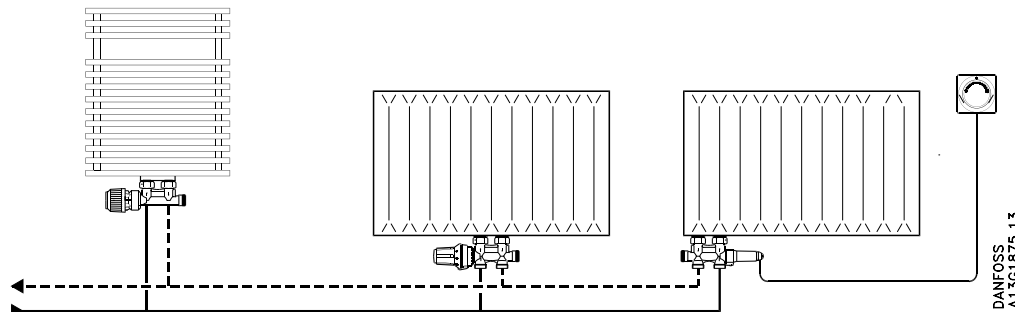

DANFOSS  
A1361875-13

# Datasheet

# VHS Valve with Integrated Pre-Setting and Shut-Off/Drain

## Ordering and data

VHS-UN 15	Connection		Settings									Code no.
	(ISO 228-1)		k <sub>v</sub> -values <sup>1) 2)</sup>									
	Radiator	System	1	2	3	4	5	6	7	N	N	
Angle	R½	G¾A	0.02	0.04	0.07	0.12	0.19	0.27	0.33	0.48	0.57	013G4741
Straight												013G4742
Angle	G¾											013G4743
Straight												013G4744

1) The k<sub>v</sub>-values represent the flow volume (Q) in m<sup>3</sup>/h at a pressure drop (Δp) through the valve of 1 bar;

$$k_v = \frac{Q}{\sqrt{\Delta p}}$$

At setting N, the k<sub>v</sub>-values are given for X<sub>p</sub> = 2 K. At lower presettings, X<sub>p</sub> is reduced for the k<sub>v</sub>-values stated to 0.5 K at preset value 1. The k<sub>v</sub>-values state Q at full flow, i.e. for a fully opened valve.

2) If sensor of types Danfoss Aveo®/Aero®/ React™/ Redia® or Remote Setting Unit is used, the P-band increases by a factor of 1.6. Manufacturer's value is at "N" setting.

	k <sub>v</sub> at X <sub>p</sub> = 2	k <sub>vs</sub>
VHS-UN 15	0.39	0.57

Temperature and pressure*	
Max. water temperature	120 °C
Recommended differential pressure	0.05-0.2 bar
Max. technical differential pressure	0.6 bar
Testing pressure	16 bar
Max. operating pressure	10 bar

\*The stated max. technical differential pressure indicates the limit for maintaining optimum control. For low-noise operation, system differential pressures should be held within the recommended range. Pumps should never be oversized; select those that generate just sufficient pressure to circulate the required volume of water. From experience, a differential pressure of 0.05-0.2 bar across the valve is adequate in most systems. In systems where it is too high, a Danfoss differential pressure regulator can be used to reduce it.

## Presetting

Danfoss pre-settable valve bodies incorporate easy setting adjustment collars with clearly engraved setting markers from 1 - 7 and N. Setting can be made quickly and precisely, without the need for tools, as follows:

- Remove protective cap or sensor element.
- Lift setting collar.
- Turn anti-clockwise to the desired engraved setting value. The setting mark always points directly to the radiator connection point.
- Allow setting collar to fall back to its original position.

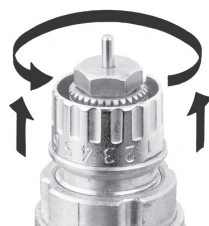

Preset levels can be selected in 0.5 increments between 1 and 7 (see chart for flow rates). At setting N the valve is fully open flushing option).

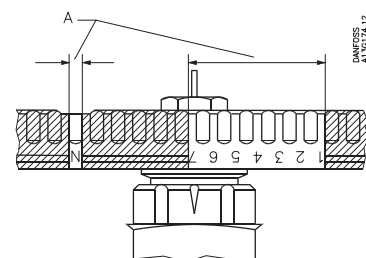







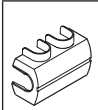

Settings in the hatched areas should be avoided.

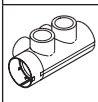
## Datasheet

## VHS Valve with Integrated Pre-Setting and Shut-Off/Drain

### Accessories

Product		Code no.
	Cover* for VHS valve for panel radiators, straight pattern, white RAL 9016, suitable for wet lacquering (see product carton)	<b>013G4774</b>
	Cover* for VHS valve for panel radiators, angle pattern, white RAL 9016, suitable for wet lacquering (see product carton)	<b>013G4775</b>
	Cover* for VHS valve for towel rail radiators, straight pattern, white RAL 9016, suitable for wet lacquering (see product carton)	<b>013G4674</b>
	Cover* for VHS valve for towel rail radiators, angle pattern, white RAL 9016, suitable for wet lacquering (see product carton)	<b>013G4673</b>
	Cover for VHS valve, straight pattern, chrome	<b>013G4780</b>
	Cover for VHS valve, angle pattern, chrome	<b>013G4779</b>
	Enclosure* for VHS valve for towel rail radiators, angle pattern, white RAL 9016, suitable for wet lacquering (see product carton)	<b>013G4755</b>
	Sealing cone incl. seal for valve radiator with 3/4" ext. thread (20 pcs.)	<b>003L0294</b>
	Self-sealing connection nipple for valve radiator with G½ int. thread (20 pcs.)	<b>003L0295</b>
	Double rosette (PVC) for pipe diameter Ø 12-24 mm (min. distance 50 mm)	<b>192H0161</b>
	Manual handwheel for all RA type valves (valve diff. pressure max. 0.6 bar)	<b>013G5002</b>
	Fill-and-drain fitting, not nickel-plated, with 3/4" ext. thread and hose nozzle	<b>003L0152</b>
	Connection bracket for sensors without snap-lock connection (10 pcs.)	<b>013G4925</b>
	Cover for VHS, nickel-plated	<b>003L0153</b>

\*Requires a sensor with snap-lock.

# Datasheet

# VHS Valve with Integrated Pre-Setting and Shut-Off/Drain

## Capacity

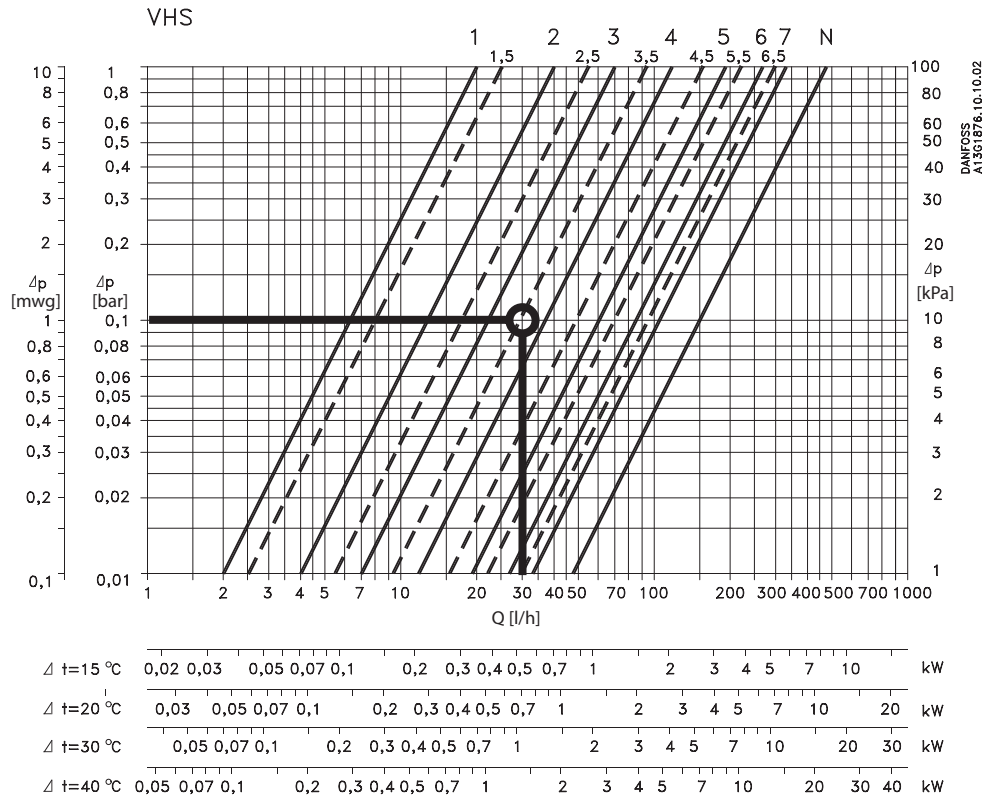

Capacities, using RA 2000 sensor elements at a P-band between 0.5 K and 2 K.

The capacity range of the VHS matches today's radiator performance figures. The amount by which the room temperature changes during operation is termed the P-band of a valve. This change is necessary to move the valve from the closed position to that at which the required volume flow (depending on dimensions) is achieved.

With the excellent control performance of RA2000 and RAW sensing elements, the valve should be sized for a P-band between 0.5 and 2K to achieve optimum energy saving under 'small room' temperature change conditions.

### Example of valve sizing

Heat requirement:	$Q = 0.7 \text{ kW}$
Temperature spread:	$\Delta T = 20^\circ\text{C}$
Water volume through radiator:	$Q = \frac{0.7}{20 \times 1.16} = 0.03 \text{ m}^3/\text{h} = 30 \text{ l/h}$
Pressure drop across the valve:	$\Delta p = 0.1 \text{ bar} \hat{=} 1 \text{ mW}$
Setting at valve:	VHS-UN 15: 3.5

Alternatively, the setting can be read directly from the "Ordering and data" table:

$$k_v = \frac{Q(\text{m}^3/\text{h})}{\sqrt{\Delta p (\text{bar})}}$$

## Draining the Radiators

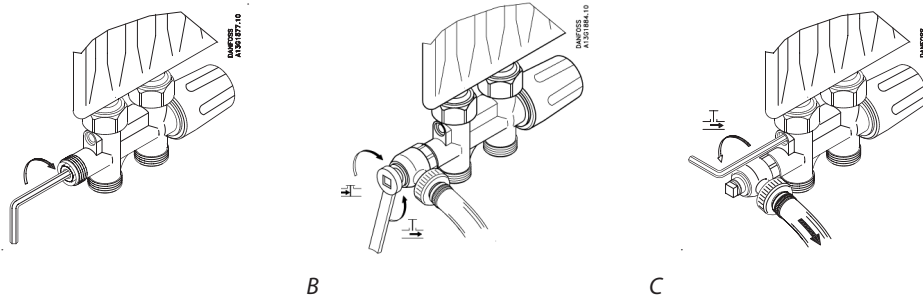
**Shut-off and draining**

If the sensor element is removed temporarily while the system is under pressure, it should be replaced by an appropriate handwheel – available from Danfoss - to ensure positive and safe shut-off.

To drain the radiator, first unscrew and remove the valve's metal cover. Then firmly shut off the return with an Allen key (see A).

Fix the drain fitting in position. Drain by turning the square headed drain screw to the left (see B).

The rising flow pipe in the radiator can be drained also by loosening the inner hexagonal screw (see C).

The accompanying hose nozzle can be rotated freely.

**Please note:**

The static pressure must not exceed 10 bar

## Design

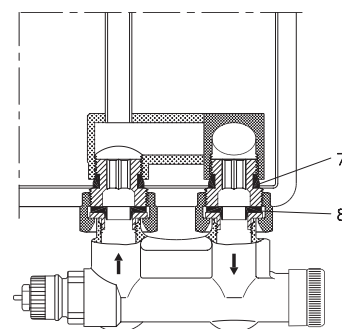
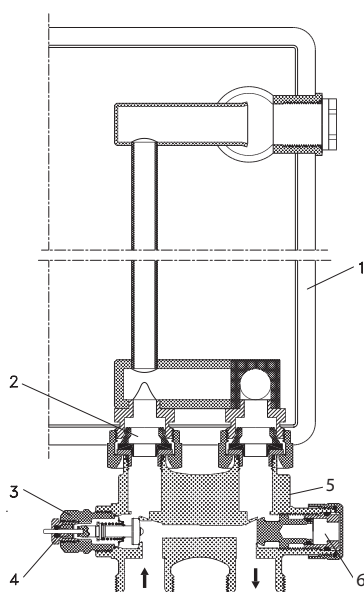

1. Radiator
2. Sealing cone
3. Valve insert, presettable, type RA-UN
4. Stuffing box
5. Draining screw for rising pipe
6. Block-off/drain of return
7. Connection nipple (self-sealing)
8. Flat packing

**Materials in contact with water**

Valve housing and other metal parts	Ms 58
O-rings	EPDM

Dimensions

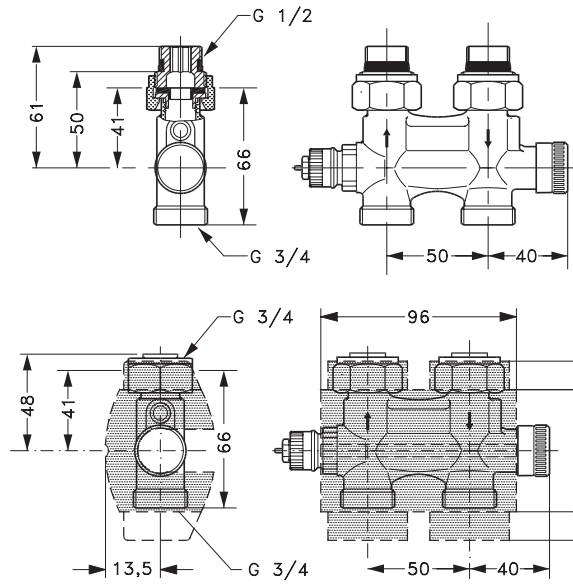

VHS straight pattern 1/2 or 3/4" radiator connection (covers are shaded grey).

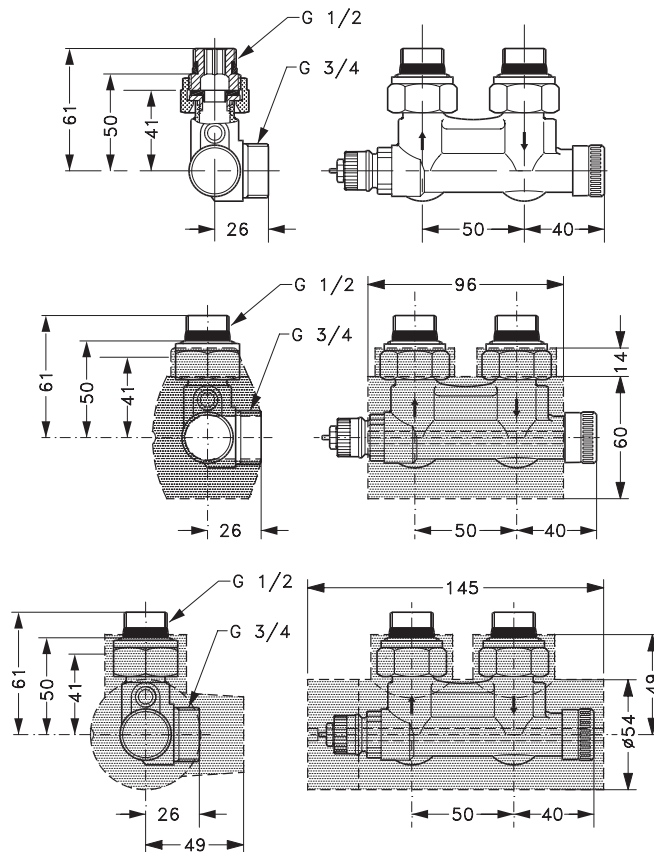

VHS angle pattern 1/2 or 3/4" radiator connection (covers are shaded grey).



**Danfoss A/S**

Climate Solutions • danfoss.com • +45 7488 2222

---

Any information, including, but not limited to information on selection of product, its application or use, product design, weight, dimensions, capacity or any other technical data in product manuals, catalogues descriptions, advertisements, etc. and whether made available in writing, orally, electronically, online or via download, shall be considered informative, and is only binding if and to the extent, explicit reference is made in a quotation or order confirmation. Danfoss cannot accept any responsibility for possible errors in catalogues, brochures, videos and other material. Danfoss reserves the right to alter its products without notice. This also applies to products ordered but not delivered provided that such alterations can be made without changes to form, fit or function of the product.

All trademarks in this material are property of Danfoss A/S or Danfoss group companies. Danfoss and the Danfoss logo are trademarks of Danfoss A/S. All rights reserved.

---