

Data sheet

ECL Comfort 110

230 V a.c. and 24 V a.c.

Description and application



ECL Comfort 110

The ECL Comfort 110 is a universal 1-circuit controller for use in district heating substations and district heating systems as well as boiler-based systems.

The product is an electronic controller for

- weather compensated flow temperature control (heating)
- constant temperature control (for example Domestic Hot Water, DHW)
- constant temperature control (DHW on demand)

In heating applications the ECL Comfort 110 can be integrated with the Danfoss Link™ solution via the DLG interface for use in single-family applications.

The controller is designed for easy installation: one cable, one connector.

The ECL Comfort 110 controller has a custom-designed display with backlight. For a quick overview, the display readouts are based on graphic symbols as well as text in various languages.

The controller has triac outputs for motorized control valve and relay outputs for pump control.

It is possible to connect up to 4 temperature sensors (Pt 1000 types) and it has 1 input for override.

The ECL Comfort 110 controller can be used as master or slave in ECL 100, ECL 110, ECL 200, ECL 300 and ECL 301 systems.

It is prepared for mounting on a DIN rail, a wall or in a panel.

ECL Comfort 110 works with a limited range of Danfoss actuators. See list.

Ordering
Controllers

Type	Designation	Code no.
ECL Comfort 110	Universal hardware - 230 V a.c. Base part included	087B1261
ECL Comfort 110	Universal hardware - 24 V a.c. Base part included	087B1251
ECL Comfort 110 with week schedule	Universal hardware - 230 V a.c. Base part included	087B1262
ECL Comfort 110 with week schedule	Universal hardware - 24 V a.c. Base part included	087B1252
Panel mounting kit	For ECL Comfort 110	087B1249

Literature

Type	Designation	Code no.
Instructions, appl. 116	User guide and quick guide (English)	087B8151
	User guide and quick guide (Danish)	087B8153
	User guide and quick guide (Swedish)	087B8155
Instructions, appl. 130	User guide and quick guide (English)	087B8152
	User guide and quick guide (Danish)	087B8154
	User guide and quick guide (Swedish)	087B8156

All other language versions are available on our website.

Go to <http://www.danfoss.com>.

In the 'Service and support' menu search for 'ECL 110' and select Documentation > Documents > Heating > your language

Pt 1000 temperature sensors

Type	Designation	Code No.
ESMT	Outdoor temperature sensor	084N1012
ESM-10	Room temperature sensor	087B1164
ESM-11	Surface sensor	087B1165
ESMB-12	Universal sensor	087B1184
ESMC	Surface sensor incl. 2 m cable	087N0011
ESMU-100	Immersion sensor, 100 mm, copper	087B1180
ESMU-250	Immersion sensor, 250 mm, copper	087B1181
ESMU-100	Immersion sensor, 100 mm, stainless steel	087B1182
ESMU-250	Immersion sensor, 250 mm, stainless steel	087B1183

Accessories, ECL 110 related

Type	Designation	Code no.
ECA 110*	Week schedule for ECL Comfort 110 (chip card)	087B1248
DLG**	Interface with power supply for system integration of ECL 110 and Danfoss Link™. Mounting Guide / Instructions are supplied with the product.	087H3241

*
The ECA 110 is a supplement to the ECL Comfort 110 versions without a week schedule, e.g., the code nos. 087B1261 and 087B1251 (see page 1). With the ECA 110 it will be possible to set personal schedules in terms of start and stop times of the system and thereby optimize the energy supply.

**
The CC panel of the Danfoss Link™ system has to be a Mk III v. 3.2.0 or newer.

Accessories, temperature sensor related

Pocket	Immersion, stainless steel 100 mm, for ESMU-100, Cu (087B1180)	087B1190
Pocket	Immersion, stainless steel 250 mm, for ESMU-250, Cu (087B1181)	087B1191
Pocket	Immersion, stainless steel 100 mm, for ESMB-12, (087B1184)	087B1192
Pocket	Immersion, stainless steel 250 mm, for ESMB-12, (087B1184)	087B1193

**Domestic hot water (DHW)
(Application 116)**

Application 116, example 1

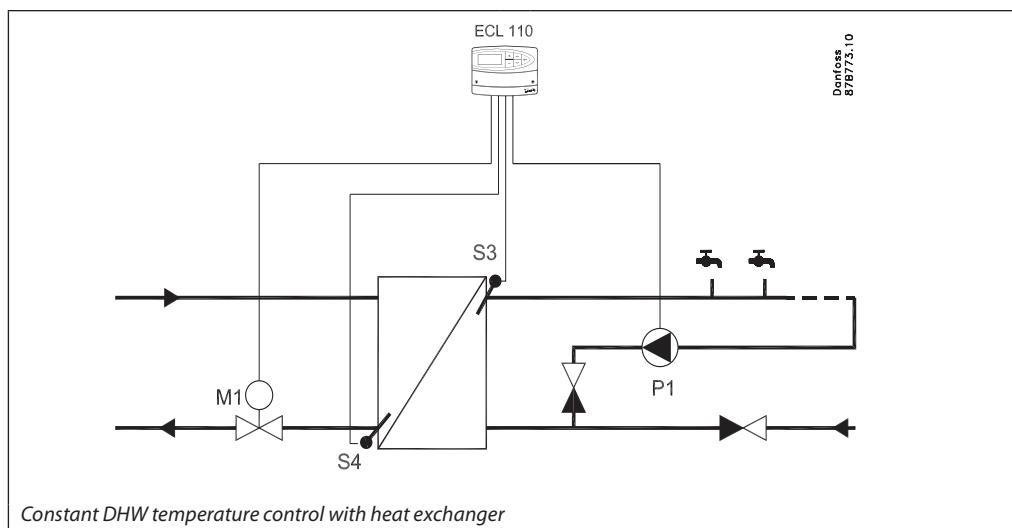

Basic principles

Constant DHW temperature control with heat exchanger or storage tank

Typically, the flow temperature is adjusted according to the desired flow temperature.

- Adjustment of DHW temperature
If the measured DHW temperature is lower than the desired temperature, the motorized control valve is opened gradually and vice versa.

- Return temperature limitation
The return temperature to the district heating supply should not be too high. If so, the desired flow temperature can be adjusted (typically to a lower value) thus resulting in a gradual closing of the motorized control valve. In boiler-based heating supply the return temperature should not be too low (same adjustment procedure as above).

- Circulation pump control
The circulation pump is ON when the desired DHW temperature is higher than a user-defined value (factory setting: 20 °C).

Application 116, example 2:

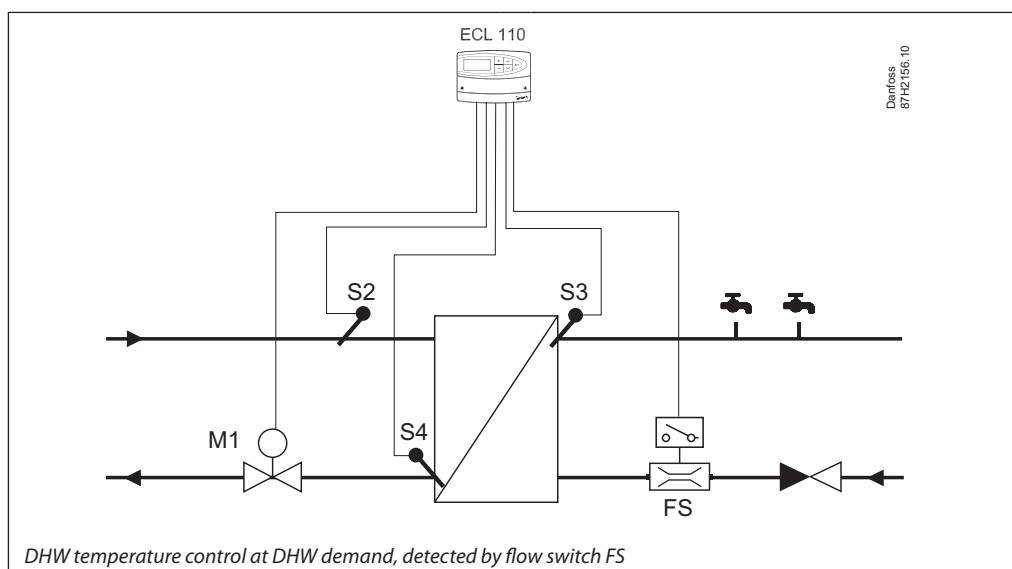

Basic principles

Desired DHW temperature, for example 55 °C, is controlled as long as a flow is detected by flow switch FS.

When no DHW flow is detected, the ECL 110 can maintain a minimum supply temperature at S2.

The temperature at S2 corrects the set Proportional band (X_p) in order to achieve stable control at different supply temperatures.

DHW circulation temperature, for example 55 °C, can be maintained.

Key functions

Flow temperature control

- Return temperature limitation
The controller automatically changes the desired flow temperature to obtain an acceptable return temperature when the return temperature falls below or gets higher than the set value. The return temperature influence factor is set in the ECL 110.

Safety functions

- Frost protection
The controller automatically switches the circulation pump ON when the flow temperature is lower than a user-defined value (factory setting: 10 °C).
- Motor protection
The controller prevents unstable temperature control thus resulting in a longer life of the motorized control valve and actuator.
- Pump exercise
Exercise of the pump to avoid blocking in periods without heat demand.

Optimization

- Auto tuning
A function for automatically setting the proportional band (X_p) and integration time constant (T_n).

Heating (Application 130)

Application 130 examples

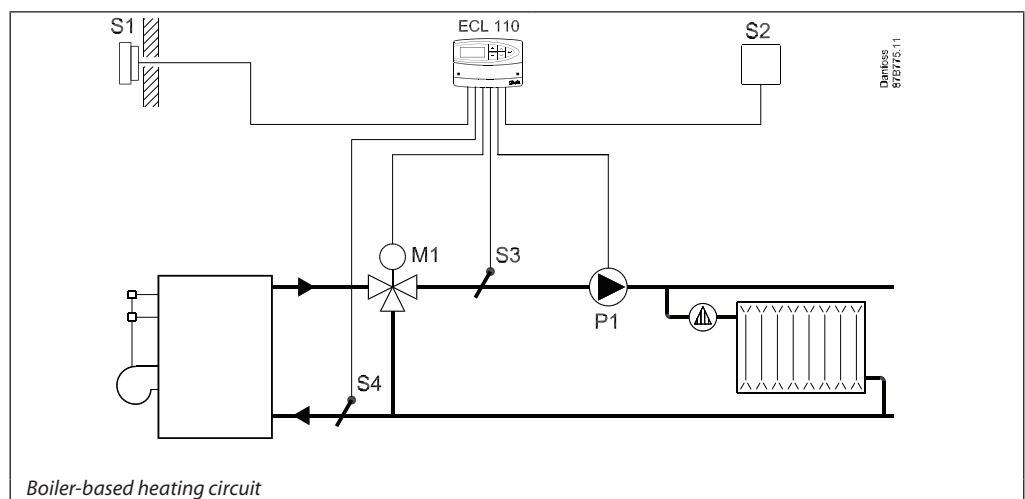
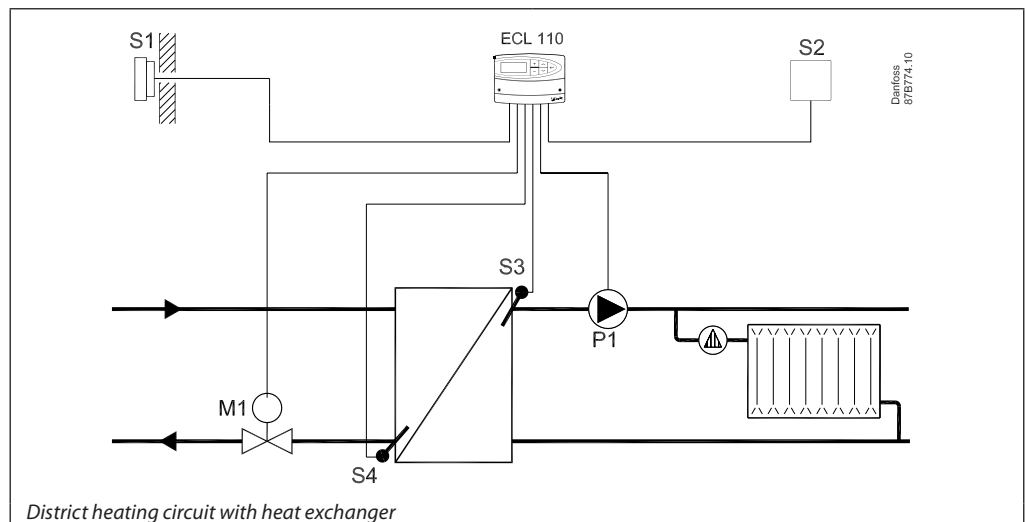

Basic principles

Control of district heating circuits with or without heat exchanger and for boiler-based heating circuits

Typically, the flow temperature is adjusted according to the desired room temperature. The desired room temperature (Comfort and Setback) can be determined by the week schedule.

- Adjustment of flow temperature
The desired flow temperature is calculated in the ECL Comfort controller, based on the outdoor temperature. The lower the outdoor temperature, the higher the desired flow temperature. The heat curve (relationship between outdoor temperature and desired flow temperature) is set by means of a slope value. Max. / min. limitation of the desired flow temperature can be set. The motorized control valve is opened gradually when the flow temperature is lower than the desired flow temperature and vice versa.

- Return temperature limitation
The return temperature to the district heating supply should not be too high. If so, the desired flow temperature can be adjusted (typically to a lower value) thus resulting in a gradual closing of the motorized control valve. In boiler-based heating supply the return temperature should not be too low (same adjustment procedure as above).
- Room temperature limitation
If the measured room temperature does not equal the desired room temperature, the desired flow temperature can be adjusted.
- Circulation pump control
The circulation pump is ON when the desired flow temperature is higher than a user-defined value (factory setting: 20 °C) or the outdoor temperature is lower than a user-defined value (factory setting: 2 °C).
- The heating cut-out function can switch OFF the heating and stop the circulation pump at high outdoor temperatures.

Application with Danfoss Link™

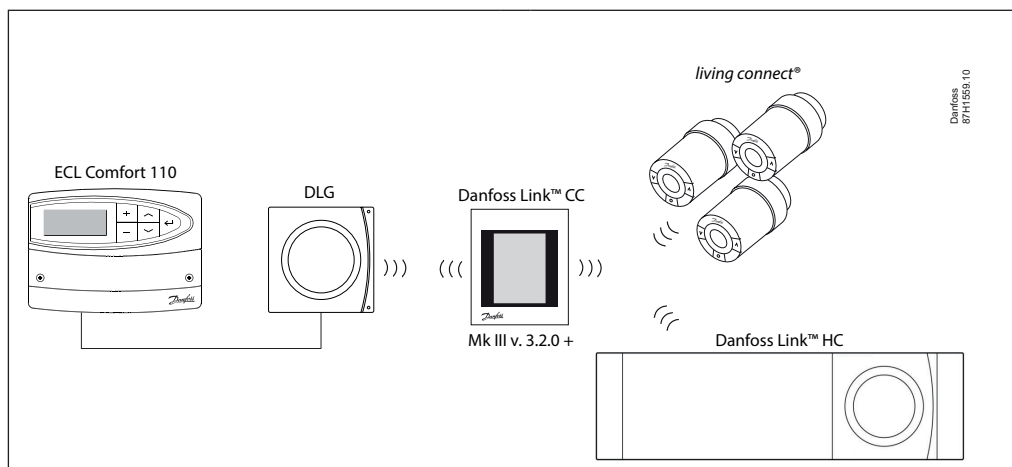

By system integration of ECL Comfort 110 and Danfoss Link™ via the DLG interface the following is achieved:

- Heating is ON whenever there is a demand
- Heating is operated from only one interface
- Heating comfort is achieved with the lowest energy consumption
- Outdoor temperature is shown in the Danfoss Link™ panel.

General data

Ambient temperature	0 - 55 °C
Storage temperature	-40 - + 70 °C
Enclosure	DIN rail, wall or panel
Sensor type	Pt 1000 (1000 Ω @ 0 °C)
Min. backup time for time and date	36 hours
Backup of settings and data	Flash memory
Date and time	The built-in Real Time Clock gives automatic Summer / Winter time changeover.
Grade of enclosure	IP 41 DIN 40050
CE - marking in accordance with the standards	EMC (ElectroMagnetic Compatibility Directive) LVD (Low Voltage Directive) RoHS (Restriction of Hazardous Substances Directive)
Languages, integrated and selectable in ECL 110	(alphabetic order) Danish, English, Estonian, Finnish, German, Latvian, Lithuanian, Polish, Russian and Swedish.

Wiring - 230 V a.c.

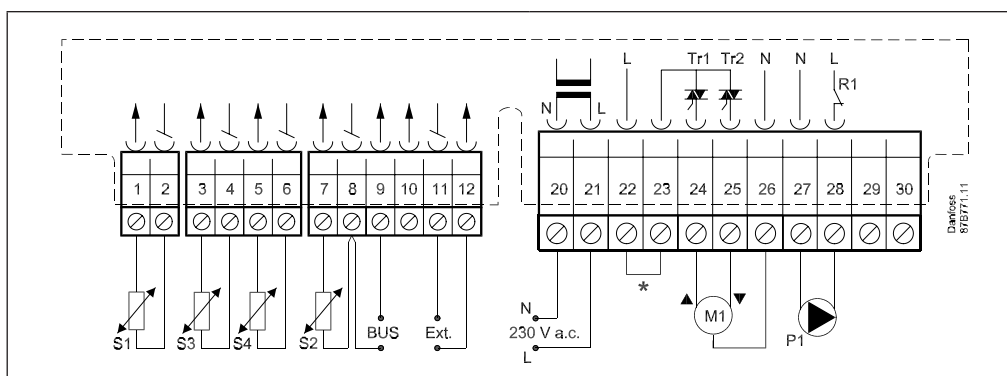

* Connections for safety thermostat

Supply voltage	230 V a.c. - 50 Hz
Voltage range	207 to 244 V a.c. (IEC 60038)
Power consumption	3 VA
Load on relay 1 outputs	4 (2) A - 230 V a.c.
Load on triac outputs	15 VA @ 230 V a.c.

Wiring - 24 V a.c.

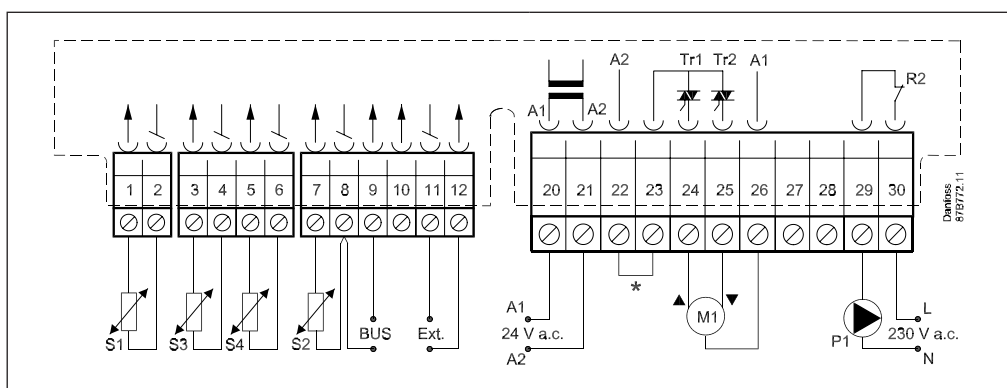

* Connections for safety thermostat

Supply voltage	24 V a.c. - 50 Hz
Voltage range	21.6 to 26.4 V a.c. (IEC 60038)
Power consumption	3 VA
Load on relay 2 outputs	4 (2) A - 230 V a.c.
Load on triac outputs	15 VA @ 24 V a.c.

Recommended actuator types

Types (Danfoss):	Remarks:
ABV series	Thermo-hydraulic, ON-OFF controlled; for seated valves
AMB 100 series	Gear-motor, 3-point controlled; for rotating valves
AMV 10 / 20 / 30 series	Gear-motor 3-point controlled; for seated valves
AMV 100 series	Gear-motor 3-point controlled; for seated valves

Operation

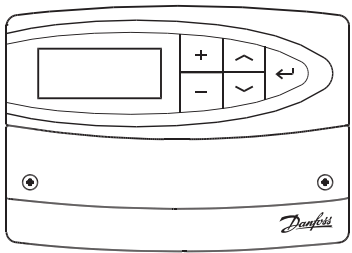



 **+**
 Adjust temperatures and values.

 **-**
 Adjust temperatures and values.

 **>**
 Switch between menu lines.

 **<**
 Switch between menu lines.

 **↵**
 Select / return.

 **↵** 2 sec.
 Return to daily user menu.

Menu navigation

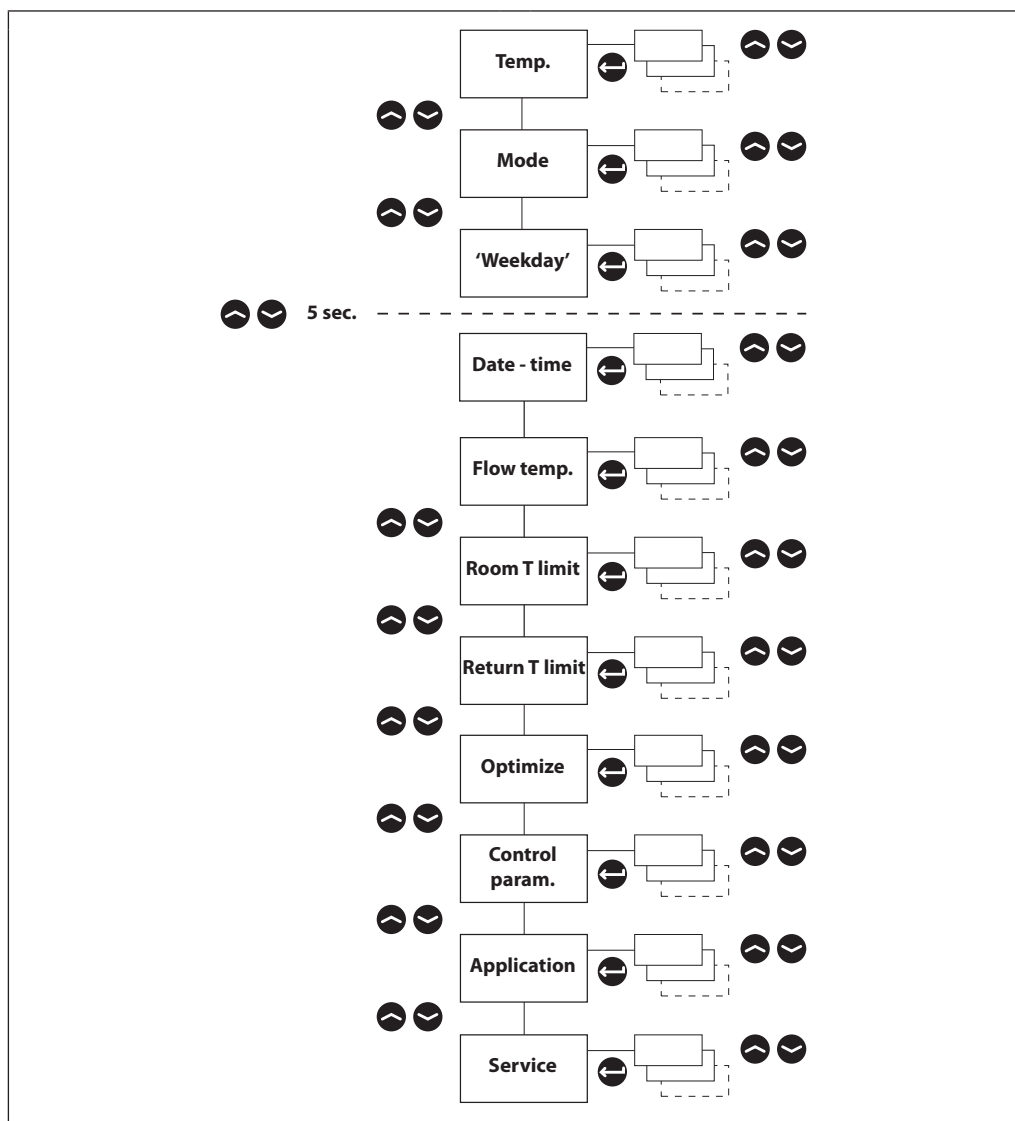

Dimensions

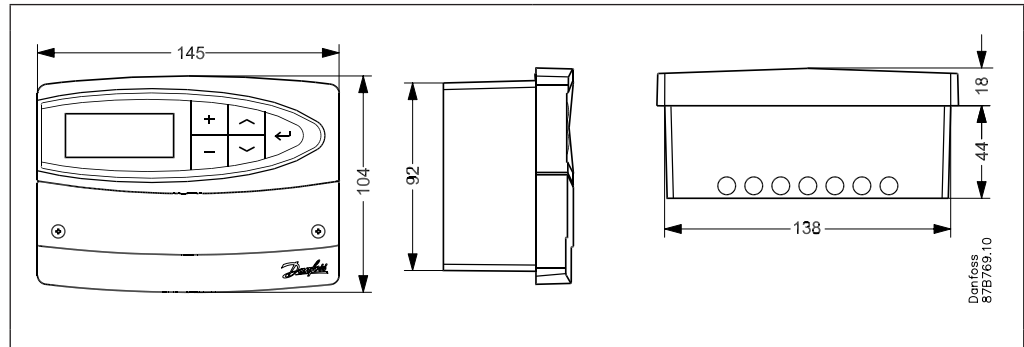

Cut-out for mounting

Mounting in a panel (panel mounting kit, code no.: 087B1249).

The panel thickness must not exceed 5 mm.

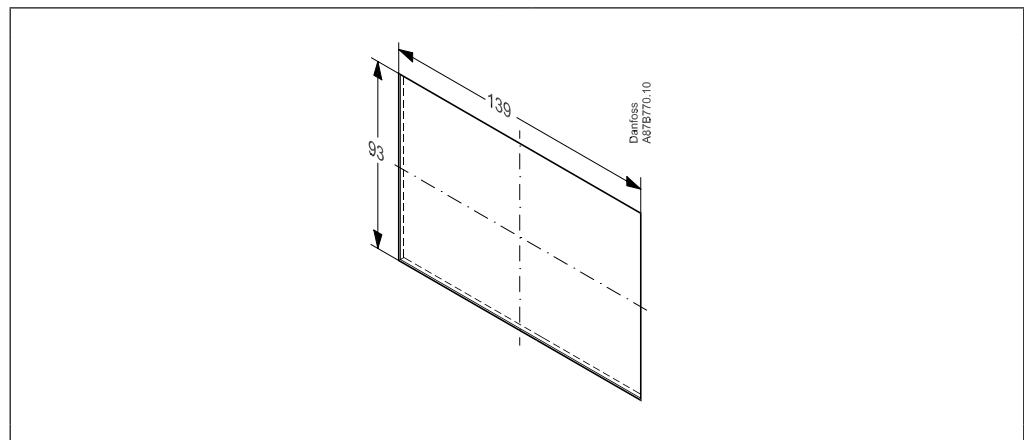

Additional documentation for ECL Comfort 110 is available on <http://heating.danfoss.com/>

Danfoss A/S

Heating Segment • heating.danfoss.com • +45 7488 2222 • E-Mail: heating@danfoss.com

Danfoss can accept no responsibility for possible errors in catalogues, brochures and other printed material. Danfoss reserves the right to alter its products without notice. This also applies to products already on order provided that such alterations can be made without subsequential changes being necessary in specifications already agreed. All trademarks in this material are property of the respective companies. Danfoss and all Danfoss logotypes are trademarks of Danfoss A/S. All rights reserved.