

Data sheet

Upgradable balancing valves

USV

Application / Description



USV valves are designed for manual hydronic balancing of heating and cooling systems.

USV-I (red knob) is used together with USV-M to limit the flow in heating or cooling installation or can work separately as manual balancing valves for flow limitation. If certain pipe sectors do not require a control of differential pressure, USV-I and USV-M can be used as shut-off- and measuring valve.

USV-M (blue knob) valve can be upgraded into an automatic USV-PV balancing valve. USV-M is designed for installation in the return pipe.

Upgrading from manual to automatic balancing is done by mounting PV-controller to an USV-M valve.

System does not need to be depressurized during the upgrade and the KV-values does not change. USV-PV maintains constant differential pressure across a riser.

Due to its special design USV-PV has a firm connection between diaphragm housing and valve cone. Diaphragm controller thus acts only against the force of reference spring. Excellent control of differential pressure is achieved by the following design characteristics:

- pressure released cone.
- adapted membrane for every valve dimension which provides constant quality of performances for all sizes.

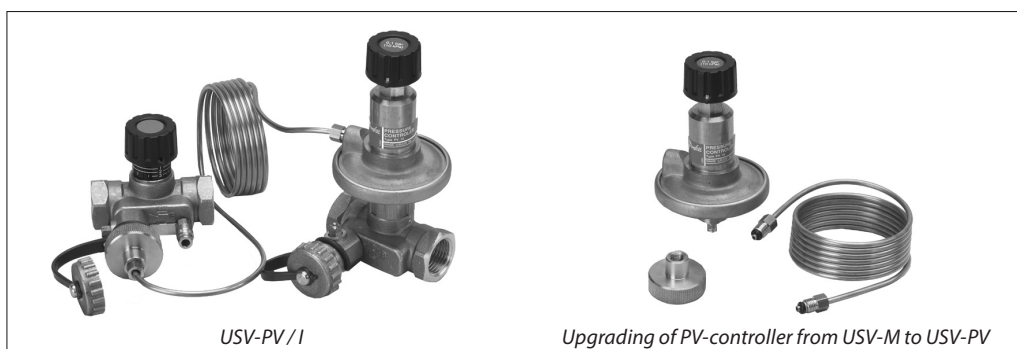

USV-PV (blue knob) is designed to maintain a constant set differential pressure across a riser. Eventual operating noise caused by high differential pressure induced by changes in the system can be avoided by upgrading the manual valve to the differential pressure controller.

USV-PV can be set to control the differential pressure between 0,05 bar to 0,25 bar (5 kPa to 25 kPa). The PV controller is factory pre-set to 0,1 bar (10 kPa). PV-controller upgrading set includes an impulse tube and a threaded connector for the drain connection of USV-I.

USV-M (PV) and USV-I are compact valves in which the operating elements and connections are placed within an arc of 90°, so that in spite of small valve dimensions, access for installation and operation is optimal. Insulation caps for temperature up to 80 °C or 120 °C are available as accessory.

USV-M and USV-I are supplied in a set-pack with internal or external thread. If an external thread is chosen, a threaded or welded plug can be supplied as an accessory.

Application / Description
(continued)

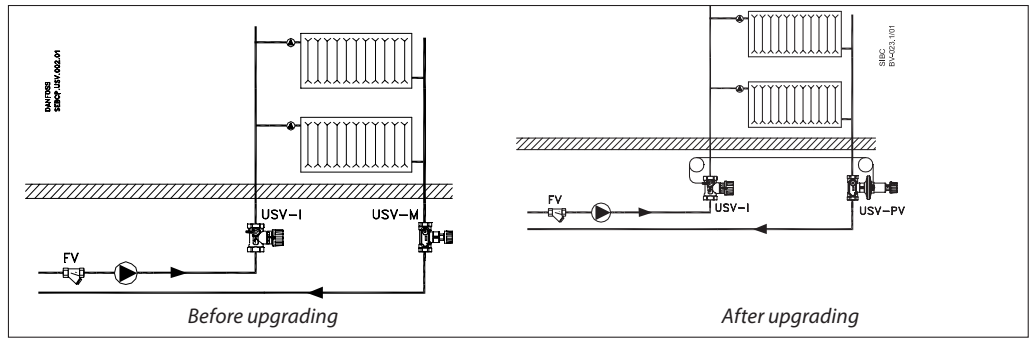

Upgradable USV valves are to be used for manual as well as automatic balancing of heating systems. If system has to be fitted with differential pressure controller, USV can be upgraded with PV controller.

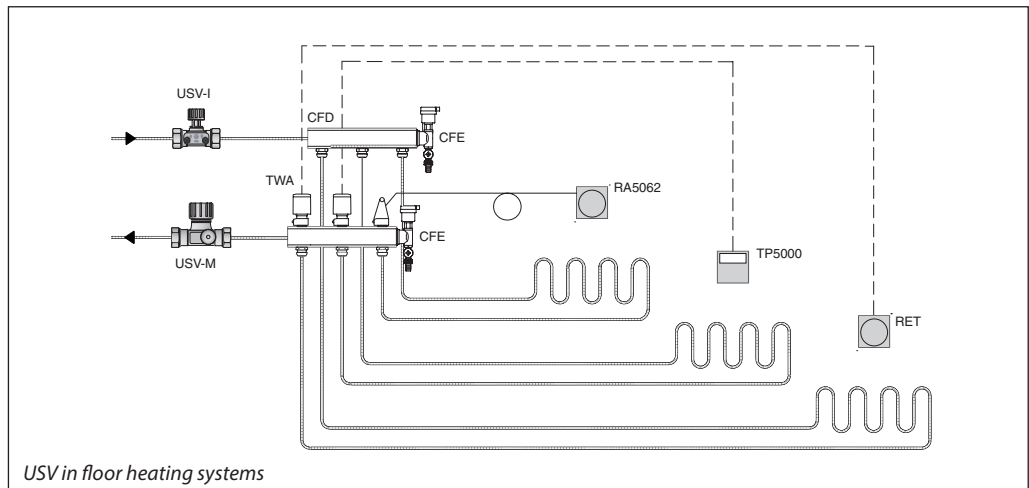

Upgradable control valves are to be used for manual balancing of a floor system manifold.

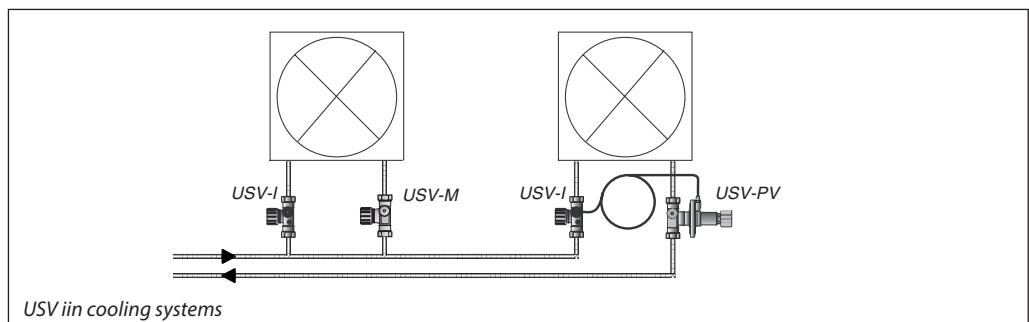

Upgradable USV control valves are to be used for manual or automatic hydronic balancing of cooling devices i.e. as fan coils or chilled ceilings.

Ordering

USV set-pack (containing one USV-M and one USV-I)

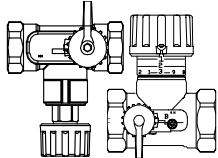
Type	DN	k_{vs} [m ³ /h]	Int. thread ISO 7/1	Code No.	Ext. thread ISO 228/1	Code No.
	15	1,6	R _p ½	003Z2141	G ¾ A	003Z2146
	20	2,5	R _p ¾	003Z2142	G 1 A	003Z2147
	25	4,0	R _p 1	003Z2143	G 1¼ A	003Z2148
	32	6,3	R _p 1¼	003Z2144	G 1½ A	003Z2149
	40	10	R _p 1½	003Z2145	G 1¾ A	003Z2150
	50*	16	R _p 2	003Z2155	G 2¼ A	003Z2160

*DN 50 is not upgradable

PV controller for upgrading USV-M valve

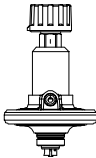
Type	DN	Comments	Code No.
	15	Include: impulse tube 1,5 m and threaded connector	003Z2156
	20		003Z2157
	25		003Z2158
	32		003Z2159
	40		

*It is not necessary to depressurize the system in order to upgrade into differential pressure controller.
K_v value does not change.*

USV-M valve

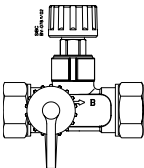
Type	DN	k_{vs} [m ³ /h]	Int. thread ISO 7/1	Code No.	Ext. thread ISO 228/1	Code No.
	15	1,6	R _p ½	003Z2121	G ¾ A	003Z2126
	20	2,5	R _p ¾	003Z2122	G 1 A	003Z2127
	25	4,0	R _p 1	003Z2123	G 1¼ A	003Z2128
	32	6,3	R _p 1¼	003Z2124	G 1½ A	003Z2129
	40	10	R _p 1½	003Z2125	G 1¾ A	003Z2130
	50*	16	R _p 2	003Z2153	G 2¼ A	003Z2154

*DN 50 is not upgradable

USV-I valve

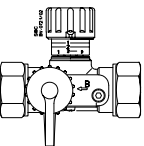

Type	DN	k_{vs} [m ³ /h]	Int. thread ISO 7/1	Code No.	Ext. thread ISO 228/1	Code No.
	15	1,6	R _p ½	003Z2131	G ¾ A	003Z2136
	20	2,5	R _p ¾	003Z2132	G 1 A	003Z2137
	25	4	R _p 1	003Z2133	G 1¼ A	003Z2138
	32	6,3	R _p 1¼	003Z2134	G 1½ A	003Z2139
	40	10	R _p 1½	003Z2135	G 1¾ A	003Z2140
	50	16	R _p 2	003Z2151	G 2¼ A	003Z2152

Technical data

Max. working pressure 16 bar
 Test pressure 25 bar
 Max. differential pressure across
 the valve (USV-M/PV) 0,8 bar (80 kPa)
 Max. differential pressure across
 the valve (USV-I) 1,5 bar (150 kPa)
 Flow temperature -20 to 120 °C

Material of parts in contact with water:
 Valve body, spindle, etc. Brass
 Cone (USV-M/PV) DZR Brass
 Diaphragm and O-rings EPDM
 Spring Stainless
 steel

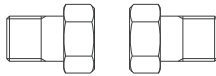
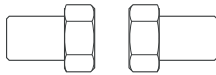
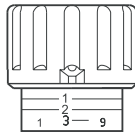
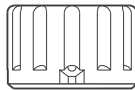
Accessories and spare parts

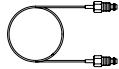
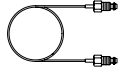
Type		Comments/connection	Code No.
Tailpiece threaded (for external thread only)		DN 15, G ¾ A	003N5070
		DN 20, G 1 A	003N5071
		DN 25, G 1¼ A	003N5072
		DN 32, G 1½ A	003N5073
		DN 40, G 1¾ A	065F6060
		DN 50, G 2¼ A	003L8162
Tailpiece welding (for external thread only)		DN 15, G ¾ A	003N5090
		DN 20, G 1 A	003N5091
		DN 25, G 1¼ A	003N5092
		DN 32, G 1½ A	003N5093
		DN 40, G 1¾ A	065F6080
		DN 50, G 2¼ A	003L8163
Shut-off knob for USV-I (black)		DN 15	003L8155
		DN 20	003L8156
		DN 25	003L8157
		DN 32	003L8158
		DN 40	003L8158
		DN 50	003L8158
Shut-off knob for USV-M (black)		DN 15	003L8146
		DN 20	003L8147
		DN 25	003L8148
		DN 32	003L8149
		DN 40	003L8149
		DN 50	003L8149
Drain connection			003L8141
Masuring connector		For drain connection	003L8143
Connection plug for impulse tube (spare part)		For drain connection	003Z0109
Impulse tube		1,5 m	003L8152
Impulse tube		5 m	003L8153
Insulation cap	up to 80 °C	DN 15	003L8165
		DN 20	003L8166
		DN 25	003L8167
		DN 32	003L8168
		DN 40	003L8169
		DN 50	003L8164
	up to 120 °C	DN 15	003L8170
		DN 20	003L8171
		DN 25	003L8172
		DN 32	003L8173
		DN 40	003L8139
		DN 50	003L8138

Design

- 1. Shut-off knob
- 2. Shut-off spindle
- 3. Setting spindle
- 4. Scale disc
- 5. O-rings
- 6. Valve cone
- 7. Valve body

DN	
15	2,5
20	3
25	4
32	5
40	5

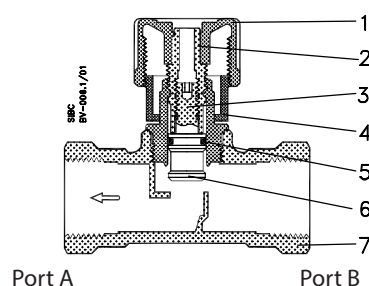

Fig. 8 USV-I

USV-I incorporates a double cone (3,6) able to give maximum stroke limitation, thus achieving flow limitation. It also incorporates shut off function. ASV-I is equipped with the plugs for the flow measurement and a connection for the USV-P/PV impulse tube.

Use the following procedure to limit the flow: turn the valve knob (1) fully counter clockwise to open the valve. The mark on the knob will now be opposite »0« on the scale (4). Turn the valve knob (1) clockwise to the required setting (e.g. for setting 2,2 the knob must be rotated two full turns and then forward to »2« on the scale. Hold

the knob (1) to keep the setting (e.g. 2,2) and using a hexagon socket key turn the spindle (3) fully counter clockwise (until a stop can be felt). Turn the valve knob (1) fully counter clockwise so that the mark on the knob is opposite »0« on the scale (4). The valve is now open as many turns from the closed position (2,2) as indicated by the conversion from required flow. To annul the setting, turn the hexagon socket key fully clockwise (until a stop can be felt).

Remember, at the same time the knob must be held on its »0« setting.

USV-M

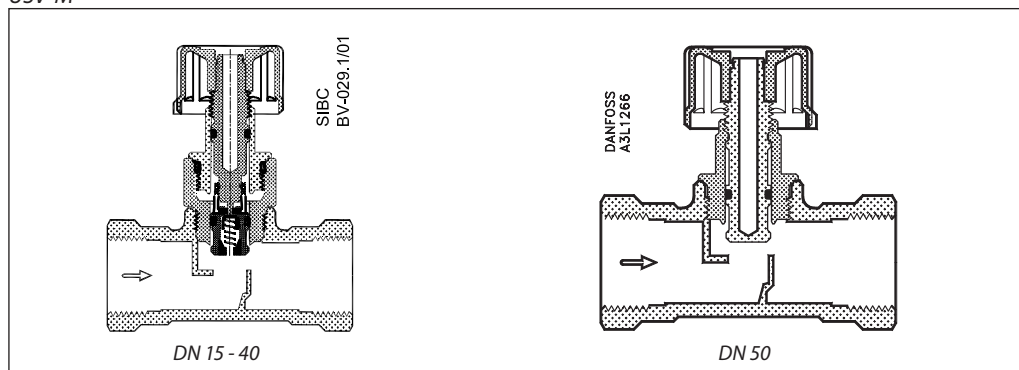

USV-M can be upgraded to USV-PV automatic balancing valve. The system does not need to be depressurized during the upgrade.

USV-M dimension DN 50 is not upgradable.

Design (continued)

1. Shut-off knob
2. Differential pressure setting spindle
3. O-ring
4. Reference spring
5. Impulse tube connection
6. Diaphragm element
7. Control diaphragm
8. Pressure-relieved valve cone
9. Valve body

USV-PV valve

DN	
15	2,5
20	3
25	4
32	5
40	5

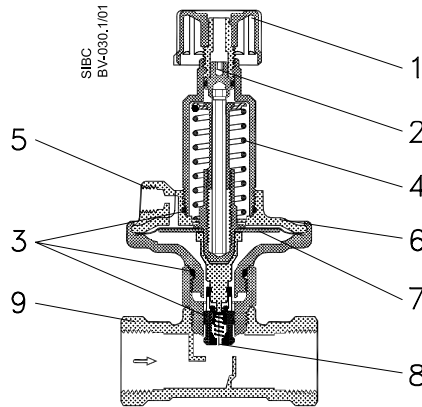

Turns (n)	bar
0	0,25
1	0,24
2	0,23
3	0,22
4	0,21
5	0,2
6	0,19
7	0,18
8	0,17
9	0,16
10	0,15
11	0,14
12	0,13
13	0,12
14	0,11
15 *	0,1
16	0,09
17	0,08
18	0,07
19	0,06
20	0,05

* Factory setting

USV-PV is designed to maintain a constant set differential pressure. Via an internal connection - trough the cone (8) and together with the reference spring (4), pressure in the return pipe acts on the underside of the control diaphragm (7) while via an impulse tube (5), pressure in the flow pipe acts on the top of the diaphragm. In this way the balancing valve maintains adjusted differential pressure in the riser.

USV-PV is factory-set on 0,1 bar (10 kPa). The differential pressure can be varied between 0,05 bar and 0,25 bar (5 kPa and 25 kPa).

Sizing

Required:

- A. Correct valve size USV-M / I
- B. Correct USV-I presetting

Given:

1. Required max. flow in the riser
Q = 0,80 [m³/h]
2. Pressure drop across riser
Δp_s = 15 [kPa]
3. Available pump pressure
Δp_o = 45 [kPa]

Solution:

A) Correct valve size :

Pipe size and low pressure drop (fully opened valve) can be criterions for valve selection.

The example selects USV-M 20 valve. Pressure drop is read from sizing diagram (page 8) by taking a horizontal line from DN 20 valve with presetting 3,2 (fully opened valve) to intersect with k_v-axis at 2,5 [m³/h].

A straight line connecting this point and Q = 0,80 [m³/h] intersects the differential pressure bar at Δp_v (USV-M) = 10 [kPa].

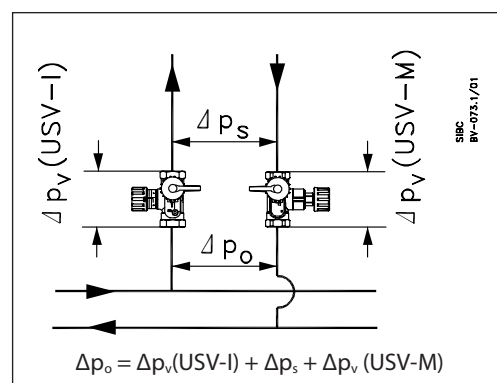

B) Correct valve size and presetting of USV-I:

The differential pressure across USV-I can be calculated as follows:

$$\Delta p_v(USV-I) = \Delta p_o - \Delta p_s - \Delta p_v(USV-M)$$

$$\Delta p_v = 45 [kPa] - 15 [kPa] - 10 [kPa] = 20 [kPa]$$

The example selects USV-I 20. Presetting is read from the sizing diagram (page 7) by taking a straight line from from max. flow Q = 0,80 [m³/h] to the differential pressure Δp_v (USV-I) = 20 [kPa] and to the intersection with k_v-axis at k_v = 1,8 [m³/h].

Draw a horizontal line from this point to the adjustment curve of the chosen valve (DN 20). Starting from closed valve, the presetting of 1,6 turns is required.

USV-PV

Required:

Diff. pressure setting of USV-PV

Given:

1. Required max. flow in the riser
Q = 0,80 [m³/h]
2. Pressure drop across riser
Δp_s = 15 [kPa]
4. Available pump pressure
Δp_o = 45 [kPa]

Solution:

USV-M is upgraded to USV-PV by mounting the PV controller to the USV-M valve and connecting it to the USV-I by the means of impulse tube. USV-PV maintains constant differential pressure Δp_a (pressure drop across riser - see fig.). USV-PV is to be set at Δp_a = 15 [kPa].

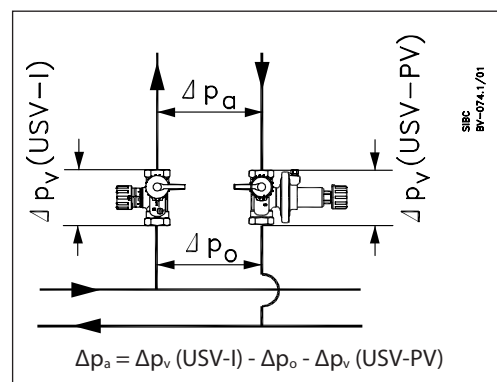

k_v-values [m³/h] for various presettings:

Size	Number of turns							
	0,20	0,60	1,00	1,40	1,80	2,20	2,70	3,20
DN 15	0,2	0,5	0,8	1,1	1,2	1,4	1,6	1,6
DN 20	0,3	0,8	1,3	1,6	1,9	2,1	2,4	2,5
DN 25	0,4	1,3	1,9	2,6	3,1	3,4	3,7	4,0
DN 32	0,7	2,0	3,1	4,1	4,9	5,4	5,9	6,3
DN 40	1,1	3,1	4,9	6,4	7,6	8,5	9,1	10,0
DN 50	1,7	4,9	7,6	10,0	11,9	13,3	14,4	16,0

Sizing (continued)

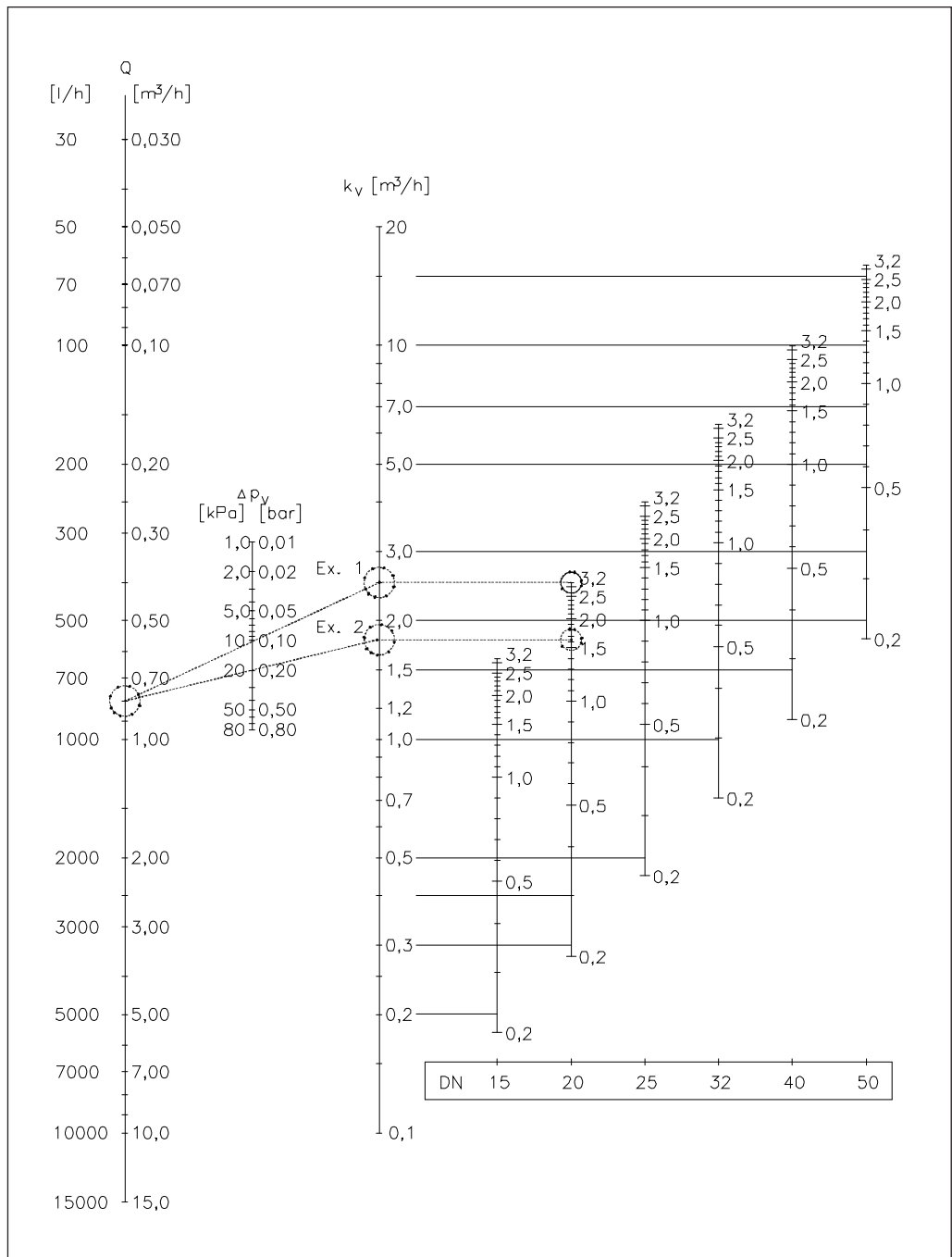

A straight line connecting the bars of flow, differential pressure and k_v value shows the relationship between these three variables.

A horizontal line from the intersection with the k_v bar shows the presetting value for each valve size.

$$k_v = \frac{10 \times Q}{\sqrt{\Delta p}}$$

Q [m³/h]
Δp [kPa]

Measurement of flow and differential pressure

USV-I is fitted with a test plug and a drain connection and the pressure drop across valve can be measured with Danfoss measuring device PFM 3000 or other standard devices. Using the pressure drop characteristics of USV-I and differential pressure of the fully opened valve, actual flow can be obtained.

Note:
When measuring the pre-set flow all radiator valves must be set for the nominal flow.

Differential pressure [Δp_r] measuring in the riserdes.
Drain connection of the USV-I and USV-M is to be fitted with a measuring connector (Danfoss **Code No. 003L8143**).

Installation

USV-I must be installed in the flow pipe. USV-M must be installed in the returned pipe. The direction of the flow must follow the direction of the arrow on the valve body. USV-M and USV-I can be installed in any positions if installation instructions are being observed. It is recommended that a filter i.e. Danfoss Typ FV is installed in the supply pipe. After upgrading USV-M to USV-PV the impulse tube between USV-I and USV-PV must be flushed through before installation.

A 90° angle between service features (shut-off on the one side, measuring and draining on the other), allow upside down installation and easy measuring, shut-off and draining of the system.

Pressure testing

Max. test pressure 25 bar

When pressure testing the system you must secure that both sides of the membrane have the same static pressure to prevent damage of the pressure controller. That means the impulse tube must be connected and any needle valves must be open.

If USV-PV is installed in combination with USV-I, both valves can be open or closed (both valves must be in the same position!).

Dimensions

Ext. thread
With tailpiece welding With tailpiece threaded

Int. thread

Type	L ₁ [mm]	L ₂ [mm]	L ₃ [mm]	H ₁ [mm]	H ₂ [mm]	D ₁ [mm]	S [mm]	a ISO 7/1	b ISO 228/1	Weight [kg]
USV-I 15	65	131	139	48	15	28	27	R _p ½	G ¾ A	0,31
USV-I 20	75	147	159	60	18	35	32	R _p ¾	G 1 A	0,4
USV-I 25	85	169	169	75	23	45	41	R _p 1	G 1¼ A	0,67
USV-I 32	95	191	179	95	29	55	50	R _p 1¼	G 1½ A	1,1
USV-I 40	100	202	184	100	31	55	55	R _p 1½	G 1¾ A	1,22
USV-I 50	130	246	214	106	38	55	67	R _p 2	G 2¼ A	2

Ext. thread
With tailpiece welding With tailpiece threaded

Int. thread

Type	L ₁ [mm]	L ₂ [mm]	L ₃ [mm]	H ₁ [mm]	H ₂ [mm]	D ₁ [mm]	S [mm]	a ISO 7/1	b ISO 228/1	Weight [kg]
USV-M 15	65	131	139	61	15	28	27	R _p ½	G ¾ A	0,28
USV-M 20	75	147	159	76	18	35	32	R _p ¾	G 1 A	0,4
USV-M 25	85	169	169	96	23	45	41	R _p 1	G 1¼ A	0,73
USV-M 32	95	191	179	121	29	55	50	R _p 1¼	G 1½ A	1,28
USV-M 40	100	202	184	126	31	55	55	R _p 1½	G 1¾ A	1,35
USV-M 50	130	246	214	106	38	55	67	R _p 2	G 2¼ A	2

Dimensions (continued)

