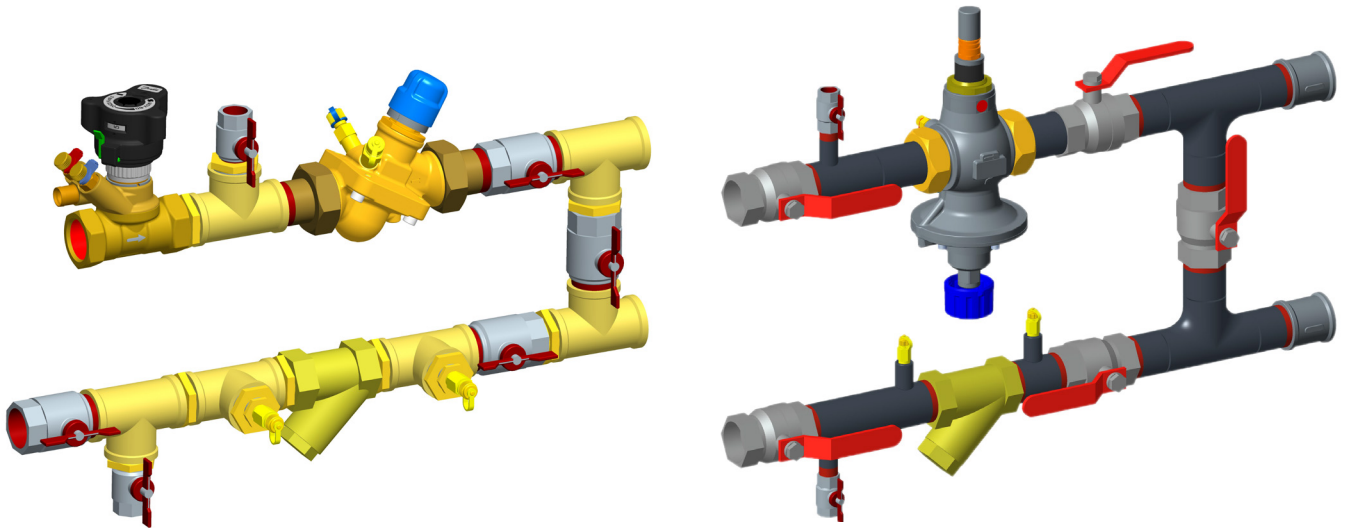

**Data sheet**

# Pre-Fabricated Flushing Bypass Assembly for Plant Applications **Hero Plant DN15-150**

**Description**

Hero Plant is a pre-fabricated, flushing bypass arrangement for balance, control, isolation, and operation of plant devices.

Flow is controlled by the AB-QM pressure independent control valve to avoid over flow and optimize the efficiency of terminal unit. The flow rate can be accurately verified via MSV (DN 15-32) and via AB-QM (DN 40-150).

Key features include:

- A compact, pre-fabricated design
- Factory pressure tested assembly to PED standard
- PN16 screwed connections DN15-50, and flanged connections DN65-150
- A wide flow rate range for all applications
- Danfoss AB-QM type pressure independent control valve for balance at full or partial loads
- A comprehensive compatible range of actuators to enable it to be connected to a building management system or other controller
- Strainer to remove particles from the system and prevent plant performance deterioration
- Flow and return mounted drains for flushing and quick draindowns
- Flow measurement function in all sizes

**Application**

Hero Plant is designed for use with air handling units, heat exchangers, heater batteries and all other plant devices, where flow is controlled via a pressure independent control valve, and isolation, drain, strain, flushing bypass, and flow measurement is required.

Schematic and design

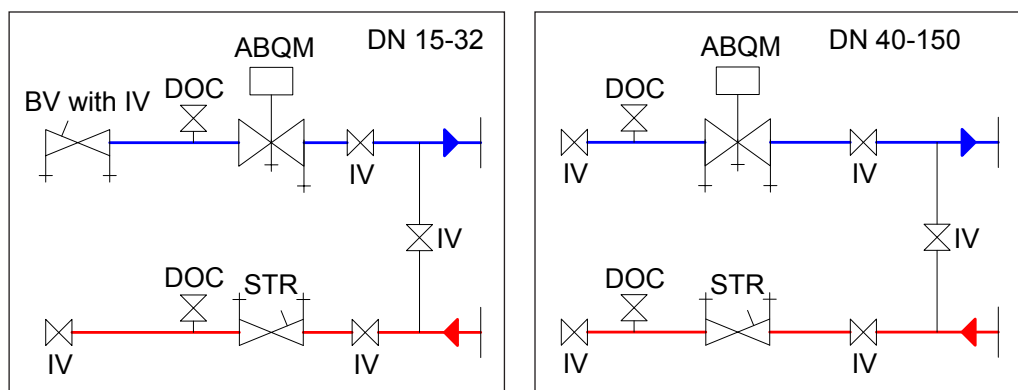

Schematic symbol Guide

- ABQM Pressure Independent Control Valve (actuator supplied separately)
- DOC Drain point
- IV Isolation valve
- STR Strainer
- ⊥ Test point
- BV MSV Balancing valve with built in measuring station and isolating valve

Materials

Component		Size										
		15	20	25	32	40	50	65	80	100	125	150
AB-QM	Body	DZR brass				Grey Iron GG25						
	Membrane and O-ring Material	EPDM									W.Nr.1.4571 /EPDM	EPDM
	Control Valve cone material	CuZn40Pb3-CW614N									W.Nr.1.4404 NC	W.Nr.1.4021
Strainer	Body	CW 617 N					Grey Iron GG25					
Isolating valves	Body	CW 617 N - Nickel Plated					Grey Iron GG25					
	Ball/Disk	CW 617 N - Chrome Plated					GGG40 with Polyamide coating					
MSV		DZR brass				N/A						
Pipe and flanges		P235GH / P265GH										
Fittings		CW617 / CW615										
Flanges		N/A					P245GH / P250GH					
Bolting		N/A					8.8 Zinc Plated					

**Ordering**

DN	Flow [l/h]		Connection		Description	Order code	Actuator*			
	Nominal	Minimum	Size (BSP)	Type			Type	Control signal	Supply voltage	Order code
15	450	90	1/2"	Internal thread	Hero Plant DN 15	146B5928	AME 110NLX	0-10V	24V AC	082H806000
20	900	180	3/4"		Hero Plant DN 20	146B5929				
25	1 700	340	1"		Hero Plant DN 25	146B5930				
32	3 200	640	1 1/4"		Hero Plant DN 32	146B2683				
40	7 500	3 000	1 1/2"		Hero Plant DN 40	146B2684				
50	12 500	5 000	2"	Flanged	Hero Plant DN 50	146B2685	AME 435QM	0-10V	24V AC/DC	082H017100
65	20 000	8 000	2 1/2"		Hero Plant DN 65	146B2686				
80	28 000	11 200	3"		Hero Plant DN 80	146B5931				
100	38 000	15 200	4"		Hero Plant DN 100	146B5932				
125	90 000	36 000	5"		Hero Plant DN 125	146B5933				
150	145 000	58 000	6"	Hero Plant DN 150	146B5934	AME 55QM	0-10V	24V AC	082H307800	

\* Actuators need to be ordered separately

**Technical data**

Size		15	20	25	32	40	50	65	80	100	125	150
Flow range	Nom l/s	0.125	0.25	0.47	0.89	2.08	3.47	5.56	7.78	10.56	25	40.28
	Min l/s	0.025	0.05	0.094	0.178	0.83	1.39	2.22	3.11	4.22	10	16.11
Setting range		20-100%					40-100%					
Differential Pressure	kPa	16-400			20-400			30-400				
PN Rating	Bar	16										
Control range		1:1000										
PICV Leakage rate		No visible Leakage		Maximum 0.05% of nominal flow								
Flow medium		Water and water mixtures for closed heating and cooling systems according to plant type I for DIN EN14868										
Medium Temperature	°C	-10...120										
Storage and transport Temperature	°C	-40...70										
Stroke	mm	2.25		4.5		10		15		30		
Connection		Union tread										
Drain	Size	1/2"						3/4"		1"		
	Type	1/4 Turn Ball										
	Flow rate l/s@1.2 bar ΔP	6						13.7		18.2		
Measuring Orifice	Model	MSV-BD					ABQM P1-P2					
	Type	Variable Orifice										
	Measuring orifice kVs at nominal flow	3	6.6	9.5	18	25	35	45	69.5	111	172	274
Strainer	Type	Threaded						Flanged PN 16				
	kVS	3.5	4.3	8.7	16.5	13.4	25.7	86	127	183	316	489
	Mesh Size mm <sup>2</sup>	1						0.87	1.18			
Isolating valve	Model	954						VFY-LH				
	kVs	20	45	60	100	170	265	174	275	496	883	1212
	Type	1/4 Turn Ball						Fully Lugged Butterfly				

**Operational modes**

**Supply**

This is the normal operation of the Hero, with flow going through the coil or heat exchanger, and out through the return, back to the system.

The AB-QM valve will balance by limiting the flow to the coil, and the actuator will control flow as per the temperature requirement.

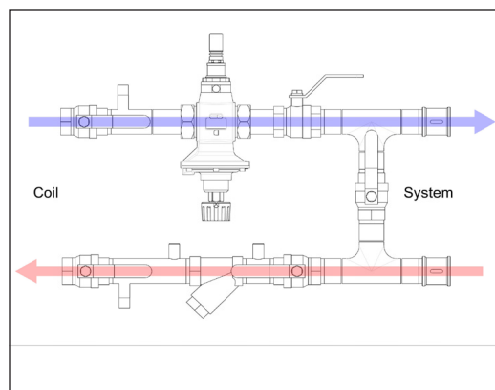

**Bypassing**

During system flushing, the coil will be isolated, but a flow around the main system is required. To enable bypassing we have positioned a flushing bypass within the Hero assembly, which can open a link between flow and return, to enable mainline system flow for flushing.

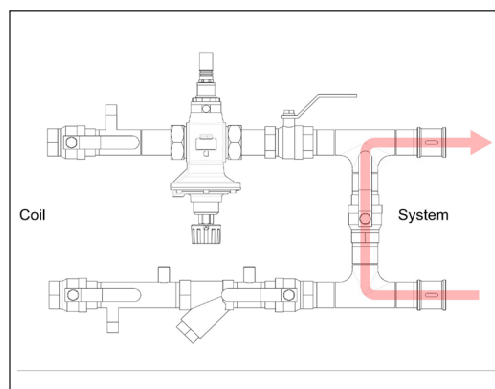

**Isolation**

For a variety of reasons, it may be required to completely isolate the coil or heat exchanger. For this we can isolate the flow and return, and close the bypass, to remove all flow through the coil and bypass.

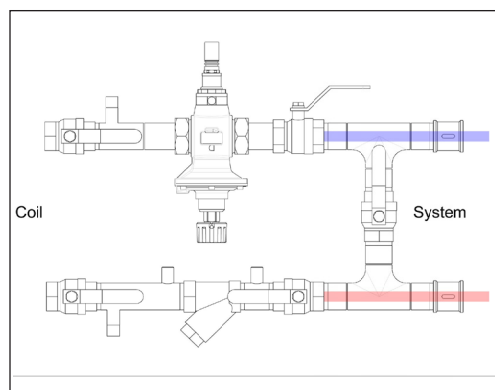

**Coil Flushing**

To enable flushing through the coil, the flow can be opened, with the return and bypass isolation valves closed. The drain is then opened, to allow flow through the coil, and any coil debris will be released through the return side drain point.

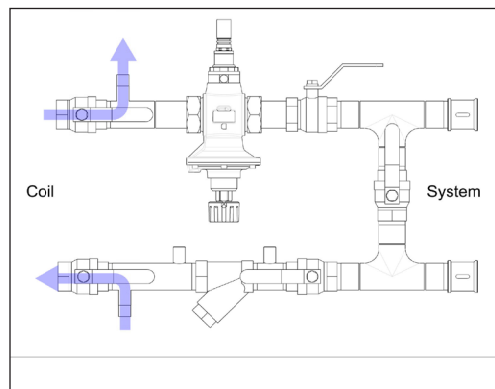

**Setting and flow measurement**

**Setting the AB-QM DN15-32**

The calculated flow can be adjusted easily without using special tools. To change the presetting (factory setting is 100%) follow the four steps below:

1. Remove the blue protective cap or the mounted actuator
2. Raise the grey pointer
3. Turn (clock wise to decrease) to the new presetting
4. Press grey pointer back into lock position.

After click presetting is locked.

The presetting scale indicates values from 100% flow to 0%. Clock wise turning would decrease the flow value while counter clock wise would increase it.

If the valve is a DN 15 then the nom flow

= 450 l/h =100% presetting. To set a flow of 270 l/h you have to set:  $270/450 = 60\%$ .

Danfoss recommends a presetting/flow from 20% to 100%. Factory presetting is 100%.

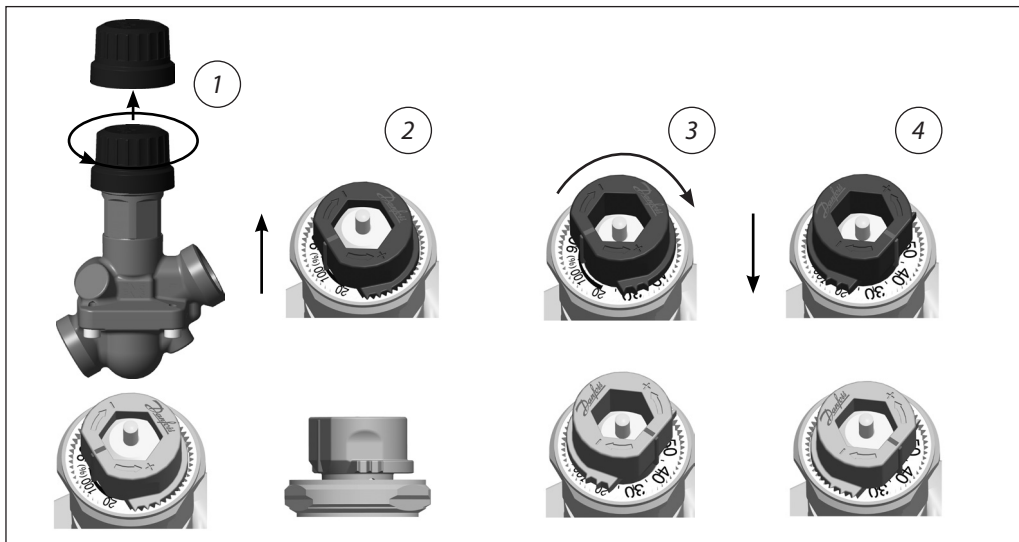

**Setting ABQM DN40-100**

1. Disconnect the actuator
2. One turn down of the setting ring equals 10% reduction in flow
3. Turn the setting ring until the desired % setting is in place
4. Reconnect the actuator

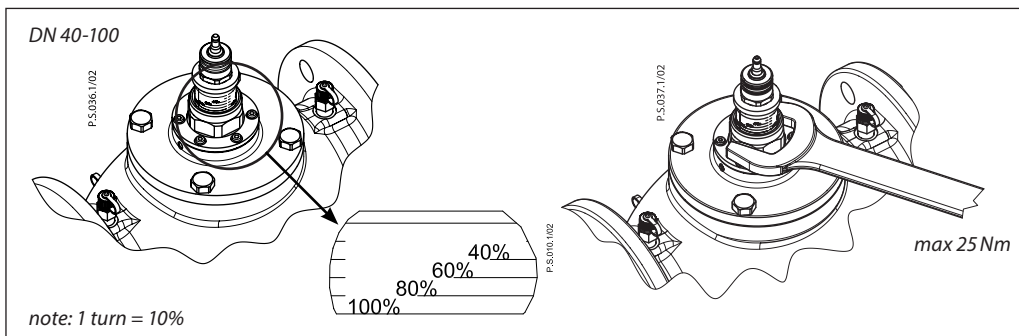

**Setting ABQM DN125-150**

1. Disconnect the actuator
2. One turn down of the setting ring equals 5% reduction in flow
3. Turn the setting ring until the desired % setting is in place
4. Reconnect the actuator

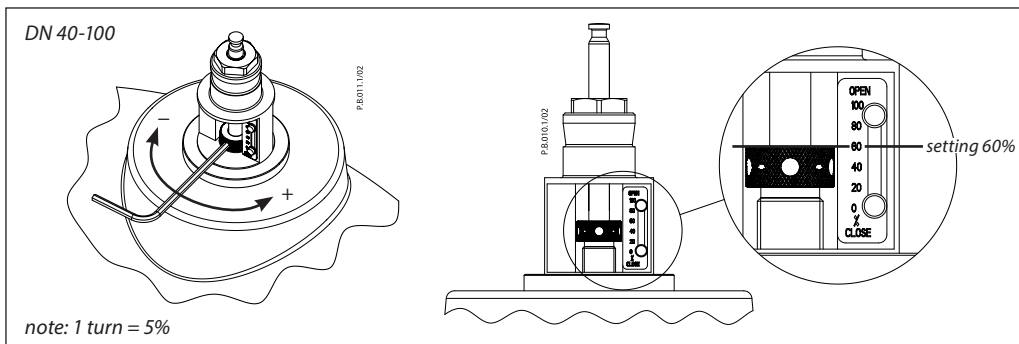

**Verification of Flow Rate on Hero DN15-32**

To verify the flow rate, the following steps should be taken:

1. Find the kVs of the MSV valve on the kVs chart
2. Calculate the required pressure drop using the kVs and design flow rate, using the following formula:

$$Q = K_v \times \sqrt{\Delta P}$$

Note Q=m<sup>3</sup>/h, ΔP=Bar

3. Plug a manometer into the test points on the MSV balancing valve
4. If you are getting the required pressure, you have the desired flow rate

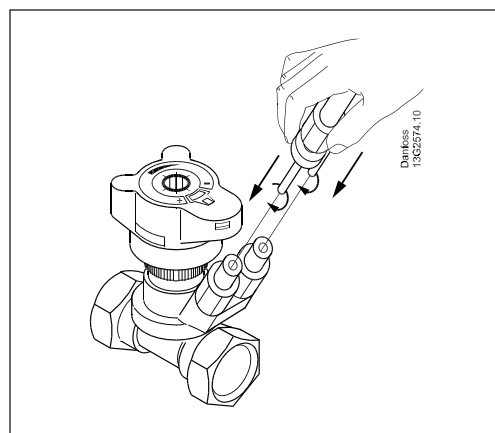

**Verification of Flow Rate on Hero DN40-150**

To verify the flow rate, the following steps should be taken:

1. Find the kVs of the AB-QM valve on the kVs chart
2. Calculate the required pressure drop using the kVs and design flow rate, using the following formula:

$$Q = K_v \times \sqrt{\Delta P}$$

Note Q=m<sup>3</sup>/h, ΔP=Bar

3. Plug a manometer into the P1-P2 test points (flow side to centre test point on the ABQM valve)
4. If you are getting the required pressure, you have the desired flow rate

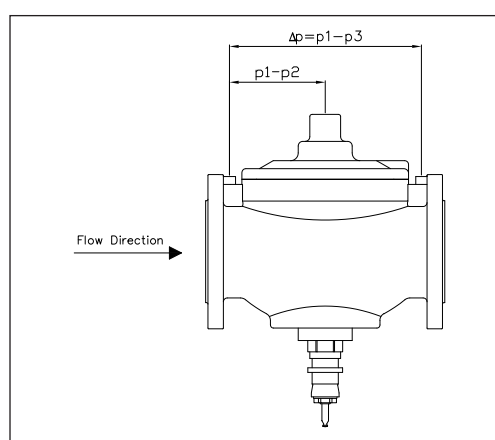

**Kvs chart MSV-BD**

**Hero DN15-32**

Setting	DN 15	DN 20	DN 25	DN 32
0	0.1	0.12	0.34	0.51
0.3	0.13	0.26	0.61	1.1
0.6	0.19	0.45	0.79	1.6
0.9	0.26	0.67	0.95	2.18
1.2	0.34	0.89	1.14	2.87
1.5	0.44	1.09	1.37	3.64
1.8	0.54	1.3	1.65	4.48
2.1	0.65	1.53	1.96	5.35
2.4	0.77	1.78	2.29	6.27
2.7	0.89	2.07	2.65	7.29
3	1.01	2.4	3.01	8.48
3.3	1.12	2.78	3.37	9.87
3.6	1.25	3.19	3.74	11.46
3.9	1.41	3.61	4.13	13.12
4.2	1.59	4.02	4.53	14.52
4.5	1.81	4.4	4.98	
4.8	2.08	4.72	5.46	
5	2.23	4.9	5.81	
5.2	2.36	5.04	6.19	
5.5	2.5	5.18	6.77	
5.8		5.27	7.34	
6.1			7.85	
6.4			8.17	
6.6				

Kvs chart AB-QM

Hero DN40-150

Presetting %	DN 40	DN 50	DN 65	DN 80	DN 100	DN 125	DN 150
20,0	3,40	4,60	4,20	15,50	19,50	40	53
22,5	4,08	5,55	5,48	17,19	21,94	45	60
25,0	4,80	6,50	6,75	18,88	24,38	49	67
27,5	5,43	7,45	8,03	20,56	26,81	53	74
30,0	6,10	8,40	9,30	22,25	29,25	57	81
32,5	6,78	9,35	10,58	23,94	31,69	61	88
35,0	7,50	10,30	11,85	25,63	34,13	65	95
37,5	8,13	11,25	13,13	27,31	36,56	69	101
40,0	8,80	12,20	14,40	29,00	39,00	73	108
42,5	9,48	13,15	15,68	30,69	41,44	77	115
45,0	10,20	14,10	16,95	32,38	43,88	82	122
47,5	10,83	15,05	18,23	34,06	46,31	86	129
50,0	11,50	16,00	19,50	35,75	48,75	90	136
52,5	12,18	16,95	20,78	37,44	51,19	94	143
55,0	12,90	17,90	22,05	39,13	53,63	98	150
57,5	13,53	18,85	23,33	40,81	56,06	102	157
60,0	14,20	19,80	24,60	42,50	58,50	106	163
62,5	14,88	20,75	25,88	44,19	60,94	110	170
65,0	15,55	21,70	27,15	45,88	63,38	114	177
67,5	16,26	22,65	28,43	47,56	65,81	119	184
70,0	16,90	23,60	29,70	49,25	68,25	123	191
72,5	17,58	24,55	30,98	50,94	71,81	127	198
75,0	18,25	25,50	32,25	52,63	75,38	131	205
77,5	18,93	26,45	33,53	54,31	78,94	135	212
80,0	19,60	27,40	34,80	56,00	82,50	139	219
82,5	20,28	28,35	36,08	57,69	86,06	143	225
85,0	20,95	29,30	37,35	59,38	89,63	147	232
87,5	21,63	30,25	38,63	61,06	93,19	152	239
90,0	22,30	31,20	39,90	62,75	96,75	156	246
92,5	22,98	32,15	41,18	64,44	100,31	160	253
95,0	23,65	33,10	42,45	66,13	103,88	164	260
97,5	24,33	34,05	43,73	67,81	107,44	168	267
100,0	25,00	35,00	45,00	69,50	111,00	172	274

For DN40-150, ensure the measurement is taken across the AB-QM for flow verification. The test points on the flow inlet to centre (P1-P2) should be used for this calculation

Installation

Hero units should be installed horizontally to ensure the strainer collects particles from the system. Vertical mounting is possible. Be aware that the strainer retains the particle but cannot collect them. Should an option for vertical mounting be required, contact your Danfoss representative for a design specific to your application. The components are installed to enable rotation whilst installed, should they clash with other closely located items. Once rotated, the connections should be re-checked for leaks. The actuator must not be installed underneath the AB-QM valve

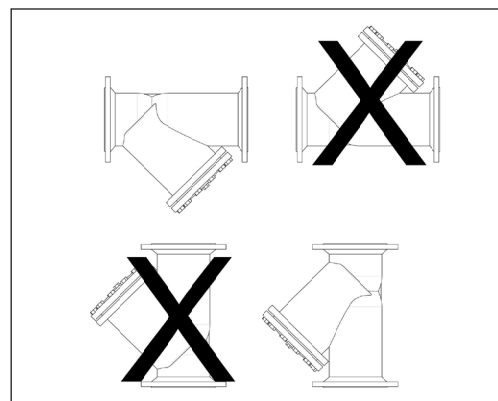

Data sheet

Hero Plant DN15-150

Commissioning

Hero units are self-commissioned and do not require a Danfoss representative to be present. Commissioning procedure is as follows:

- Check all connections for leaks
- Ensure operation of all the isolation valves
- Check the Hero is installed with the flow direction matching the arrows on the AB-QM, and strainer
- Check, and if required, empty the strainer
- Remove the actuator and set the AB-QM to the desired flow rate
- Verify the flow rate using the method described in the datasheet
- Re-attach the actuator

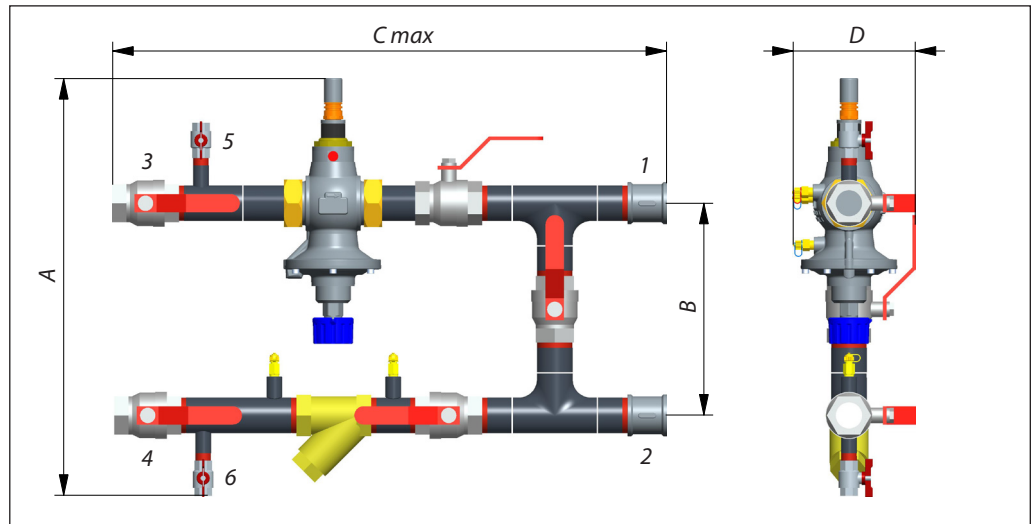
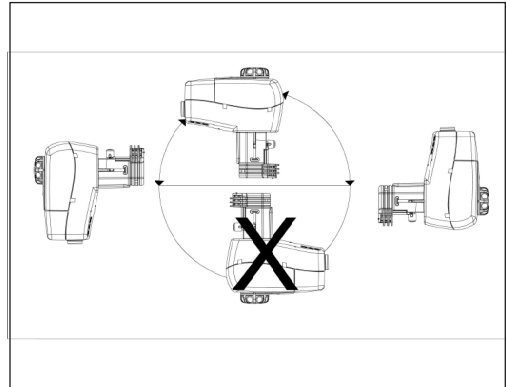

	Size	15	20	25	32	40	50	65	80	100	125	150
Dimensions	A	257	289	333	494	569	596	814	860	971	1163	1233
	B	95	115	147	260	289	310	441	461	509	627	615
	C	345	441	541	707	756	857	988	1068	1170	1324	1442
	D	102	111	120	113	150	169	326	338	397	523	587
Connection	1	1/2" BSP Threaded	3/4" BSP Threaded	1" BSP Threaded	1.1/4" BSP Threaded	1.1/2" BSP Threaded	2" BSP Threaded	2 1/2" Flanged	3" Flanged	4" Flanged	5" Flanged	6" Flanged
	2											
	3											
	4											
	5											
	6											

Danfoss can accept no responsibility for possible errors in catalogues, brochures and other printed material. Danfoss reserves the right to alter its products without notice. This also applies to products already on order provided that such alterations can be made without subsequent changes being necessary in specifications already agreed. All trademarks in this material are property of the respective companies. Danfoss and the Danfoss logotype are trademarks of Danfoss A/S. All rights reserved.