

Danfoss Scroll Compressors SH485

The family is growing **Get more for less** with **"the big blue"**

The unique design of the SH485 offers a compact and innovative 40-ton capacity scroll in the size of a 30-ton scroll. Patented features bring enhanced reliability and performance to HVAC systems. Count on excellent part-load efficiency that helps to meet coming IPLV and SEER regulations and a wide range of manifold configurations to reduce applied costs.

24%

higher part-load
efficiency saves
running costs.





The Danfoss SH family Complete range for optimized commercial applications

Versatile compressors

SH Danfoss scroll compressors have a very wide application envelope. An SH compressor suits varied applications such as rooftops, chillers or process cooling, optimizing the number of items held in reference and inventory.

Consistently reliable

Reliable by design, the Danfoss SH compressors have an integrated non-return valve, which avoids refrigerant migration from the high pressure side. The electronic motor protection prevents from overheating, overloading, phase loss and phase order.

High efficiency, reduced applied and running costs

The performance of air conditioning units depends on their ability to adapt to seasonality, daily ambient temperature variations and to continuously varying load conditions

inside a building. Danfoss SH compressors offer superior efficiency with the new Intermediate Discharge Valve in 40-ton, intermediate cap and a “no contact – no wear” scroll design for reduced friction making a vital difference and lowering running costs. Danfoss optional surface sump heater also enhances the compressor efficiency and decreases the sound level. Furthermore, the possible manifold configurations up to 120 tons in a circuit will also reduce applied and running costs.

Environmentally conscious

Danfoss has removed environmentally harmful substances in scroll compressors. Since 2012, large Danfoss scrolls are RoHS compliant. With Danfoss you can always be sure of unique sustainable solutions without compromising on reliability, endurance or performance.

SH-295 compresses your carbon footprint

The SH295 offers a 25TR cooling capacity with higher energy efficiency for all rooftop and chiller applications.

- The smallest foot print in its size
- 25% lighter compared to standard 25 TR compressors
- 3.25 COP / 11.1 EER





The “big blue” 40 ton-scroll brings you more for less

Ideal for large chillers and roof top units, the SH485 is a compact scroll compressor with several major innovations and unique features. It:

- offers higher part-load efficiency
- improves unit uptime and energy savings
- reduces development and installation costs
- enhances reliability and increases lifetime
- provides low sound levels and lower maintenance costs to end-users

Higher part-load efficiency with better energy standard compliance...

The **Intermediate Discharge Valve (IDV)** introduced in the Danfoss 40 ton compressor adapts energy consumption to the varying load and pressure conditions in the system. As a result, the SH485 offers up to 24% higher part-load efficiency compared to a standard system. The superior full load and part-load performance helps OEM systems meet the coming stringent part-load energy regulations – IPLV, IEER, SEER – and leads to significant energy and cost savings in the overall lifetime of the units.



... and less stress on components

The quick adaptive capability of the IDV helps lower the mechanical stress on the scroll components, enhancing overall reliability of the compressor and improving the OEM's system uptime. In short, compressors with IDV are far more efficient than those without.

Get more

reliability and efficiency with the 40-ton's unique features for less applied costs.



Further unique compressor benefits with SH485

The SH485 compressor comes with a number of unique features that offer enhanced reliability and higher uptime.

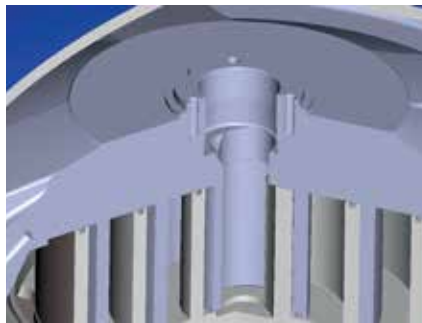

Built-in PTC is positioned inside the compressor to sense the discharge gas temperature. The PTC reacts quickly when operating conditions are beyond safety limits. It protects the compressor by sending a signal to the electronic motor protections system. As a result the innovative PTC saves service costs and increases the HVAC unit life time.



The organ pipe significantly improves system reliability by retaining oil in non-operating compressors under part-load operation in manifold configurations. Additionally, oil retention in the compressor improves the heat transfer in the evaporator, boosting overall system efficiency.



Wide operating envelope

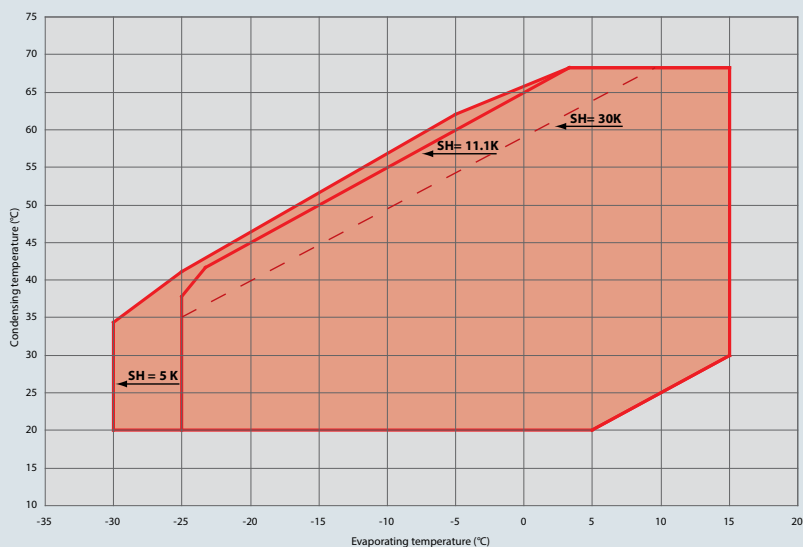

The wide operating envelope of large SH Danfoss scrolls fits more applications and helps reduce the condenser size to save applied costs.

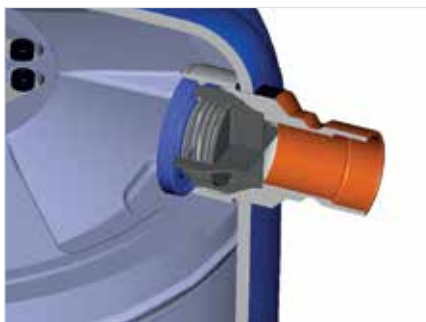

X Non-Return Valve (XNRV) placed inside the discharge connector reduces refrigerant migration from high pressure to low pressure side after the compressor shutdown, improving compressor reliability with no additional costs on assembly for the OEM or installer.

Danfoss optional surface sump heater: for higher efficiency and noise reduction

The Danfoss surface sump heater is an optional patented heater which suits all SH models and that is designed to:

- improve the sound level with the insulation pad at the bottom
- reduce power input per heater by up to 38% compared to a standard belt type crankcase heater
- reduce sensitivity to ambient air temperature and wind speed surrounding the compressor
- enhance heat transfer with larger surface area and wider contact with the compressor
- improve system efficiency through uniform heating and lower power consumption.



Unparalleled manifold compressor performance

Today, almost 90% of all commercial scroll air conditioning systems use manifold compressors. Compressors in manifold configurations offer:

- flexibility in staging
- higher part-load efficiency
- improved uptime
- reduced applied costs
- lower sound levels

Mastering the manifold designs over the years, Danfoss addresses the complex challenges that our customers face in extending their system capacities when using multiple scroll compressors. Our safe compressor

operations and static and dynamic manifold piping design offers superior performance with even and uneven configurations under both full-load and part-load conditions.

Each of the large SH Danfoss compressors is equipped with an oil equalization connector and oil sight glass rendering it ready for use in single, tandem or trio configuration with no additional cost.

The Danfoss manifold configurations offer wider capacity modulation. For example, a system with six compressors manifolded in two circuits offers a

capacity modulation from 17% to 100% ensuring excellent part-load efficiency. It simply provides superior uptime and efficiency: even if one compressor fails, the other will be able to operate.

Mechanically the sound level is also significantly lower than alternative compression technologies in larger capacities. The sound level of a tandem configuration is higher by just 3 dB(A) over the single scroll compressor, which is significantly lower compared to an equivalent capacity compressor of other technology.

17-100%

capacity modulation
with six compressors
in the system.



Possible manifold configurations with SH range

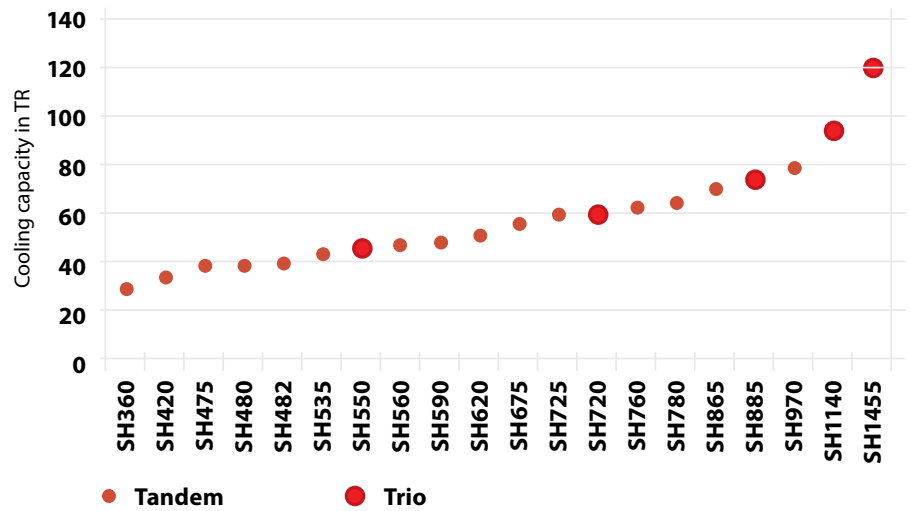

	Composition	Cooling capacity - R410A	
		60 Hz - TR ARI	50 Hz - kW En12900
SH360	SH180 + SH180	30	78 400
SH420	SH240 + SH180	35	91 910
SH475	SH180 + SH295	40	103 720
SH482	SH240 + SH240	40	105 420
SH535	SH240 + SH295	45	117 230
SH550	3 x SH180	45	116 060
SH560	SH380 + SH180	47	118 870
SH590	SH295 + SH295	49	129 040
SH620	SH240 + SH380	52	132 380
SH675	SH295 + SH380	56	144 190
SH720	3 X SH240	60	156 050
SH725	SH240 + SH485	60	155 210
SH760	SH380 + SH380	63	159 340
SH780	SH295 + SH485	65	167 020
SH865	SH380 + SH485	72	182 170
SH885	3 x SH295	74	191 020
SH970	SH485 + SH485	81	204 990
SH1140	3 x SH380	95	235 870
SH1455	3 x SH485	121	303 460

Rating conditions - R410A

	50 Hz	60 Hz
Frequency:	50 Hz	60 Hz
Evaporating temp.:	5°C	7.2°C / 42°F
Condensing temp.:	50°C	54.4°C / 130°F
Super heat:	10K	11.1K / 20°F
Sub-cooling:	0K	8.3K / 15°F

Danfoss large scroll series performance

Model	Nominal cooling capacity	50 Hz, EN12900 ratings				50 Hz, ARI ratings			
		Cooling capacity		Efficiency		Cooling Capacity		Efficiency	
		TR - 60 Hz	W	Btu/h	COP in W/W	EER in Btu.h/W	W	Btu/h	COP in W/W
SH180	15	39 556	134 965	3.14	10.71	44 500	151 800	3.21	10.95
SH240	20	53 200	181 400	3.16	10.78	60 400	206 300	3.22	11.00
SH295	25	65 100	222 200	3.17	10.82	73 200	249 800	3.25	11.10
SH380	30	80 400	274 300	3.13	10.68	90 400	308 700	3.21	10.95
SH485	40	103 400	352 900	3.17	10.8	116 400	397 100	3.25	11.14

Model	Nominal cooling capacity	60 Hz, ARI ratings				Net weight	
		Cooling Capacity		Efficiency			
		TR - 60 Hz	W	Btu/h	COP in W/W	EER in Btu.h/W	kg
SH180	15	54 300	185 300	3.27	11.15	108.0	238.1
SH240	20	73 500	251 000	3.27	11.15	108.0	238.1
SH295	25	88 500	302 000	3.25	11.10	111.0	274.7
SH380	30	109 600	374 300	3.22	11.00	159.0	350.5
SH485	40	140 600	479 600	3.25	11.10	175.0	385.8



SH180



SH240



SH295



SH380



SH485

Only two compressor sizes for a cooling capacity ranging from 15 to 40 tons