

Type	Value
Max Weight	23.5 kg / 51.8 lb
IP Class	IP20
Nema Class	CHASSIS

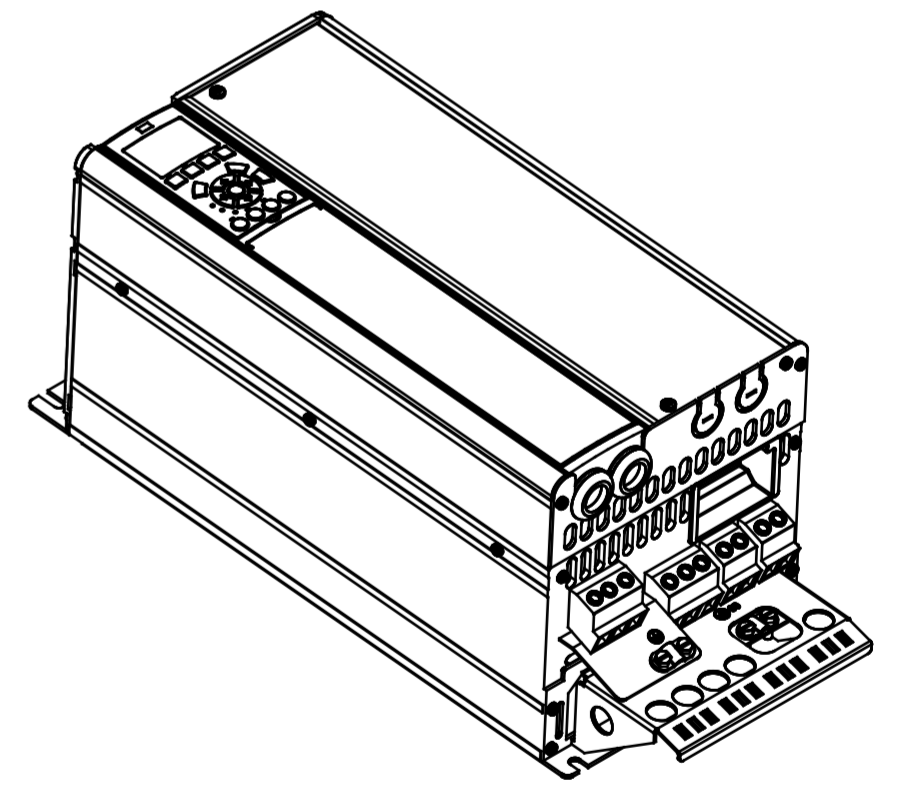

SCALE 1:5

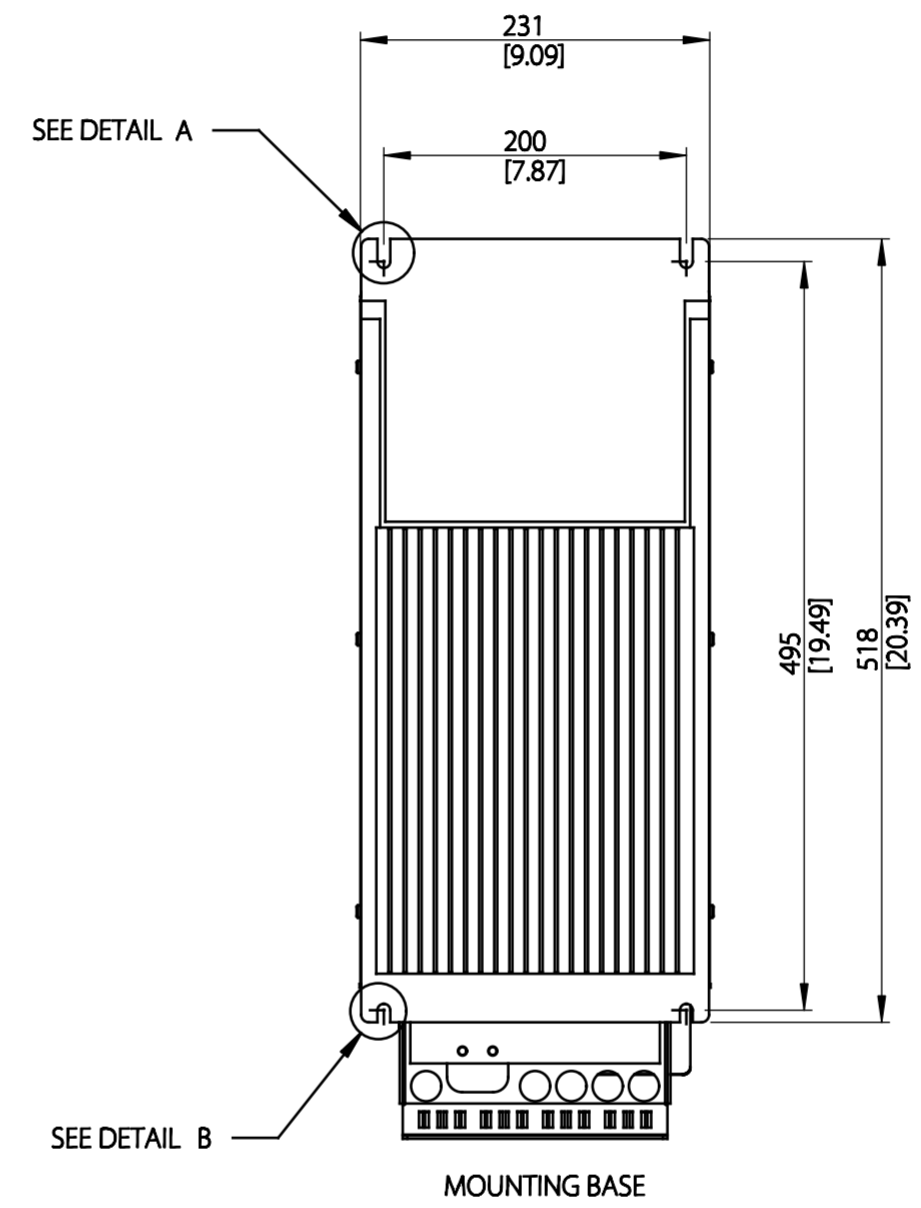
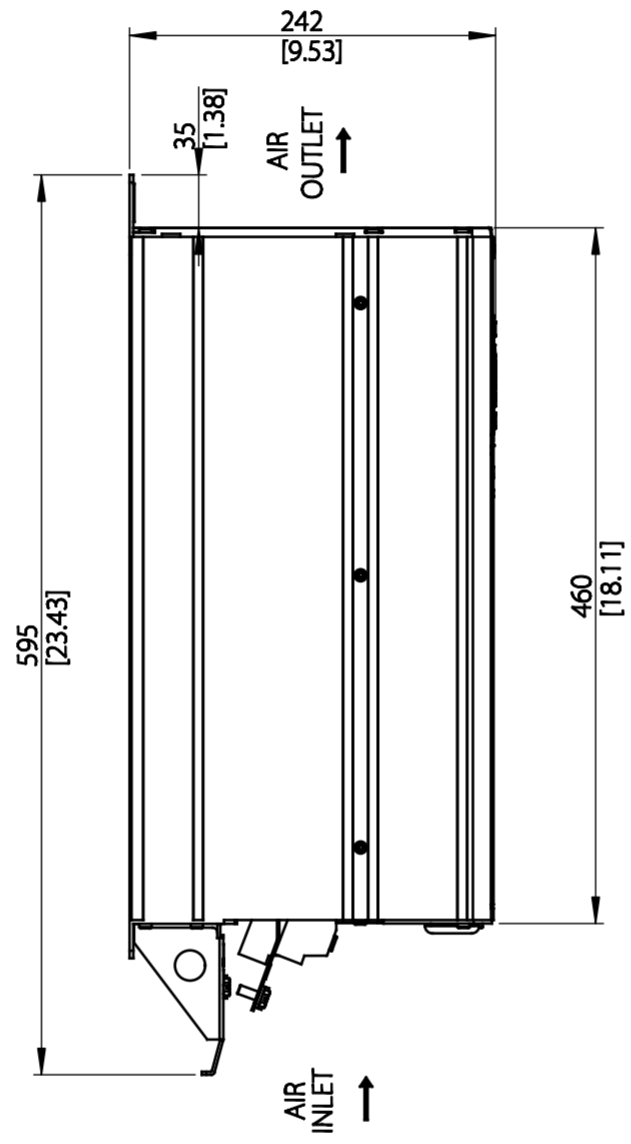
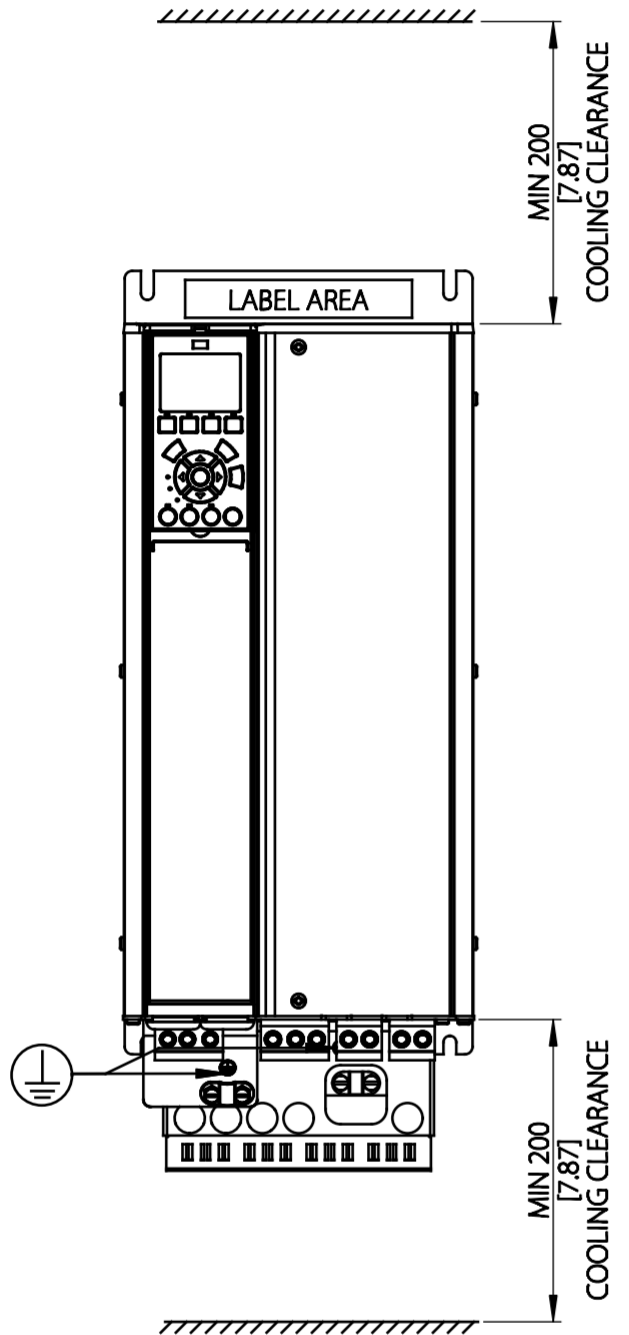
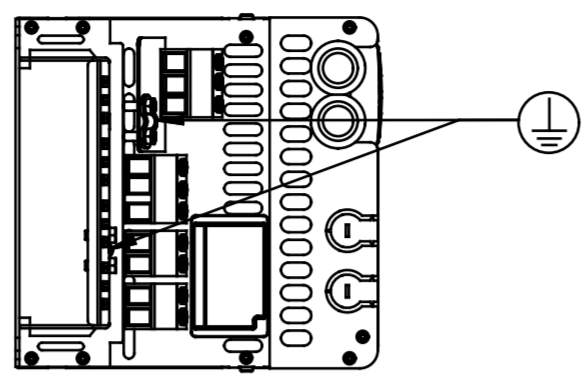
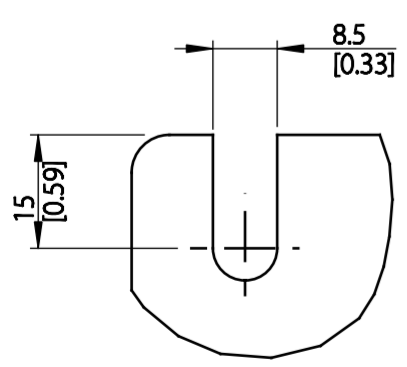

DETAIL A
SCALE 1:1

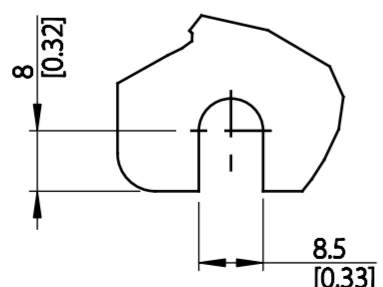

DETAIL B
SCALE 1:1

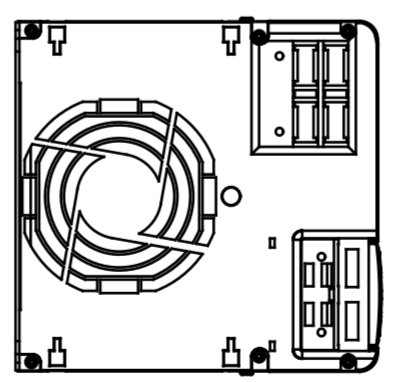

THIS DRAWING SHOWS THE MOST COMMON VERSION OF THIS PRODUCT VARIANT.
SMALL DIFFERENCES MAY OCCUR DEPENDING ON THE FINAL PRODUCT CONFIGURATION.

CENTER OF GRAVITY:
FOR REFERENCE ONLY, THE PRODUCT CONFIGURATION MAY INFLUENCE THE CG IN ALL THREE AXES.

UNLESS OTHERWISE SPECIFIED THE TOLERANCE IS ±1MM [0.4 INCH]. ALL DIMENSIONS ARE IN MILLIMETERS [INCH]			FIRST ANGLE PROJECTION	SCALE	DRAWING SIZE	MATERIAL
				1:5	A2	FINISH
			DESCRIPTION			
			MCAD B4 IP20			
CHANGED			DRAWING NUMBER			
DESIGNED	DANFOSS	19-04-16	MCAD-B4-IP20			
CHECKED			REV			
			001			
			SHEET			
			1 OF 1			
PROPERTY OF DANFOSS A/S NORDBOG, DENMARK. TWO OR THREE DIMENSIONAL REPRODUCTION OF CONTENTS TO BE AUTHORIZED BY DANFOSS A/S.			MODEL			
			MCAD-B4-IP20			

