

DETAIL A
SCALE 2:1

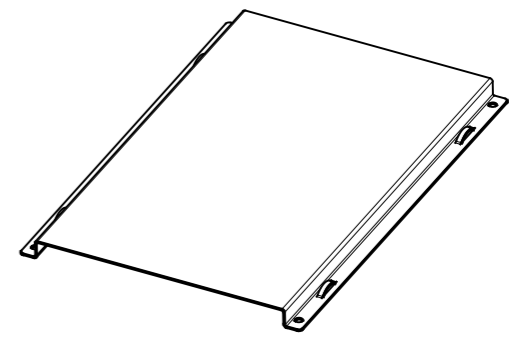

SCALE 1:5



- ⑯ General bending radius: 1 mm
- ⑰ Corner rounds not specified: $R2.5 \pm 0.5$
- ⑱ Part must be washed and degreased
- ⑲ Material specification:
1.0mm Sheet acc. to EN 10346-DX51D+AZ150-N-A-C
- ⑳ Not specified dimensions according to unfolded part

Projection 	Scale / Paper size 1:2 / A3		Matr./Spec. See note
Last revised by H. Jessen			Date 2013.05.21
DANFOSS DRIVES A/S		Designation Backplate B4	Part no. 130B3667
Confidential: Property of Danfoss Drives A/S. Not to be handed over to, copied or used by third party. Two- or three dimensional reproduction of contents to be authorized by Danfoss Drives A/S.			Sh. 1 of 2
PDM controlled drawing. - Hard copy not valid without frozen date in ID stamp.			Rev. 002

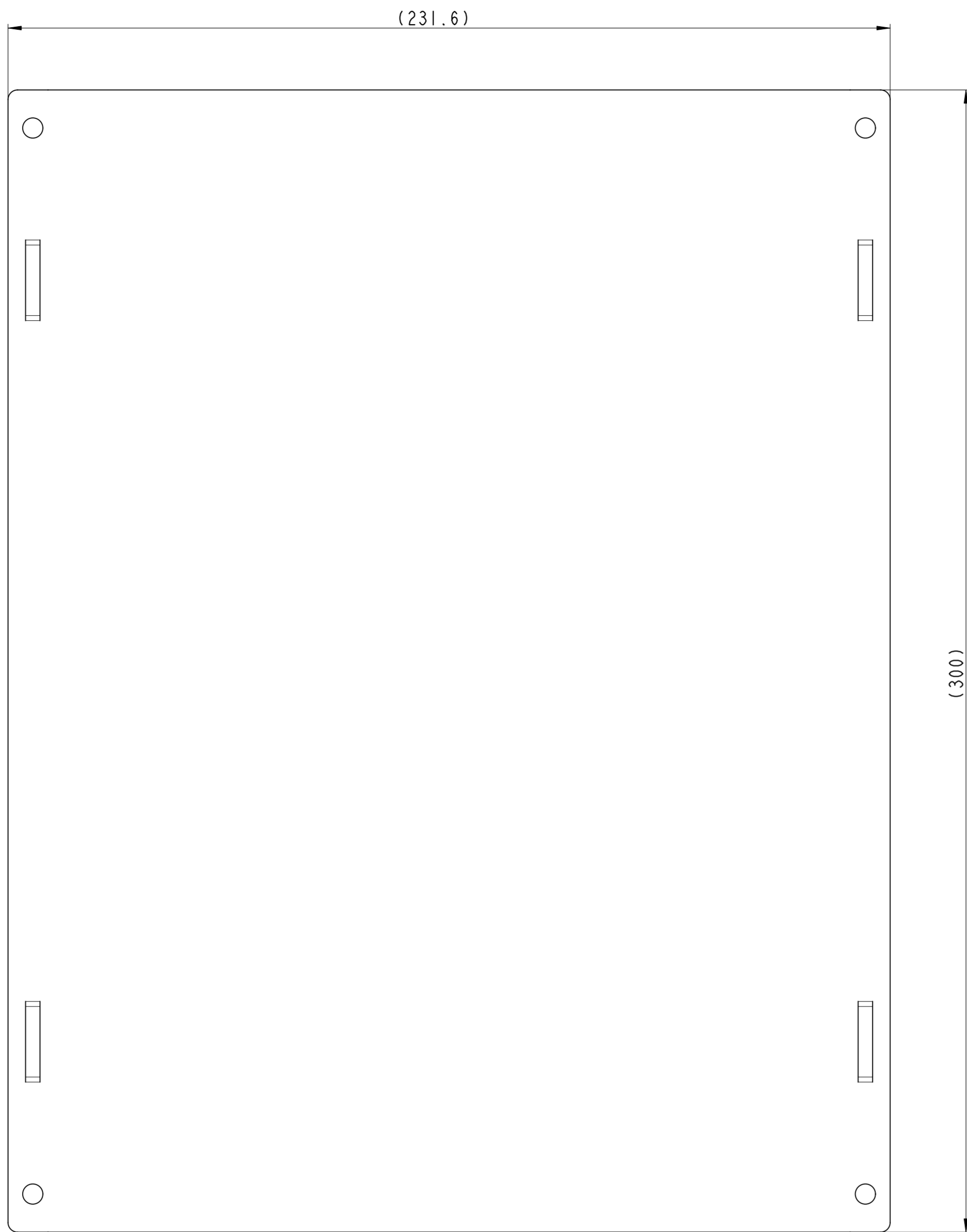
Model: 130B3667.PART

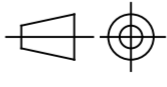

For internal use: Y bending factor = 0.58

	Scale / Paper size 1:2 / A2		Matr. /Spec. See note
Last revised by H. Jessen	Date 2013.05.21		Danfoss standard
DANFOSS DRIVES A/S			Designation Backplate B4
Confidential: Property of Danfoss Drives A/S. Not to be handed over to, copied or used by third party. Two- or three dimensional reproduction of contents to be authorized by Danfoss Drives A/S.			Part no 130B3667
PDM controlled drawing. - Hard copy not valid without frozen date in ID stamp.			Rev. 002

Model: 130B3667.PART

2 of 2