

Type	Value
Max Weight	4.9 kg / 10.8 lb
IP Class	IP20 C
Nema Class	CHASSIS

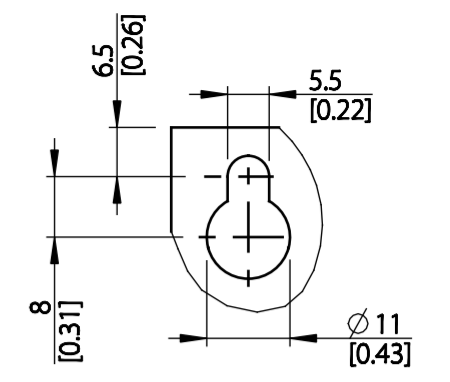

DETAIL A
SCALE 1:1

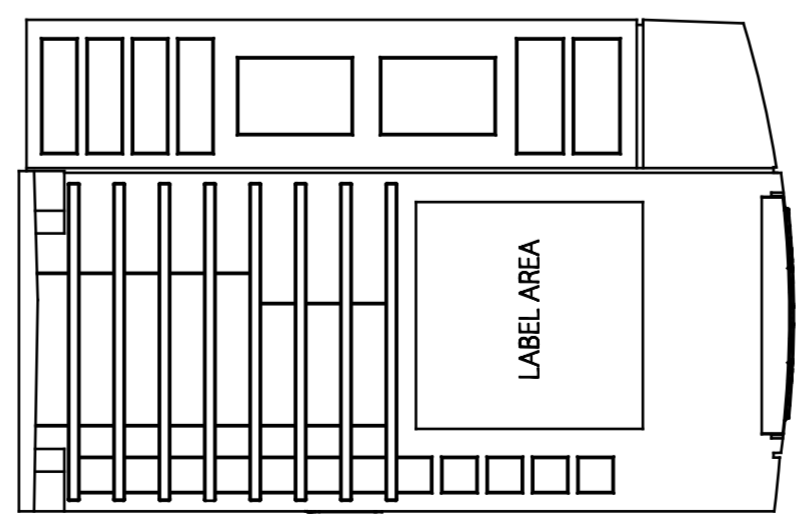
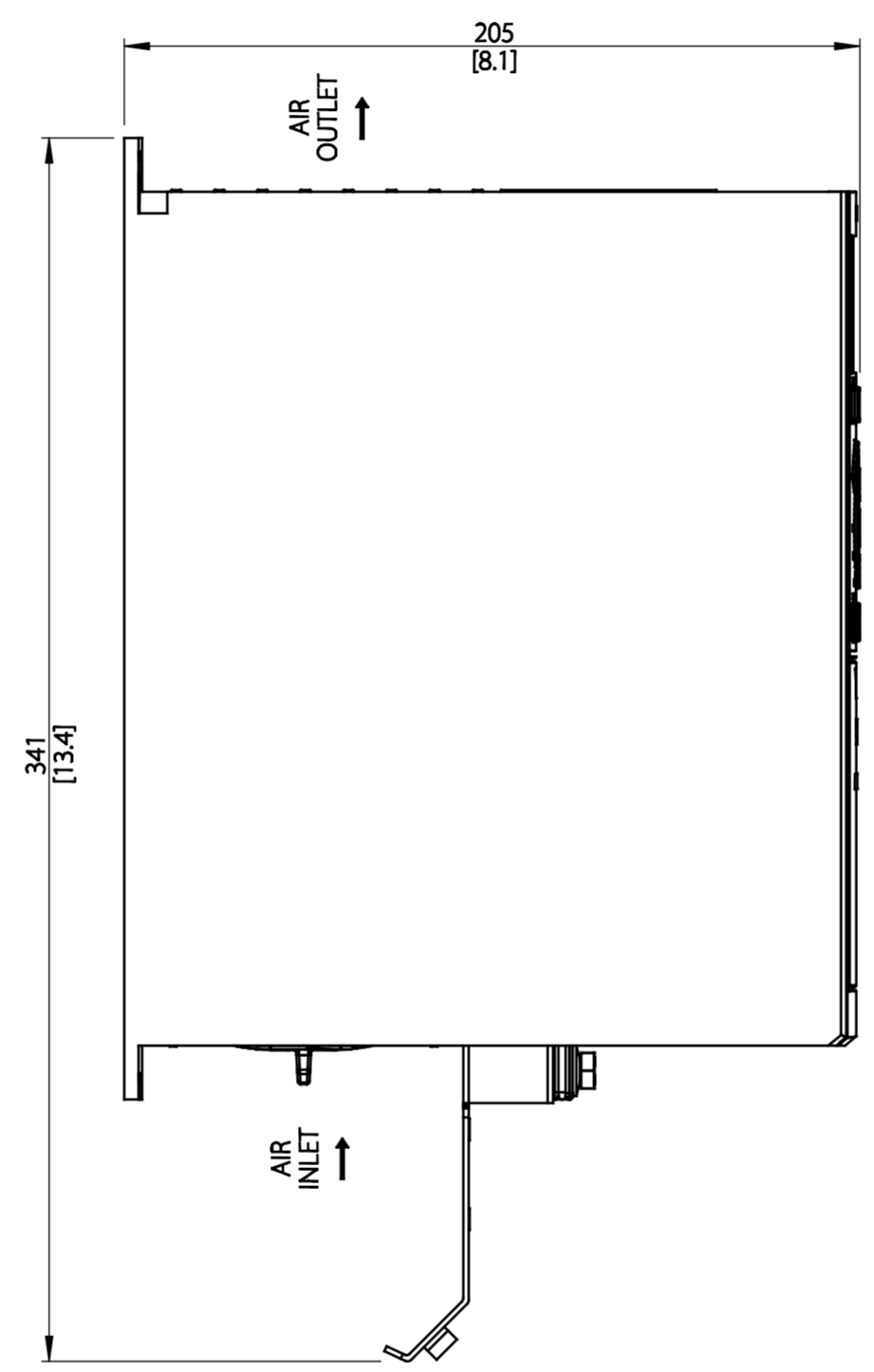
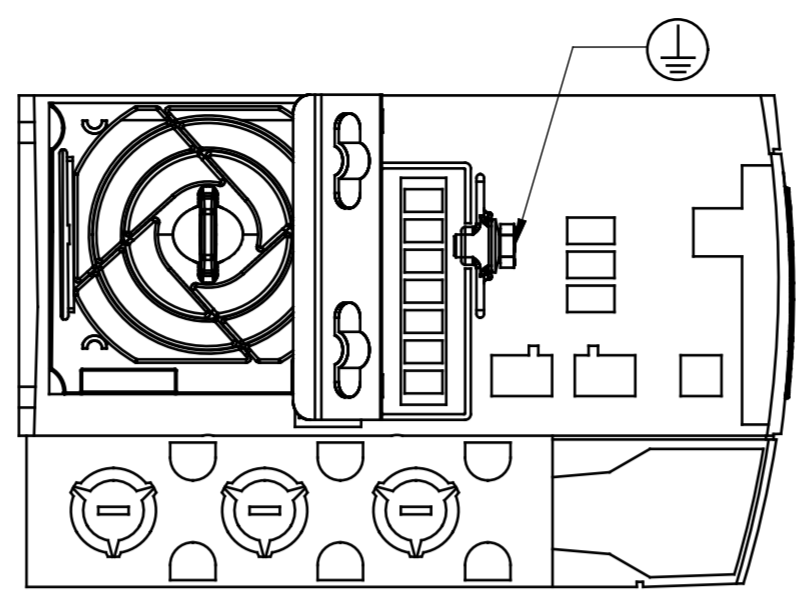
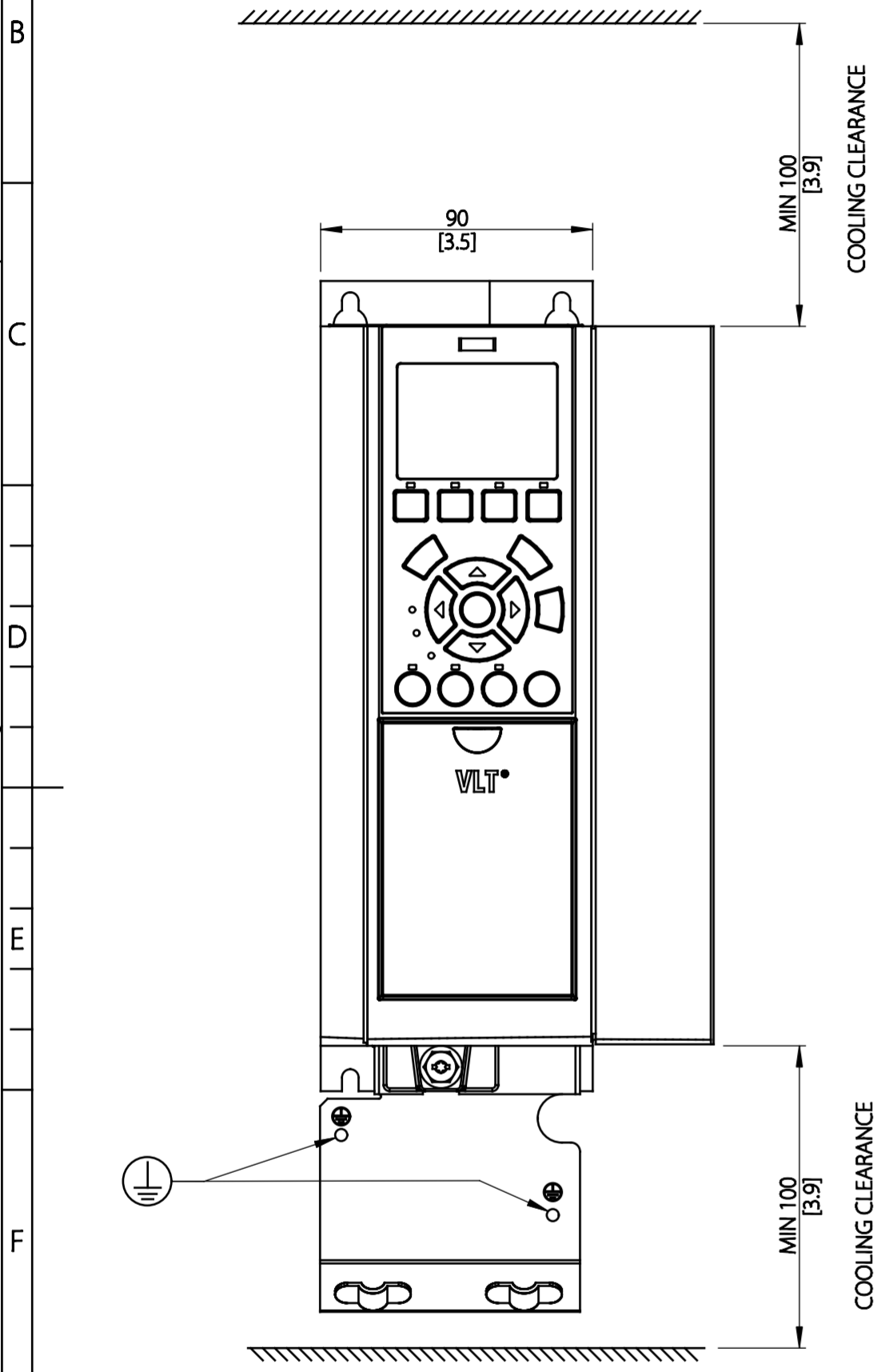
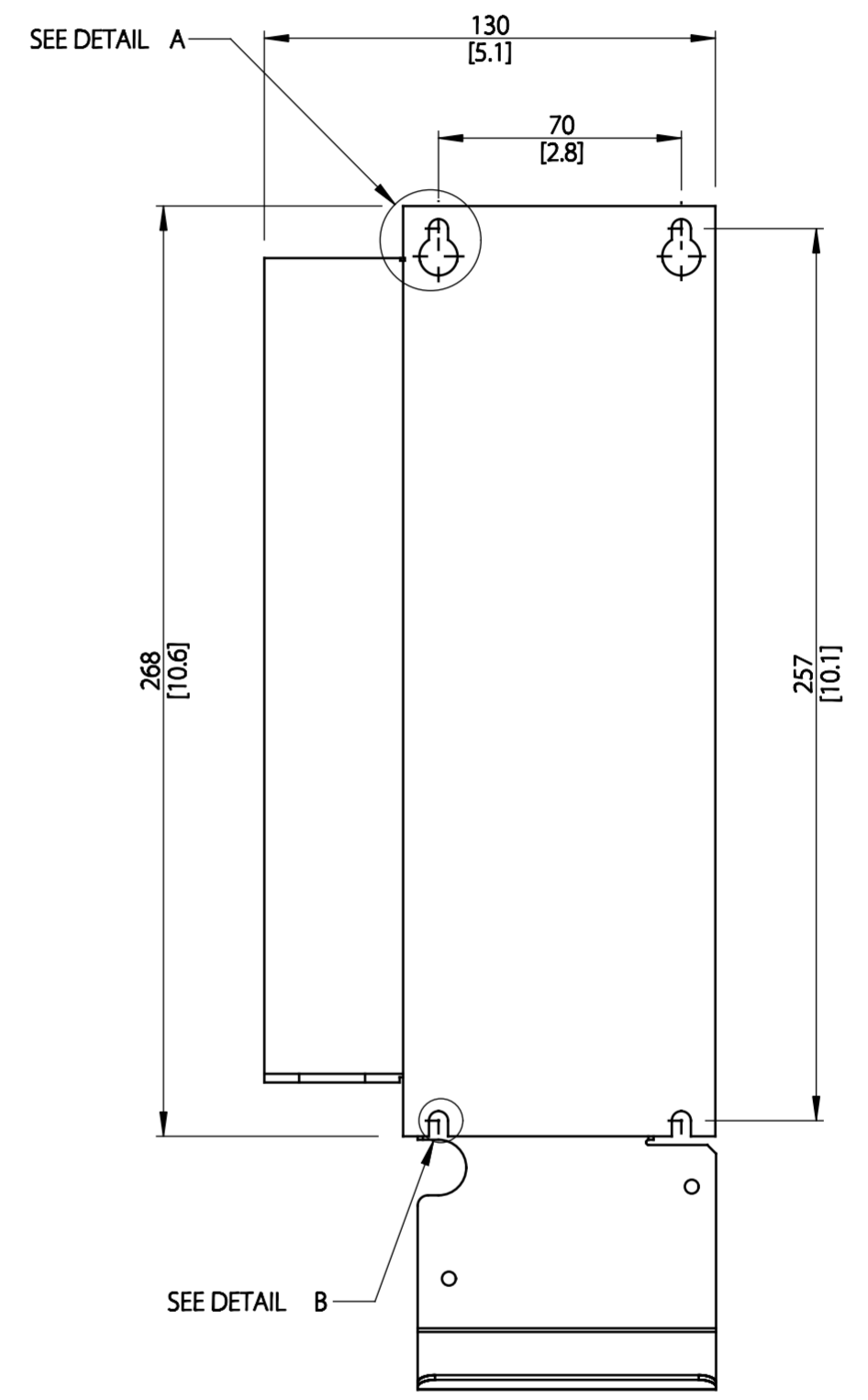

MOUNTING BASE

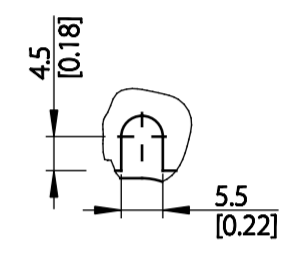

DETAIL B
SCALE 1:1

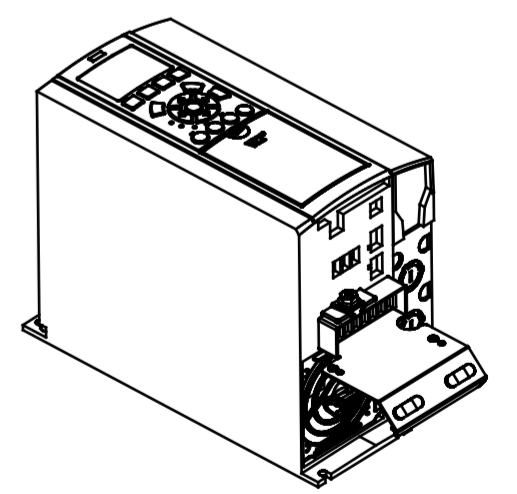

THIS DRAWING SHOWS THE MOST COMMON VERSION OF THIS PRODUCT VARIANT.
SMALL DIFFERENCES MAY OCCUR DEPENDING ON THE FINAL PRODUCT CONFIGURATION.

● CENTER OF GRAVITY:
FOR REFERENCE ONLY, THE PRODUCT CONFIGURATION MAY INFLUENCE THE CG IN ALL THREE AXES.

UNLESS OTHERWISE SPECIFIED THE TOLERANCE IS ±1MM [0.4 INCH]. ALL DIMENSIONS ARE IN MILLIMETERS [INCH]			FIRST ANGLE PROJECTION	SCALE 1:2	DRAWING SIZE A2	MATERIAL
						FINISH
			DESCRIPTION			
			MCAD A2 IP20 C			
CHANGED			DRAWING NUMBER MCAD-A2-IP20-C			
DESIGNED	DANFOSS	27-11-2015	REV 001			
CHECKED			MODEL MCAD-A2-IP20-C			
PROPERTY OF DANFOSS A/S NORDBOG, DENMARK. TWO OR THREE DIMENSIONAL REPRODUCTION OF CONTENTS TO BE AUTHORIZED BY DANFOSS A/S.			SHEET 1 OF 1			