

X4

X1 Mains 35mm²(4Nm)
 X2 Drive 35mm²(4Nm)
 X3/X4 Capacitor disconnect 16mm²(3,5Nm)
 A/B Temperature 2,5mm²(0,8Nm)

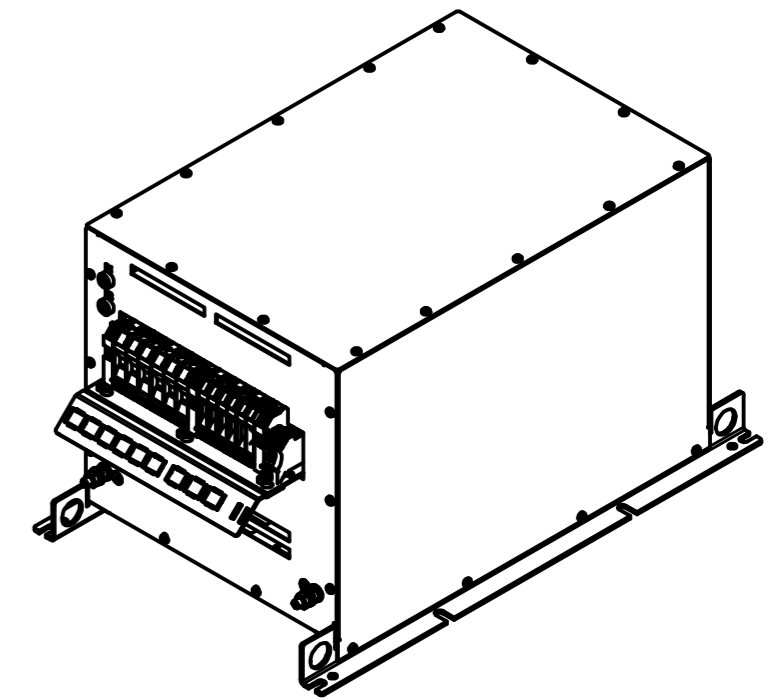
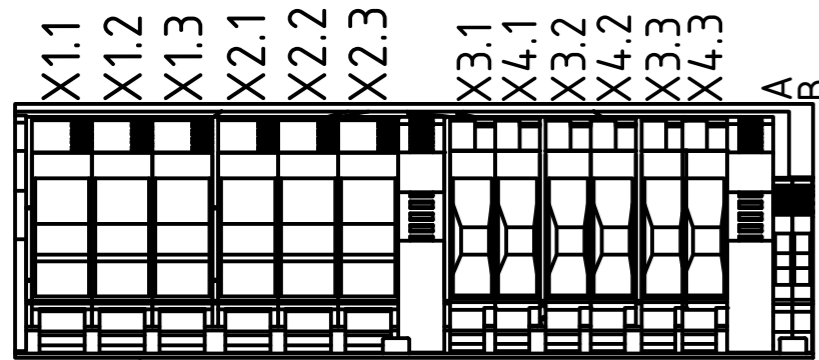
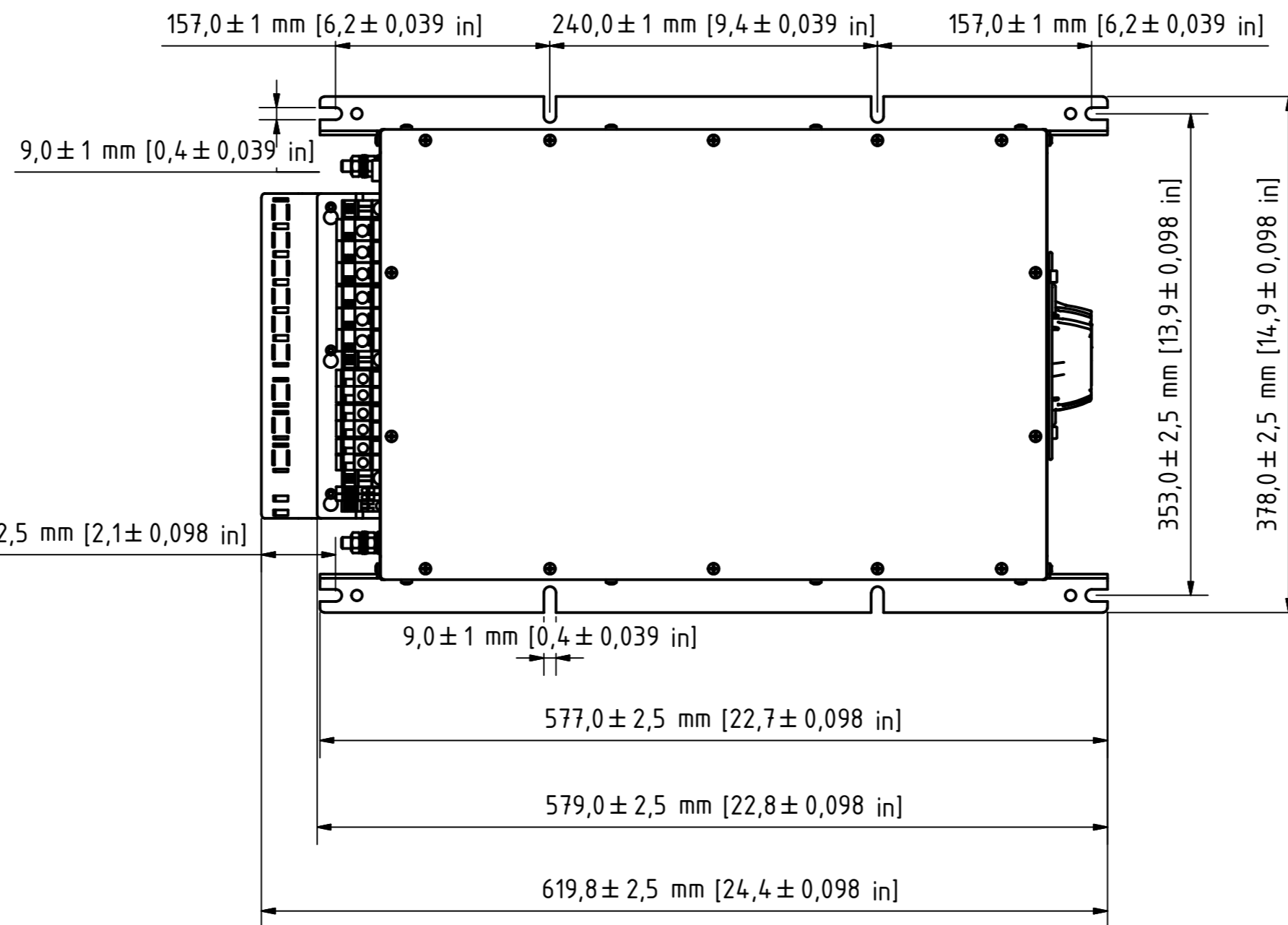
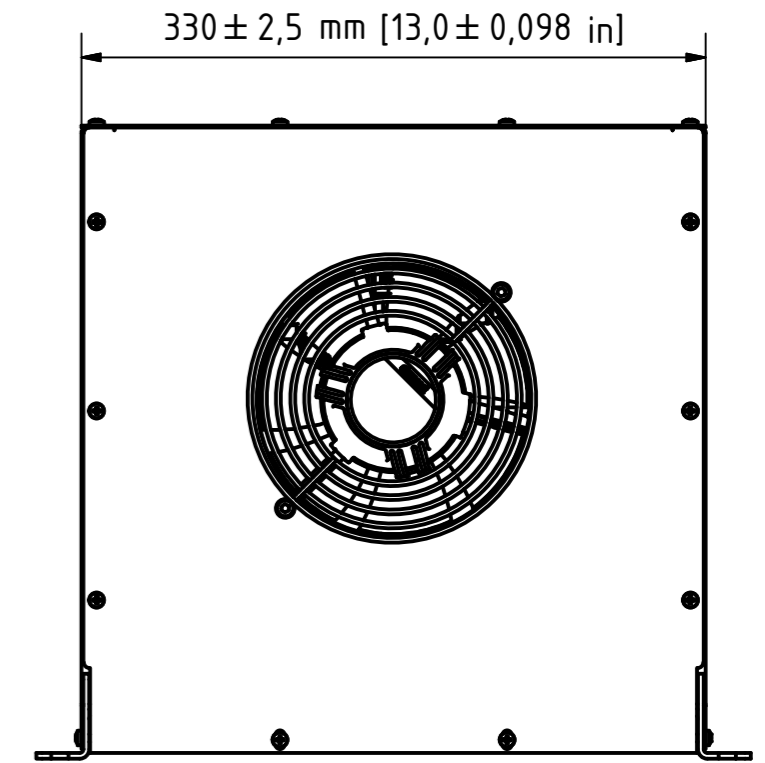
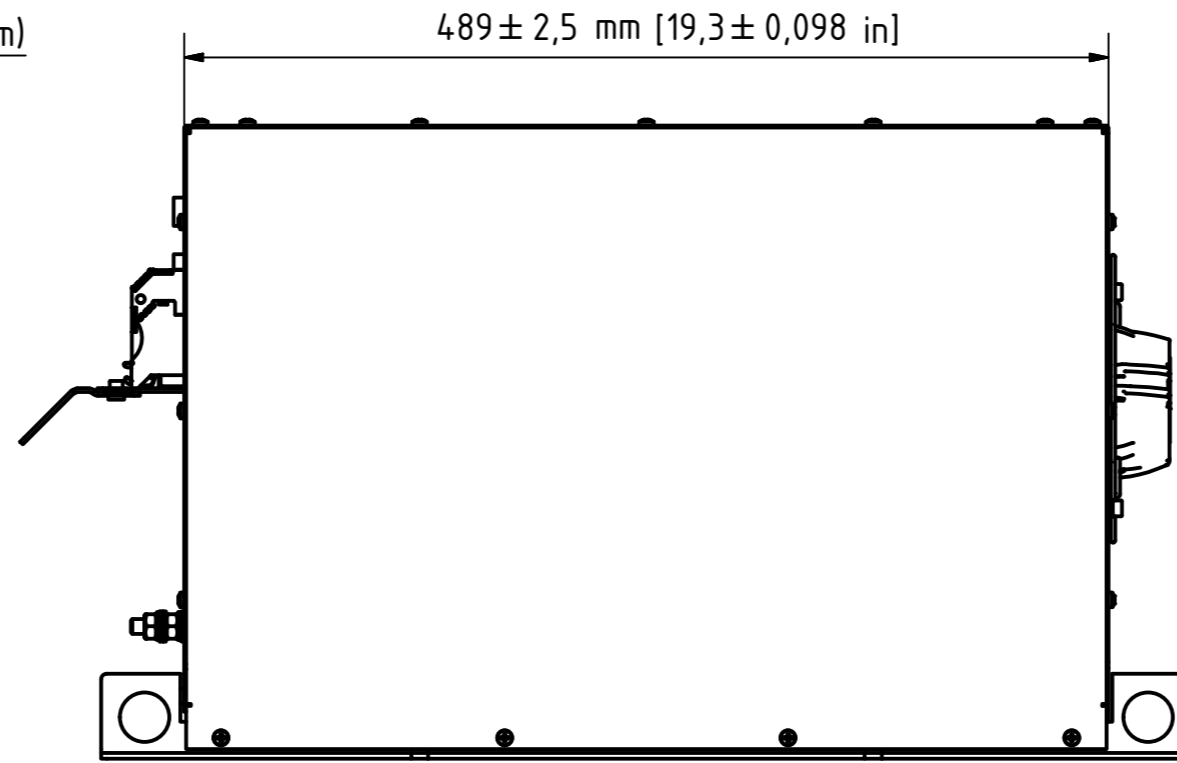
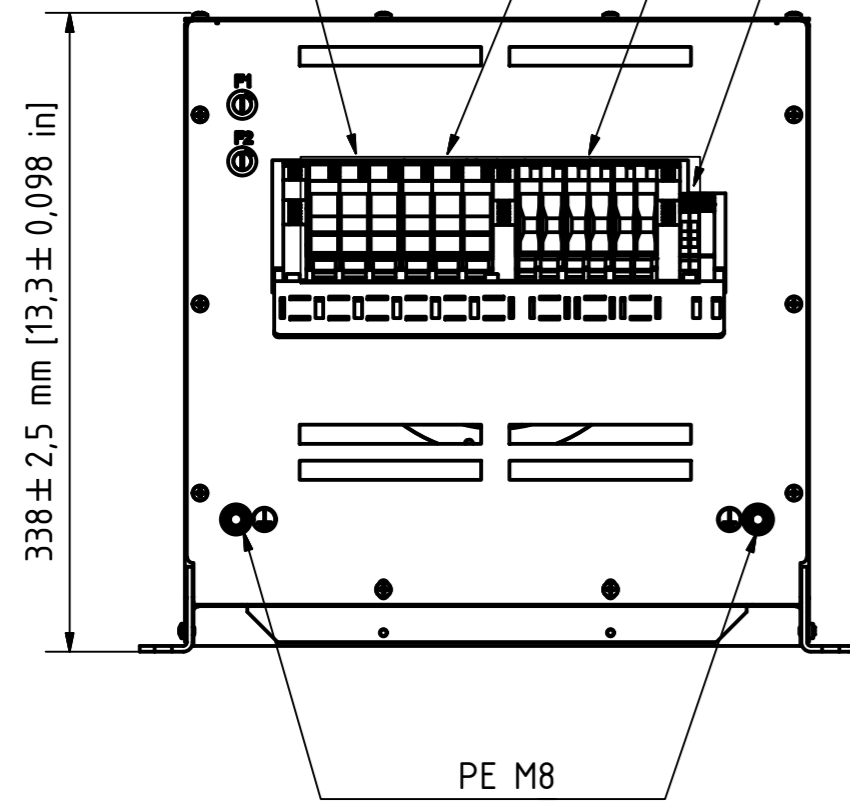

				DATE	Name	Designation	
				Drawn 20.03.2014	CM	X4 IP20 with internal fan 2	
				Reviewed 19.08.2014	MK		
				Standard	DIN 2768-1 V		
				Scale drawing	1:1		
				Print scale	Approx. 1:5	Drawing Number	
R	Terminals	14.03.16	1			X4 C IP20 if2	
R	Dimensions	20.08.14	1			1	
Status	Modifications	DATE	Name			A2	