

Reproduction, use or disclosure to third party is forbidden. All rights reserved.

1 2 3 4 5 6 7 8

*) To be cold insulated, e.g. with polyethylene, if the temperature of the liquid in the secondary circuit is lower than the ambient temperature and the relative humidity is high.

Code	Pcs.	Material	Note.	Name	Nominal pressure
PU11	1	AISI304 / 316	Vacon delivery	Pump 1 1/2", Grundfos CHI 8-25, 3x400V /50 Hz, 1730W, 3.4A	PN10
HX11	1	AISI316 / Cu-brazed	Vacon delivery	Plate heatexchanger 1" / 1/2"	PN32
HXA11	1	Cu-coil / Al-frame	Vacon delivery (option)	Water/Air heatexchanger 3/4"	-
EV11	1	AISI304 / Butyl	Vacon delivery	Pressure vessel 3/4", pre-pressured to 100kPa, cap. 5 litre Connection stainless steel, inside vessel epoxy coating, butyl diaphragm	PN10
MF21..22	2	-	Vacon delivery (option)	Y-Strainer	-
AD11	1	AISI304 / 316	Vacon delivery	Automatic de-airing unit 3/8"	PN16
FTSA11	1	AISI304 / 316	Vacon delivery	Flowswitch 1/2", with analog temperature outlet	PN60
PT11	1	AISI304 / 316	Vacon delivery	Pressure transmitter 1/4", 0-10 bar	PN20
PI11	1	AISI304 / 316	Vacon delivery	Pressure indicator 1/4", 0-10 bar	PN20
TI21	1	-	Vacon delivery (option)	Temperature indicator 1/2", 0-60°C	-
LS11	1	-	Vacon delivery	Leakage switch 24V AC/DC, 70mA	-
V120	1	AISI304 / 316	Vacon delivery	Safety valve 1/2", reliefpressure 6bar Body bronze, nozzle and disc stainless steel	PN25
V130	1	EN-JS1030, CW602N	Vacon delivery	Regulating valve DN20 + actuator (FV11)	PN16
V140	1	PVC-C	Vacon delivery	Ballvalve DN25	PN16
V150	1	AISI304 / 316	Vacon delivery	Non-return valve 1/2"	PN40
V160	1	AISI304 / 316	Vacon delivery	Ballvalve 3-way 3/4", threaded	PN64
V161..63	3	AISI304 / 316	Vacon delivery	Ballvalve 1/2", threaded	PN64
V170	1	AISI304 / 316	Vacon delivery (option)	Ballvalve 1/2"	-
V180	1	Brass	Vacon delivery (option)	Balancing valve 1/2"	-
V201..05	5	-	Vacon delivery (option)	Ballvalve	-
V301..02	2	AISI304 / 316	Projects specific delivery	Ballvalve 1/2", threaded	-
V31x..	-	AISI304 / 316	Projects specific delivery	Ballvalve 1/2", threaded	-
NXP0009 5	1	-	Vacon delivery	Frequency converter, NXP 0009 5A5H1 SSS A1A2B500C5	-

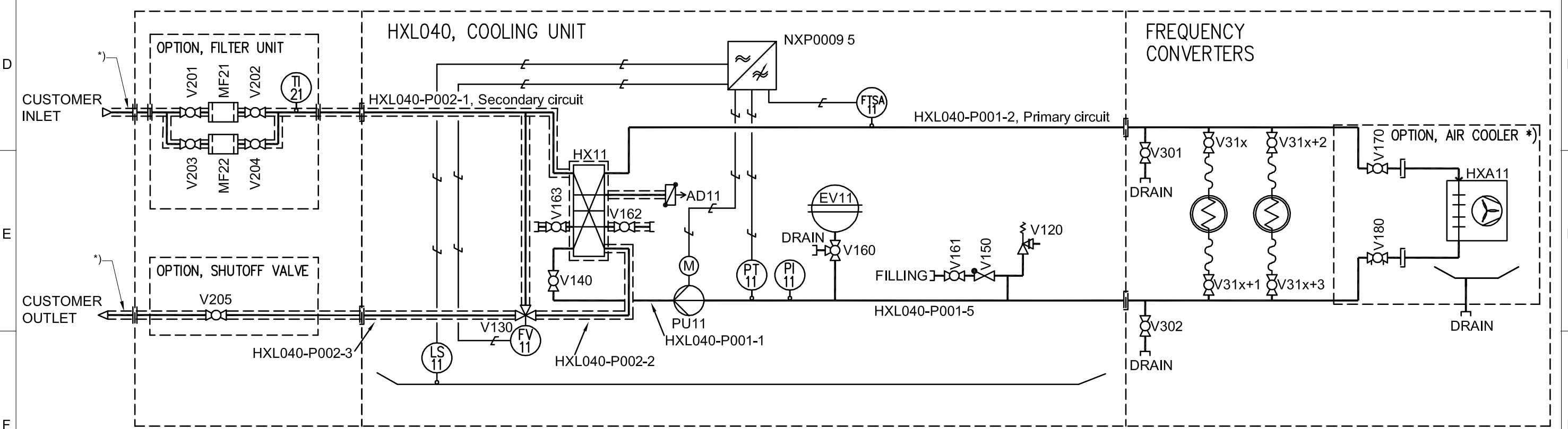

e	26.06.2007	A-M. Haka	J-P. Sampola	Nominal pressures added, P&ID only for PVC	c	09.09.2005	A-M. Haka	J-P. Sampola	Insulate added in secondary circuit
d	11.10.2006	U. Kähkölä	J-P. Sampola	FC and control signals added	b	25.05.2005	A-M. Haka	J-P. Sampola	EV11 capacity changed, HXA11 place changed
REV.	DATE	MADE	APPR	DESCRIPTION	a	09.05.2005	M.Forsén	J-P. Sampola	V160 changed to 3-way valve

Vacon	Project	STD HX-unit	Title	Prepared		M.Forsén 25.10.2004	DCC	&	Object	=
	Customer	-	HXL040	Checked		K.Hofman 25.10.2004	Based on	VL39-5013-01	Loc.	+
	Doc. no.		PVC-C Piping	Approved		J-P.Sampola 25.10.2004	Proj. no	-	Revision	e
	Cust. ref.		P&ID	Vacon Oyj			Doc. no.	VL39-5010-01	Sheet	1/1
										Cont.