

1. MAX AIRFLOW (BACKCHANNEL) - 14 M³/MIN (500 CFM)
2. MAX AIRFLOW (CABINET) - 3.4 M³/MIN (120 CFM)
3. MAX WEIGHT = 125 KG (275 LBS)
4. CENTER OF GRAVITY:
APPROXIMATE LOCATION ONLY, LOCATION MAY VARY BASED ON POWER RATING AND OPTIONS ORDERED.

Ⓞ CRITICAL CHARACTERISTICS
 ▽ KEY CHARACTERISTICS
 ○ INSPECTION
 MUST COMPLY TO ROHS DIRECTIVE 2011/65/EU

INTERPRET DIM. & TOL. PER ASME Y14.5M-1994 ALL DIMENSIONS ARE IN MILLIMETERS TOLERANCES UNLESS OTHERWISE SPECIFIED .X±0.8 .XX±0.50 ≤ ±1.0		THIRD ANGLE PROJECTION 	SCALE 0.150	SIZE A2	MATERIAL N/A
— PDM CONTROLLED DRAWING — NOT VALID WITHOUT FROZEN DATE IN ID STAMP				FINISH N/A	
CHANGED	DESIGNED BC			CHECKED 03/15/19	DESCRIPTION INSTALLATION DRAWING, J9, IP20/CHASSIS
CONFIDENTIAL: PROPERTY OF DANFOSS A/S NORDBORG, DENMARK. NOT TO BE HANDED OVER TO BE COPIED OR BE USED BY A THIRD PARTY. TWO OR THREE DIMENSIONAL REPRODUCTION OF CONTENTS TO BE AUTHORIZED BY DANFOSS A/S.				DRAWING NUMBER 177R0695	REV 001
				MODEL P454_D2_PRODUCTION	SHEET 1 OF 3

SECTION A-A
MAINS TERMINALS

SECTION B-B
MOTOR TERMINALS

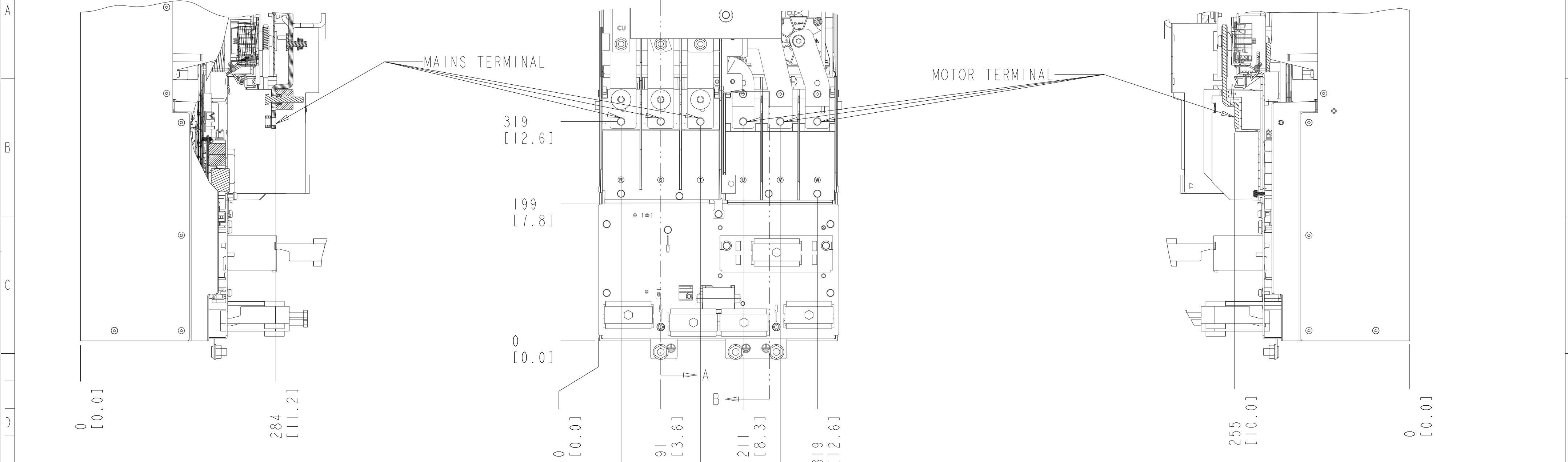

EARTHING / GROUNDING CONNECTIONS

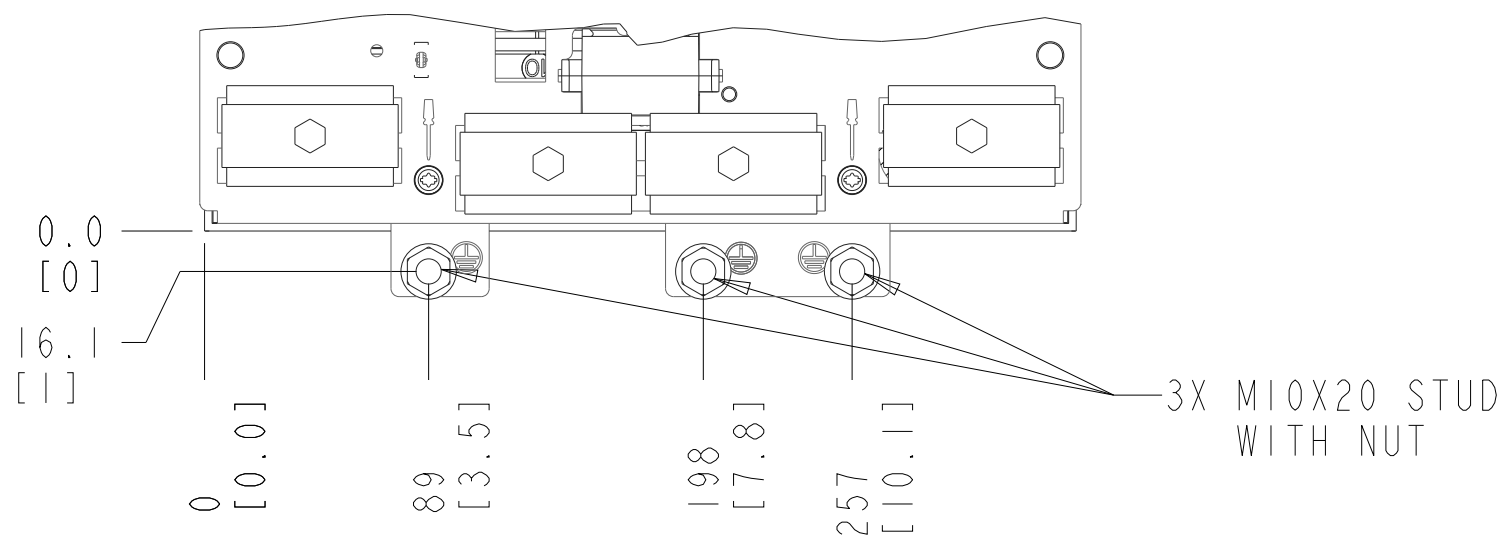

3X M10X20 STUD WITH NUT

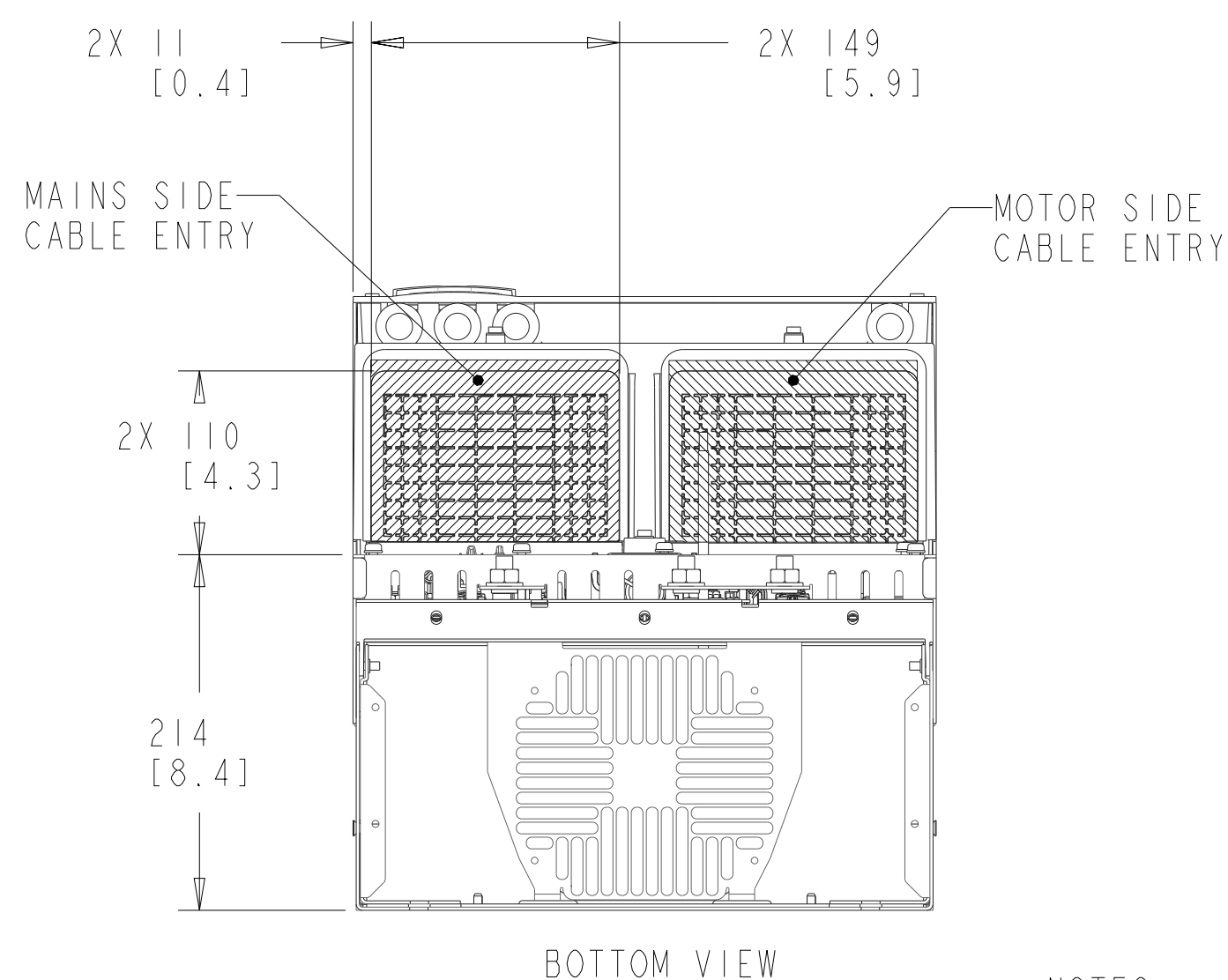

BOTTOM VIEW

TOP VIEW

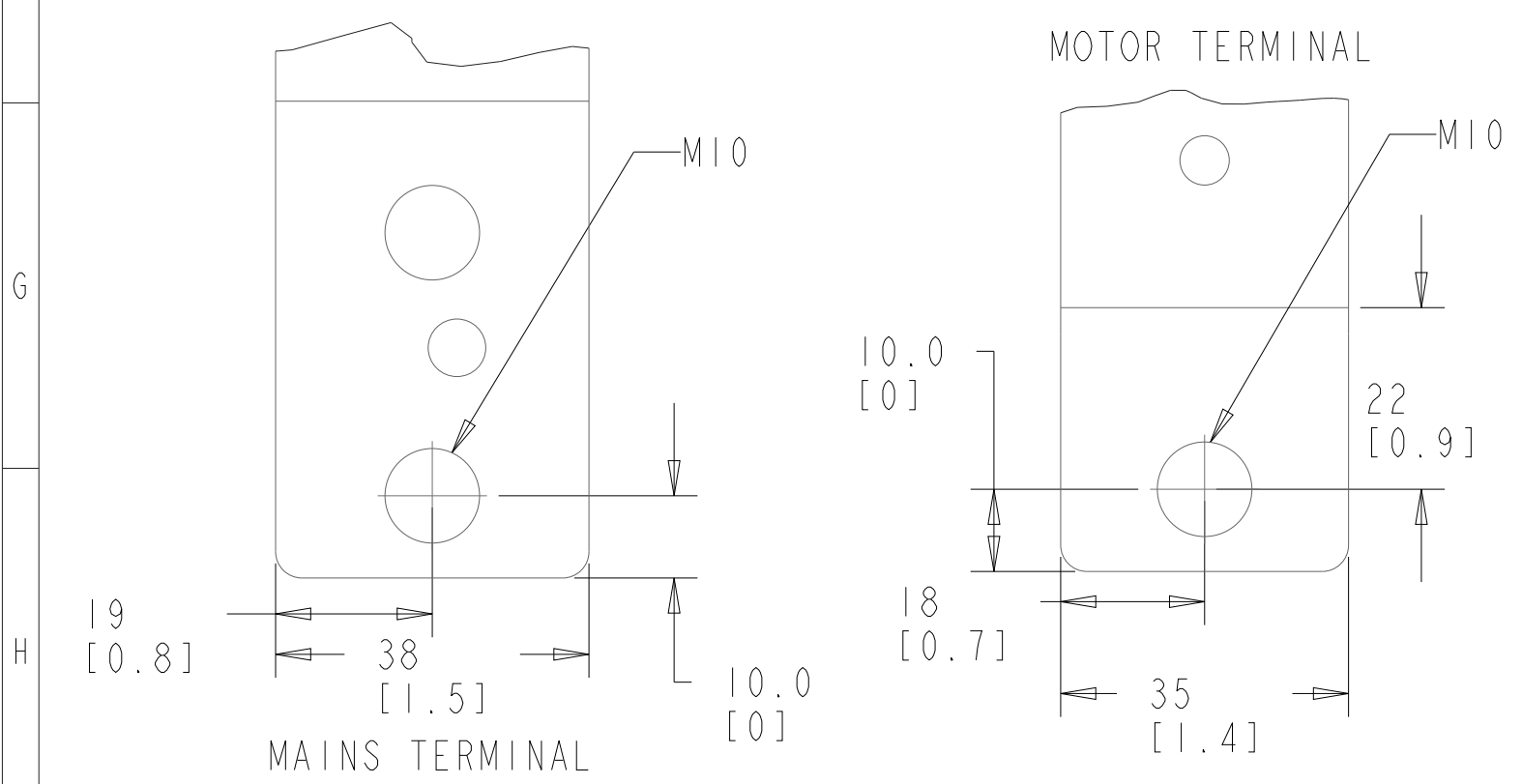
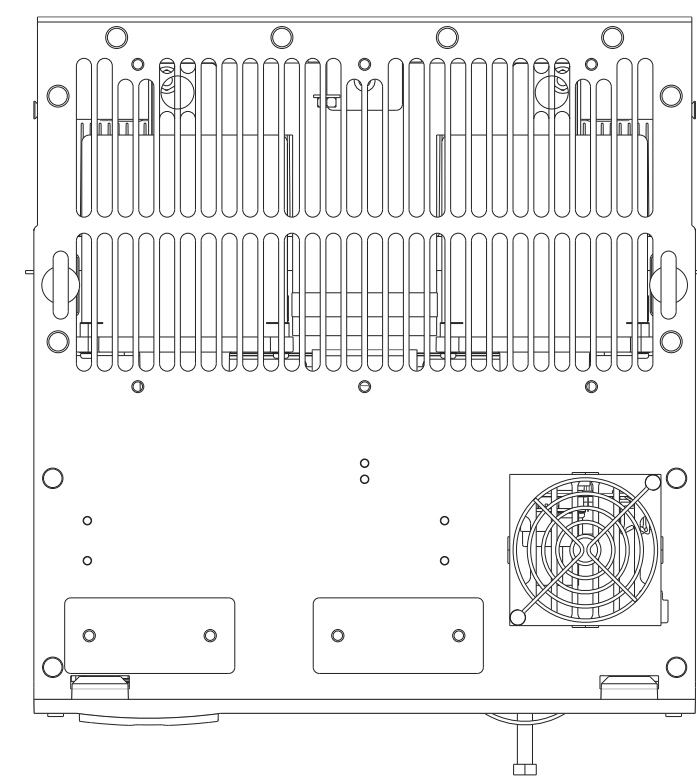

MAINS TERMINAL

MOTOR TERMINAL

NOTES:

1. PLACE CABLES THROUGH MARKED AREAS
2. 185MM² (400MCM) MAX WIRE SIZE

DRAWING NUMBER	177R0695	REV	001
MODEL	P454_D2_PRODUCTION	SHEET	2 OF 3

THE TABLES BELOW MAY BE USED TO CONFIRM THE CORRECT FRAME SIZE AND DRAWING FOR A SPECIFIC DRIVE RATING (POWER AND VOLTAGE). THIS DRAWING IS FOR D4H FRAMES, THE TABLES BELOW IDENTIFY WHICH DRIVES ARE REPRESENTED BY THIS DRAWING.

KW RATED DRIVES			
KW NORMAL OVERLOAD	200	250	315
400V	J9	J9	J9

THE TABLE BELOW CAN BE USED TO DETERMINE THE FRAME SIZE IF THE SPECIFIC MODEL/TYPECODE IS KNOWN.

PLATFORM	VOLTAGE	MODEL/TYPECODE	FRAME(IP20)
FC-361	T4	FC-361N200T4	J9
		FC-361N250T4	
		FC-361N315T4	

DRAWING NUMBER	177R0695	REV	001
MODEL	P454_D2_PRODUCTION	SHEET	3 OF 3