

Type	Value
Max Weight	9.7 kg / 21.4 lb
IP Class	IP55/66
Nema Class	Type 12/4X

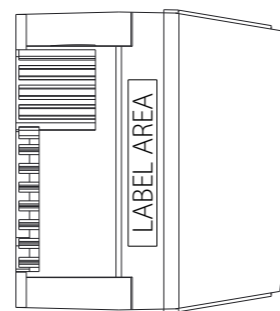
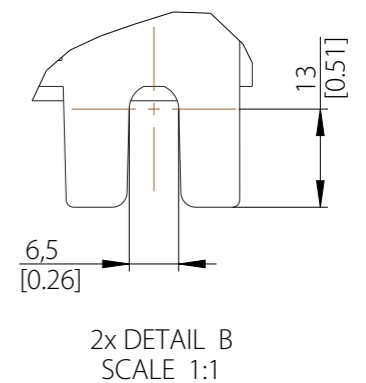
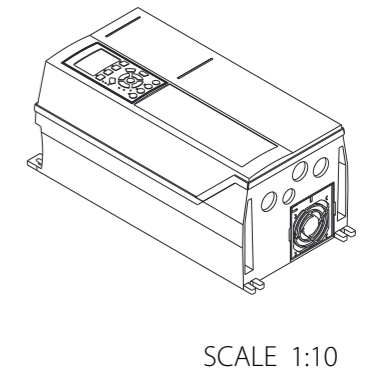
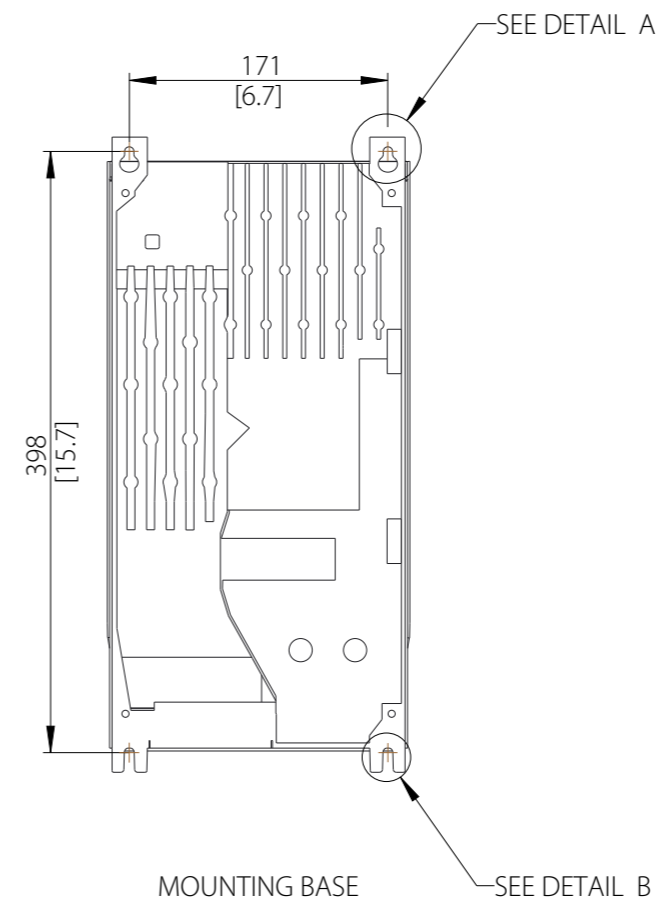
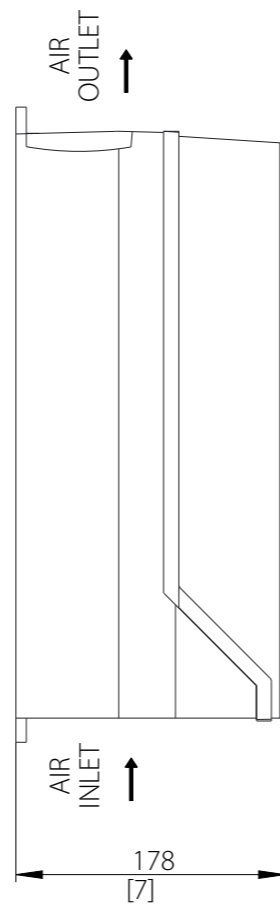
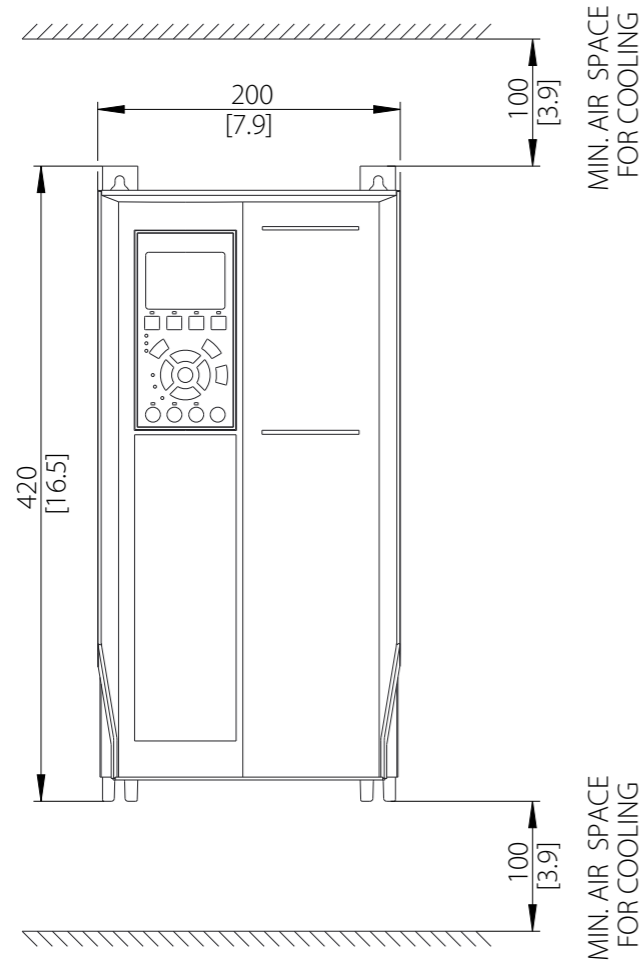
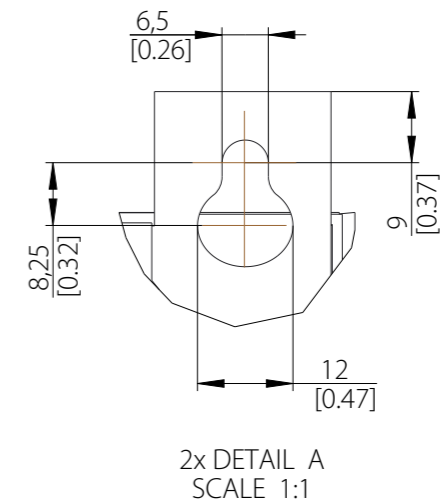
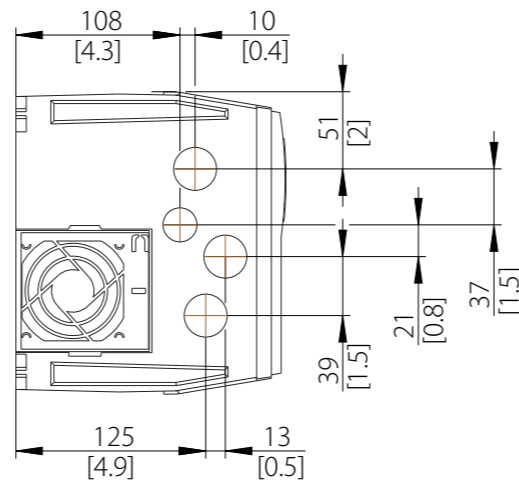

UNLESS OTHERWISE SPECIFIED THE TOLERANCE IS ± 1 MM [0.4 INCH]. ALL DIMENSIONS ARE IN MILLIMETERS [INCH]		FIRST ANGLE PROJECTION	SCALE	DRAWING SIZE	MATERIAL		
			1:5	A3	FINISH	-	
						DESCRIPTION	ENCLOSURE A4
CHANGED						DRAWING NUMBER	MCAD-FC-A4-IP55-66
DESIGNED	Danfoss					MODEL	MCAD-FC-A4-IP55-66
CHECKED	KISHORE 12-10-2020						
PROPERTY OF DANFOSS A/S NORDBORG, DENMARK. TWO OR THREE DIMENSIONAL REPRODUCTION OF CONTENTS TO BE AUTHORIZED BY DANFOSS A/S.							

THIS DRAWING SHOWS THE MOST COMMON VERSION OF THIS PRODUCT VARIANT. SMALL DIFFERENCES MAY OCCUR DEPENDING ON THE FINAL PRODUCT CONFIGURATION.

CENTER OF GRAVITY: FOR REFERENCE ONLY, THE PRODUCT CONFIGURATION MAY INFLUENCE THE CG IN ALL THREE AXES.