

SECTION A-A

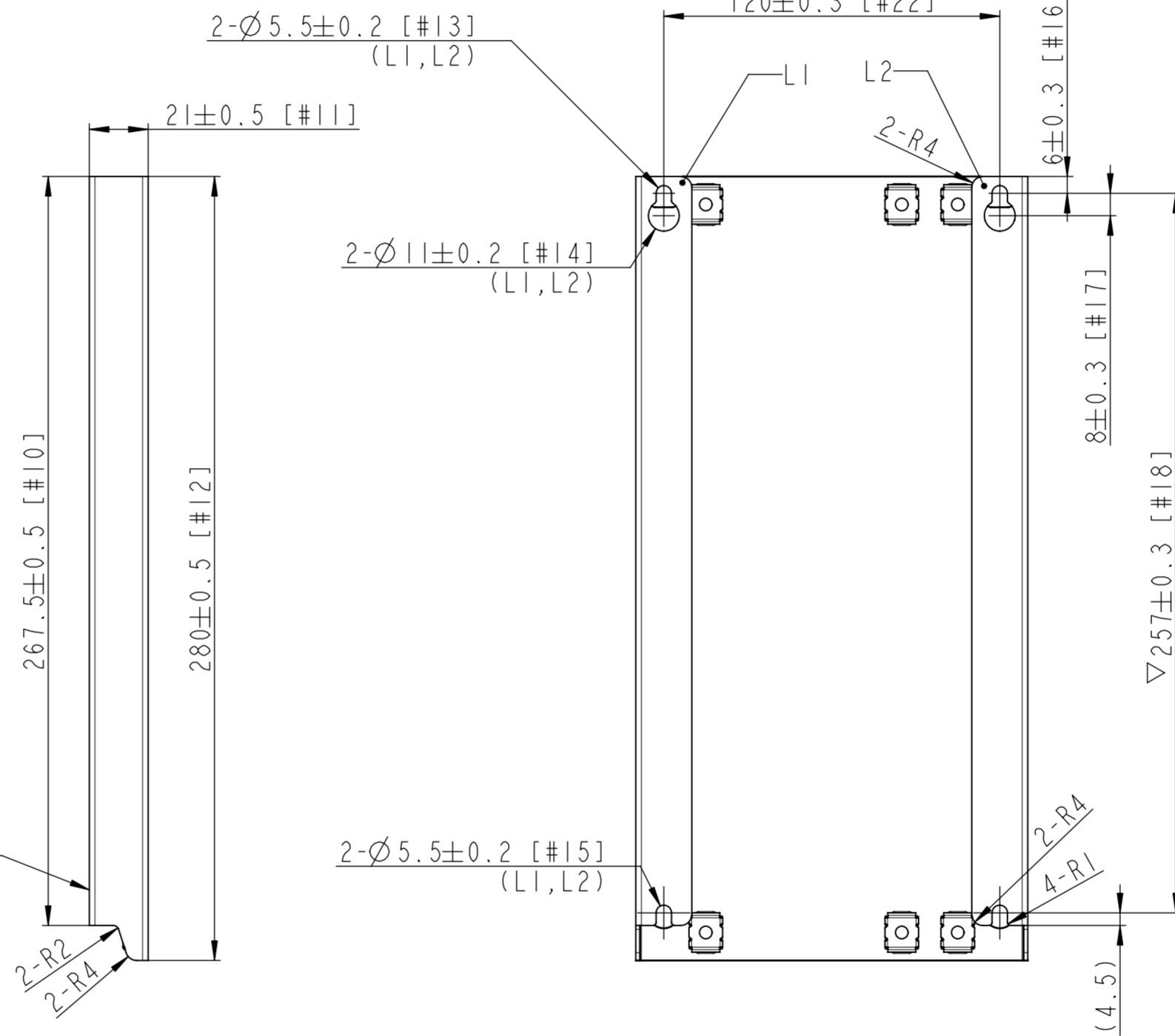
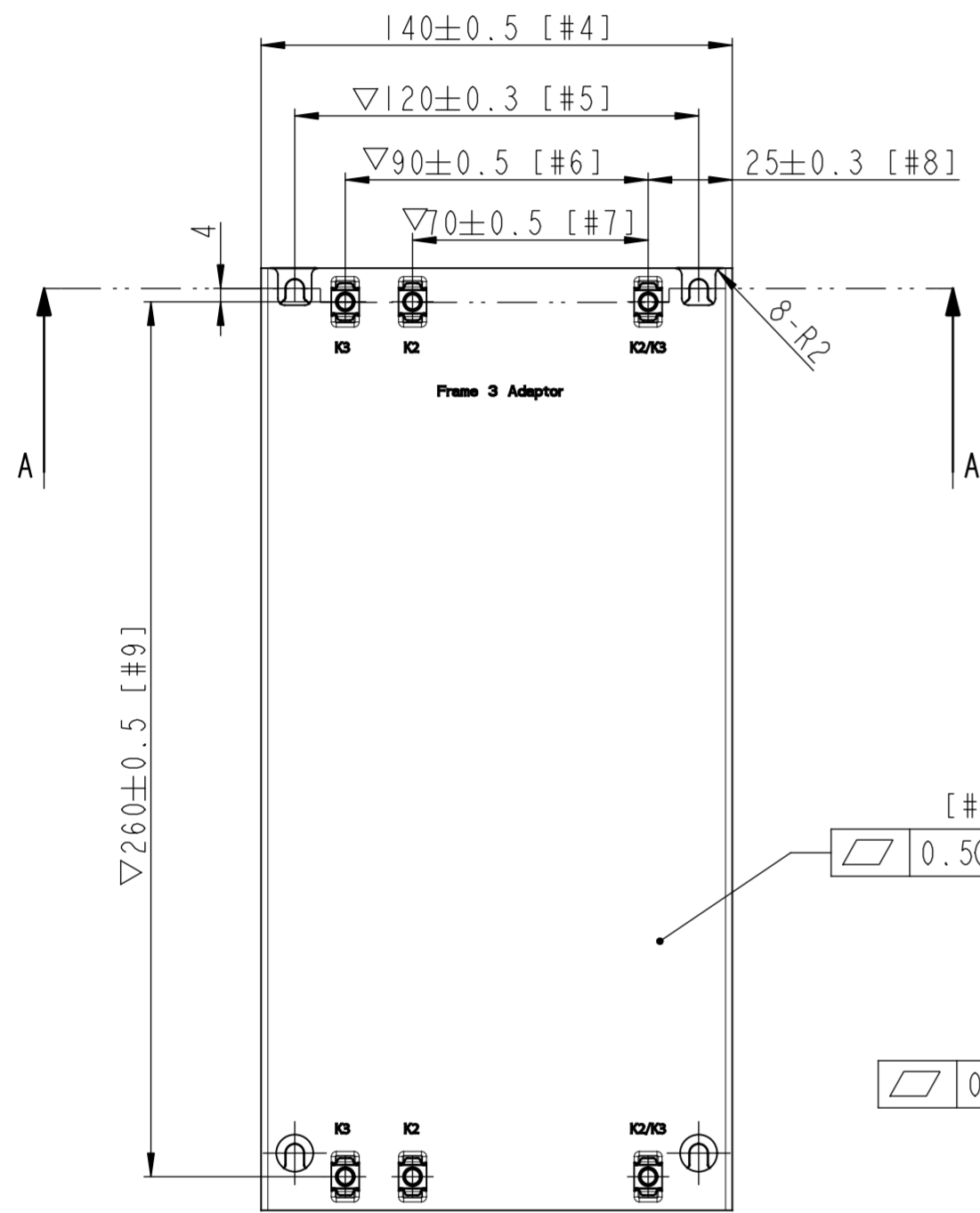

[#19] 0.5M

[#20] 0.5M

[#21] Burr side
Two sides need deburr

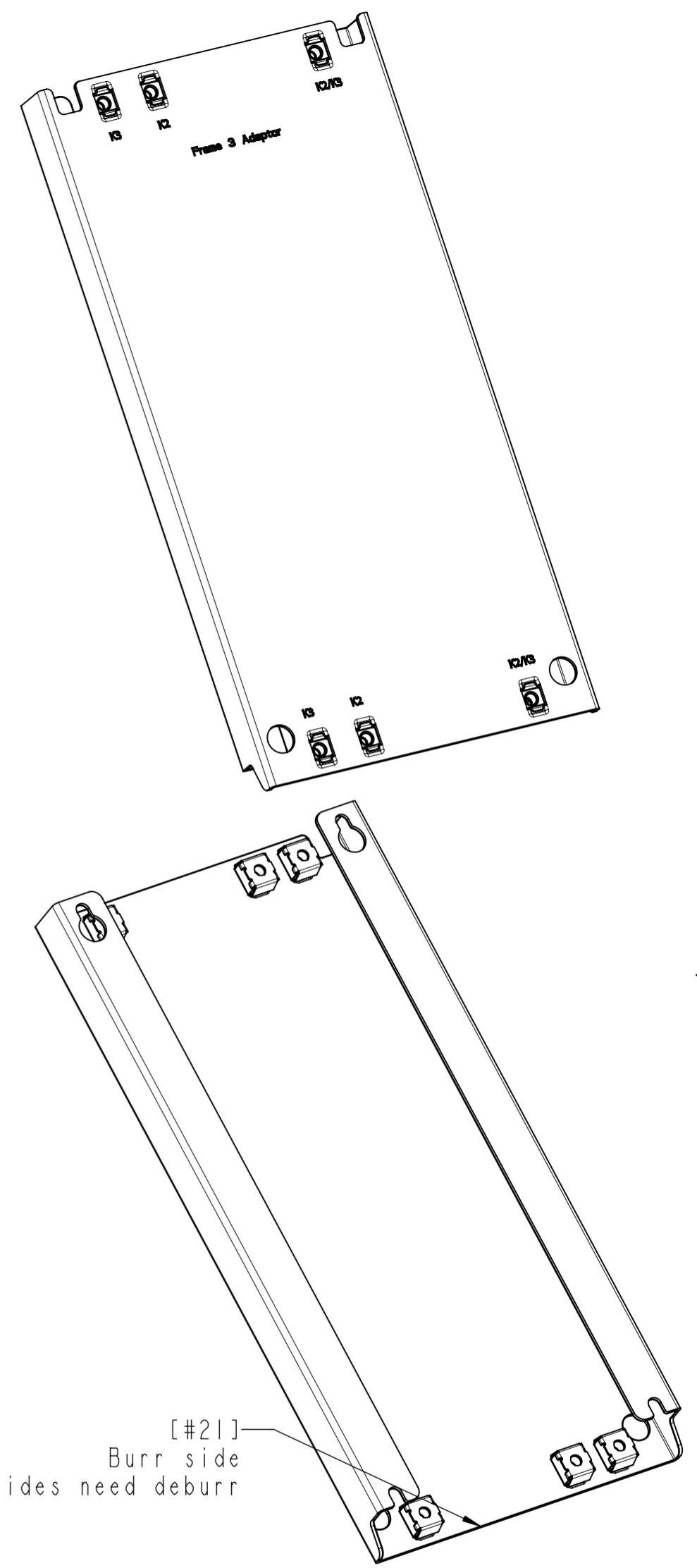

- Note:
- 1) ▽Critical Characteristic dimension no.5,6,7,9,18
 - 2) General inner bending radius : 0.5 mm
 - 3) Tolerances for not specified dimensions: ±0.25
 - 4) Corner rounds not specified: R0.5±0.2
 - 5) Part must be washed and degreased
 - 6) No impact marks acceptable
 - 7) Scratches to be avoided on visible surfaces
 - 8) Material specification:
1.5 mm Sheet acc. to EN 10346 DX51D AZ150-N-A-C
 - 9) Not specified dimensions according to unfolded part
 - 10) Part must compliance with RoHS Directive 2011/65/EU
 - 11) Sheet metal plate VOLUME = 86962MM³

No.	Item	Quantity	Description
1	Metal Plate	1	1.5 mm Sheet acc. to EN 10346 DX51D AZ150-N-A-C
2	M5 Cage Nut	6	Bossard BN3307 Article-No. - 1538284
PDM controlled drawing. Hard copy not valid without frozen date in ID Stamp		Projection	Scale 1:2
		Size A2	Material
Replace		Danfoss	
Designer Peter Peng 2015-06-25			
Designation \ Name			FC280 to VLT2800 Mounting Adaptor 3
No. 132B3774			
Rev. 001			Sheet 1 of 1

Confidential: Property of Danfoss Power Electronics A/S, Graasten, Denmark. Not to be handed over to, copied or used by third party. Two- or three dimensional reproduction of contents to be authorized by Danfoss Power Electronics A/S.

Made in: K3-ADAPTOR-ASSY-ASSEM