

additional informations:
 filter colour : impregnated
 filter weight : 600kg

label:

VL T MCC 101 sine wave FILTER
 www.dantoss.com
 Danfoss A/S, 8430 Næstved, Denmark

MADE IN GERMANY
 PN: 130B4154
 3x 525-90V- 50/60Hz (max 100Hz)
 3x 530A@50Hz 502A@60Hz 368A@100Hz
 Chassis/PSD Term. 45°C/113°F
 Power: 2400VA
 Weight: 600kg
 terminal 30mm

130B4154/00158-156

Use only with a type 1 or type 2 SPD overvoltage control device

210022
 EN 61558
 CE

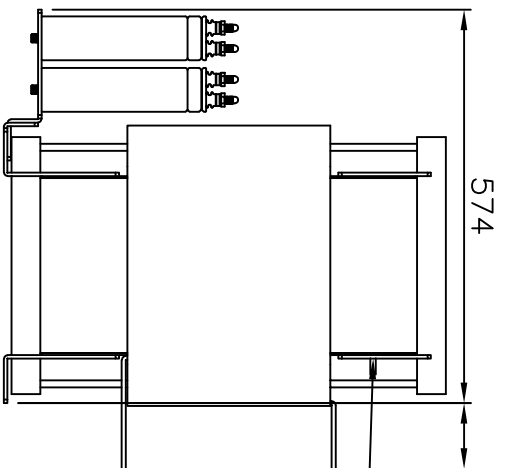
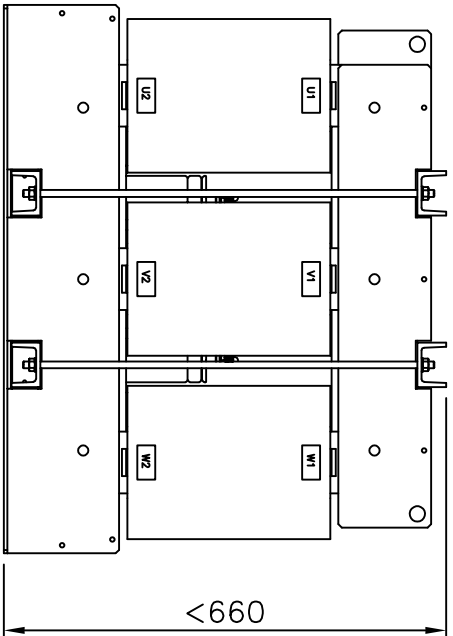

max. 110
 PE bolt M10
 (2x washer, 1 lock washer, 1 nut)

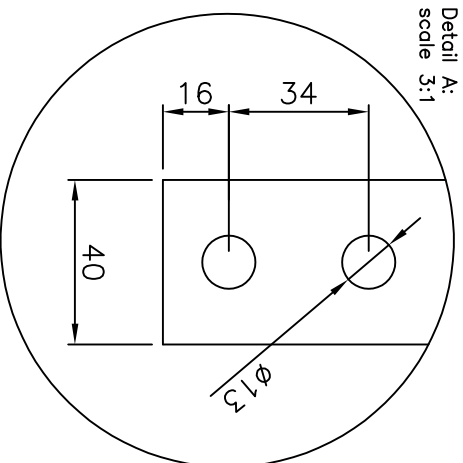
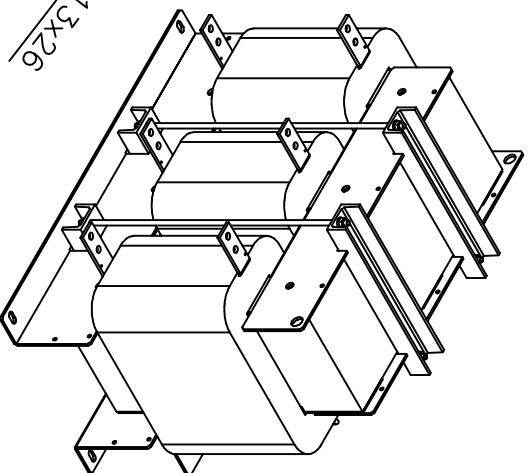
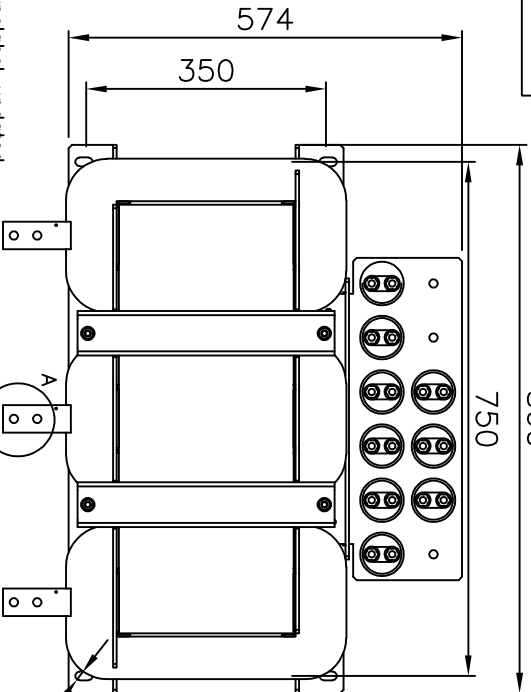

Detail A:
 scale 3:1

d	10.05.16	Schr./Fle.	typelabel updated Dantoss Postaddress included
c	22.12.14	Schr./Fle.	typelabel updated cap. connectors changed to bolt
b	25.03.13	Schr./Kor.	typelabel updated
a	01.10.10	KOR/ Lauer	approval added
	date	name	amendment

Dimensions toleranced according to ISO 2768-m			
Tolerance class	0,5	from 3	from 6
	to 3	to 6	to 30
m (middle)	±0,1	±0,1	±0,2
			±0,3
			±0,5
			±0,8

drawn	06.05.10	Kornau	Kornau	scale
checked	06.05.10	Bremer	Bremer	format
	date	name	signature	A4

Dimensions B 1002058
 sine-wave filter 690V 530A – IP00

order number	130B4154	drawing number	Z791004018	modi.	d	sheet	1/1
Please observe protection clause to ISO 16016							

1 2 3 4 5 6 7 8

F E D C B A

1 2 3 4 5 6 7 8

F E D C B A

1 2 3 4 5 6 7 8

F E D C B A

1 2 3 4 5 6 7 8

F E D C B A

1 2 3 4 5 6 7 8

F E D C B A

1 2 3 4 5 6 7 8

F E D C B A

1 2 3 4 5 6 7 8

F E D C B A

1 2 3 4 5 6 7 8

F E D C B A

1 2 3 4 5 6 7 8